

# Finding Faults Fast Saves Money and Improves Service

Artur Hoff, *Terna Plus*

Ricardo Abboud, Renan Bernardes, and Paulo Lima, *Schweitzer Engineering Laboratories, Inc.*

**Abstract**—This paper discusses the concepts, design, benefits, and deployment of a traveling-wave fault locating (TWFL) system for a 500/230 kV transmission system in Brazil with line lengths ranging from 158 to 355 km (98 to 221 mi). The system uses existing communications infrastructure to send accurate fault location in real time to the control center without any human intervention. The system is also capable of line monitoring, providing an important tool to line maintenance personnel. The line monitoring function detects weak spots along the line, such as dirty or cracked insulators, incipient cable faults, encroaching vegetation, marginal clearance, or marginal lightning protection. This feature is used to prevent line faults and allow conditions-based line maintenance. The paper also discusses the concepts of different fault-locating methods.

## I. INTRODUCTION

Energy market deregulation in different parts of the world has changed the way transmission grid companies (TGCs) manage and operate their assets, imposing more strict and rigorous performance requirements. In such deregulated markets, like the Brazilian market, the earnings of TGCs are based on the amount of time the assets are made available to carry power over the bulk transmission system, not based on the amount of energy that is actually transmitted; in the case of a transmission line, earnings are related to the amount of time that the line is in-service. Heavy financial penalties are applied when the transmission line is unexpectedly taken out of service, such as due to a sustained fault. The entire monthly revenue for a transmission line can be totally consumed by the penalty toll in a matter of hours if the fault is not located and the problem fixed quickly. The time required to bring the line in-service again is often spent locating the fault point, making the accuracy of a fault-locating system of utmost importance to reduce the line restoration time and avoid penalties.

Single-ended impedance-based fault locating is a common method used to help maintenance crews find faults on transmission lines, but it is susceptible to inaccuracies.

The capabilities of modern microprocessor-based relays have made it possible to sample voltage and current signals at the rate (around 1 MHz) required to capture traveling-wave (TW) information. This new technology is the base for ultra-high-speed (UHS) protection elements, highly accurate traveling-wave fault locating (TWFL), and high-resolution oscillography in protective relays. Relays also store oscillographic records, allowing the analysis of fast transient

phenomena in the power system; these records are now available for any transmission line protected with TW-capable relays.

TWFL is highly accurate. It can locate the fault with an accuracy better than one tower span regardless of the line length, and can therefore provide extremely precise information on the location of the fault. When used correctly, TWFL drastically reduces the cost of identifying the location needing repair, as compared to the cost of traditional methods. Therefore, the installation of a TWFL system is generally less expensive than the economic loss it saves in only its first use.

Vegetation growing under the line is one important potential cause of permanent faults. However, in many cases the first faults caused by vegetation are temporary, so an accurate TWFL system can pinpoint locations with repetitive temporary faults before they become permanent faults, allowing personnel the opportunity to properly trim vegetation in a timely manner. As a result, the TWFL system helps prevent the occurrence of permanent faults that cause service interruptions, which reduces penalties and increases the transmission system reliability.

## II. FAULT LOCATING FUNDAMENTALS

There are several fault-locating methods applicable to transmission lines and they can be divided into two main categories—impedance-based methods and TW-based methods. Both types of methods have advantages and their own challenges; therefore, applying them together in the same device allows them to complement each other. The following sections provide a brief description of some commonly applied methods.

### A. Impedance-Based Methods

#### 1) Single-Ended Impedance-Based Fault Locating (SEZFL)

The SEZFL method uses voltages and currents measured at a single end of the transmission line, extracts their fundamental-frequency components using a digital filter, calculates their phasor values, determines the fault type, and finally applies an impedance-based equation to the fault-loop phasors to produce a fault location estimation. This method is available in the vast majority of transmission line protective relays [1] [2].

Fig. 1 depicts a simple two-source system where a fault occurs at a distance  $m$  (in per unit of line length) from Bus S. The SEZFL method calculates the fault location  $m$  using (1).

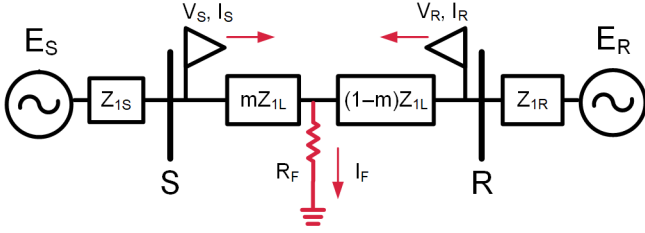

Fig. 1. Two-source example system.

$$m = \frac{\text{Im}(V_S \cdot [I_P]^* \cdot e^{-jT})}{\text{Im}(Z_{1L} \cdot I_S \cdot [I_P]^* \cdot e^{-jT})} \quad (1)$$

where:

$m$  is the distance to the fault from Bus S in per unit of line length.

$V_S$  is the measured voltage at Terminal S for the selected fault loop.

$I_S$  is the measured current at Terminal S for the selected fault loop.

$I_P$  is the polarizing current selected according to the fault type.

$Z_{1L}$  is the positive-sequence line impedance.

$T$  is the nonhomogeneity correction factor.

The SEZFL method determines the fault loop and selects the voltages and currents to be applied in (1) according to Table I.

TABLE I  
FAULT LOOP VOLTAGES AND CURRENTS FOR SEZFL

Loop	$V_S$	$I_S$	$I_P^\dagger$
AG	$V_A$	$(I_a + 3 \cdot k_0 \cdot I_0)$	$I_2$
BG	$V_B$	$(I_b + 3 \cdot k_0 \cdot I_0)$	$I_2$
CG	$V_C$	$(I_c + 3 \cdot k_0 \cdot I_0)$	$I_2$
AB or ABG	$V_{AB}$	$I_{AB}$	$I_2$
BC or BCG	$V_{BC}$	$I_{BC}$	$I_2$
CA or CAG	$V_{CA}$	$I_{CA}$	$I_2$
ABC	$V_{AB}$ or $V_{BC}$ or $V_{CA}$	$I_{AB}$ or $I_{BC}$ or $I_{CA}$	$I_1$

<sup>†</sup> Other options exist; the table shows the best option.

The zero-sequence compensation factor  $k_0$  is calculated using (2).

$$k_0 = \frac{(Z_{0L} - Z_{1L})}{3Z_{1L}} \quad (2)$$

where:

$Z_{1L}$  is the positive-sequence line impedance.

$Z_{0L}$  is the zero-sequence line impedance.

The fault  $M$  in kilometers or miles can be found by multiplying  $m$  by the total line length (LL), given in kilometers or miles, as shown in (3).

$$M = m \cdot LL \quad (3)$$

The SEZFL method has been used for decades in microprocessor-based relays with relatively good field results. The accuracy and sensitivity of the method can be assessed using (1) and results from fault calculations. The advantage of this method is that it does not require communication and time synchronization. However, the method accuracy is affected by fault resistance combined with line loading, infeed effect, zero-sequence mutual coupling, transmission line asymmetry, capacitively-coupled voltage transformer (CCVT) transients, and current transformer (CT) saturation. Even with the use of a nonhomogeneity correction factor and zero-sequence current polarization for single-phase-to-ground (SLG) faults, this method may not produce optimum results. The performance of this method is highly dependent on the accuracy of the values of the positive- ( $Z_{1L}$ ) and zero-sequence ( $Z_{0L}$ ) line impedances. The method is not applicable to series-compensated lines or hybrid lines (composed of overhead and cable sections).

## 2) Double-Ended Impedance-Based Fault Locating (DEZFL)

The DEZFL method uses voltages and currents measured at both ends of the transmission line and requires a communications channel to implement the real-time DEZFL function in protective relays. The method also requires time alignment of the data measured at both terminals. If a communications channel is not available, the method can be applied offline using manual or automated calculations.

The DEZFL method is based on the negative-sequence voltage profile along the faulted line for unbalanced faults and the positive-sequence voltage profile for balanced faults. Fig. 2 shows the voltage profiles for phase and single-phase-to-ground faults.

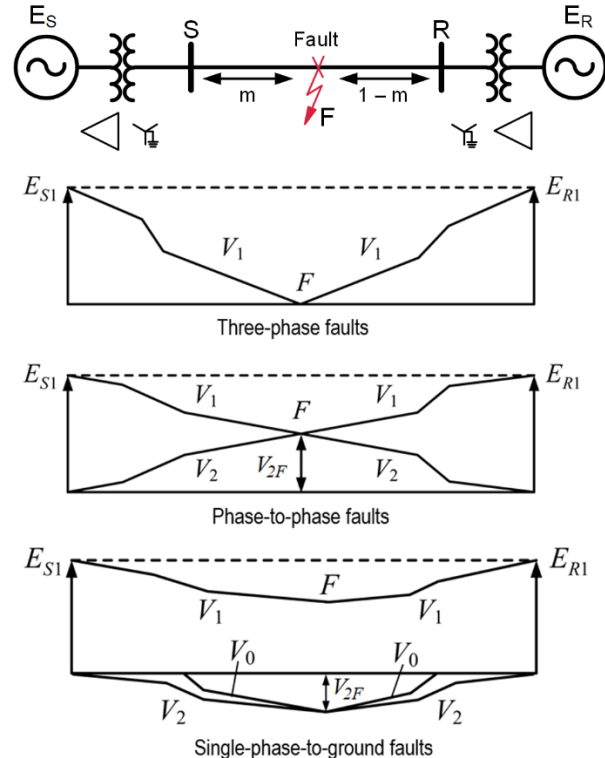

Fig. 2. Voltage profiles along the faulted line.

We can apply Kirchhoff's voltage law in the equivalent system shown in Fig. 2 when voltages and currents are available from both terminals, as shown in (4) and (5) [3] [4].

$$V_F = V_S - mZ_{IL} \cdot I_S \quad (4)$$

$$V_F = V_R - (1-m)Z_{IL} \cdot I_R \quad (5)$$

where:

$V_S$  is the measured voltage at Terminal S (negative-sequence voltage for unbalanced faults and positive-sequence voltage for balanced faults).

$I_S$  is the measured current at Terminal S (negative-sequence current for unbalanced faults and positive-sequence current for balanced faults).

$V_R$  is the measured voltage at Terminal R (negative-sequence voltage for unbalanced faults and positive-sequence voltage for balanced faults).

$I_R$  is the measured current at Terminal R (negative-sequence current for unbalanced faults and positive-sequence current for balanced faults).

$V_F$  is the voltage at the fault location (negative-sequence voltage for unbalanced faults and positive-sequence voltage for balanced faults).

Solving (4) and (5) for  $m$  we obtain (6):

$$m = \frac{V_S - V_R + Z_{IL} \cdot I_S}{(I_S + I_R) \cdot Z_{IL}} \quad (6)$$

When a direct communications channel between the devices installed at Terminals S and R is available, the DEZFL method can be used for real-time fault locating. If a channel is not available, we can obtain voltage and current information from the relay reports and perform an offline calculation using (6).

The DEZFL method is not affected by fault resistance, line loading, system nonhomogeneity, or zero-sequence mutual coupling, which improves the accuracy compared to the SEZFL method [4]. The method is easy to implement in line current differential relays and does not require external time-based synchronization when applied with high-bandwidth and symmetrical communication channels (such as a direct relay-to-relay fiber-optic connection).

Nontransposed lines affect the accuracy of this method, but less than they affect the SEZFL method. The performance of the DEZFL method may be hardly affected by CCVT transients and CT saturation due to the exponentially decaying component, especially when applied to line terminals that have UHS protection and two-cycle interruption circuit breakers.

As with SEZFL, the DEZFL accuracy depends on the accuracy of parameter  $Z_{IL}$ , but it does not depend on  $Z_{0L}$ .

Both impedance-based methods have limitations for applications in series-compensated lines. Additionally, the reduction in fault-clearing time provided by modern relays reduces the information available for impedance-based fault-locating methods and affects their performance. In order to have a reliable calculation, the phasors should be estimated after the transients in the measured signals disappear and before the transients created by the circuit breaker opening appear. With the short fault duration in extra-high voltage (EHV) and ultra-high voltage (UHV) systems (approximately two cycles when

UHS protection is applied), there is practically no time for the measured signals to stabilize [5].

## B. Traveling-Wave-Based Methods

### 1) Double-Ended Traveling-Wave-Based Fault Locating (DETWFL)

DETWFL uses the arrival times of the first TWs at both line ends to locate the fault.

Fig. 3 shows a fault occurring on a transmission line at a per-unit distance  $m$  from Terminal S. The fault launches two waves that travel from the fault location toward Terminals S and R. In overhead lines, the TW velocity is close to the speed of light.

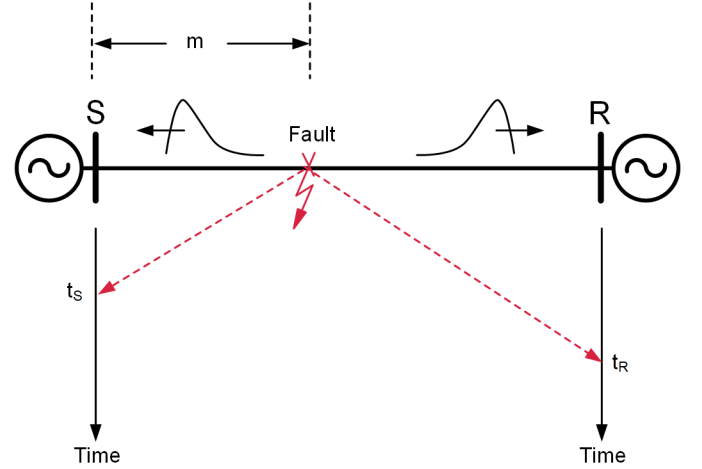

Fig. 3. The fault launches TWs that travel towards the line ends.

Fig. 3 also shows the Bewley diagram representing the TWs on a distance-time plane [6]. The arrival times of the first TWs at Terminals S and R are  $t_s$  and  $t_r$  respectively. Assuming the fault to be closer to Terminal S,  $t_s < t_r$ . For this case, the DETWFL method uses (7) to locate the fault [6].

$$m = \frac{LL}{2} \left[ 1 + \frac{t_s - t_r}{\text{TWLPT}} \right] \quad (7)$$

where:

$m$  is the distance to the fault location from S in per unit.

$LL$  is the total line length.

$t_s$  is the TW arrival time at Terminal S.

$t_r$  is the TW arrival time at Terminal R.

TWLPT is the one-way end-to-end TW propagation time on the transmission line.

The TW propagation time (TWLPT) can be measured during commissioning by performing a line energization test.

The DETWFL method acquires and filters the input current signals, extracts and processes the TW signals, and time-stamps the TW arrival instant with microsecond accuracy or better. The relay at each line terminal sends the time-stamped arrival time information to the relay at the other line terminal. References [6] and [7] discuss the requirements to perform these tasks reliably.

Because the frequency response of CTs is better than that of CCVTs or inductive voltage transformers (VTs), it is preferable to use currents for TWFL.

The DETWFL method, like the two impedance-based methods discussed previously, can be implemented in a standalone fault locator or can be incorporated in a microprocessor-based protective relay.

For real-time fault locating, the method requires a communications channel connecting the protective relays at both line ends, which can be the same channel used for the line current differential scheme or it can be a dedicated communications port for DETWFL data exchange. Fig. 4 shows an example using a multiplexed communications channel, where each protective relay connects to the multiplexer through an IEEE C37.94 communication card. In such applications, an external time source, like a Global Navigation Satellite System (GNSS) clock, is required to time-stamp the measured TWs with the required accuracy; then the resulting  $t_s$  and  $t_r$  values are exchanged between the two relays in real time, and used in (7) to calculate  $m$ .

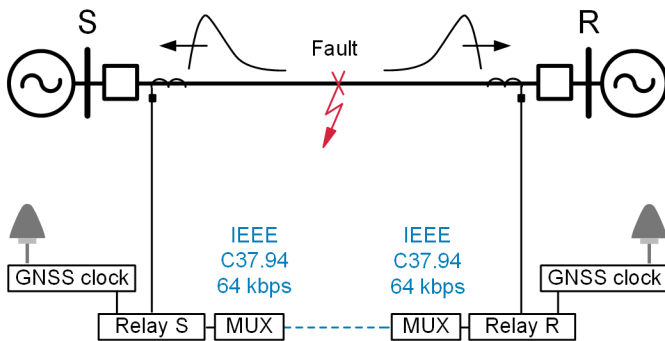

Fig. 4. DETWFL implementation with a multiplexed communications channel.

For applications where a dedicated optical fiber is available to directly connect the relays, as shown in Fig. 5, a GNSS clock is not required for DETWFL. The time synchronization can be performed through the direct communications channel. The elimination of the additional external time synchronization naturally makes the system more reliable and robust.

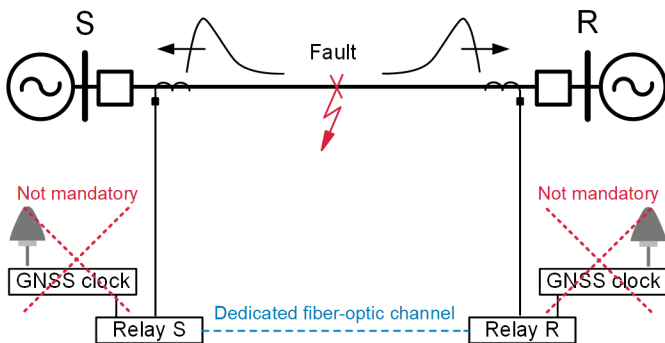

Fig. 5. DETWFL implementation with a direct fiber-optic communications channel.

Fault location information from the DETWFL method can be sent in real time to a control center using the substation automation infrastructure, as shown in Fig. 6. Different protocol options are available, such as DNP3, IEC 61850, Modbus, IEC 60870-5-101, IEC 60870-5-104, and more. It is not necessary to install any additional software or device in the

control center for offline calculations. A failure in the communication from one of the substations to the control center does not defeat the DETWFL method because the fault location information can be sent by the relay installed in the other substation.

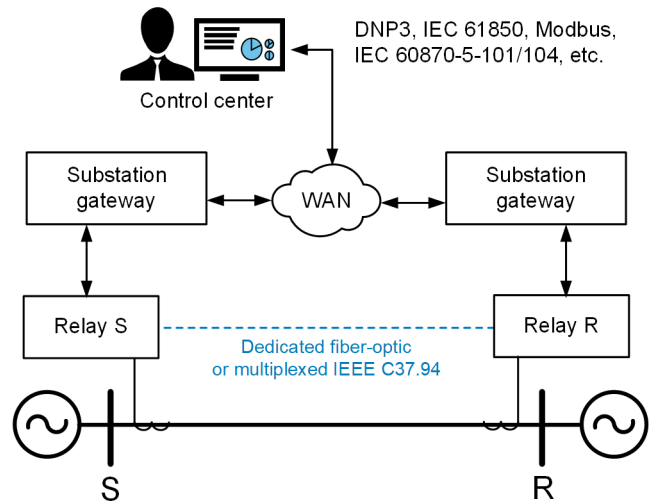

Fig. 6. Relays with DETWFL function can send fault location information directly to a control center using different protocols.

In applications where a communications channel between relays is not available, it is possible to collect the TW arrival time from both relays through remote communication and perform an offline calculation using (7) [8].

Field results have shown that the DETWFL fault-locating method can achieve accuracy of 300 m (1,000 ft) on average, or about one tower span, for lines of any length [9].

In applications where the CT secondary cables have considerable differences in length, causing significant TW propagation time differences at the line terminals, the accuracy of the DETWFL method can be affected. Assuming the TW propagation velocity for cables to be 70 percent of the speed of light in free space, 50 m of difference in cable length between line terminals may result in 36 m of fault location error for the DETWFL method in an overhead line [9].

The DETWFL method can compensate for the CT cable delay between the CTs and the relay by modifying (7) to include the CT cable propagation delay, as shown in (8).

$$m = \frac{LL}{2} \left[ 1 + \frac{(t_s - TWCT_S) - (t_r - TWCT_R)}{TWLPT} \right] \quad (8)$$

where:

$m$  is the distance to the fault location from terminal S in per unit of line length.

$LL$  is the total line length.

$t_s$  is the TW arrival time at Terminal S.

$t_r$  is the TW arrival time at Terminal R.

$TWCT_S$  is the TW propagation time in the CT cables at Terminal S.

$TWCT_R$  is the TW propagation time in the CT cables at Terminal R.

TWLPT is the one-way end-to-end TW propagation time on the transmission line.

The DETWFL method overcomes the following limitations of the impedance-based fault-locating methods:

- Accuracy does not depend on  $Z_{1L}$  and  $Z_{0L}$  impedances.
- The method is applicable on lines with series compensation.
- The method is not affected by fault resistance, line loading, zero-sequence mutual coupling, infeed, or system nonhomogeneity.
- The method is applicable on hybrid lines when the proper compensation is implemented.
- With the improved accuracy provided by this method, the fault location value can be used to inhibit circuit breaker autoreclosing in real-time, depending on the fault location. This is a good solution to implement adaptive autoreclosing for hybrid lines, allowing autoreclosing for faults in overhead sections and blocking for faults in cable sections.

## 2) Single-Ended Traveling-Wave-Based Fault Locating (SETWFL)

The SETWFL method uses the time difference between the arrival of the first TW coming directly from the fault and the arrival of the first TW reflected from the fault to estimate the fault location [10].

Fig. 7 shows the Bewley diagram for a fault on a transmission line. The fault is at a per-unit distance  $m$  from Terminal S and at a distance  $1 - m$  from Terminal R. A current TW launched at the fault location arrives at Terminal S at time  $t_{S1}$ . Part of the wave reflects, travels back toward the fault, reflects back from the fault, and then arrives at Terminal S at time  $t_{S3}$ . During the  $(t_{S3} - t_{S1})$  time interval, the TW traveled a distance of  $2 \cdot m$ .

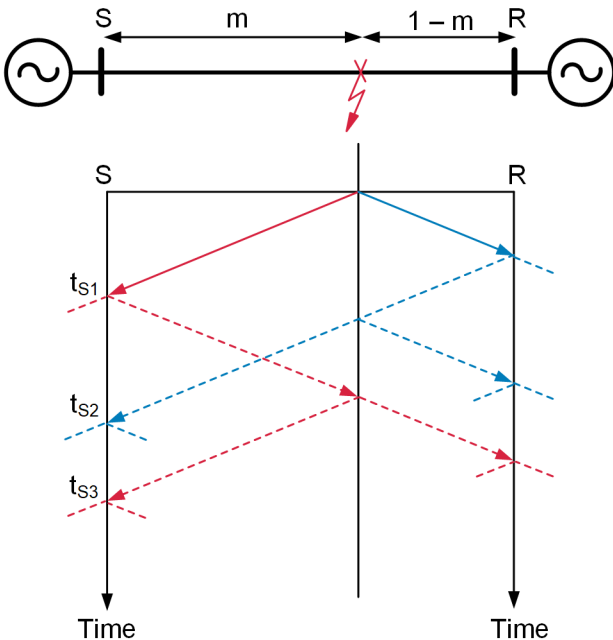

Fig. 7. Bewley diagram explaining the SETWFL method.

As previously mentioned, the transmission line propagation time TWLPT is a known parameter, which is measured during commissioning by performing a line energization test. The method uses (10) to calculate  $m$  [10].

$$2 \cdot m = (t_{S1} - t_{S3}) \cdot \frac{LL}{TWLPT} \quad (9)$$

$$m = \frac{(t_{S1} - t_{S3}) \cdot LL}{2 \cdot TWLPT} \quad (10)$$

The SETWFL method works well if it correctly identifies the arrival time of the first TW returning from the fault (time  $t_{S3}$ ). If instead the SETWFL method uses the arrival time of some other wave reflection as the first return from the fault, the fault location estimation result would be entirely incorrect. Referring to Fig. 7, the first TW that arrives at Terminal R reflects from the bus, returns to Terminal S, refracts through the fault point, and arrives at Terminal S at time  $t_{S2}$ . If the SETWFL method uses  $t_{S2}$  as the arrival time of the first TW returning from the fault, the fault location result will be incorrect. Reference [10] discusses innovative ways to implement the SETWFL method and how to correctly identify reflections from the fault point.

The SETWFL method uses only local time stamps and is therefore immune to errors and tolerances in time alignment between the local and remote relays. Consequently, this method can be even more accurate than the DETWFL method if the first reflection from the fault can be found properly. The method is not affected by failures in the global time synchronization system, making it a natural backup scheme for methods that require such time synchronization.

## III. LINE MONITORING FUNCTION

Most faults in electric power systems occur in overhead transmission lines. By using air as an insulator and extending for tens or hundreds of kilometers, overhead lines are exposed to conditions that eventually cause faults. Some causes of line faults develop over days, weeks, or even months, including encroaching vegetation, contamination of insulators by chemicals and bird waste, and aging. With the gradual degradation of insulation, a transmission line can experience fault precursors—events that are not permanent faults, but low-energy events that last for less than a millisecond, causing only transients in the network. Conventional line protection relays do not include any dedicated function to detect, record, or respond to these fault precursors [11]. Relays that support the DETWFL and high-accuracy fault recording now make it possible to create functions to track these precursors and take appropriate action.

Fig. 8 shows a fault precursor captured in a high-resolution oscillographic record (1 MHz sampling rate) five cycles before the insulation breakdown that caused a fault in the transmission line. Normally, the fault precursors do not happen right before the actual fault; they can appear days, weeks, or months before, as already stated. The plot TWIA\_ALPHA shows the output signal of the filter that extracts the TW alpha component from the phase currents [6].

Once a fault precursor current reaches a level of a few tens of primary amperes, it can be detected at the line terminals by the DETWFL function. However, the fault precursor is not classified as a fault but is instead classified as an event since there is no protection element trip. The DETWFL function can report the location of the fault precursor event accurately; the DETWFL only needs to detect and time-stamp the first waves caused by the event at both ends of the line.

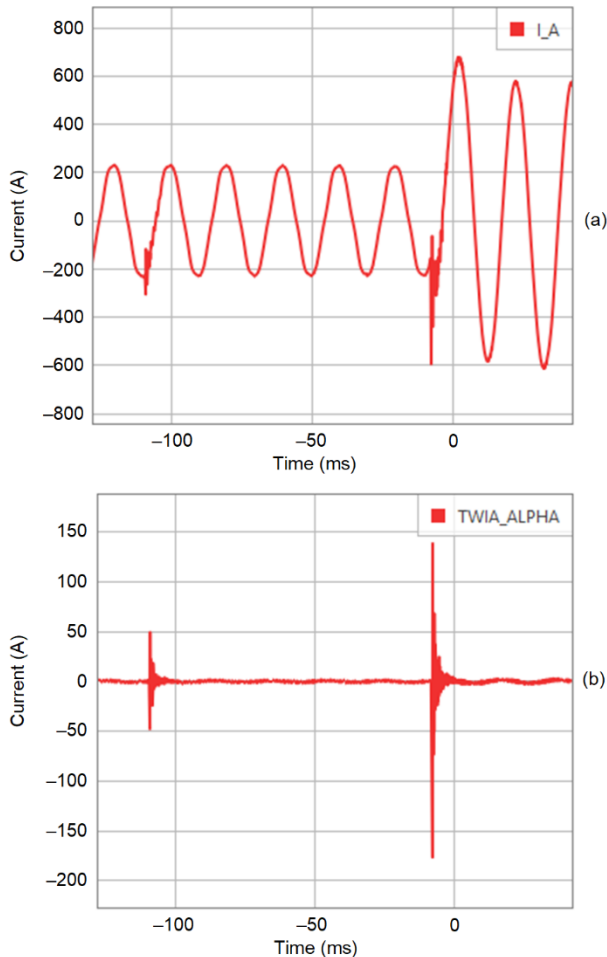

Fig. 8. High-resolution oscillography showing (a) the fault precursor in the raw current signal and (b) the correspondent TW alpha component extracted from the raw current signal.

Some of the causes of fault precursors are the following [11]:

- Bird waste contamination of insulators
- Chemical/pollution contamination of insulators
- Vegetation growing under the transmission line
- Fire in the line right-of-way
- Insulator aging and hidden failures

Monitoring the fault precursors allows users to predict a certain number of faults in transmission lines. Line maintenance crews can take actions before a fault occurs and causes the transmission line to open unexpectedly with possible severe consequences to the power system. This monitoring function is especially important in energy markets where TGCs are penalized by unexpected transmission line outages with duration greater than a certain time.

The line-monitoring function (LIMO) splits the transmission line into  $n$  sections, with each section representing a bin (see Fig. 9). Each bin has a counter that accumulates the number of events located within that bin. When an event is detected, the DETWFL function determines the event location, and the LIMO function increments the counter associated with the bin where the event is located. The LIMO function issues an alarm when the counter reaches a settable threshold.

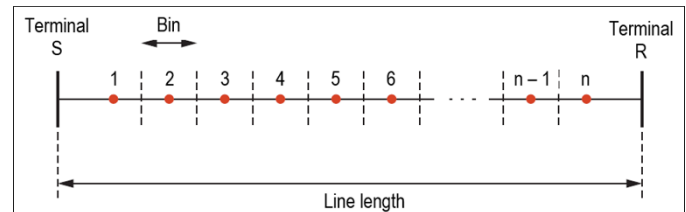

Fig. 9. The LIMO function divides the line into bins and counts the number of fault events located in each bin.

Reference [11] describes a LIMO available in commercial line protection relays. The LIMO uses the DETWFL function and has the following main features:

- The LIMO is triggered by the current TWs generated by fault precursors (with or without protection operation)
- The DETWFL function locates events with high accuracy using data from two terminals
- The LIMO sorts events for locations along the line and increments the counter associated with the bin corresponding to the specific section of the line
- The LIMO issues an alarm if the event counter of any bin along the line exceeds the limit set by the user

When the LIMO issues an alarm indicating a transmission line location is experiencing a high number of fault precursors, the TGC can take the following actions before a transmission line trip occurs:

- Dispatch the line maintenance crew to the location indicated by the LIMO
- Find and correct the problem by cleaning dirty insulators, trimming vegetation, installing dampers or spacers in the line, etc.
- Reset the event counter of the bin that triggered the alarm after proper maintenance has been performed

#### IV. TRANSMISSION SERVICE QUALITY REGULATION IN BRAZIL

In some countries, the earnings of TGCs are based on the energy transported through transmission lines and other assets. In this scenario, the power that has flowed through the transmission installations is determined periodically to calculate the total amount of money to be received by the TGC as revenue.

This form of earnings for transmission services induces TGCs to operate the transmission system at maximum capacity and to reduce equipment unavailability as much as possible. If the TGCs fail to achieve these goals, their revenues drop.

In Brazil, the earnings received by the TGCs for transmission services is not based on the energy transported through transmission assets. The revenue is defined when the

TGC is granted a concession agreement contract to provide a certain transmission service and asset. This revenue is associated with the availability of equipment for use in the national transmission system by the independent system operator (ISO). The concession agreement contract defines an annual revenue (AR) received by the TGC for the assets included in the contract. The AR is received by the TGC in a year if the assets are made available to the ISO; however, in the case of asset unavailability greater than one minute, a monetary penalty is applied, with a consequent earnings reduction, as explained later in this section.

The Brazilian TGCs receive a monthly revenue (MR) for each transmission line they own, corresponding to one twelfth (1/12) of the agreed AR as defined in the concession contract. A value called variable portion (VP), calculated based on the unavailability of each transmission line, can be deducted from this monthly revenue. Thus, the contract the TGCs sign with the Brazilian Regulatory Agency (Agência Nacional de Energia Elétrica [ANEEL]), defines the conditions for calculating the monthly revenue, as well as the discount calculations due to asset unavailability.

The VP penalty is composed of three parts, (1) penalty due to energization delays, (2) penalty due to operative restrictions, including power capacity reduction of the asset, and (3) penalty due to asset outages. There are scheduled outages for reasons such as maintenance activities or equipment replacement, and there are unexpected outages, such as those caused by sustained transmission line faults. There is a deductible amount of time allowed for scheduled maintenance, and the penalty is applied only if the outage exceeds that time.

The VP was created in order to improve the quality of the transmission service provided by Brazilian TGCs that own assets connected to the national bulk electric power system. The purpose of the penalties is to encourage the TGCs to improve the performance and effectiveness of their maintenance procedures, thus reducing transmission asset outages.

This paper focuses on the penalties due to unexpected outages, since these are usually caused by faults. Knowing the fault location accurately can reduce the duration of the line unavailability. The VP portion due to unexpected outages is calculated according to (11) [12].

$$VP = \frac{MR}{1440 \cdot D} (K_0 \cdot \sum_{i=1}^{NO} UO_i) \quad (11)$$

where:

VP is the variable portion to be subtracted from the monthly revenue for the specific transmission asset due to the unavailability caused by unexpected outages in that month.

MR is the monthly revenue for the specific transmission asset. It is equal to AR/12.

D is the number of days of the month in consideration.

$K_0$  is the multiplication constant of the asset unexpected outages. For an overhead transmission line,  $K_0 = 150$  for the first 300 minutes of outage, then it is reduced to 10.

NO is the number of unexpected transmission line outages for the month in consideration.

$UO_i$  is the duration in minutes of the unexpected transmission line outage  $i$ .

Certain situations of transmission line outages are not considered for the calculation of the VP value, such as:

- Transmission line outages of less than one minute.
- Transmission line outages requested by the ISO for operation reasons.
- Transmission line outages requested by TGC for human safety concerns.
- Transmission line outages due to a contingency in another transmission system asset, like a line trip by remote backup protection, except in cases of incorrect tripping of the protection system or failure of the TGC to follow predefined procedures.
- Transmission line outages due to correct operation of remedial action schemes.
- Transmission line outages during the first six months of operation.
- Transmission line outages due to force majeure conditions, acts of sabotage or terrorism, a declared state of emergency by local authorities, or third-party safety issues, among others.

Reference [13] provides an example of a penalty applied in Brazil for a single two-minute outage on a 345 kV transmission line, where the MR value is \$658,681.45 in United States dollars (USD). All monetary values are in USD and account for the exchange rate from Brazilian Reais (BRL) to USD at the time and month of the outage. The VP value calculated per (11) for the aforementioned outage is \$4,574.17, equivalent to \$2,287.08/minute.

Every minute saved in a transmission line outage represents a considerable amount of money, making a reliable and accurate fault location system an important requirement for any TGC. Moreover, if the system includes LIMO functionality, it is possible to act on the root cause of incipient faults before they cause a sustained fault and a line interruption, as explained in Section III.

The Brazilian transmission system is comprised of many long lines, several of them with sections of difficult access. Dispatching terrestrial patrols to find the failure without accurate fault location information increases the outage duration and the monetary loss.

As already mentioned, vegetation growing under the line is one potential cause of permanent faults. The first faults caused by vegetation are frequently not permanent. If the problematic location can be pinpointed by the accurate fault location system and LIMO, then vegetation can be trimmed and managed before it creates a sustained outage.

Reference [14] is the notice of a \$225,000 penalty imposed on a TGC in the United States for sustained faults caused by vegetation growing under a transmission line. According to the notice of penalty, the terrestrial patrol was dispatched after a second momentary outage in an attempt to find the root cause of the two transmission line trips. However, the patrol missed the site with overgrown vegetation because they did not have accurate location information and the area was difficult to access. After a third line trip, an aerial patrol was dispatched

and eventually located the cause. If an accurate fault location system had been in place, the terrestrial patrol could have been sent to the problematic location immediately and the additional cost of the aerial patrol and the increased penalty could have been avoided.

The Brazilian regulation also requires the TGCs to inform the proper authorities of the causes of unexpected transmission line outages. Without knowing the exact fault location, this task can be nearly impossible. It is difficult to inspect each section of the transmission line in an attempt to spot failed insulators or vegetation encroachment that could have caused a fault. An accurate fault location system would provide an invaluable aid for creating the mandatory fault reports required by regulatory agencies and ISOs.

## V. BRAZILIAN BULK POWER SYSTEM TRANSMISSION LINE FAULT STATISTICS

Table II shows the main causes (though not all causes) of unexpected transmission line outages in the Brazilian bulk power system, considering a total number of approximately 12,000 events from 2016 to 2020 [15].

TABLE II  
MAIN CAUSES OF UNEXPECTED LINE OUTAGES IN THE BRAZILIAN BULK POWER SYSTEM BETWEEN 2016 AND 2020

Cause	2016	2017	2018	2019	2020
Lightning	24.8%	26.9%	27.2%	27.7%	22.8%
Undetermined	22.2%	13.2%	15.9%	13.8%	12.5%
Fire	19.2%	25.1%	14.9%	22.9%	32.2%
Vegetation	8.5%	8.1%	9.2%	7.8%	7.0%
Rainstorm	4.7%	3.0%	3.3%	2.1%	2.7%
Gale	3.2%	4.2%	2.9%	5.4%	6.0%
Broken conductor	1.0%	1.1%	0.8%	1.7%	0.9%
Bird waste	3.4%	3.6%	9.3%	4.1%	5.5%
Tower fall	1.5%	0.4%	0.8%	0.6%	0.4%
Insulator contamination	2.1%	3.3%	2.2%	1.0%	0.5%
Instrument transformer failure	0.7%	0.4%	1.0%	1.4%	1.0%

The Brazilian bulk power system had 1,249 transmission lines at the end of 2020, totaling 147,928 km (91,918 mi), which gives an average length of about 119 km/line (74 mi/line) [15].

Despite the request from the regulatory agency ANEEL to the TGCs of reporting the cause of the transmission line trips, there are many occurrences where the cause is undetermined. The lack of accurate fault location information for long transmission lines that cross terrains of difficult access is a contributing factor to this high number of undetermined causes of line trips. Table II shows a significant reduction in the

undetermined cause classification for line trips from 2016 to 2020. This reduction is mainly due to the campaign by ANEEL, which worked one-on-one with the TGCs since 2016 to request improvement plans for line outages analysis [15].

Accurate fault location and high-resolution event record information can be extremely helpful in determining the cause of line faults, and in conducting the required maintenance or repair actions. This approach reduces the number of future outages caused by similar reasons, increases transmission line availability, and enhances the bulk power system reliability.

As mentioned in Section III, the LIMO function has the potential to detect and locate precursor events associated with:

- Bird waste contamination of insulators.
- Chemical/pollution contamination of insulators.
- Vegetation growth under the transmission line.
- Fire along the line right-of-way.
- Insulator deterioration due to aging and hidden failures.

These possible fault causes represent around 33 percent of the line outage causes reported in Table II.

## VI. TERNA PLUS CASE STUDY

In addition to having responsibility for other assets, Terna Plus is responsible for the operation of two transmission lines belonging to the Brazilian bulk power system. This section provides the technical characteristics of these transmission lines and the contractual details of the concessions. We also analyze line outages and explain the motivations that led Terna Plus to adopt a fault-locating and predictive monitoring system for these transmission lines.

### A. Cuiabá–Jauru C2 500 kV Transmission Line (TL1)

The transmission line Cuiabá–Jauru C2 (TL1) was first energized in April 2019. This single-circuit 500 kV line has a length of 355 km (221 mi) and interconnects the Jauru and Cuiabá substations. The line connects to breaker-and-a-half bus arrangements at both terminals.

According to [16], the AR for TL1 is \$16,805,555, considering the exchange rate from BRL to USD at the date of the concession contract signature (March 11, 2016), resulting in an MR of \$1,400,462. Using (11) we can calculate the penalty per minute for unexpected line outages that fall under the conditions described in Section IV, considering a 30-day month:

$$VP = \frac{1,400,462}{1,440 \cdot 30} (150 \cdot 1) = \$4,862/\text{minute} \quad (12)$$

Avoiding only three minutes of unexpected outages for this specific transmission line saves enough in penalty fees to justify the installation of a modern microprocessor-based protective relay that includes a sophisticated and accurate multimethod fault-locating system.

Table III shows the number of unexpected outages for TL1 and the causes in 2019 and 2020.

TABLE III  
UNEXPECTED OUTAGES DUE TO INTERNAL REASONS—TL1

Cause	2019	2020
Lightning	1	1
Fire	1	0
Undetermined	6	8
Total	8	9

### B. Santa Maria 3–Santo Ângelo 2 C1 230 kV Transmission Line (TL2)

The transmission line Santa Maria 3–Santo Ângelo 2 C1 (TL2) was first energized in October 2018. This single-circuit 230 kV line has a length of 159.83 km (99 mi) and interconnects the Santo Ângelo 2 and Santa Maria 3 substations. The line connects to breaker-and-a-half bus arrangements at both terminals.

According to [17], the AR for TL2 is \$4,435,850, considering the exchange rate from BRL to USD at the date of the concession contract signature (January 18, 2016), resulting in an MR of \$369,655. Using (11), we can calculate the penalty per minute for unexpected line outages that fall under the conditions described in Section IV, considering a 30-day month:

$$VP = \frac{369,655}{1,440 \cdot 30} (150 \cdot 1) = \$1,284.00/\text{minute} \quad (13)$$

In the case of this transmission line, avoiding only ten minutes of unexpected outages justifies the installation of a modern microprocessor-based protective relay that includes a sophisticated and accurate multimethod fault-locating system.

Table IV shows the number of unexpected outages for TL2 and the causes in 2019 and 2020.

TABLE IV  
UNEXPECTED OUTAGES DUE TO INTERNAL REASONS—TL2

Cause	2019	2020
Lightning	4	7
Fire	0	0
Undetermined	3	2
Total	7	9

### C. Fault Locating and Line Monitoring Solution

When TL1 and TL2 were energized, only the SEZFL method, available in the line protection relays, was used for fault locating. The difficulty in locating and identifying the cause of unexpected line outages is evident from the undetermined causes for line outages shown in Table III and Table IV. Even in cases where the line is automatically reclosed successfully, a failure to identify the fault location and the cause of the unexpected outage is critical because the fault can occur

again in the same location and for the same reason. Pinpointing repetitive fault locations is key to avoiding future sustained faults that cause unexpected line outages, which will reduce costly penalties, as discussed in previous sections.

Motivated by the high number of unexpected line outages in the first two years of operation of the lines and the difficulty in determining the causes, Terna Plus implemented an advanced fault-locating and LIMO system in order to reduce the duration and the number of unexpected line outages. To this end, Terna Plus applied UHS line protection relays that provide a multimethod fault location system including DETWFL, DEZFL, SETWFL, and SEZFL methods. Communications channels between the substations are available for the DETWFL method, which ensures the accuracy and promptness of the fault location information. Making this information available to the maintenance crews allows for fast line repair and reduces the line outage duration. Another decisive factor for Terna Plus's choice was the inclusion of the SETWFL method in the fault-locating system, so in the event of a failure in the global time-synchronization system, this method works as a backup. Based on the available communications channels, the system is capable of reporting in real time the fault location provided by the DETWFL, SETWFL, and SEZFL methods, and is also capable of applying all four methods for offline calculations.

The LIMO function is used to log fault precursor and fault events in order to help maintenance crews inspect specific sections of TL1 and TL2, take preventive actions, and avoid possible future line outages.

All substations have communications multiplexers with IEEE C37.94 channels available. Since the communications channel between the UHS line protection relays is not via a direct optical fiber, it is necessary to provide external time synchronization for the DETWFL function.

Fig. 10 shows the simplified diagram of the TL1 protection and monitoring system. The line has shunt reactors at both ends, but they are not connected to the line through circuit breakers, so there is no need to monitor their current, since they are switched only when the line is not energized. In the original design of the protection systems, the currents from the two sets of CTs at each terminal are summed externally to the relay by paralleling the CTs. This configuration was kept in order to reduce panel wiring work, even though the new UHS relays are capable of measuring the two sets of currents independently.

Fig. 11 shows the simplified diagram of the TL2 protection and monitoring system. The TL2 shunt reactor is connected through a circuit breaker, so it can be switched on and off while the line is in operation. In order to avoid false detection of events by the LIMO function when the reactor is switched, the CTs from the shunt reactor are connected to the UHS relay to compensate for the TWs generated during shunt reactor switching.

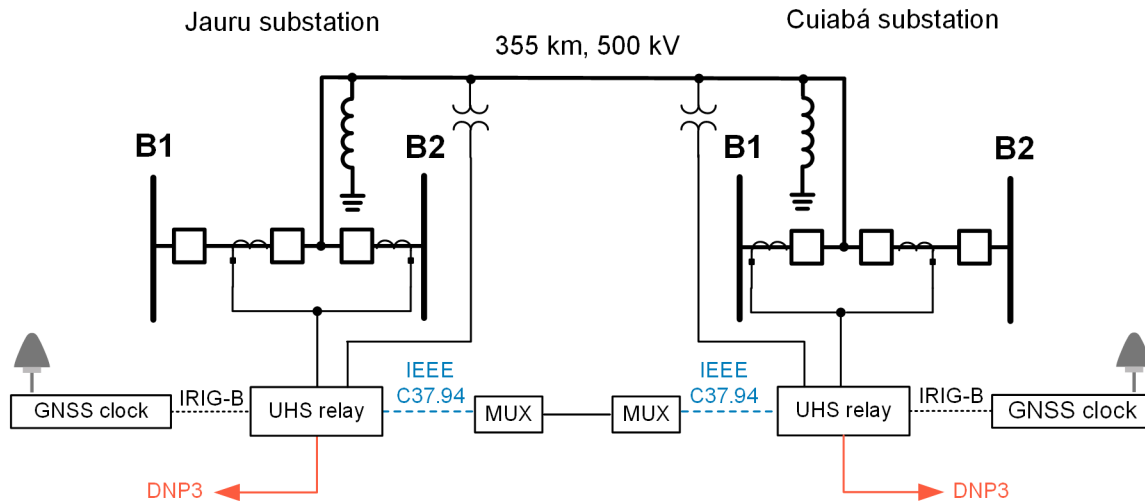

Fig. 10. SLD TL1 protection and monitoring system.

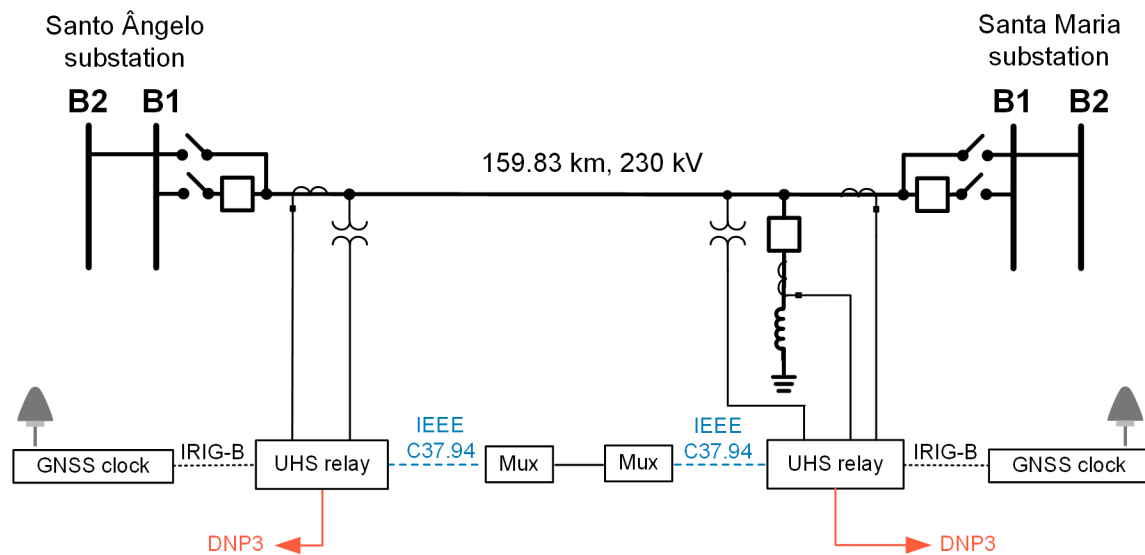

Fig. 11. SLD TL2 protection and monitoring system.

As mentioned before, for the DETWFL, SETWFL and SEZFL methods, the UHS relays execute the fault-locating algorithm in real time and send the result promptly to the control center via the DNP3 protocol; no further data processing is required at the control center. The relays automatically determine the best result among the three methods and submit that single result to the user. The fault location provided by the other methods is also available for automatic sending via communication and in the event report file.

The highest priority is always for the DETWFL method result. However, if this method is unavailable, either due to a communications failure or the absence of a high-precision external time-synchronization signal, the relay reports the best result between the two single-ended methods, since the DEZFL method is not being used.

In applications with communication via IEEE C37.94, the DEZFL method is not available for automatic calculation. Offline calculation is possible and easy to perform using an event report analysis software [2] [18].

The combination of one- and two-terminal methods based on impedance and TWs is important to ensure availability of fault locating in adverse conditions, such as:

- Failure in the external time synchronization— DETWFL is unavailable and SETWFL, SEZFL, and DEZFL (offline) methods are available.
- Loss of communication between substations— DETWFL is unavailable and SETWFL, SEZFL and DEZFL (offline) methods are available.
- Faults occurring when voltage is near the zero-crossing— DETWFL and SETWFL are unavailable and SEZFL and DEZFL (offline) methods are available.

In the case of communications failure between one of the substations and the control center, the fault location information is still sent by the relay located in the substation with healthy communication to the control center. In the case that the two substations lose communication with the control center, the

fault location information from all methods is still available locally in each relay.

### 1) Fault Locating Settings

Table V lists the settings required to enable the fault-locating function in the relays and the settings values determined for each of the Terna Plus transmission lines.

TABLE V  
FAULT LOCATING SETTINGS FOR TL1 AND TL2

Setting	TL1	TL2
$Z_{L1}$ ( $\Omega$ sec)	103.77 $\angle$ 86.06°	11.06 $\angle$ 83.26°
$Z_{L0}$ ( $\Omega$ sec)	391.71 $\angle$ 71.36°	42.29 $\angle$ 70.71°
LL (km)	355	159.83
TWLPT ( $\mu$ s)	1207.50	543.64
FL <sub>TRIGGER</sub>	TRIP OR IN103	TRIP OR IN103

The line positive-sequence impedance ( $Z_{L1}$ ) and zero-sequence impedance ( $Z_{L0}$ ) setting values were directly determined from the line characteristics data. Reference [19] provides guidance and discusses the challenges of accurately determining the actual line length (LL) value.

TWLPT is the total TW propagation time on the transmission line. As an initial configuration, it is assumed to be equal to 98 percent of the speed of light. During system commissioning, the actual value is measured with a line energization test.

FL<sub>TRIGGER</sub> is a logic equation that triggers the fault-locating function. The device applied in this project is a UHS line protection relay, which implements the protection functions based on incremental quantities and TWs. All protection elements are enabled, so the relay is able to detect internal faults and trigger the fault-locating function with the trip signal (TRIP) issued by the protection elements. Additionally, the relay receives the trip signals of other relays via digital inputs to perform line protection functions and also uses these trip signals to trigger the fault-locating function. The following protection functions are enabled in the relays:

- Underreaching incremental-quantity phase (TD21P) and ground (TD21G) distance protection elements
- Permissive overreaching transfer trip logic over IEEE C37.94 communications channel with traveling-wave (TW32) and incremental-quantity (TD32) directional elements

Initially, the UHS protection functions will not be applied to trip the circuit breakers in order to evaluate their performance. Terna Plus intends to have these elements tripping the circuit breakers after a successful evaluation period.

### 2) LIMO Settings

The LIMO function operates based on the DETWFL function for locating fault precursors. It uses a disturbance detection function based on TWs for triggering the event locating algorithm. The only settings to configure in order to enable LIMO are the following:

- Enable Line Monitoring (ELM)
  - N—disable the line monitoring function
  - Y—enable the line monitoring function to tabulate faults and events
  - YE—enable the line monitoring function to tabulate events only
  - YF—enable the line monitoring function to tabulate faults only
- Line Monitoring Alarm Threshold (LMALARM), which is the number of events detected in a specific bin along the line for alarming

It is also possible to define blocking regions for the LIMO function where the events generated in those locations will not be counted. An example is a load tap in the line, which could cause TW reflections not related to a fault. The Terna Plus application does not require blocking regions because the lines have no taps.

### 3) Installation, Testing, and Commissioning

In all substations, the UHS relays will be installed in the existing protection and control panels in order to take advantage of the digital and analog signals already available in these panels, such as currents, voltages, and digital status signals.

Factory acceptance tests (FATs) and site acceptance tests (SATs) are required to fully test the protection, fault-locating, and LIMO functions.

Since the devices will be installed in existing panels, the FATs will mainly validate the settings configuration and the communication with the supervisory system through the DNP3 protocol to report fault location and other data in real time. Additionally, the FATs are an opportunity for Terna Plus engineers to learn about the relay functionalities.

Fig. 12 shows the FAT setup that is used for testing the fault-locating and predictive monitoring system. The amplifiers of conventional relay test sets do not have the frequency bandwidth required for testing TW-based functions. An additional test module is used as the TW test source, shown in Fig. 12, to test the TW functions. This module superimposes a high-frequency pulse on the signal provided by the conventional relay test set. A GNSS clock synchronizes the conventional test set and the TW test source so that the injection takes place at the desired time. The setup shown in Fig. 12 allows for the testing of all relay functions.

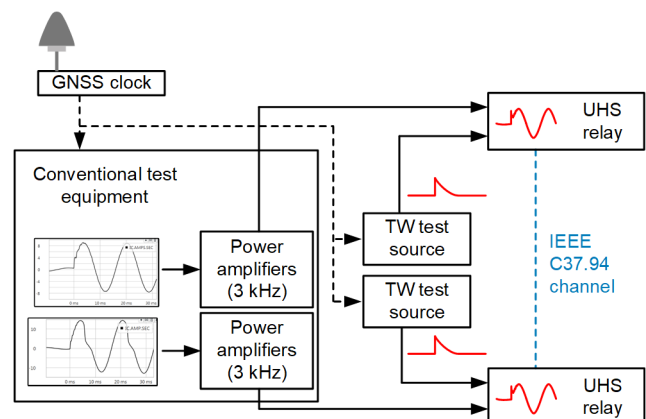

Fig. 12. FAT setup.

An FAT helps users determine if the device or the system complies with the application requirements and confirms the correct performance of the configured logic and settings. This type of test can also use a transient power system simulation and analysis software, with a realistic modeling of the specific power system. This option allows users to simulate a high number of testing scenarios and generates waveform files for each. The UHS relays have a built-in event playback testing feature. The waveform files are used in conjunction with this feature to test the protection and fault-locating functions without the need for a physical test set [20].

For an SAT, each device is installed in a substation and the same testing strategy can be used. However, it is necessary to time-synchronize the test set equipment with GNSS clocks at both substations, as shown in Fig. 13.

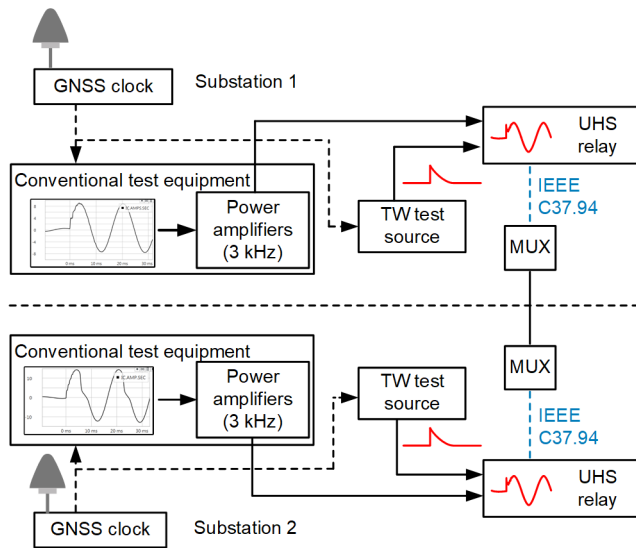

Fig. 13. SAT setup.

## VII. ADDITIONAL BENEFITS

A UHS relay samples currents and voltages every microsecond (a sampling rate of 1 MHz) in order to extract TWs from raw current and voltage signals. The relay uses this information to provide TW-based protection and fault-locating functions. It also stores oscillographic records captured according to user-defined triggers.

The relay time-stamps its high-resolution oscillographic records with an accuracy of 100 nanoseconds or better in reference to the absolute time reference when connected to a high-precision time source. The oscillographic records retrieved from different relays can then be time-aligned, and multiple records can be analyzed together. These records can

be used to analyze high-frequency components of voltages and currents, such as those caused by transient recovery voltage (TRV) events in circuit breakers. These events can occur in the substation where the relay is located or in an adjacent substation. TRV is the voltage appearing across the terminals of the circuit breaker poles after a switching action to interrupt the current, as shown in Fig. 14 [21].

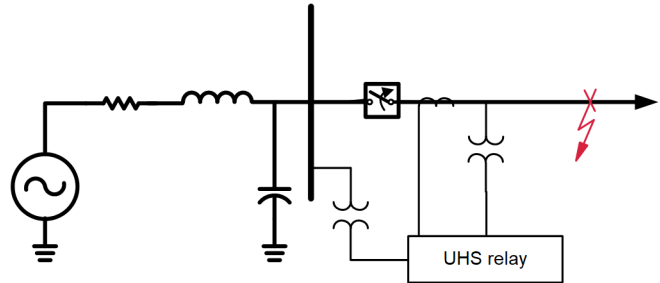

Fig. 14. Circuit breaker switching to clear a line fault.

TRV is a short-duration transient with high amplitude and high frequency. The rapid change in voltage can damage power system equipment and result in insulation failures, circuit breaker arc re-ignition, breakdown, and external flashover.

The TRV withstand capability is a specification item for circuit breakers, and it is provided in data sheets. It is specified in terms of voltage peak value and the time in microseconds that the voltage takes to reach the peak. Applying UHS relays, as depicted in Fig. 14, makes it possible to capture voltages and currents for circuit breaker operations with a 1 MHz sampling rate to verify that the actual TRV is within the circuit breaker withstand capability or to detect potential problems with the circuit breaker during the interruption process.

During the process of interrupting a fault current, an arc is established between the contacts of the circuit breaker. The arc loses conductivity rapidly as the current approaches zero, and, a few microseconds after the current zero-crossing, current stops flowing and the arc ceases. During this process, the dielectric medium must recover its insulation property faster than the rate of change of the recovery voltage across the contacts and continue preventing the current flow. The interruption is successful if the interrupting medium can withstand the fast TRV rate of change. However, if the dielectric medium deteriorates because of the TRV, a dielectric breakdown takes place, causing the dielectric medium to become conductive and the current to start flowing again. This phenomenon is called re-ignition. Fig. 15 shows an example of current re-ignition captured by a UHS relay where the current flow was reestablished just after the zero-crossing.

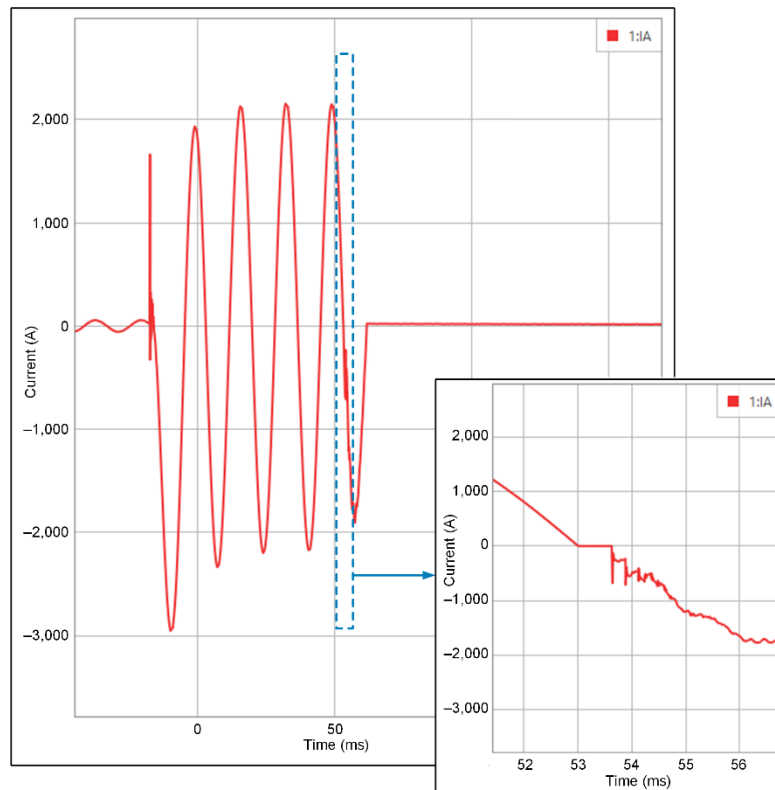

Fig. 15. Circuit breaker current reignition event captured by a UHS relay.

This type of phenomenon cannot be detected by traditional protective devices that have low sampling rates. The circuit breaker reignition event is not visible in the relay report and the circuit breaker is considered to be operating normally. As shown in Fig. 15, the high sampling rate of UHS relays allows for the detection of circuit breaker restrikes and other high-frequency, low-duration power system events.

Circuit breaker current reignition has harmful effects on the power system because of the longer time to clear the fault. In addition, the circuit breaker fails to interrupt the current and may explode, causing extensive material damage and compromising power system reliability.

High-resolution oscillographic records reveal high-frequency events in the power system that cannot be seen via other methods. Without this visibility, the events go unnoticed, maintenance or repairs remain unscheduled, and the power system continues to operate in an unsafe state. With this visibility, however, the utility can conduct performance-based maintenance to enhance the reliability and performance of the electric power system.

## VIII. CONCLUSION

A highly accurate, real-time, and multimethod fault-locating system is an essential tool for TGCs. This system provides many advantages, including faster detection and repair of failures in transmission lines, reduction of costly line inspections, improvement in line crew maintenance productivity, and better visibility of the line outage causes. Additionally, this system reduces overall line outage duration resulting in fewer penalties and an improvement in quality of service to the customers.

The LIMO function has a high potential of reducing the number of line faults and unexpected line outages by indicating the location where repetitive fault precursors occur. This information allows the line maintenance crew to fix the problem in the transmission line before a sustained fault occurs.

The high-resolution oscillography provided by UHS relays allows the analysis of high-frequency phenomena in the power system.

The monetary penalties due to transmission line outages are very high in some countries. Reducing these penalties easily justifies the investment to install highly accurate fault-locating systems.

Modern UHS relays have the processing capability and communications required to seamlessly provide UHS protection, TWFL, and high-resolution oscillography.

## IX. REFERENCES

- [1] E. O. Schweitzer, III, "A Review of Impedance-Based Fault Locating Experience," proceedings of the 15th Annual Western Protective Relay Conference, Spokane, WA, October 24–27, 1988.
- [2] K. Zimmerman and D. Costello, "Impedance-Based Fault Location Experience," proceedings of the 31st Annual Western Protective Relay Conference, October 2004.
- [3] O. Avendano, B. Kasztenny, H. J. Altuve, B. Le, and N. Fischer, "Tutorial on Fault Locating Embedded in Line Current Differential Relays—Methods, Implementation, and Application Considerations," proceedings of the 41st Annual Western Protective Relay Conference, Spokane, WA, October 14–16, 2014.
- [4] B. Shulim, Y. Gong, M. Mynam, A. Guzmán, and G. Benmouyal, "Automated Fault Location System for Nonhomogeneous Transmission Networks," proceedings of the 65th Annual Conference for Protective Relay Engineers, College Station, TX, April 2–5, 2012.

- [5] S. Marx, A. Guzmán, V. Skendzic, and M. V. Mynam, “Traveling Wave Fault Location in Protective Relays: Design, Testing, and Results,” proceedings of the 16th Annual Georgia Tech Fault and Disturbance Analysis Conference, Atlanta, GA, May 6–7, 2013.
- [6] E. O. Schweitzer, III, A. Guzmán, M. V. Mynam, V. Skendzic, B. Kasztenny, and S. Marx, “Locating Faults by the Traveling Waves They Launch,” proceedings of the 40th Annual Western Protective Relay Conference, October 2013.
- [7] B. Kasztenny and V. Mynam, “Line Length and Fault Distance Considerations in Traveling-Wave Protection and Fault-Locating Applications.” Available: [selinc.com/api/download/134423](http://selinc.com/api/download/134423).
- [8] D. L. Corton, J. V. Melado, J. Cruz, R. Kirby, Y. Z. Korkmaz, G. Patti, and G. Smelich, “Double-Ended Traveling-Wave Fault Locating Without Relay-to-Relay Communications,” proceedings of the 74th Annual Conference for Protective Relay Engineers, March 22–25, 2021.
- [9] SEL-T400L Time-Domain Line Protection Instruction Manual. Available: [selinc.com/products/T400L/docs/](http://selinc.com/products/T400L/docs/).
- [10] A. Guzmán, B. Kasztenny, Y. Tong, and M. V. Mynam, “Accurate Single-End Fault Locating Using Traveling-Wave Reflection Information,” 14th International Conference on Developments in Power System Protection, Belfast, United Kingdom, March 12–15, 2018.
- [11] B. Kasztenny, M. V. Mynam, T. Joshi, and D. Holmbo, “Preventing Line Faults with Continuous Monitoring Based on Current Traveling Waves,” 15th International Conference on Developments in Power System Protection, Liverpool, United Kingdom, March 9–12, 2020.
- [12] Agência Nacional de Energia Elétrica (ANEEL), “Resolução Normativa no. 729, de 28 de Junho de 2016.” Available: [aneel.gov.br/cedoc/ren2016729.pdf](http://aneel.gov.br/cedoc/ren2016729.pdf).
- [13] R. M. Aquino and M. H. M. Vale, “Impacto da Parcela Variável na Expansão, Operação e Manutenção do Sistema Interligado Nacional—Propostas para Atualização de Procedimentos,” XX SNPTEE, Recife, Brazil, November 22–25, 2009.
- [14] North American Electric Reliability Corporation (NERC), “Notice of Penalty NERC Violation ID RFC200800071.” Available: [nerc.com/pa/comp/CE/Pages/Actions\\_2009/2009\\_TABLE.htm](http://nerc.com/pa/comp/CE/Pages/Actions_2009/2009_TABLE.htm).
- [15] Agência Nacional de Energia Elétrica (ANEEL), “Dados Estatísticos da Transmissão.” Available: [aneel.gov.br/fiscalizacao-da-transmissao](http://aneel.gov.br/fiscalizacao-da-transmissao).
- [16] Agência Nacional de Energia Elétrica (ANEEL), “CONTRATO DE CONCESSÃO NO. 07/2016-ANEEL.” Available: [aneel.gov.br/contratos1](http://aneel.gov.br/contratos1).
- [17] Agência Nacional de Energia Elétrica (ANEEL), “CONTRATO DE CONCESSÃO NO. 03/2016-ANEEL.” Available: [aneel.gov.br/contratos1](http://aneel.gov.br/contratos1).
- [18] Swagata Das, “Impedance-Based Fault Location Using Custom Calculations in SYNCHROWAVE Event.” Available: [selinc.com](http://selinc.com).
- [19] B. Kasztenny, “Improving Line Crew Dispatch Accuracy When Using Traveling-Wave Fault Locators,” proceedings of the 46th Annual Western Protective Relay Conference, Spokane, WA, October 22–24, 2019.
- [20] A. Guzmán, G. Smelich, Z. Sheffield, and D. Taylor, “Testing Traveling-Wave Line Protection and Fault Locators,” proceedings of the 14th International Conference on Developments in Power System Protection, March 2018.
- [21] IEEE C37.011-2011, *IEEE Guide for the Application of Transient Recovery Voltage for AC High-Voltage Circuit Breakers*.

## X. BIOGRAPHIES

**Artur Hoff** received his BSEE degree in electrical engineering from the Technological Sciences Center in Joinville, Brazil, in 1997. In 1998, he joined Cia. de Cimento Itambé as a design engineer. In 2000, he joined Siemens as a commissioning engineer and works coordinator, and later became a contract engineer. In 2008, he joined Novatrans Energia (Terna Participações), in the role of control engineer, becoming maintenance coordinator and then management manager. In 2018, he joined SPE Santa Lúcia and SPE Santa Maria as a design engineer, later becoming engineering manager. He is currently working as technical director of Terna companies in Brazil.

**Ricardo Abboud** received his BSEE degree in electrical engineering from Federal University of Uberlândia, Brazil, in 1992. In 1993, he joined CPFL Energia as a protection engineer. In 2000, he joined Schweitzer Engineering Laboratories, Inc. (SEL) as a field application engineer in Brazil, assisting customers in substation protection, automation, and control systems. In 2005, he became the field engineering manager, leading and mentoring the application engineering group, and in 2014, he became the engineering services manager. In 2016, he transferred to SEL headquarters in Pullman, Washington, as an international technical manager, providing advanced technical support and consultancy about new technologies to international field offices. In 2019, he joined SEL University as a professor. Currently, he is a principal engineer with SEL Engineering Services, Inc. (SEL ES).

**Renan Bernardes** received his BSEE degree in electrical engineering from Universidade Federal de Itajubá, Brazil, in 2007. In 2008, he joined Schweitzer Engineering Laboratories, Inc. (SEL) as an application engineer in Brazil for substation protection, automation, and control systems. In 2013, he became technical support group supervisor. In 2015, he joined Neoenergia working as a protection and automation engineer for transmission assets. In 2019, he returned to SEL, where he currently works as a sales and customer service manager.

**Paulo Lima** received his BSEE in electrical engineering from Universidade Federal de Itajubá, Brazil, in 2012. In 2013, he joined Schweitzer Engineering Laboratories, Inc. (SEL) as a protection application engineer in Brazil. In 2018, he became application engineering group coordinator, and has been the regional technical manager for Brazil since 2020. He has experience in application, training, integration, and testing of digital protective relays. He also provides technical writing and training associated with SEL products and SEL University.