

Line Current Differential Protection in Systems With Inverter-Based Resources—Challenges and Solutions

Ritwik Chowdhury, Ryan McDaniel, and Normann Fischer, *Schweitzer Engineering Laboratories, Inc.*

Abstract—Line current differential (87L) elements are popular for line protection and can provide excellent security and dependability. In systems with inverter-based resources (IBRs), the elements may exhibit reduced dependability and, in cases when not applied properly, degraded security.

This paper presents challenges and solutions to 87L applications in systems with IBRs. The solutions consist of settings guidelines that can be used to significantly improve dependability and security in such applications. The solutions may be generalized to other challenging applications, such as series-compensated lines with a possibility of current inversion, evolving fault scenarios, or single-phase tripping applications.

I. INTRODUCTION

Line current differential (87L) elements are popular for line protection due to their immunity to issues that challenge distance protection, such as power swings, load encroachment, uncertainty of line parameters, zero-sequence mutual coupling, and requirements for short-circuit studies (such as infeed and outfeed). As a tradeoff, they require a reliable communications channel and do not provide remote backup.

The 87L elements are an excellent choice in systems with inverter-based resources (IBRs) [1]. This is particularly due to the numerous challenges faced by other line protection elements in these systems that can lead to reduced dependability [2].

However, 87L relays can also face challenges in systems with IBRs (as discussed in Section III). This paper presents solutions, primarily settings modifications, to improve the 87L element performance in systems with IBRs (as discussed in Section IV). The solutions characterize the major sources of error for the 87L element, namely, channel asymmetry and current transformer (CT) saturation. An application example showing how to improve the reliability of the 87L element is included in Section V. The guidance is not limited to systems with IBRs and can be generalized to other applications.

II. 87L ELEMENT OVERVIEW

A. 87L Element Requirements and the Alpha Plane

The circuit relevant to the 87L element is shown in Fig. 1. The impact of the different sources of error on the 87L element performance is summarized in Table I. A major source of error for the 87L element is the channel. Applications with direct fiber communications channels have minimal asymmetry.

Typical channels have asymmetries below 2 milliseconds; however, in rare cases, channels with multiplexers can have asymmetries as high as 5 milliseconds if not synchronized using an external reference [3].

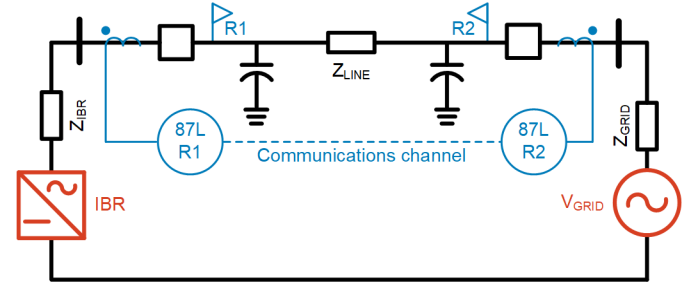

Fig. 1. Circuit relevant for 87L element

TABLE I
IMPACT OF ERRORS ON 87L ELEMENT SECURITY AND DEPENDABILITY

Source of Error	Security	Dependability
Channel asymmetry	Major	Moderate
CT saturation (during transients)	Major (can misoperate)	Minor (can delay tripping)
Line-charging current	Minor with compensation, otherwise can be moderate	Minor
Steady-state CT and relay errors	Minor	Minor
System nonhomogeneity	No effect	Moderate

The asymmetry in the channel translates to an angular error for the 87L element but does not impact the magnitude. The alpha plane (87AP) is developed to take advantage of this observation and can be represented by the logic of Fig. 2, with the radius and angle settings illustrated in Fig. 3, where I_L and I_R are the current phasors at the local and remote line terminals or are calculated equivalents [4].

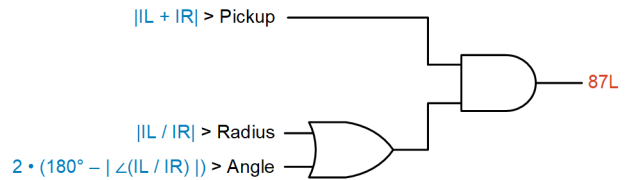

Fig. 2. Simplified logic for the 87L element using the alpha-plane principle

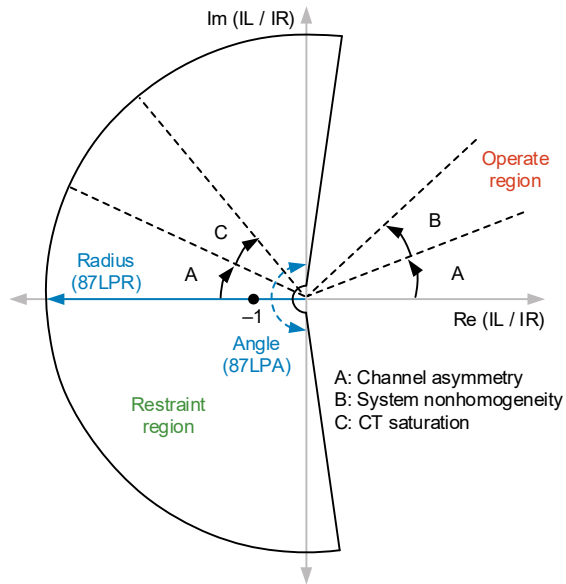

Fig. 3. Alpha-plane characteristic, settings, and associated errors

The operating characteristic associated with the 87AP logic of Fig. 2 is commonly represented by Fig. 3, assuming the element pickup is satisfied. The 87L element is further divided into three subelements:

- Phase element (87LP)—the 87LP element performs a per-phase differential (i.e., 87LA, 87LB, and 87LC) to detect all fault types: line-to-ground (LG), line-to-line (LL), line-to-line-to-ground (LLG), and three-phase (3P).
- Zero-sequence element (87LG)—LG faults can have high fault resistance [5]. The 87LG element complements the 87LP element by adding sensitivity for ground faults. The 87LG element has also been applied in tapped line applications where the tapped transformer has a delta winding on the high-voltage side and presents an open-circuit in the zero-sequence network. This means that the current downstream of the tap, with possibly expensive equipment associated with the additional line terminal, is not required by the 87LG element to remain secure for faults downstream of the tapped transformer.
- Negative-sequence element (87LQ)—the 87LQ element complements the 87LP element by adding sensitivity for all unbalanced faults. In relation to the 87LG element, the 87LQ element primarily adds sensitivity to LL/LLG faults with resistance. While multiphase faults are typically considered to have small fault resistance, field events have shown that this is not always the case [5] [6].

The 87AP element settings correspond to the restraint region shown in Fig. 3. Most utilities use the default values shown in Table II, where the settings have a per-unit (pu) base of the CT primary current rating. The alpha-plane operating principle has been applied to protect thousands of lines for over 20 years [7].

TABLE II
COMMON SETTINGS AND DEFAULTS FOR THE 87L ELEMENT

Setting	87LP	87LG	87LQ
Pickup	1.20 pu	0.25 pu	0.25 pu
Radius	6	6	6
Angle	195 degrees	195 degrees	195 degrees

B. 87L Security for CT Saturation

1) External Fault Detector (87EFD)

The 87L element security for CT saturation may be addressed by use of an external fault detector (87EFD) to allow the relay to have two operating modes, a sensitive mode (when $87EFD = 0$), and a secure mode (when $87EFD = 1$) [8]. While the secure mode is required to address the major source of transient error associated with CT saturation (see Table I), the sensitive mode must only account for steady-state errors.

When there is a possibility of CT saturation, 87EFD asserts, and the relay uses secure mode settings. The alternating-current (ac) 87EFD shown in Fig. 4 can assert due to a significant increase in restraint current (DIRT) with little corresponding increase in operating current (DIOP). It can also assert if there is excess direct current (dc) in any of the zone currents. The dc 87EFD primarily improves 87L element security when energizing a transformer or reactor external to the 87L zone [9] [10] [11].

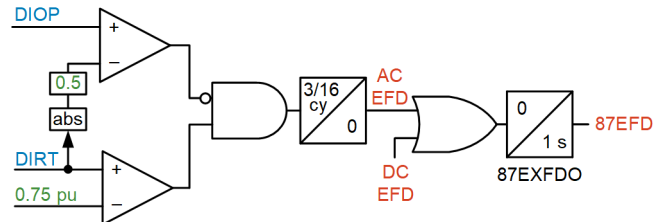

Fig. 4. Simplified 87EFD logic used to switch 87L element to secure mode

As noted previously, the sensitive settings of the relay are typically left to the values shown in Table II. The secure mode settings are approximately 20 percent higher by default to add security to the 87AP element.

2) Sequence Element Security

The larger blocking region in secure mode is adequate to secure the 87LP element. However, the sequence differential elements (i.e., 87LG and 87LQ) may not inherently have a restraint, for instance, during a 3P fault. In relays without an 87EFD, they are blocked by the presence of dc and second harmonics [7] [12]. In relays with an 87EFD, their restraint is boosted by the fundamental phase currents and harmonics, so they are permitted to operate using secure mode settings, hence remaining dependable [8].

The sequence differential elements may lose dependability for internal faults with CT saturation, but since their objective is to complement the 87LP element by detecting low-current internal faults, this has historically not been an issue.

3) Settings Philosophy for Relays With the 87EFD

It is worth noting that the secure mode settings of a relay with the 87EFD can reuse the values shown in Table II [8], since a relay without an 87EFD has used these settings and has demonstrated good performance for CT saturation for over 20 years [7].

The sensitive settings then, due to availability of the 87EFD, can be reduced to only account for steady-state errors. This is typically not done in practice. Using settings biased towards security while operating in the sensitive mode reduces dependability in systems with IBRs (as discussed in Section III.A) or other systems (as discussed in Section V.B). In Section IV.B, we provide settings guidance to improve the 87L element dependability.

C. Alpha-Plane vs. Percentage-Restrained 87L Relays

The alpha-plane (87AP) and percentage-restrained (87PCT) relays both have a pickup setting that can be set similarly and must remain secure for the relatively constant sources of errors, such as charging current. To remain secure for errors that increase with the current levels, such as channel asymmetry (linearly) and CT saturation (nonlinearly), the alpha plane offers two settings (radius and angle), unlike the percentage differential (slope) [4].

The 87AP element radius is plotted as a function of the slope of the 87PCT element for different values of blocking angles in Fig. 5 for equivalent security. For this comparison, the slope used by the 87PCT is based on a restraint that is the sum of the individual current magnitudes forming the differential zone; therefore, the slope can go up to a maximum value of 100 percent.

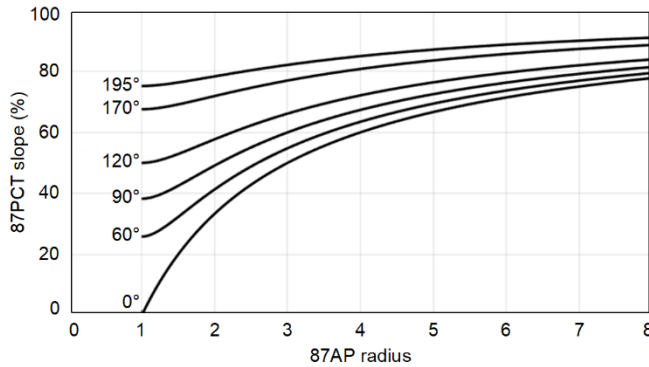

Fig. 5. 87PCT slope for different 87AP blocking radius and angle settings

The angle setting is affected by the maximum level of asymmetry expected and can be calculated using (1). For instance, a worst-case asymmetry of 5 milliseconds is associated with a blocking angle of 108 degrees in a 60 Hz system.

$$\text{Angle} = \text{Asymmetry} \cdot \text{Frequency} \cdot 360 \text{ degrees} \quad (1)$$

The default 87LP radius, and angle settings shown in Table II correspond to an 87PCT slope setting of 90 percent, which is heavily biased towards security. Settings guidance by relay manufacturers is typically not provided as a function of system parameters but has been done in the past [10]. A similar

approach is used in Section IV to provide settings guidance for relays applying the 87AP element.

III. PERFORMANCE CHALLENGES IN SYSTEMS WITH IBRS

A. Dependability Issue

An investigation into the dependability challenges of 87L relays is performed using a simulation of the power system near an approximately 1,700 MVA Type 4 wind farm and a simulation of the relay algorithm [13]. To better understand the issue, the authors of this paper contacted the authors of [13]. The simulated event from [13] is played back through relay hardware to observe the event record of Fig. 6.

The event of Fig. 6 shows the three measured phase currents at the two line terminals, with the currents at one line terminal inverted, for a 15-ohm AG internal fault. The 87EFD in Fig. 6 asserts shortly after the fault. In this case, the 87EXFDO dropout timer from Fig. 4 is shortened from 1 to 0.2 seconds to show the event more clearly. For the entire duration that 87EFD is asserted, the 87L element uses secure settings and does not operate. This means that the 87L element may not trip for this internal fault for over 1 second.

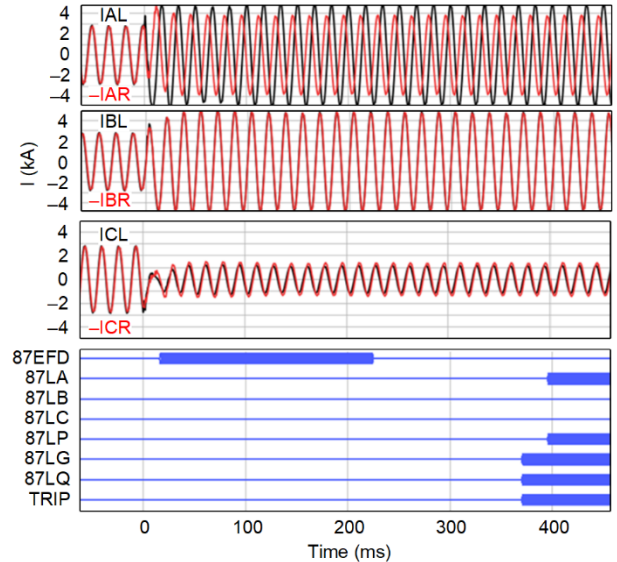

Fig. 6. 87L delayed operation (dependability issue) due to 87EFD assertion

The reason 87EFD asserts even though the fault is internal is because of the significant change in currents on the unfaulted phases. The fault is internal to the A-phase, but it is external to the B-phase and C-phase. Since an 87EFD assertion on any of the phases can switch the relay to secure mode, the element loses dependability for this scenario. In Section IV, we describe how this possible loss of dependability is not unique to systems with IBRs and discuss solutions to mitigate this issue.

B. Security Issue

In August 2019, 87L relays protecting a 0.2-mile, 138 kV line near a 184 MVA Type 3 wind farm misoperated. The associated field event report is shown in Fig. 7. The currents and voltages exhibit significant harmonic content. The 87LQ element is set sensitively with a pickup of 0.10 pu (the minimum possible setting of the relay); since the operate

current magnitude (87IQDIFM) exceeds this value, the relay trips without any fault present.

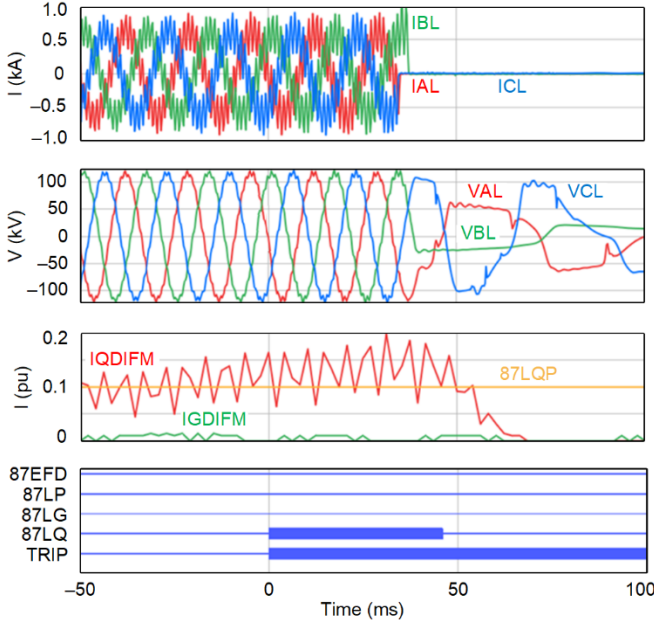

Fig. 7. 87LQ misoperates (security issue) near a Type 3 wind farm

The cause of the misoperation is attributed to the slight differences in frequency tracking at the two line terminals due to the voltage harmonic content present, which can move zero-crossings. This frequency tracking error and noisy signals, when coupled with the possibly poor negative-sequence current injected by IBRs [1], can manifest as an erroneous differential current with a magnitude ripple. IBRs have been known to produce excessive harmonics during open-phase conditions or in weak grids [14] [15].

IV. SOLUTIONS TO IMPROVE DEPENDABILITY AND SECURITY

A. CT and Relay Requirements to Address CT Saturation

This section provides the CT and relay requirements of an 87L relay with the 87EFD [8] to establish limits to security. This is important for Section V.A, where we consider an IBR application. The details of the system and the method used to develop the requirements are summarized as follows:

- A 500 kV system is used with a similar topology as the one shown later in Section V.A. The line length varies from 1 to 200 kilometers to test performance for short lines near generating plants with possibly high X/R ratios and for long lines with high-charging current.
- The X/R ratio of the fault currents varies up to a value of 100 to accommodate short-line or dual-breaker applications near generating plants.
- One terminal has dual breakers to test the requirements associated with an external fault at the dual-breaker bus where unequal saturation of the dual-breaker CTs can appear as a false differential current into the line [8].

- Only one CT is saturated for the different faults to emulate worst-case mismatch and maximize the erroneous differential current.
- CT parameters are varied and use data from both IEC 60255-187-1 and IEEE C57.13 [16] [17].
- CT remanence up to 80 percent is tested and often considered to be a good limit [10].
- The point-on-wave varies in 5-degree increments to yield greater accuracy relative to the 30-degree increments required by IEC 60255-187-1 [16].

Based on the test results, the 87AP element radius and angle required for secure behavior due to CT saturation for external faults is shown in Fig. 8. The secure settings shown in Fig. 8 are presented as a function of the total CT dimensioning required (K_{TOT}), which considers the transient dc offset and a remanence level up to 80 percent [10] [18]. This K_{TOT} value can then be used to size CTs and set the relay, as shown in the Section V.A example. The blocking radius shown in Fig. 8 corresponds to the inverse of the magnitude attenuation due to CT saturation that the relay tolerates. The blocking radius acts as a multiplier to the other lesser sources of errors. The blocking angle shown in Fig. 8 corresponds to twice the angular error associated with CT saturation. The blocking angle adds to other sources of errors, such as channel asymmetry.

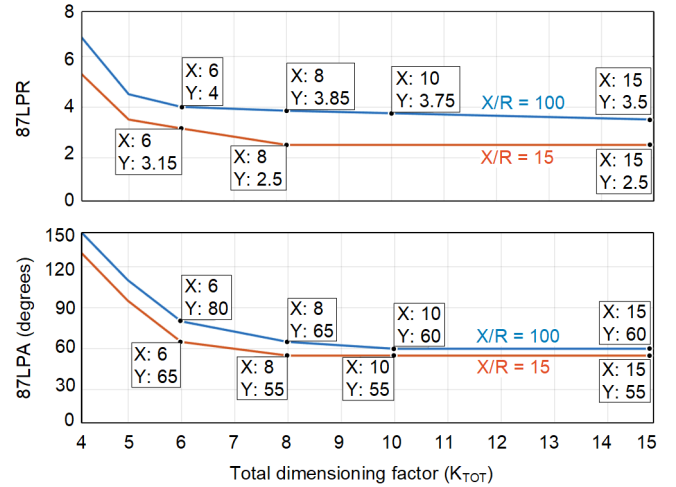

Fig. 8. 87AP blocking radius and angle requirements to accommodate CT saturation for systems up to different X/R ratios

The K_{TOT} required by the 87AP relays to perform according to the intended design is 4. Tuning settings based on CT dimensions and the X/R ratio of the worst-case external faults can add some dependability for internal faults even when 87EFD is asserted, for instance, during the example in Section III.A or during scenarios with evolving external-to-internal faults. The settings adjustments are applicable to relays without an 87EFD [7] or the secure mode settings for relays with an 87EFD [8]. The minimum K_{TOT} by the 87AP relay with an 87EFD [8] to ensure security for external faults is 2, which corresponds to such severe saturation that the 87EFD does not get a chance to assert and adapt the relay to secure mode. However, in rare applications that use CTs with a K_{TOT} between 2 and 4, the 87AP element should be blocked when 87EFD

asserts, since no secure mode radius and angle settings can be applied to guarantee secure operation for all possible external faults.

An example simulated misoperation showing the security limits of the 87AP relay applied at a dual-breaker terminal is shown in Fig. 9. The K_{TOT} for the saturated CTs is 3, and the system X/R ratio is 100. The 87AP element is set with a secure radius of 6 and an angle of 120 degrees, significantly lower than what is expected based on the values shown in Fig. 8. In Fig. 9, 87EFD asserts even though CT saturation occurs within 4 milliseconds, but the secure mode settings are not sufficient to prevent a transient misoperation of the 87AP element.

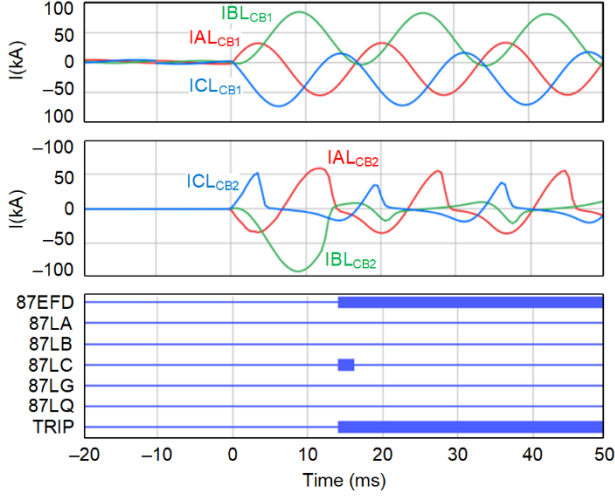

Fig. 9. Transient 87AP element misoperation case with heavy CT saturation

B. Settings Guidelines

The 87AP element is set by considering the various sources of errors, which are summarized in Table III for sensitive mode (when $87EFD = 0$) and Table IV for secure mode (when $87EFD = 1$). For secure mode, CT saturation is a major contributor of errors. Based on field experience, line CTs are typically dimensioned better than a K_{TOT} of 6. A challenging application example that supports this claim is shared in Section V.A.

TABLE III
SENSITIVE 87L SETTINGS GUIDELINES

Setting	87LP	87LG	87LQ
Pickup	0.30 pu	0.20 pu	1.25 pu ^C
Radius	1.35	1.35	1.35
Angle	90 degrees ^A	90 degrees ^A	90 degrees ^A

TABLE IV
SECURE 87L SETTINGS GUIDELINES

Setting	87LP	87LG	87LQ
Pickup	0.75 pu	0.30 pu	1.63 pu ^C
Radius	5.00 ^B	5.00 ^B	5.00 ^B
Angle	170 degrees ^{A,B}	170 degrees ^{A,B}	170 degrees ^{A,B}

^A Adjust based on worst-case channel asymmetry (Section IV.B).

^B Adjust from a K_{TOT} of 6 based on CT sizing guidelines (Fig. 8).

^C Adjust based on IBR rating and system parameters (Section IV.B).

For the 87LQ element, the sensitive pickup is set based on (2), which uses the MVA rating of the IBR (S_{IBR}), the voltage level of the line (V_{HV}), the CT ratio (CTR), the relay nominal secondary current (I_{NOM}), and a margin of 25 percent. The pickup is set based on similar principles from [2], in which the intent is to ignore the possibly poor negative-sequence current injected by the IBR.

$$87LQP_{SENS} = 1.25 \cdot \frac{S_{IBR}}{\sqrt{3} \cdot V_{HV} \cdot (CTR \cdot I_{NOM})} \text{ pu} \quad (2)$$

The secure pickup settings are based on the maximum current of the IBR, which can be 1.10 to 1.30 pu higher [2] and is represented by (3).

$$87LQP_{SECURE} = 1.30 \cdot 87LQP_{SENS} \text{ pu} \quad (3)$$

The minimum values of 0.20 pu and 0.30 pu for the sensitive and secure pickup settings, respectively, for the 87LQ and 87LG elements provide security for the steady-state CT and relay errors. The pickup for the 87LP element is set as follows:

- Sensitive—the steady-state CT and relay errors are in the order of 0.05 pu. Errors associated with charging current compensation or for short lines when uncompensated is typically less than 0.10 pu [19]. When adding a security margin for minor system transients, a value of 0.30 pu is adequate.
- Secure—additional considerations can raise this setting, such as significant transients associated with energization of the protected line [7] [8] and energization of a transformer or a reactor external to the differential zone [11]. A value of 0.75 pu is usually adequate.

The 87AP radius is set with the following considerations:

- Sensitive—mismatched relay and CT errors between the two terminals are assumed to be as large as 15 percent. When adding a security margin to get a total error of approximately 25 percent [11], the 87AP element radius is 1.35.
- Secure—CT saturation is the main source of error. Considering a K_{TOT} of 6, the associated radius based on Fig. 8 is 4. Adding a 25-percent margin for the other sources of errors, the radius is 5.

The 87AP angle is set with the following considerations:

- Sensitive—the main source of error is channel asymmetry, which is typically within 2 milliseconds [3]. Assuming a conservative 3.5-millisecond asymmetry for a 60 Hz system and an additional 15-degree margin, we calculate a value of 90 degrees, as shown in (1).
- Secure—CT saturation adds an angular error, and a value of 80 degrees is adequate for a K_{TOT} of 6. This results in an overall angle of 170 degrees for security. According to our simulations and field events of generator black-start and shunt reactor inrush [11], the angular error due to dc CT saturation when energizing a transformer or reactor external to the 87L zone typically does not exceed 25 degrees (or an 87AP

element angle setting of 50 degrees). Hence, the values shown in Fig. 8 provide adequate security.

For relays without an 87EFD [7], only the secure settings should be used. If the application parameters are better (i.e., CTs are sized larger than a K_{TOT} of 6 or the channel has a worst-case asymmetry lower than 3.5 milliseconds), the user may choose to use the default settings or use more dependable settings. If the application parameters are worse, more secure settings should be used.

C. Relay Design Improvements

An 87EFD assertion reducing dependability, as discussed in Section III.A, can occur in systems without IBRs as well. We have seen such a response in conventional generator, transformer, and bus applications [20]. A simple example is the case of a generator step-up transformer (GSU) with an open low-voltage generator circuit breaker (GCB) where the GSU presents a low-impedance zero-sequence path for an LG fault on the high-voltage side [21]. The example is shown in Fig. 10 for an AG fault on the line. Before the fault, due to the open GCB, there is no current; during the fault, pure zero-sequence current is seen at the GSU terminals with the A-, B-, and C-phase CTs measuring the same current. The A-phase current flows from both line terminals to the fault, and the 87L element sees the internal fault on the A-phase; the B-phase and C-phase 87L elements see the current flow through the unfaulted phases classifying it as an external fault, thereby asserting 87EFD.

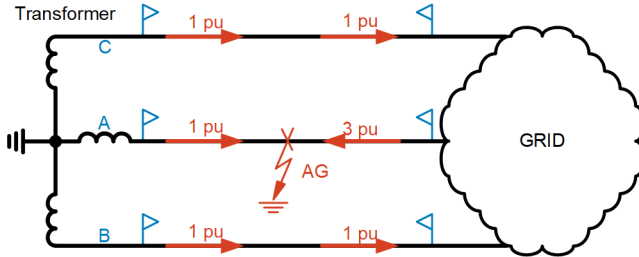

Fig. 10. Pure zero-sequence current seen at transformer terminals for AG fault

On differential relays that use only local measurements (e.g., generator, transformer, or bus relays), this scenario is not a problem since the relays have fully phase-segregated differential elements, including the external fault detector [10] [20] [21]. In other words, an external fault detector assertion in the B-phase or the C-phase does not reduce dependability in the A-phase.

In 87L relays, the design may be slightly different due to the requirement of a communications channel. To provide the most flexibility and to support channels with minimal bandwidth ($1 \cdot 64$ kbps) [22], the packet contains and transmits one 87EFD bit to the remote relay. Transmitting a single 87EFD bit adds security for an external fault behind a remote dual-breaker terminal [8], but it can reduce dependability of the other phases.

For 87L applications with conventional generation that is online, the change in unfaulted phase currents through the line is not significant enough where 87EFD asserts due to the significantly lower associated positive-sequence and negative-sequence impedances. However, in systems with IBRs, since

they are weak sources, the phenomenon is expected to occur more frequently, even when the IBR plant is online. Designing the 87L element so that the 87EFD is phase-segregated and only secures the associated phase differential element restores dependability. This requires communicating three bits, one for each phase, in the packet. This does not benefit the sequence differential elements (87LG and 87LQ), which can still lose dependability for an internal fault in these applications.

D. Improved Performance of 87L Relay

1) Dependability

The simulated event from Section III.A is played back to the relay with the settings from Table III and Table IV and with the default levels of channel asymmetry and CT saturation considered. Equations (2) and (3) are evaluated for the system with an IBR MVA rating (S_{IBR}) of 1,700 MVA, a voltage rating (V_{HV}) of 500 kV, and a CT ratio of 2000/5 ($CTR = 400$, $I_{NOM} = 5$ A). The resultant 87LQ sensitive and secure settings are 1.23 pu and 1.60 pu, respectively.

The relay event with the improved settings is shown in Fig. 11. Even though 87EFD asserts, the relay trips on 87LP, 87LG, and 87LQ. The 87LQ element has delayed assertion, which can happen due to the incoherent negative-sequence current injected by the IBR [1].

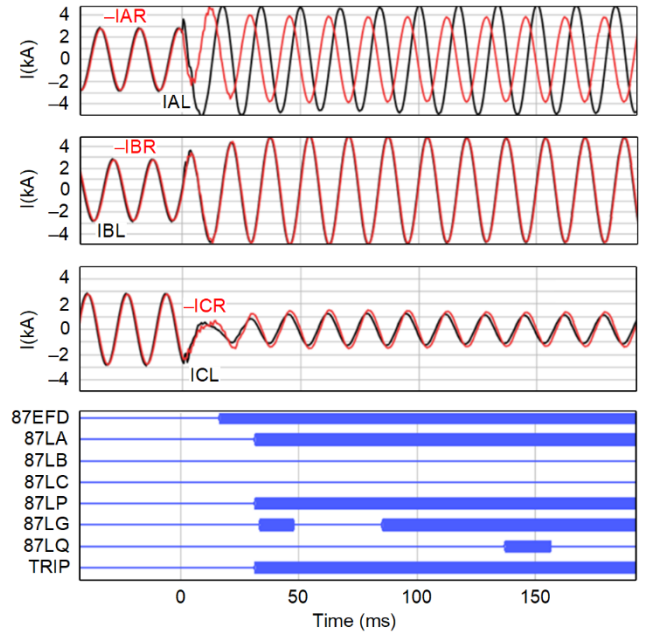

Fig. 11. Dependable operation of 87L elements despite 87EFD assertion

2) Security

For the field event of Section III.B where 87LQ misoperates, S_{IBR} is 184 MVA, V_{HV} is 138 kV, CTR is 400, and I_{NOM} is 5 A. Using (2) and (3), we calculate a sensitive and secure pickup of 0.48 pu and 0.63 pu, respectively. From Fig. 7, it is evident that a sensitive pickup setting of 0.48 pu can provide adequate security for this event.

E. Sensitivity Comparison Between 87AP and 87PCT

The relative sensitivities of the 87AP and 87PCT phase element (87LP) are evaluated by applying LG faults of various

resistances on a 230 kV, 50-kilometer line. The line has one weak terminal with a positive-sequence source-to-line impedance ratio (SIR_1) of 5 and a zero-sequence source-to-line impedance ratio (SIR_0) of 0.5 representing the IBR and the interconnection transformer. The other, strong terminal represents the grid and has an SIR_1 and SIR_0 of 1.

The 87AP element is set using the default sensitive settings of Table III, whereas 87PCT is set with an equivalent slope setting of 40 percent, according to Fig. 5. The sensitivity comparison of the 87AP and 87PCT phase elements at full load is shown in Fig. 12, including the reference pickup of 0.30 pu, assuming no assertion of the 87EFD. The 87LP pickup, which is common to both 87AP and 87PCT, is shown as reference. No channel asymmetry or CT saturation is modeled for this comparison, but the elements are set by considering the errors associated with the sensitive settings, as explained in Section IV.B.

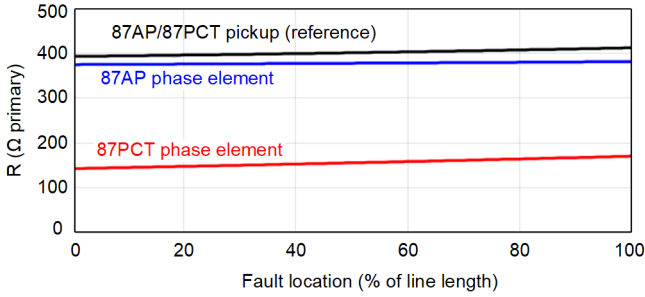

Fig. 12. 87AP and 87PCT phase element sensitivity comparison

It is evident from Fig. 12 that the 87AP element provides greater sensitivity. This is because the 87AP element can trip if either the current magnitude or angle between the two line terminals deviates (see Fig. 2 and Fig. 3). In these examples, the current magnitude is sufficiently different, allowing the 87AP element to provide greater sensitivity. In contrast, the relatively large slope of the 87PCT element makes no distinction between magnitude and angle deviations. Having only the slope setting to accommodate possibly large channel asymmetry limits 87PCT element sensitivity.

Modern communications are typically quite good; and for applications where the worst-case asymmetry is expected to be small, the 87AP and the 87PCT elements can be set sensitively to perform similarly, as shown in Fig. 13. Unlike 87PCT, the 87AP element sensitivity does not decrease significantly with channel asymmetry, because the ratio of the current magnitudes at the two line terminals during a fault is sufficiently different. Channels with small asymmetry promote sensitive settings, which benefit the applications described in Section V.B.

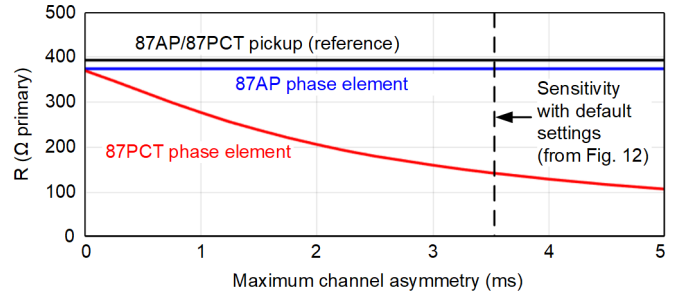

Fig. 13. Sensitivity comparison of 87AP and 87PCT phase element with equivalent settings for different levels of channel asymmetry

V. APPLICATION CONSIDERATIONS

A. CT Guidance Applied in an IBR System Example

The settings guidelines of Section IV.A associated with CT saturation are applied to a typical IBR tie-line example, shown in Fig. 14. A 138 kV, 20-kilometer tie line connects the IBR plant from the point of measurement (POM) to the three-breaker ring bus at the switching station labeled as the point of interconnection (POI). All CTs have a ratio of 200, an internal CT resistance (R_{CT}) of 0.5 ohm, and a burden (R_B) of 1 ohm.

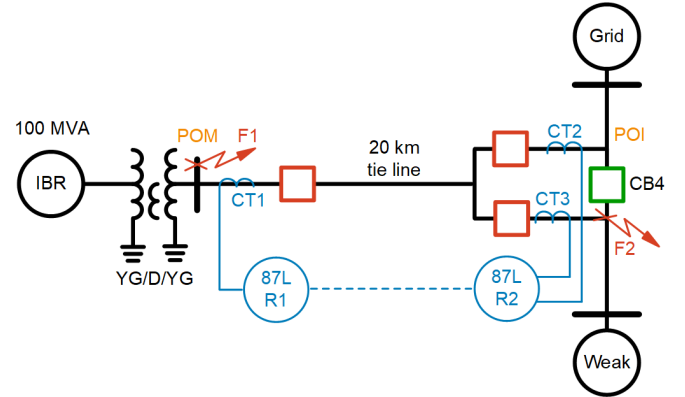

Fig. 14. Example of IBR plant connected to a three-ring breaker bus

Three-phase faults may occur at the location F1 and the location F2, and the scenarios are explained as follows.

- The maximum fault current seen by POM Relay R1, as measured by CT1, is for a fault at F1 where the grid contribution is 5 kA with an X/R of 10.
- The maximum fault current seen by POI Relay R2, as measured by CT2 and CT3, is for a fault at F2 with CB4 open and the contribution mostly from the system at 10 kA with an X/R of 20.

The K_{TOT} required by the relay to retain dependability in high-security mode is 4. The saturation voltage (V_{SAT}) of the CT may be calculated based on (4), with the values for CT1 and CT2/CT3 shown in (5) and (6), respectively.

$$V_{SAT} = K_{TOT} \cdot I_F \cdot (R_{CT} + R_B) \quad (4)$$

$$V_{SAT_CT1} = 4 \cdot \left(\frac{5,000 \text{ A}}{200} \right) \cdot (0.5 \Omega + 1 \Omega) = 150 \text{ V} \quad (5)$$

$$V_{SAT_CT23} = 4 \cdot \left(\frac{10,000 \text{ A}}{200} \right) \cdot (0.5 \Omega + 1 \Omega) = 300 \text{ V} \quad (6)$$

The minimum V_{SAT} for CTs rated C100, C200, C400, and C800 with a 0.5-ohm R_{CT} is 150, 250, 450, and 850 V respectively [10]. For CT1, any of these CTs may be applied.

For CT2/CT3, since the worst-case V_{SAT} of the application is 300 V, the next highest CT class of C400 is preferable. The minimum K_{TOT} required by the relay is 2 (as discussed in Section IV.A), which is satisfied by a C100 CT; however, in such cases, it is expected that the 87EFD bit is applied to block the 87AP element instead of elevating it to secure mode.

If we assume that C400 CTs are used for this application, then the relay settings may be made more sensitive. For a C400 with a V_{SAT} of 450 V applied at both terminals, the effective K_{TOT} may be calculated as follows:

- CT1 has a K_{TOT} of $4 \cdot (450 \text{ V}/150 \text{ V}) = 4 \cdot 3 = 12$.
- CT2 and CT3 have a K_{TOT} of $4 \cdot (450 \text{ V}/300 \text{ V}) = 4 \cdot 1.5 = 6$.

For this application, the worst-case X/R ratio is greater than 15 and the worst-case K_{TOT} is 6. To accommodate worst-case CT saturation, we obtain a radius setting of 4 and angle setting of 80 degrees from Fig. 8 using the blue line representing X/R = 100. With a 25-percent margin for the radius and 90 degrees for angular errors due to channel asymmetry including a margin (as discussed in Section IV.B), the radius is 5 and the angle is 170 degrees.

If C800 CTs are applied at the dual-breaker POI terminal, the effective K_{TOT} is 11.33. In that case, a secure mode radius of 4.6 and an angle of 150 degrees can be applied. It is evident from this example that CTs at the dual-breaker terminals have higher requirements than single-breaker terminals, because the worst-case external fault current and the associated X/R ratio is not reduced by the line impedance. For this example, we use three-phase faults, but a similar calculation applies to ground faults. IEC CT sizing and relay settings can be done in a similar manner [10].

If the system fault current levels are lower due to higher penetration of IBRs or for a weaker grid, the element can be set more sensitively.

B. Application Dependability Improvements

The dependability improvements explained in this paper benefit many applications considerably, including the following:

- Systems with IBRs—as explained in Section III.A, it is possible for the 87EFD to desensitize the 87L element in such applications.

- Series-compensated lines—current inversion in some systems is a possibility for an internal fault [23].
- Single-phase tripping applications—increased sensitivity from the 87LP element can improve phase selectivity for high-resistance faults in these applications.
- Scenarios with evolving external-to-internal faults—it is possible for 87L relays to have reduced dependability when a fault evolves from an external to an internal one due to the bigger secure mode restraint region.

The guidance may also be applied to other applications to add sensitivity while maintaining adequate security. Having an 87L channel provides numerous other advantages, including improved fault-type identification and fault location due to availability of currents from both line terminals. The relay may also use the low bandwidth (1 • 64 kbps) channel to provide double-ended traveling-wave fault location, which provides significantly higher accuracy than impedance-based fault location techniques [8].

VI. CONCLUSION

The 87L element is an excellent choice in systems with IBRs. When applied with conventional guidance, the 87L element may lose dependability for ground faults in systems with IBRs. This loss of dependability occurs when there is a significant change in unfaulted phase currents due to the low-impedance zero-sequence path presented by the IBR transformer, whereas the IBR acts as a weak positive-sequence and negative-sequence source. The 87LQ element may lose security due to the harmonic content and poor negative-sequence injected by the IBR, as we showed using a field event.

This paper presented solutions to improve 87L element dependability and security via improved application guidance and relay design improvements. The security improvement consists of desensitizing the 87LQ element based on the IBR ratings and basic system data. The dependability improvements are achieved by characterizing the two potential major sources of errors for the 87L element, namely channel asymmetry and CT saturation. The 87L element can also be designed to send additional data in the communication packet by using the higher bandwidth afforded by modern communications infrastructure. The added dependability significantly benefits applications in systems with IBRs, series-compensated lines with current inversion, systems using single-phase tripping, and evolving fault scenarios.

VII. ACKNOWLEDGEMENTS

The authors thank Aboutaleb Haddadi and Evangelos Farantatos of EPRI for sharing a simulated event used for this paper. The authors also thank Brian Smyth for sharing his experience supporting 87L relays.

VIII. REFERENCES

- [1] R. Chowdhury and N. Fischer, "Transmission Line Protection for Systems With Inverter-Based Resources – Part I: Problems," *IEEE Transactions on Power Delivery*, IEEE, Vol. 36, No. 4, August 2021, pp. 2,416–2,425.
- [2] R. Chowdhury and N. Fischer, "Transmission Line Protection for Systems With Inverter-Based Resources – Part II: Solutions," *IEEE Transactions on Power Delivery*, IEEE, Vol. 36, No. 4, August 2021, pp. 2,426–2,433.
- [3] IEEE Std C37.243-2015, *Guide for Application of Digital Line Current Differential Relays Using Digital Communication*.
- [4] D. Tziouvaras, H. Altuve, G. Benmouyal, and J. Roberts, "Line Differential Protection With an Enhanced Characteristic," proceedings of the 3rd Mediterranean Conference on Power Generation, Transmission, Distribution, and Energy Conversion, Athens, Greece, November 2002.
- [5] C. Henville and R. Chowdhury, "Coordination of Resistive Reach of Phase and Ground Distance Elements," proceedings of the 48th Annual Western Protective Relay Conference, Spokane, WA, October 2021.
- [6] D. Miller, "Three Phase Bus Fault With Fault Impedance," proceedings of the 42nd Annual Western Protective Relaying Conference, Spokane, WA, October 2015.
- [7] SEL-311L Line Current Differential Protection and Automation System Instruction Manual. Available: selinc.com.
- [8] SEL-411L Advanced Line Differential Protection, Automation, and Control System Instruction Manual. Available: selinc.com.
- [9] B. Kasztenny and D. Finney, "Generator Protection and CT Saturation Problems and Solutions," proceedings of the 58th Annual Conference for Protective Relay Engineers, College Station, TX, April 2005.
- [10] R. Chowdhury, D. Finney, N. Fischer, and D. Taylor, "Determining CT Requirements for Generator and Transformer Protective Relays," proceedings of the 46th Annual Western Protective Relay Conference, Spokane, WA, October 2019.
- [11] R. Chowdhury, N. Fischer, D. Taylor, D. Caverly, and A. B. Dehkordi, "A Fresh Look at Practical Shunt Reactor Protection," proceedings of the 49th Annual Western Protective Relay Conference, Spokane, WA, October 2022.
- [12] G. Benmouyal and T. Lee, "Securing Sequence-Current Differential Elements," proceedings of the 31st Annual Western Protective Relay Conference, Spokane, WA, October 2004, pp. 23–25.
- [13] A. Haddadi, E. Farantatos, I. Kocar, and U. Karaagac, "Impact of Inverter Based Resources on System Protection," *Energies*, Vol. 14, No. 4, February 2021, p. 1,050.
- [14] R. M. Moreno, J. A. Pomilio, L. C. Pereira da Silva, and S. P. Pimentel, "Mitigation of Harmonic Distortion by Power Electronic Interface Connecting Distributed Generation Sources to a Weak Grid," Brazilian Power Electronics Conference, Bonito-Mato Grosso do Sul, Brazil, October 2009, pp. 41–48.
- [15] J. Gahan, A. Valdez, B. Cockerham, R. Chowdhury, and J. Town, "Field Experience With Open-Phase Testing at Sites With Inverter-Based Resources," proceedings of the 74th Annual Conference for Protective Relay Engineers, Virtual Format, March 2021.
- [16] IEC Std 60255-187-1-2021, *Measuring Relays and Protection Equipment – Part 187-1: Functional Requirements for Differential Protection – Restrained and Unrestrained Differential Protection of Motors, Generators, and Transformers*.
- [17] IEEE Std C57.13-2016, *IEEE Standard Requirements for Instrument Transformers*, 2016, p. 38.
- [18] IEC TR 61869-100:2017, *Instrument Transformers – Part 100: Guidance for Application of Current Transformers in Power System Protection*.
- [19] A. Hargrave and G. Smelich, "Setting and Testing Line Charging Current Compensation in the SEL-411L Relay," SEL Application Guide (AG2018-02), 2018. Available: selinc.com.
- [20] A. B. Dehkordi, R. Chowdhury, N. Fischer, and D. Finney, "Generator Protection Validation Testing Using a Real-Time Digital Simulator: Stator Winding Protection," proceedings of the 48th Annual Western Protective Relaying Conference, Spokane, WA, October 2021.
- [21] R. Cole, R. Tuck, T. Solinsky, C. Sun, R. Chowdhury, A. Abd-Elkader, and B. Matta, "Bus Differential Protection Upgrade for a 1,500 MVA Nuclear Plant With Atypical Connections," proceedings of the 75th Annual Conference for Protective Relay Engineers, College Station, TX, March 2022.
- [22] IEEE Std C37.94-2017, *IEEE Standard for N Times 64 kbps Optical Fiber Interfaces Between Teleprotection and Multiplexer Equipment*.
- [23] E. Bakie, C. Westhoff, N. Fischer, and J. Bell, "Voltage and Current Inversion Challenges When Protecting Series-Compensated Lines – A Case Study," proceedings of the 42nd Annual Western Protective Relay Conference, Spokane, WA, October 2015.

IX. BIOGRAPHIES

Ritwik Chowdhury received his BS degree in engineering from the University of British Columbia and his MS degree in engineering from the University of Toronto. He joined Schweitzer Engineering Laboratories, Inc. (SEL) in 2012, where he is presently a senior engineer in research and development. Ritwik holds 9 patents and has helped author 25 technical papers. He was recognized as an exceptional reviewer for IEEE Transactions on Power Delivery for 2019 and 2021. He is the vice chair of the Protection and Control Practices Subcommittee (I-SC) of the IEEE PSRC Committee, the chair of two IEEE Standards Working Groups, and the recipient of the 2021 PSRC Outstanding Young Engineer Award. Ritwik is a senior member of the IEEE and a registered professional engineer in the province of Ontario.

Ryan McDaniel earned his BS in computer engineering from Ohio Northern University in 2002. In 1999, he was hired by American Electric Power (AEP) where he worked as a relay technician and a protection and control engineer. In 2005, he joined Schweitzer Engineering Laboratories, Inc. (SEL) and is currently a principal engineer. His responsibilities include providing application support and technical training for protective relay users. Ryan is a registered professional engineer in the state of Illinois and a member of the IEEE.

Normann Fischer received a Higher Diploma in Technology, with honors, from Technikon Witwatersrand, Johannesburg, South Africa, in 1988; a BSEE, with honors, from the University of Cape Town in 1993; an MSEE from the University of Idaho in 2005; and a PhD from the University of Idaho in 2014. He joined Eskom as a protection technician in 1984 and was a senior design engineer in the Eskom protection design department for three years. He then joined IST Energy as a senior design engineer in 1996. In 1999, Normann joined Schweitzer Engineering Laboratories, Inc., (SEL) where he is currently a distinguished engineer in research and development. He was a registered professional engineer in South Africa and a member of the South African Institute of Electrical Engineers. He is currently a senior member of IEEE and a member of the American Society for Engineering Education (ASEE). Normann has authored over 60 technical and 10 transaction papers and holds over 20 patents related to electrical engineering and power system protection.