

Coordination of Resistive Reach of Phase and Ground Distance Elements

Presented to
Western Protective Relay Conference, October 2021
Spokane, Washington, USA

Authored by
Charles Henville, Henville Consulting Inc.
And
Ritwik Chowdhury, Schweitzer Engineering Laboratories Inc.

Abstract— This paper discusses the issue of coordination of resistive reach of phase and ground distance elements used for transmission line protection. It addresses the considerations and benefits of coordinating this aspect of distance elements considering possible fault resistance.

This page intentionally blank

Coordination of Resistive Reach of Phase and Ground Distance Elements

1. Introduction

This paper investigates issues associated with coordinating resistive reaches of phase and ground distance elements used for transmission line protection systems. These issues may be important if there is significant resistance in the fault. Distance elements are most often used for high voltage (HV) and extra high voltage (EHV) transmission lines, so the significance of fault resistance at these voltages will be the focus of the discussion. In the case of multiphase faults, arc resistance is the main component of fault resistance. In the case of ground faults, other factors such as tower footing resistance, presence or absence of shield wires, and tree resistance may also affect the fault resistance. Responses of both mho and quadrilateral distance elements to resistive faults will be considered. Both communications independent and directional comparison communications-assisted tripping schemes may be adversely affected by fault resistance (depending on the responses of various distance elements). The investigation uses a tool that models faulted power systems and the responses of protection relays¹.

The intent is to highlight the fact that the fault resistance may be sufficiently large in some cases to elicit different responses of relays on different lines, or on different terminals of the same line. Such different responses may adversely affect the security of transmission line protection systems. Consideration of fault resistance may improve protection system security by preventing overtripping for faults outside the protected zone.

2. Background

Distance relays are commonly applied to protect transmission lines. One of the important properties of such relays is that they take advantage of the fact that line short circuits with low resistance present mostly an inductive impedance to protection systems at the line terminal. The impedance of overhead air insulated HV transmission lines is much more reactive than resistive, so the reactive reach of a distance relay is a key factor in setting it. When setting these relays, it is normal practice to check and consider coordination of reactive reaches. A forward-looking overreaching zone should not reach past a faster zone beyond the remote terminal. For instance, a time-delayed Zone 2 should not reach past any instantaneous Zone 1 protecting remote lines or equipment. In some cases, with a short line following a long line, it may not be possible to set the Zone 2 reach with sufficient dependability without overreaching the remote Zone 1. In such cases, increasing the Zone 2 time-delay to coordinate with the remote Zone 2 is often done.

In some cases, particularly for ground fault protection, it is recognized that fault resistance may be significant and require special consideration. In these cases, sensitivity to resistive ground faults may be checked to ensure dependability. North American distance relay applications have historically been more often mho functions than quadrilateral. Before the advent of multifunction line digital protection systems, discrete phase distance relays with mho characteristics have often been applied in conjunction with directional time and instantaneous ground overcurrent relays.

Multifunction line protection systems now make the application of ground distance functions common. Quadrilateral functions are often applied, particularly for ground distance protection [1, 2]. For multiphase faults, fault resistance is not considered as frequently because the arc resistance is

¹ ASPEN OneLiner, V 15.3

usually small compared to the line reactance. However, in applications to short lines, quadrilateral phase distance elements may also be applied for improved sensitivity to resistive faults.

This paper is primarily focused on coordination of step-distance schemes. Some of the issues may also affect systems with single or redundant pilot protection schemes and are discussed in Section 8.2.

In this paper, we refer to primary and backup protection systems as applied to step-distance schemes. Although these terms are generally well understood, to avoid any misunderstandings, the terms are defined here as used in this paper. The primary protection system is closest to the fault on a line and is expected to clear the fault before any more distant protection systems operate. There will be at least one primary protection system at each terminal of a transmission line, and there will often also be redundant primary protections. Backup protection is any other (than primary) protection that might operate after a time delay for fault on a line. Note that backup protection is not the same as redundant primary protection. Also note that in transmission systems, backup protection does not necessarily have to operate for all faults on a line protected by its own primary protections. Figure 1 shows examples of primary and backup protections.

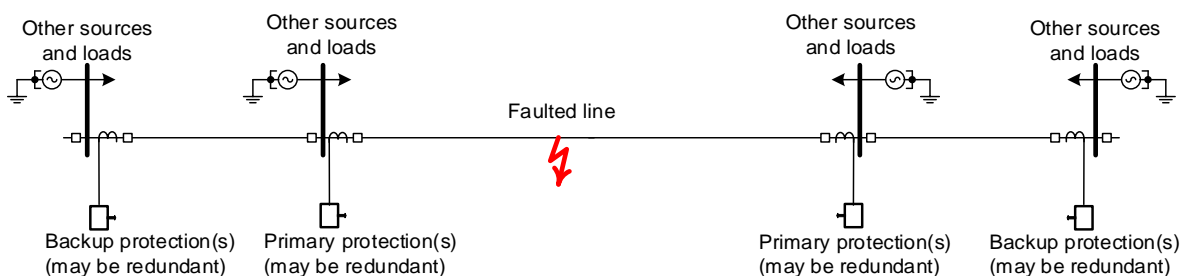

Figure 1 Example primary and backup protections

As a general rule, for good selectivity, primary protection systems should always be faster than backup protections, and if possible, more sensitive. In the case of simple overcurrent relays, the angle of the apparent impedance due to the fault is usually not important. Full coordination can be checked considering only current magnitude and time delay. However, in the case of quadrilateral distance elements, separate measurements are made for resistive and reactive blinders. Although coordination of reactive reach for bolted faults is normally checked, coordination of resistive reach is not necessarily always checked. Further, in the case of mho distance elements, resistive and reactive reach cannot be independently adjusted, and coordination for resistive faults has not historically been always checked.

See for example Figure 2, which shows the resistive and reactive reach margins of a primary and backup relay pair of quadrilateral distance relays. The primary relay Zone 1 reactive blinder reaches further than the backup relay Zone 2 reactive blinder. However, the primary relay Zone 1 resistive blinder does not reach as far as the backup relay Zone 2 resistive blinder. Of course, infeed current that the primary relay measures, but the backup relay does not, will decrease the relative sensitivity of the backup relay. However, without studying the resistive reaches, whether the backup relay coordinates with the primary relay or what the coordination margins are, may not be known.

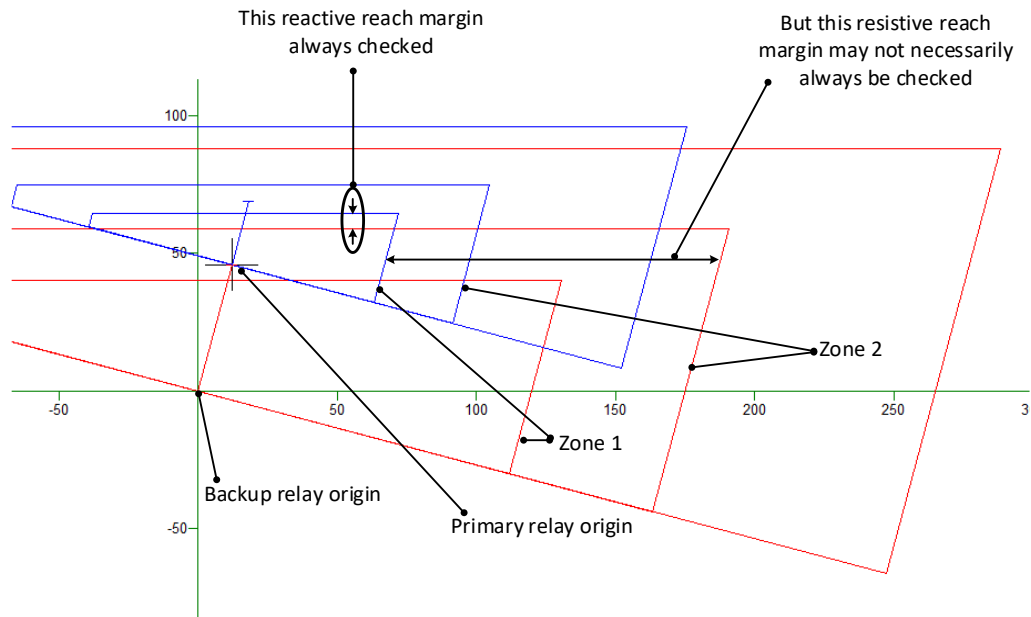

Figure 2 Coordination margins between a primary and backup relay pair

3. Fault Resistance

3.1. Phase Faults

Fault resistances for multiphase faults are often not considered to be significant on high voltage systems. The most significant component of fault resistance for multiphase faults is arc resistance. Arc resistance will increase with length. As noted in [3], the arc length can increase at a rate of 33 meters per second. Extension may be caused from the magnetic forces associated with the arc, convection of the plasma, or wind and other environmental factors. Multiphase fault clearing times are usually less than one second for HV systems, and the opportunity for arc length extension is very limited. However, in some cases, slow fault clearing time may result in significant arc extension and associated arc resistance.

As reported in [4], the arc extension of a three-phase 138 kV fault temporarily moved the impedance outside the characteristic of an overreaching Zone 2 relay on one side causing delayed clearing (43 cycles instead of 23 cycles) from that side. It was unexpectedly (but desirably) cleared from the other side by ground overcurrent protection responding to unbalanced fault resistances due to different arc lengths between the three phases.

In another case reported in Appendix A of this paper, a breaker failed to interrupt a three-phase fault on a 138 kV line. Over a few seconds, the arc extended to such an extent that a backup mho distance relay with a time delay of 2.8 seconds was unable to detect and clear the fault. The fault persisted for more than 10 seconds, and eventually cleared itself.

From these examples, it can be seen that (due to arc extension) there is a possibility, although infrequent, of high fault resistance for multiphase faults if the protection delay is too long.

3.2. Ground Faults

In the case of single-line-to-ground (1LG) faults, there is often a greater chance of faults with significant resistance. Some of the causes of fault resistance are (i) arc resistance, (ii) tower footing resistance, (iii) tree resistances, and (iv) other hazards such as cranes and booms.

Because of this, many utilities have criteria that their transmission line protection has to be dependable for 1LG faults with higher resistance than for multiphase faults [5]. For flashover to a tower, the arc resistance may be very small, similar to the case with multiphase faults. However, if the tripping time is extended, there is a possibility of high arc resistance just as in the case of multiphase faults. Tower footing resistance requirements are significantly affected by the presence (or absence) of lightning shield wires. Where these wires are applied, as is often the case, the tower footing resistance is designed and constructed to be less than about 10 ohms [5] to prevent a backflash from the tower to the phase conductor. In some cases, where the cost of keeping the footing resistance low is too great, or where the lightning frequency is low, some utilities may elect to eliminate the shield wire and associated tower footing grounding to reduce transmission line costs. In such cases, tower footing resistance may be several hundred ohms [6]. Figure 3 shows an example of the aftermath of a 1LG fault with tower footing resistance of approximately 200 ohms on an unshielded line that persisted for several tens of minutes, resulting in significant hazard.



Figure 3 Aftermath of a 200-ohm 138 kV line 1LG fault

Even with low tower footing resistance, there is a possibility of flashover of a line to a tall object such as a crane or tree that may result in a 1LG fault resistance much larger than 10 ohms. Figure 4 shows a tree that suffered a flashover from a 230 kV line. The tree presented such a high resistance that a quadrilateral distance relay set to cover 200 ohms primary resistance was not able to sense the fault. The fault was eventually cleared by ground time overcurrent protection.



Figure 4 Tree burned by flashover from 230 kV

To provide dependable protection for 1LG faults that present a resistance too high to be sensed by distance protection, many utilities apply ground overcurrent protection to their transmission lines as supplementary protection [5]. It should be noted that basic ground overcurrent protection makes faulted phase selection more complicated in single phase tripping schemes. However, if 1LG faults with high resistance beyond the sensitivity of ground distance relays are rare, it may be acceptable to trip all three phases on ground overcurrent relaying for such faults even when single phase tripping and reclosing is applied.

4. Resistive reach of quadrilateral elements

Quadrilateral elements have individually configurable reaches for reactance and resistance elements. In modern relays, the resistive reach settings of each zone are usually independent of each other. The system of Figure 5 will be used to show some of the issues associated with coordination of a primary relay at the MID terminal of TL1, and a backup relay at the SRC terminal of TL2. In the modeled system, the nominal voltage is 138 kV, TL1 is identical to TL2. Positive-, negative-, and zero-sequence infeed sources may or may not be present at MID. The positive-sequence voltage angle of the source at REMOTE may be adjusted to cause a variable amount of pre-fault power flow.

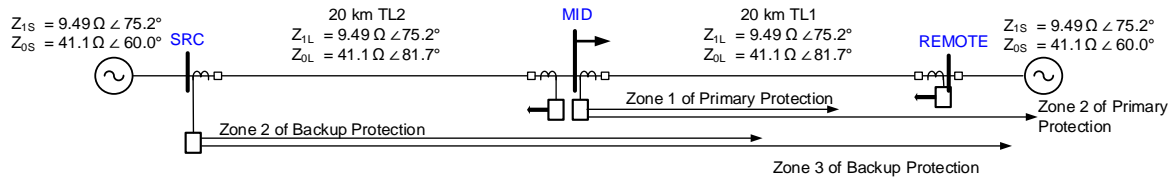

Figure 5 Example 138 kV system used to show coordination issues

In the following cases, faults are simulated on TL1, and the responses of primary and backup relays are observed. Different fault locations are simulated and the responses of relays from different manufacturers (identified as “MFR”) are shown. In this paper, three different manufacturer products are investigated, “MFR A”, “MFR B”, and “MFR C”.

In the power system, there is always load at MID; so, it is desirable that TL2 remains in service for any fault on TL1. Note that infeed at Bus MID is an important factor that affects relative reaches of primary and backup relays. This is not discussed in this section but explored in Section 6.

4.1. Case 1 – Simple case using identical primary and backup relays with no infeed at MID

Figure 6 shows the simulated response of primary and backup relays to a resistive 1LG fault close in to MID on TL1. For this simple case the system has been modeled as radial, with no load, and no infeed at MID, and the breaker open at the TL1 REMOTE terminal. It can be seen that for the simulated fault on TL1, the TL1 Zone 1 element trips instantaneously, and the backup TL2 relay Zone 2 element does not trip. This illustrates the apparent resistive reach margin between TL1 Zone 1 and TL2 Zone 2 elements on the RX diagram, and is matched by the responses of both relays.

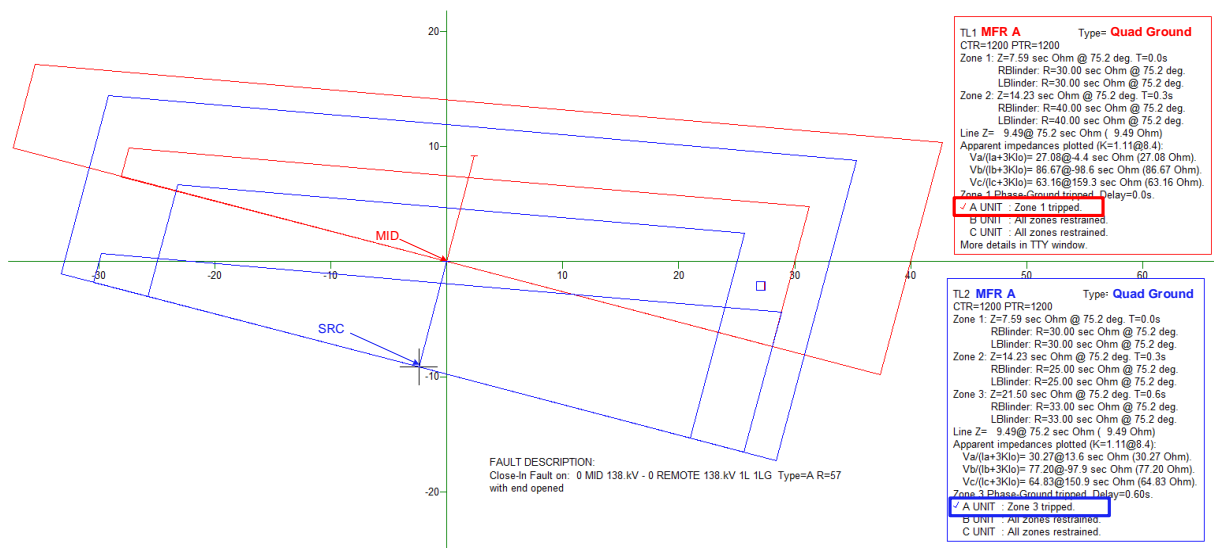

Figure 6 - Simple case, with identical relays at MID terminal of TL1 and SRC terminal of TL2

Note that in Figure 6, axes impedances are scaled in primary ohms and relay settings are in secondary ohms. The CT and VT ratios have both been chosen to be 1200 so that ohmic values of primary and secondary impedances are the same as each other. Note that the fault resistance is simulated as being 57Ω close into the MID terminal. One may expect the apparent impedance seen by TL1 relay to be at $57\Omega \angle 0^\circ$. However, the plot shows an apparent impedance of $27.08\Omega \angle -4.4^\circ$ with respect to the origin (MID) of TL1 relay. This is because the fault impedance is converted on the plot to an apparent impedance using Equation (1).

$$Z_{APP} = \frac{Z_F}{(1+k_0)} \quad (1)$$

Where Z_{APP} is the apparent impedance, Z_F is the fault impedance, and k_0 is the zero-sequence current compensation factor. k_0 is given by Equation (2).

$$k_0 = \frac{1}{3} \left(\frac{Z_0}{Z_1} - 1 \right) \quad (2)$$

Where Z_0 and Z_1 and the line zero- and positive-sequence impedances respectively. In this case, the value of k_0 is $1.11 \angle 8.4^\circ$. Therefore, with respect to the TL1 relay:

$$Z_{APP} = \frac{57 \Omega}{(1 + 1.11 \angle 8.4^\circ)} = 27.08 \angle -4.4^\circ \quad (3)$$

4.2. Case 2 – Differences in implementing resistance blinder

For Case 2, another manufacturer’s relay is added to TL1, and Case 1 simulated again. The responses of both TL1 relays and the response of the backup relay of Case 2 are shown in Figure 7. In this case, everything is identical to Case 1 except for the addition of a third relay. The third relay is identified as type “MFR B” to indicate a different manufacturer of relay (from type “MFR A”). Figure 7 shows that the TL1 MFR B relay has the same settings as TL1 MFR A relay, but their responses are different. The MFR A relay trips instantaneously by the Zone 1 function, but the MFR B does not trip at all. Therefore, although the RX diagram shows that the MFR B relay should operate faster than the backup MFR A relay, in fact, it does not. This is because the MFR B relay uses an operating principle that measures the actual fault impedance, Z_F ($57\Omega \angle 0^\circ$) and not the smaller, apparent fault resistance Z_{APP} ($27.08\Omega \angle -4.4^\circ$) from Equation (1). The 57Ω resistance measured by the MFR B relay is outside even its Zone 2 resistive reach setting of 40Ω .

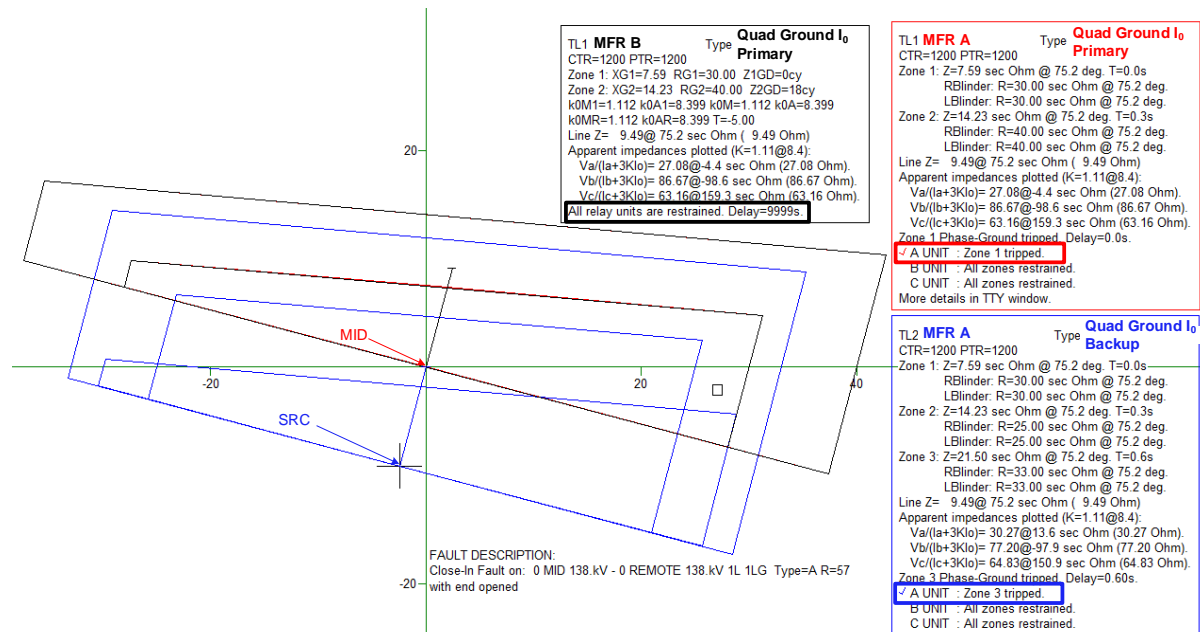

Figure 7 - Case 2, like Case 1, but with a different type of relay added to MID terminal of TL1

This case illustrates the importance of considering the measuring principle of the resistive blinder when checking coordination instead of simply relying on plots of characteristics on the RX diagram.

4.3. Case 3 – Impact of reactance element tilt

Resistive faults can also result in a mis-coordination of the reactance element. The reactance element for Zone 1, given it is an underreaching zone, is typically biased toward security and set with a negative tilt as shown in Figure 8. On the other hand, the overreaching Zone 2 of the backup relay is typically biased towards dependability and may be set with a flat or a positive tilt. Some manufacturers allow only Zone 1 to have a negative tilt.

A 25Ω fault was simulated at 50% of TL1 with the REMOTE terminal breaker open for the case shown in Figure 8. Zone 2 of primary and backup relays, both from the same manufacturer and of the same type, operate at the same time resulting in a miscoordination.

To coordinate backup relay Zone 2 with primary relay Zone 1, a secure practice is to ensure they both have the same tilt. Alternatively, if the backup Zone 2 is not able to be tilted and the primary Zone 1 is tilted downwards, it may be desirable to reduce the backup relay’s reactive reach to mitigate a possible miscoordination as shown in Figure 8.

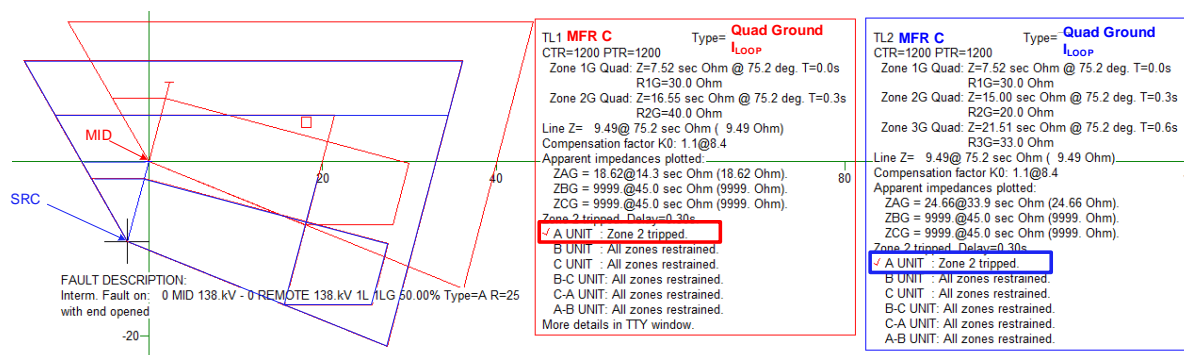

Figure 8 Zone 2 of the primary and backup relays operate simultaneously due to inconsistent tilt

Note that this MFR C relay is polarized by loop current (clarified in Section 4.4) and has been set with a larger downward tilt (than MFR A or MFR B relays) on the Zone 1 reactive reach blinder to increase its security during high load flow.

4.4. Case 4 – Polarizing considerations

As has been discussed in several references [1,2,7,8], distance relays commonly use phase comparators to define the thresholds of various elements. The two inputs to the comparators are the operating signal and the polarizing signal. The signals may be obtained from the derived positive-, negative-, and zero-sequence components of the fault quantities, or directly from the voltages and currents present during the fault. Several voltage and current loops are measured during a fault as listed in Table I.

Table I: Loop Voltage and Loop Current associated with the different distance element loops

Distance Loop	Loop Voltage	Loop Current
AG	V_A	$I_A + k_0 \cdot 3I_0$
BG	V_B	$I_B + k_0 \cdot 3I_0$
CG	V_C	$I_C + k_0 \cdot 3I_0$
AB	$V_A - V_B$	$I_A - I_B$
BC	$V_B - V_C$	$I_B - I_C$
CA	$V_C - V_A$	$I_C - I_A$

The use of different polarizing signals can impact coordination. Relay manufacturers use different polarizing currents [7] to improve the quadrilateral element performance for resistive faults, such as:

1. Self-polarized quadrilateral element – Uses loop current (shown in Table I) as the polarizing signal, which is affected by load flow, but is dependable for balanced three-phase faults. Can provide dependability in single-phase tripping applications during the one phase open interval.
2. Zero-sequence current – Benefits from strong zero-sequence paths presented by nearby power transformers, polarizing signal unaffected by load, and dependable for ground faults.
3. Negative-sequence current – Typically is the most homogenous network, polarizing signal unaffected by load or zero-sequence mutual coupling, and dependable for unbalanced faults.

A possible effect of using different polarizing currents is shown in Figure 9. The source at the REMOTE bus is in service and positive-sequence voltage lags the voltage source at the SRC bus by 30 degrees. This means there is heavy load flow from SRC to REMOTE. The zero-sequence source impedance angle is also lower than the rest of the system (refer to Figure 5). The primary relay uses zero-sequence current polarization whereas the backup relay uses negative-sequence current polarization, both provided by manufacturer A with a single setting change.

For a 20Ω fault at 50% of TL1, Zone 2 of both primary and backup relays operate showing the mis-coordination. A more secure approach is to use the same polarizing option to coordinate primary and backup protection.

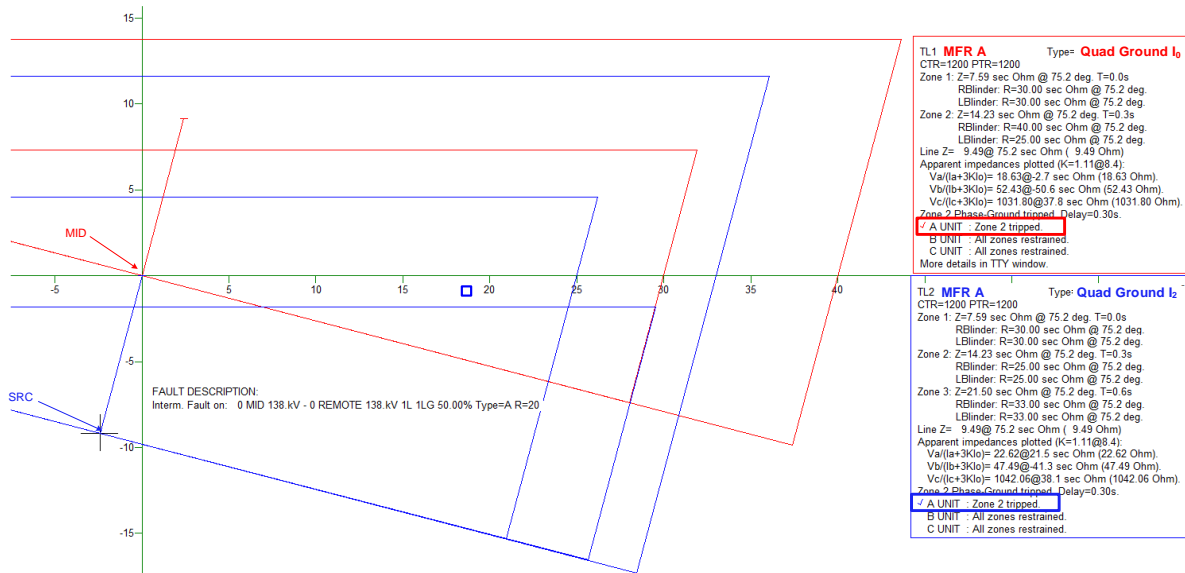

Figure 9 Zone 2 of the primary and backup relays operate at the same time due to use of different polarizing currents

5. Resistive reach of mho elements

Mho elements have one reach setting that determines both the reactive and resistive coverage. To address various application challenges, different manufacturers use different choices for the polarizing voltage [8]:

- Self-polarized – Uses loop voltage (Table I), unreliable for close-in bolted faults when the voltage is very small, or zero.
- Cross-polarized – Uses voltages from un-faulted phases, unreliable for close-in bolted three-phase faults when all voltages are very small, or zero.
- Positive-sequence voltage – Uses voltages from all phases to improve single-phase trip security during open interval. Unreliable for close-in bolted three-phase faults when all voltages are very small, or zero.
- Positive-sequence memory voltage – Uses a portion of the pre-fault and faulted positive-sequence voltage to improve single-phase trip security during open interval, reliability for close-in bolted three-phase faults, and performance in series compensated lines.

Implementation differences between different relay manufacturers can also make a difference when checking coordination for resistive faults. The tool used to demonstrate the characteristics only shows the self-polarized mho characteristic on the RX diagram. However, the response of the relay as shown in the caption boxes incorporates the polarization method used by the relay.

The performance of the MFR C mho element for the system of Figure 5 is shown in Figure 10. Zone 1 is set to 80% of line impedance and the backup Zone 2 is set to 150% of the line impedance. For a 6Ω 1LG fault, the primary relay does not trip, whereas the backup relay Zone 2 trips after a time delay resulting in a miscoordination.

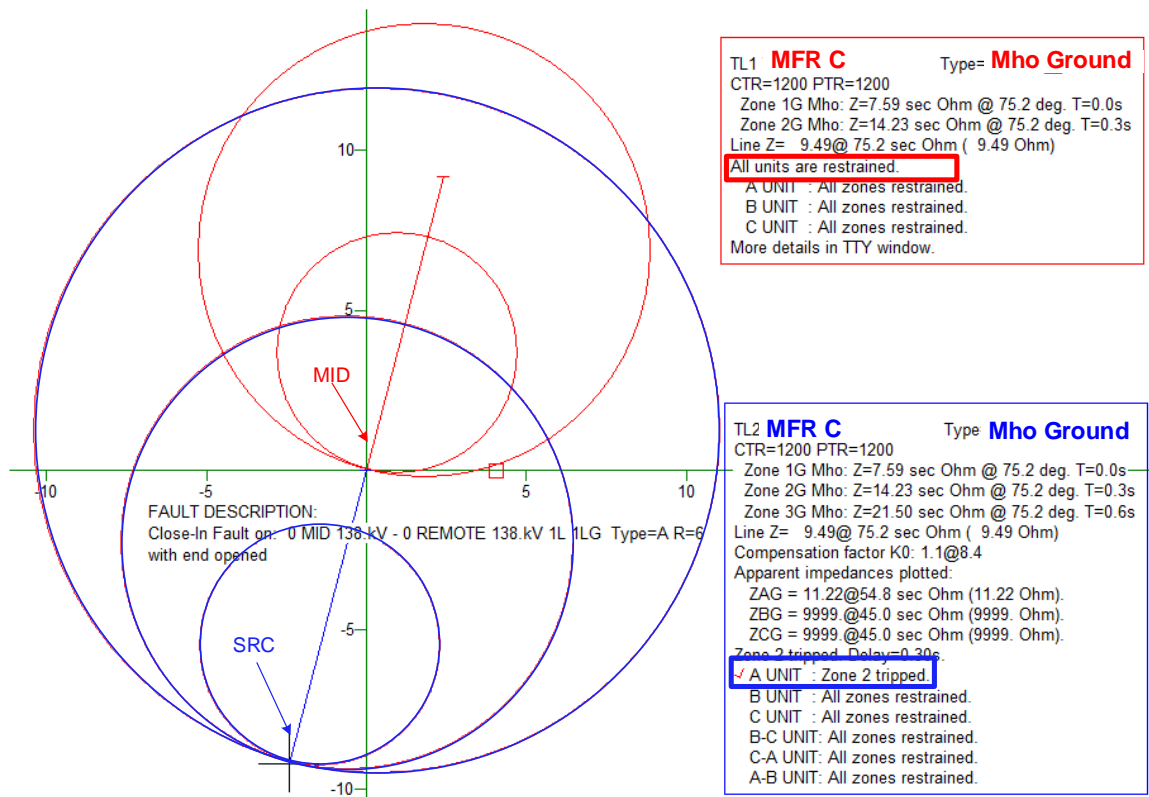

Figure 10 Primary relay does not trip whereas backup relay trips for a 6 Ω 1LG fault

In contrast, the expansion from the MFR A mho element reveals desirable coordination as shown via the 17 Ω fault in Figure 11 where Zone 1 of the primary relay operates, and the backup relay does not. A lower fault resistance would allow Zone 2 of the backup relay to operate. A higher fault resistance would be detected by Zone 2 of the primary relay without any operation from the backup relay.

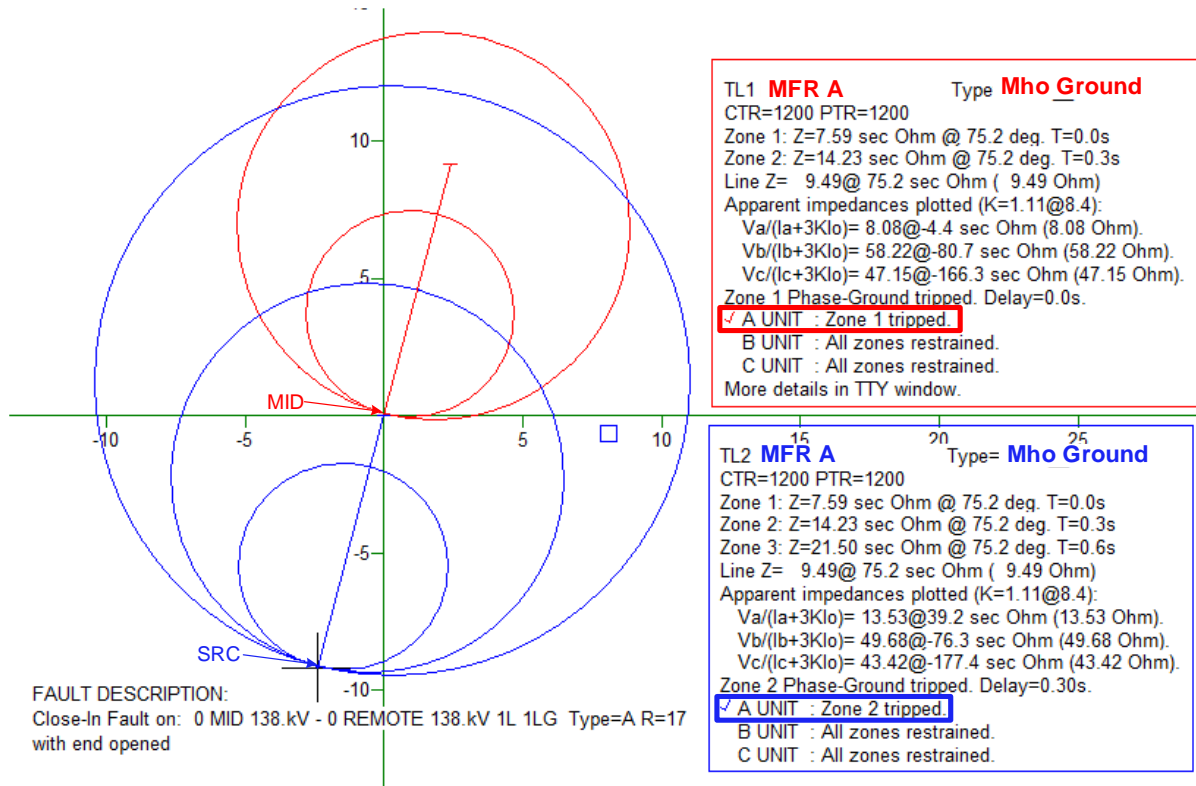

Figure 11 Backup relay coordinates well with Primary relay

The coordination of mho ground relays was explored further by checking a modified system where TL1 was reduced in length and impedance to a value of half that shown in Figure 5. The TL1 MFR A relay reach settings were adjusted accordingly. The results are shown in Figure 12. It can be seen from this figure that when the primary protection reach is shortened, there could be a risk of miscoordination, even for MFR A relays.

Figure 12 shows that for a close-in 1LG fault with 11 ohms of fault resistance, the primary relay MFR A operates in Zone 2 time simultaneously with the backup relay Zone 2.

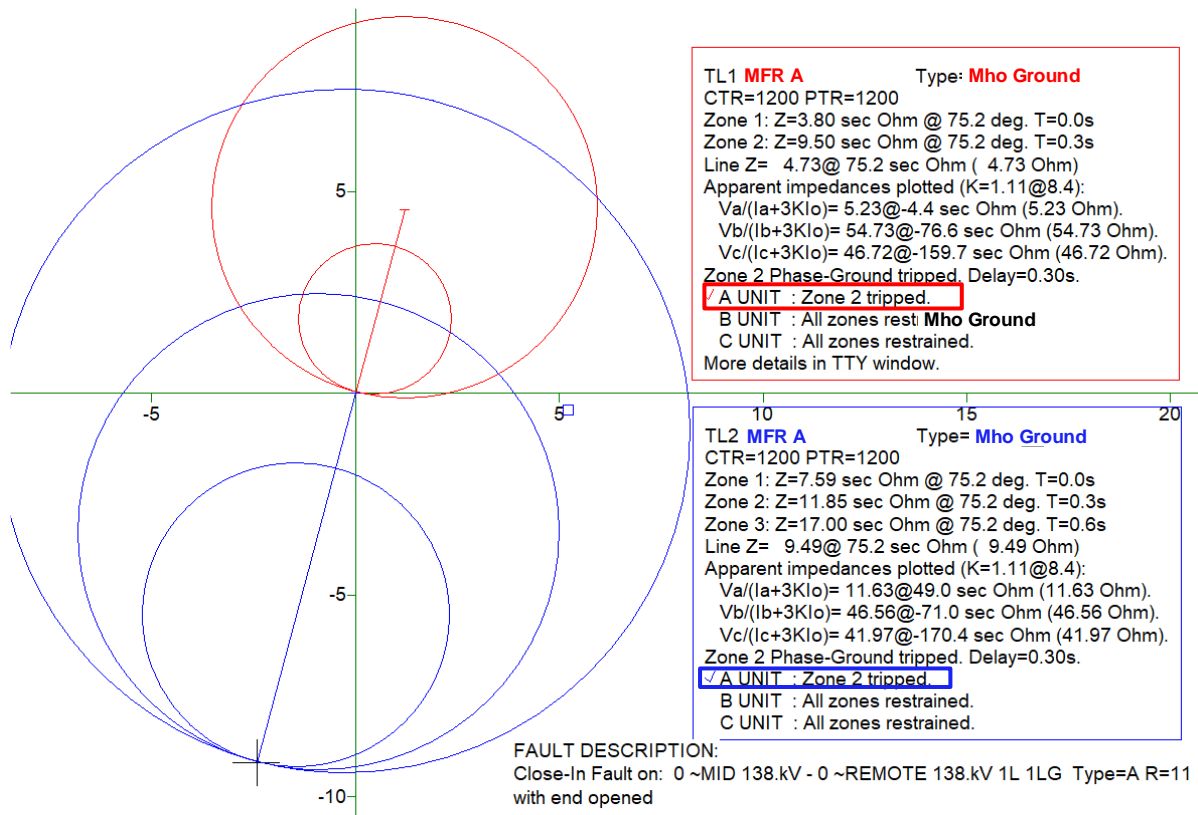

Figure 12 When primary relay reach is shortened, backup relay may operate simultaneously

Figure 10, Figure 11 and Figure 12 show the variability of coordination between primary and backup mho relays for resistive faults. Given that multiphase faults with significant resistance may occur occasionally (Section 3.1), and mho elements are applied more often as phase distance functions, it may be helpful to check limits of coordination for multiphase faults as well as for 1LG faults. Lack of complete coordination of mho elements for resistive faults are more likely when a short line follows a long line. A similar issue arises with quadrilateral elements; however, they provide greater flexibility for adjustment of resistive reach.

6. Coordinating resistive reach considering infeed

6.1. Effect of infeed

In transmission networks, many substations are terminals for more than two transmission lines. Other sources as shown in Figure 1 will often provide infeed to a fault that the primary protection will see, but the backup protection will not. This infeed will cause the backup distance relays to reach relatively shorter along the faulted line compared to the primary distance relays. The substations also often have transformers that provide a path for zero-sequence currents during transmission line ground faults. These transformers will also allow infeed of zero-sequence current that may make primary ground protection reach considerably further than the backup protection. The multiple sources provide infeed that will de-sensitize a backup relay with respect to a primary relay.

6.2. Effect of different quadrilateral measuring principles

As noted in Section 4, there are different principles used by manufacturers to implement a quadrilateral element. This section shows the effect of infeed and related considerations when adjusting the resistive reach for the different principles. A 50 MVA transformer is added to serve the load at MID bus as shown in Figure 13.

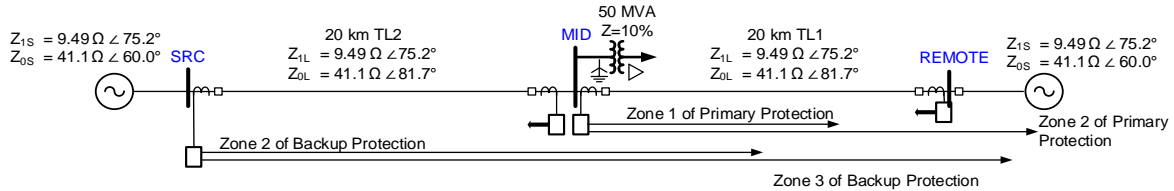

Figure 13 Example system with zero-sequence infeed at MID

Infeed from the transformer causes the apparent impedance calculated by the primary and backup relays to be different, as shown in Figure 14 using MFR B's zero-sequence polarized quadrilateral element.

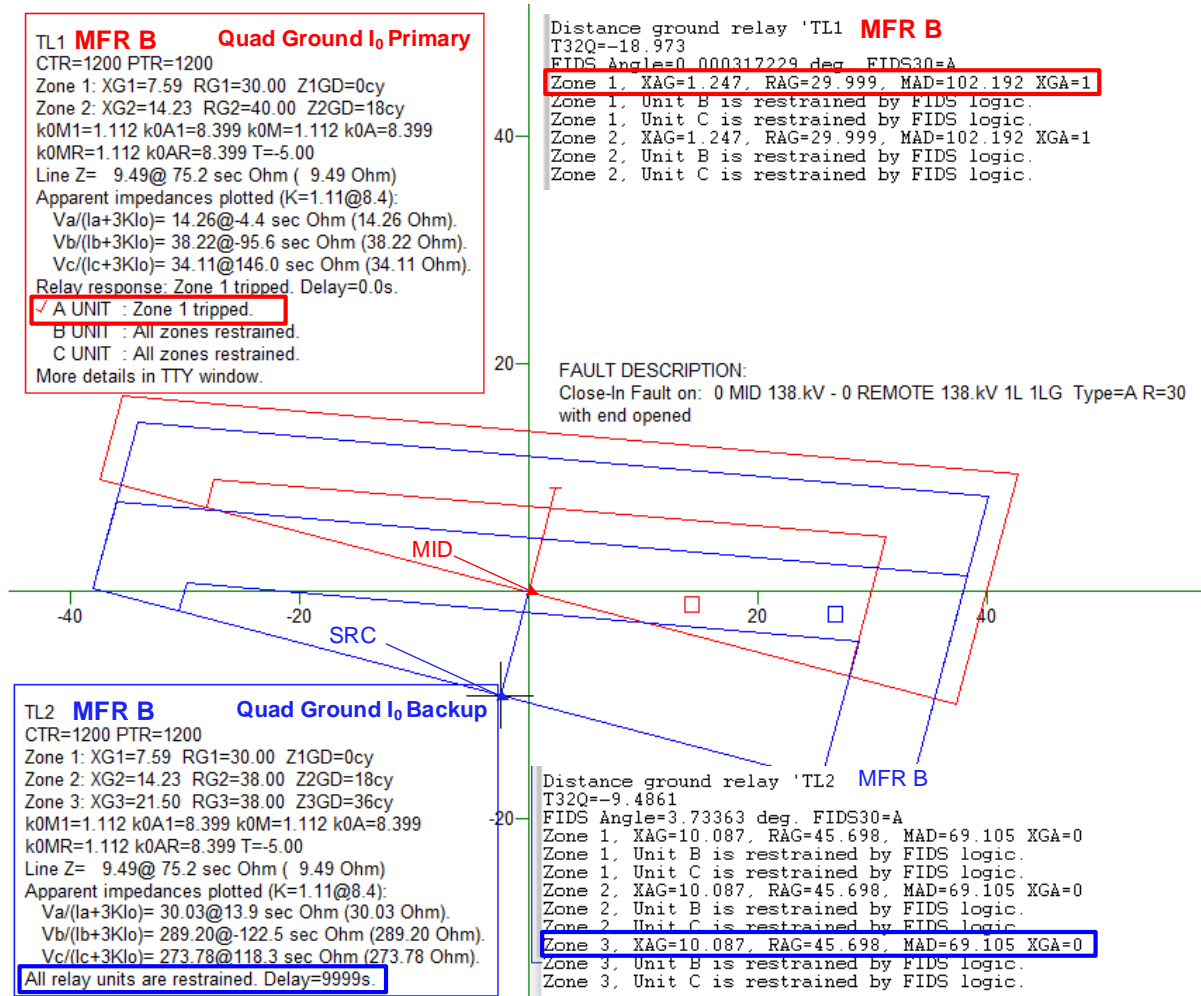

Figure 14 Coordination of ground quadrilateral element considering infeed

Figure 14 shows that for the 30Ω fault close in to MID on TL1, the primary relay calculates a 30Ω ground loop resistance. The backup relay, since it does not measure the zero-sequence infeed from the transformer at the MID bus, calculates a resistance of 45.7Ω. The Zone 2 resistance element reach is then set according to (4). Considering a security margin of 15% ($k = 0.85$) and a primary relay Zone 1 resistive reach of 30Ω, the resistive reach setting of the backup Zone 2 should be lower than 38.8Ω. Figure 14 shows that with a setting of 38Ω, neither the backup Zone 2 nor Zone 3 element operates.

$$R_{Set_Z2} \leq k \cdot \left(\frac{R_{Backup}}{R_{Primary}} \right) \cdot R_{Set_Z1} \quad (4)$$

Where:

R_{Set_Z1} is the Zone 1 resistance element reach of the primary relay

R_{Set_Z2} is the Zone 2 resistance element reach of the backup relay after considering infeed

k is a security margin

R_{Backup} is the resistance calculated by the backup relay for the fault

$R_{Primary}$ is the resistance calculated by the primary relay for the fault

The effect of infeed on the self-polarized quadrilateral element from MFR C is shown in Figure 15. Unlike the example of Figure 14, the resistance values are not reported but the distance zone detects the fault if the associated apparent impedance (as plotted) is inside its characteristic.

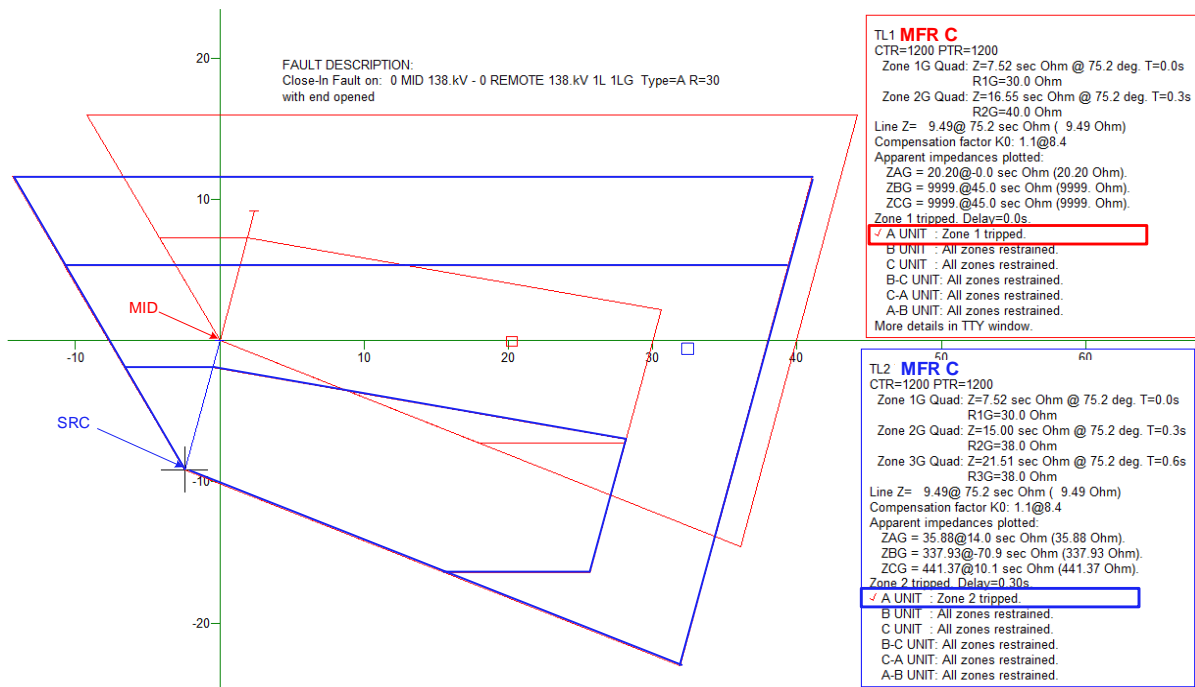

Figure 15 Coordination of self-polarized quadrilateral element considering infeed

Coordination can then be achieved by applying equation (5). Using the apparent impedances from Figure 15, a primary relay Zone 1 resistive reach of 30Ω and a margin of 15% ($k = 0.85$), the backup relay Zone 2 resistive reach should be lower than 40.8Ω . This value is larger than the resistive reach of the MFR B example shown in Figure 14 further demonstrating that the coordination should be checked for a particular manufacturer and operating principle.

$$R_{Set_Z2} \leq k \cdot \left| \frac{Z_{appBackup} - Z_{1L}}{Z_{appPrimary}} \right| \cdot R_{Set_Z1} \quad (5)$$

Where:

Z_{1L} is the positive-sequence impedance of the line associated with the backup relay

$Z_{appBackup}$ is the apparent impedance calculated by the backup relay for the fault

$Z_{appPrimary}$ is the apparent impedance calculated by the primary relay for the fault

7. Real Life Mis-coordination Example

A case is presented in this section, where the 230 kV supply to a substation was unnecessarily interrupted with significant consequences. The station was supplied by two 230 kV lines. There was a resistive fault on one line, and the backup protection on the second (healthy) line tripped at the same time as the primary protection on the faulted line. Note that in this case, the redundant, high-speed communications assisted protection on the faulted line did not operate due to the high resistance of the fault. The WEST terminal could not see the fault and weak-infeed echo feature at WEST was not enabled so the NORTH terminal did not trip with high-speed.

Figure 16 shows the reduced network diagram with the faulted 230 kV line (NORTH to WEST station) and the unfaulted 230 kV line (SOUTH to NORTH) that undesirably tripped simultaneously. The zero-sequence current ($3I_0$) magnitudes and angles to the fault in the faulted and the unfaulted lines are shown. Zero-sequence voltages (V_0 in pu) and angles at each of the stations are also shown. Network equivalent lines and generators are shown as black lines. A 1LG fault with a resistance of 65Ω was simulated at 4% of the distance from NORTH to WEST stations.

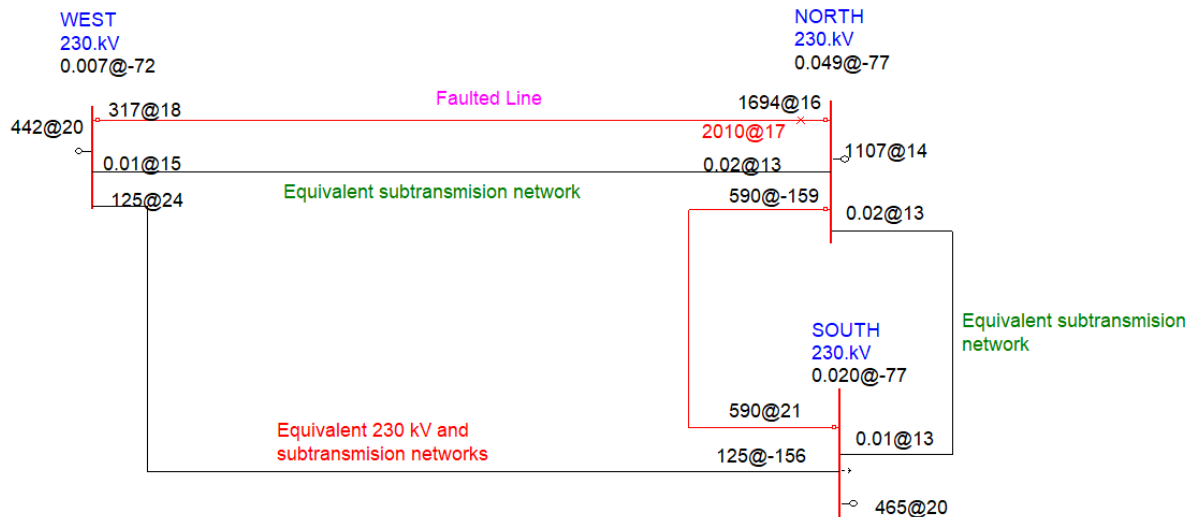

Figure 16 230 kV faulted network

The fault resistance was sufficiently high that the Zone 1 quadrilateral element at the NORTH terminal of the faulted line did not respond; so, it tripped after the Zone 2 time-delay. The Zone 2 element of the backup protection at the SOUTH terminal of the unfaulted line tripped simultaneously thus disconnecting 230 kV supply to the NORTH station.

Figure 17 shows the responses of the primary and backup relays to the simulated fault. It can be seen from the captions that the NORTH 21G Zone 2 function trips simultaneously with the SOUTH 21G Zone 2 function.

Note the small squares close to the x-axis on Figure 17, that show the apparent impedance presented to the NORTH 21G relay appears to be inside the Zone 1 characteristic of the NORTH 21G element. However, this is simply because the apparent impedance plotted on the diagram is the classical impedance (Z_{APP}) calculated according to Equation (1), while the relay algorithm uses a different measurement to determine the apparent resistance.

It can be seen from Figure 17 that the set resistive reach of the primary Zone 1 element is 5 Ω secondary, while the set resistive reach of the backup Zone 2 element is much larger at 26 Ω secondary. The larger resistance measured by the backup relay is due to infeed at North substation. The summary of relay quantities in Figure 17 shows that the resistance measured by the primary relay is 6.921 Ω , secondary which is outside the (5 Ω) reach of the primary Zone 1 element. The impedance measured by the backup relay is 18.463 Ω secondary, which is inside the (26 Ω) reach of the backup Zone 2 element. Therefore, the primary Zone 2 element operates at the same time as the backup Zone 2 element and the North Station loses its 230 kV supply.

To ensure coordination, the resistive reach of the backup Zone 2 element (R_{Set_Z2}) should be set using (4) with the values from Figure 17 shown in (6). For instance, if a 15% security margin ($k = 0.85$) is desired, we would set R_{Set_Z2} to a value less than 11.34 Ω secondary.

$$R_{Set_Z2} \leq 0.85 \cdot \left(\frac{18.463 \Omega}{6.921 \Omega} \right) \cdot 5 \Omega = 11.34 \Omega \quad (6)$$

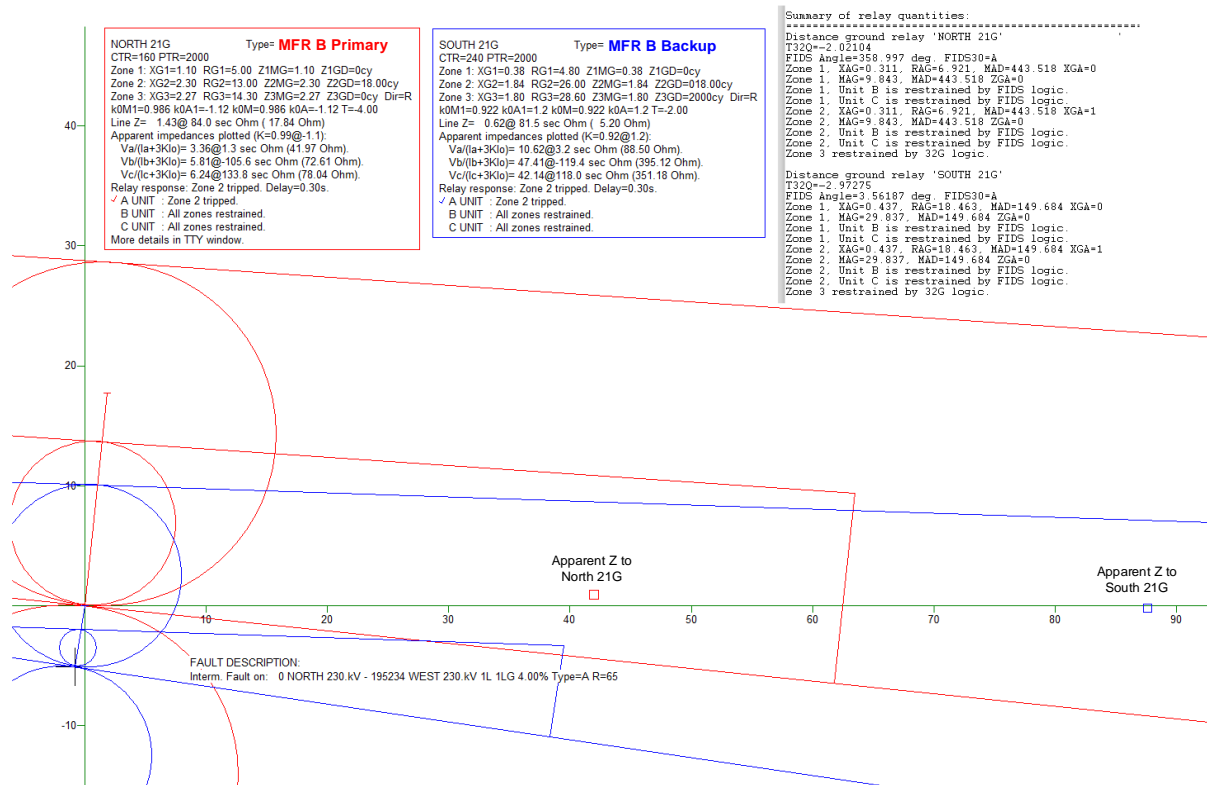

Figure 17 Reponses of primary and backup relays to the simulated fault

8. Checking resistive reaches using relay models in a computer program

The resistive coordination check can be performed after the distance relays are known to coordinate for bolted faults. In this section, we note practices that may result in mis-coordination and apply the principles discussed in the previous sections to provide an example of how coordination may be verified using a computer program. Different system operating conditions, including contingencies, should also be simulated but are not elaborated here.

8.1. Step distance Zone 2 coordination with respect to adjacent line Zone 1

Practices that may result in mis-coordination between step distance Zone 2 with respect to adjacent Zone 1 even when coordinating the same manufacturer's primary and backup relays include the following:

1. The ratio of resistive-to-reactance reach of Zone 2 may be set equal to that of Zone 1. Given that Zone 2 reactive reach includes another line, this may result in a greater resistive reach for the backup Zone 2. This can result in mis-coordination even when applying relays from the same manufacturer.
2. The reactance element tilt for the backup Zone 2 may be set greater (more positive) than the tilt of the Zone 1 it coordinates with. As evident from Section 4.3, this can result in a miscoordination.
3. Different polarizing options may be selected for the primary and backup relay pair, which can result in mis-coordination for resistive faults due to the effect of load, system non-homogeneity, or infeed.

Figure 18 shows an example of well-coordinated primary and backup distance zones for the system of Figure 13 with the transformer presenting infeed at the remote terminal in service. For a close-in fault with fault resistance of 15Ω , the primary relay Zone 1 operates whereas Zone 2 and Zone 3 of the backup relay do not. The relevant settings are described below:

- Zone 1 of Primary Protection:
 - Reactance element tilt = A tilt of -7 degrees depending on system non-homogeneity
 - Resistance element reach = $30\ \Omega$ with a tilt at the line angle
- Zone 2 of Backup Protection:
 - Reactance element tilt = The same tilt of -7 degrees as primary relay Zone 1
 - Resistance element reach = $38\ \Omega$ with settings calculated in Section 6.2 and coordination verified with infeed during various system contingencies

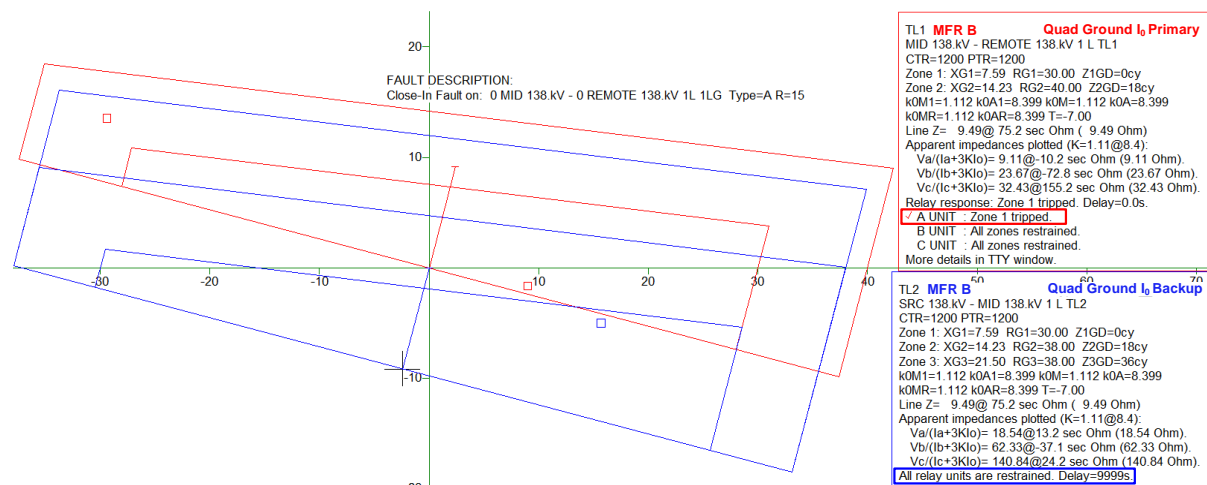

Figure 18 Zone 2 does not detect the fault and coordinates with Zone 1

8.2. Pilot reverse blocking zone coordination with pilot forward overreaching zone

For pilot protection, the reverse blocking zone of the protected line coordinates with the forward overreaching zone as shown for the TL2 relays in Figure 19. It is sometimes the case that the reverse zone is set by subtracting the line impedance, then applying a coordination margin. While this practice works well for bolted faults, it may not always work for resistive faults. It is of greater importance to verify coordination when applying dissimilar relays as part of the pilot scheme.

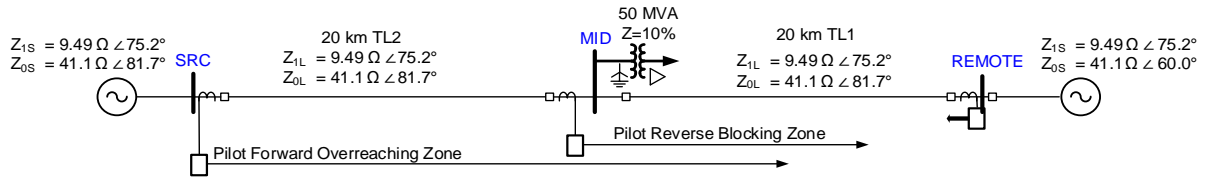

Figure 19 Example system showing relative reach of pilot reverse blocking zone with respect to pilot forward overreaching zone

Figure 20 shows an example of well-coordinated ground pilot mho zones with both the forward overreaching zone and the reverse blocking zone set with the same reach. Using the short-circuit program, we see that for a close-in reverse 10Ω fault, the blocking zone (Zone 5) picks up and coordinates with the overreaching zone (Zone 4) which does not pick up.

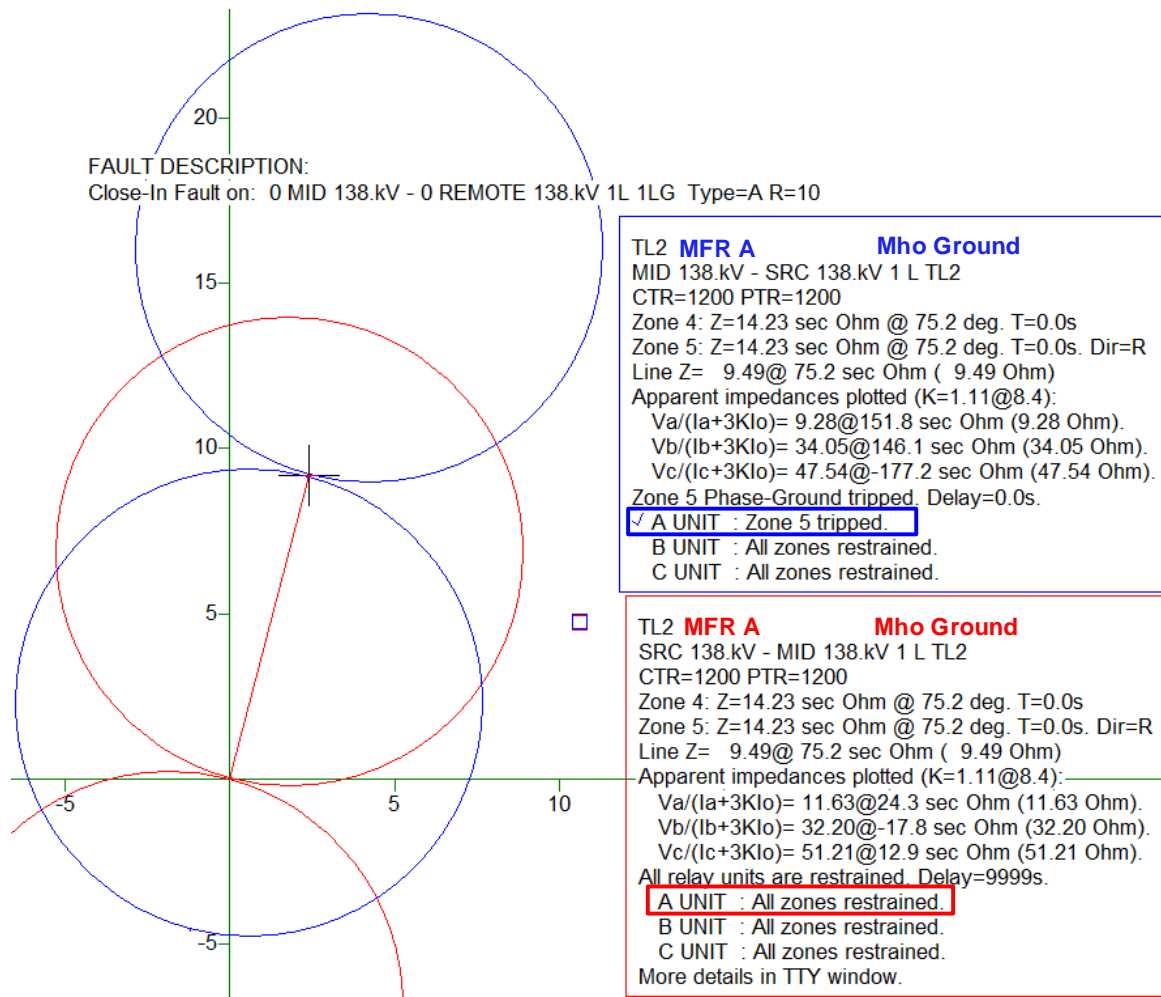

Figure 20 Pilot reverse blocking zone picks up and coordinates with forward overreaching zone

9. Conclusion

This paper has reviewed the possible need for coordination of resistive reaches of primary and backup distance relays. It is recognized that such coordination is not always achievable and is less important for phase distance relays than for ground distance relays. In rare cases, significant increase in arc resistance may be found in slowly cleared multiphase faults.

In the case of mho elements, reach in the resistive direction is not settable, and depends primarily on the type of polarization of the mho function. Different types of mho distance relays may exhibit different amounts of expansion of their characteristics in the resistive direction.

In the case of quadrilateral elements, different types of relays may have different algorithms to determine the resistive blinder reach. This may make the coordination of resistive reaches difficult to ascertain from mere observation of the characteristics on an RX diagram. In fact that the primary relay sees that the backup relay does not see can also complicate verification of coordination. It may be necessary to use accurate models of the relays in a coordination verification program to determine resistive reach coordination.

Users may consider reviewing their quadrilateral ground distance relay setting criteria to consider coordination in the resistive direction. In cases where resistive reach coordination of ground distance elements cannot be achieved using company specific criteria, relay setting engineers may consider reducing the resistive reach of the backup relay and placing more dependence on ground time overcurrent protection for highly resistive faults within the resistive reach of the underreaching zone of the primary relay [9]. Such resistive faults may not need to be cleared with the same speed as lower resistance faults.

10. Acknowledgements

The authors gratefully acknowledge the careful reviews of this paper, and helpful comments of Fernando Calero, Ryan McDaniel, and Ralph Barone.

11. References

- [1] Ward, S., "Comparison of Quadrilateral and Mho Distance Characteristic," proceedings of the 26th Western Protective Relaying Conference, Spokane, WA, October 1999.
- [2] Calero, F., "Distance Elements: Linking Theory With Testing," proceedings of the 35th Western Protective Relaying Conference, Spokane, WA, October 2008.
- [3] Terzija, V. V., Koglin, H., J., "A new approach to arc resistance calculation," *Electrical Engineering*, vol. 83, pp. 187-192, February 2001.
- [4] Miller, D., "Three Phase Bus Fault with Fault Impedance," proceedings of the 42nd Western Protective Relaying Conference, Spokane, WA, October 2015.
- [5] IEEE Std C37.113-2015 "IEEE Guide for Protective Relay Applications to Transmission Lines" IEEE, New York, 2015.
- [6] Lefrancois, M. J., "Mica 500 kV Protection — A Segregated Phase Comparison System with Special Features for High Tower Footing Resistance," proceedings of the 5th Annual Western Protective Relay Conference, October 1978.
- [7] Calero, F., Guzman, A., and Benmouyal, G., "Adaptive Phase and Ground Quadrilateral Distance Elements," proceedings of the 36th Annual Western Protective Relay Conference, Spokane, WA, October 2009.

- [8] Schweitzer, E., and Roberts, J., “Distance Relay Element Design,” proceedings of the 19th Annual Western Protective Relay Conference, Spokane, WA, October 1992.
- [9] Mohajeri, A., Seyedi, H., and Sabahi, M., “Optimal setting of distance relays quadrilateral characteristic considering the uncertain effective parameters,” *International Journal of Electrical Power and Energy Systems*, July 2015.

12. Appendix A - A high resistance self-clearing multiphase fault

In the field event discussed here, delayed fault clearing following a three-phase 138 kV fault resulted in the arc extending sufficiently to self-clear after around 10.6 seconds. A three-phase fault occurred on a line in a 138 kV network supplied from a 3000 MW generating station (GEN) as shown in Figure 21. The fault was located on the Line L138 between station GEN and WEAK.

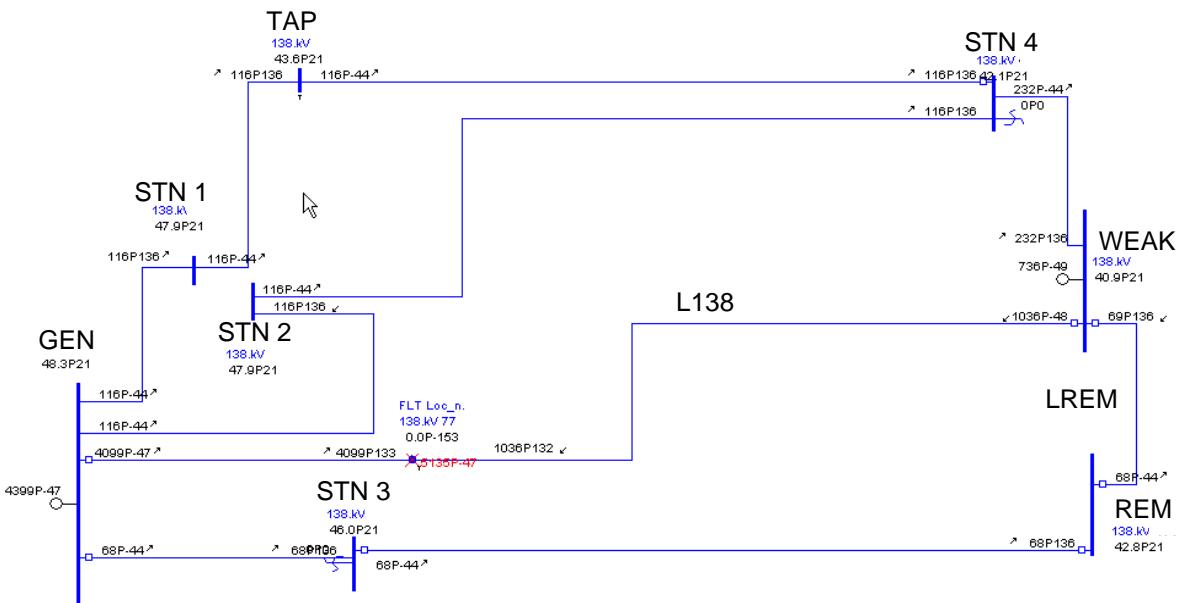

Figure 21 - Single line diagram of a faulted 138 kV line (L138) with simulation of the fault

Figure 21 does not show the detailed station arrangements. The 138 kV bus arrangement at the WEAK station is a ring bus, with two circuit breakers at the terminal. This fact is relevant because during the incident, one of the two breakers at WEAK failed to open, and the bus at WEAK became split.

A lightning initiated short circuit on Circuit L138 started as a three-phase fault and was promptly cleared by the GEN terminal. However, due to a breaker failure condition of one of the two breakers at WEAK terminal, the fault was not promptly cleared by that end. The fault was continued to be fed by the remote source of the adjacent circuit from REM to WEAK. None of the time-delayed overreaching zones (Zone 2 or Zone 3) at the REM terminal of the remote line operated. The GEN terminal was automatically reclosed 10 seconds later while the line was still energized from the WEAK terminal. By the time of reclosure of the GEN terminal, the fault, had reduced itself in severity from three-phase to a phase-to-phase (CA) fault. The GEN terminal was tripped promptly a second time while the fault continued to remain energized from the WEAK terminal. After some more time of unknown duration, the fault eventually cleared itself.

12.1.1. Sequence of Events

The relays initially reported a fault location of 22.98 km from the GEN relay, and 76.38 km from the WEAK relay. The observed currents and voltages at GEN and WEAK match well with fault study calculated currents and voltages (for a zero-ohm fault) at 23% of the line from GEN (see Figure 21). Therefore, it can be assumed that the fault started as a three-phase fault with negligible fault resistance. Figure 22 shows the responses of the relays at both terminals of the line to the initial fault. Some points to note about all the figures in this paper showing relay recordings.

- The analog plots are pseudo-oscillographic. They are plots of fundamental frequency components (phasor values) of currents and voltages after filtering to remove non-fundamental frequency component such as transient offset and harmonics. They are not plots of sampled values. This is the reason for apparent slow rise and fall of currents and voltages over approximately $1\frac{1}{4}$ cycles. The analog quantities are scaled in rms values. For instance, in the case of the GEN terminal recording, the magnitudes of the fundamental frequency components of the phase currents are approximately 4100 A rms.
- The vertical broken red line on the record shows the instant the recording function was triggered. There are always four cycles of pre trigger recording on each record.
- The captions of digital events have the following meanings:
 - ET is an external event trigger from a trip output from the second main protection. It allows comparison of trip times from the relay that recorded the event and the second redundant protection system.
 - 52A is a normally open auxiliary contact from both circuit breakers. It shows open when both circuit breakers are open.
 - OUTTP is a trip output from the relay that recorded the event
 - 21P is a phase-to-phase distance element. The distance relay principle is a compensator distance relay with a phase-to-phase element that operates only for two phase-to-phase faults. The number on the event plot shows which zone of the distance function has operated. In the case of the GEN terminal protection in Figure 22, the Zone 2 of the phase-to-phase element asserts transiently, then resets since the fault is a three-phase fault.
 - 213 is the three-phase distance element. It is the second part of the compensator distance protection function. It operates only for three-phase faults. The numbers on the event plot are similar to the phase-to-phase distance function event. In the case of the GEN terminal protection in Figure 22, the three-phase Zone 3 element picks up first and starts timing, but the Zone 1 element picks up only half a cycle later and the relay issues a trip command.

Figure 22 shows that the relay at GEN terminal issued a trip signal approximately 1 cycle after the fault started (when the currents can be seen to start to increase). The breakers at GEN cleared the fault from that terminal approximately 4 cycles after the trip command was issued (when the currents can be seen to start to decrease).

Note that plots of the fundamental frequency components include a filter delay that hinders precise timing of analog events. However, recordings of the filtered analog quantities facilitate comparison between real life quantities and fault study simulations which are only steady state fundamental frequency simulations.

Figure 22 shows that the protection at the WEAK terminal issued a trip command about $1\frac{1}{2}$ cycles after the fault started, but the fault did not clear. This is because one of the two breakers that needed to trip failed. The clearing of the fault from the GEN terminal can be seen in Figure 22 when the fault currents and voltages rise slightly as fault current contribution from the WEAK terminal increases. Post event testing of the breakers at WEAK terminal confirmed that there was a failure in the trip circuit in one of the two breakers.

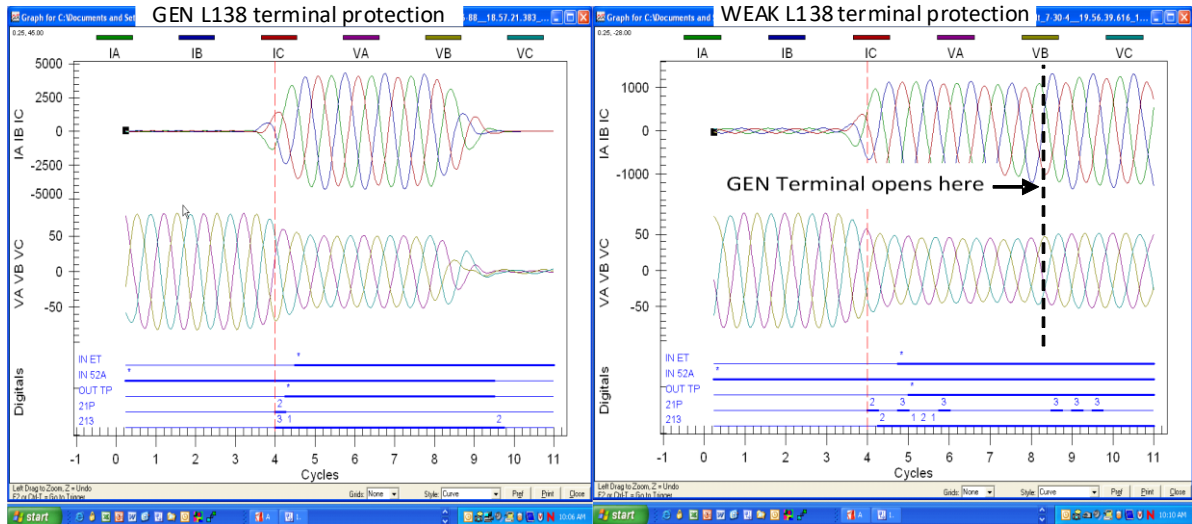

Figure 22 Recordings of initial three-phase fault from GEN (left) and WEAK (right) terminals

There was a small amount of negative-sequence current in the contribution from WEAK terminal that caused the phase-to-phase element to pick up intermittently during the fault, but the three-phase element (mostly Zone 1, with some instances of Zone 2) was picked up solidly the whole time.

The starting time of the initial fault will be set at $t = \text{time "T"}$ and the time of all subsequent events related to this time. At $T+0.17$ s, the breaker failure protection for the failed breaker at the WEAK terminal operated. Figure 23 shows part of the station arrangement at the WEAK terminal and which breaker opened and the failed breaker.

When the breaker failure protection operated, the bus at the WEAK substation was split, with faulted line L138 together with the line LREM becoming isolated from WEAK. At this time, a record was triggered on the protection at the adjacent WEAK terminal of line LREM. Figure 24 shows this record.

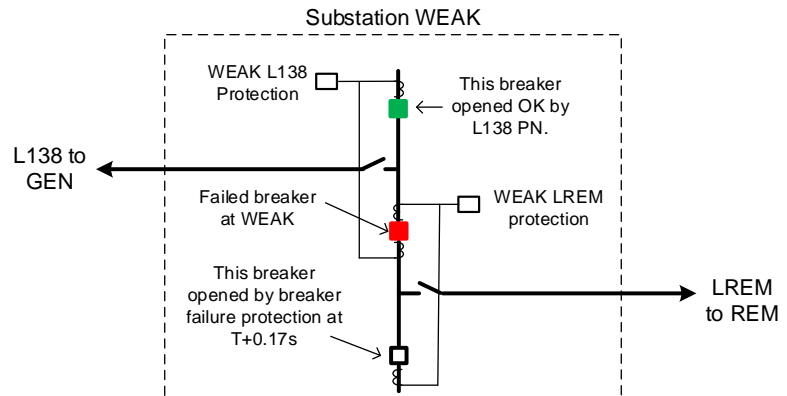

Figure 23 Single line diagram of part of Substation WEAK

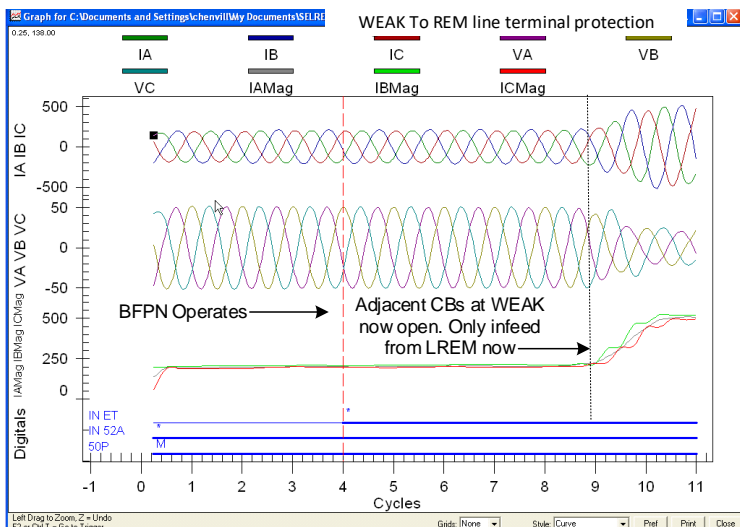

Figure 24 Infeed to WEAK Terminal from line LREM at $T+0.17$ s

Figure 24 shows that the current through LREM increases (and voltage decreases) at the moment all other infeed to WEAK is removed by the breaker failure protection. Now all the current to the fault is supplied through line LREM. There is no fault current supplied through STN 4 or from the local generator at WEAK.

Figure 25 shows the reconfigured system as simulated in post fault analysis. Note that the fault location was actually behind the WEAK terminal of line LREM, so even though an overcurrent function had started, no protection tripping elements at this terminal operated. Figure 25 shows that the magnitude of the positive-sequence fault current is significantly decreased from the initial total value of 5000 A to just over 500 A. The contribution from the WEAK terminal has decreased from just over 1000 A to just over 500 A.

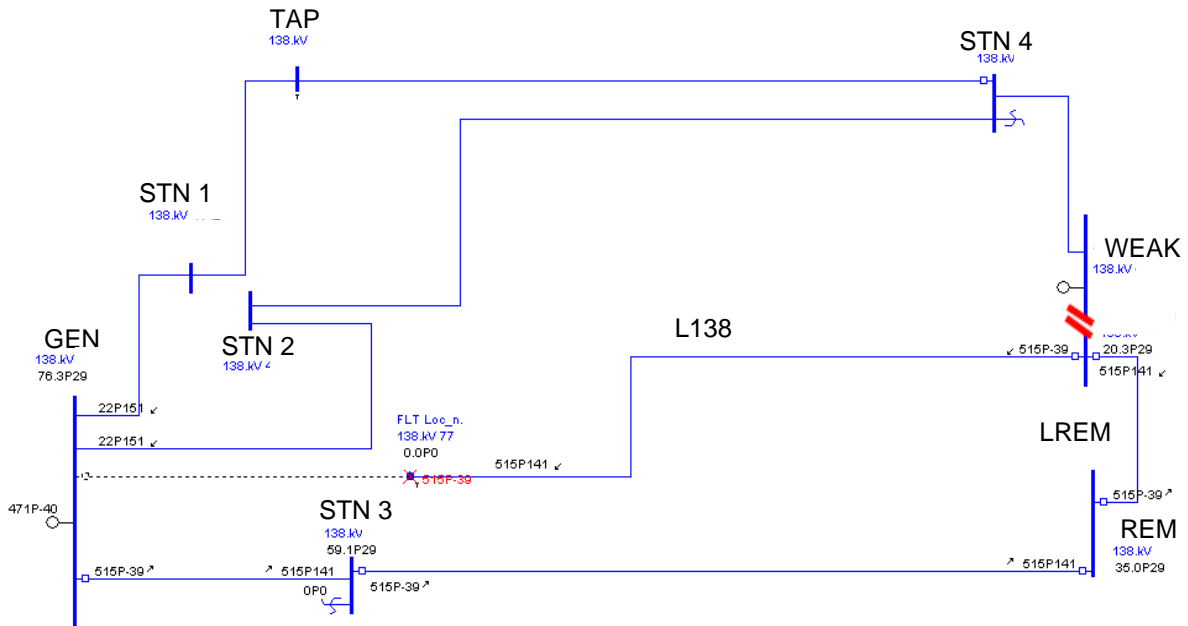

Figure 25 WEAK station reconfigured after breaker failure protection removes most infeed

At time approximately T+10 s, the GEN terminal of the line L138 was automatically reclosed. At the time of reclosure, the fault had degenerated into a phase A to phase C fault, and phase B was no longer faulted. GEN terminal tripped immediately, because the fault had never been completely cleared. A fault record, shown in Figure 26, was triggered at the WEAK terminal when the GEN terminal opened. This record was triggered by receipt of a direct transfer trip from the

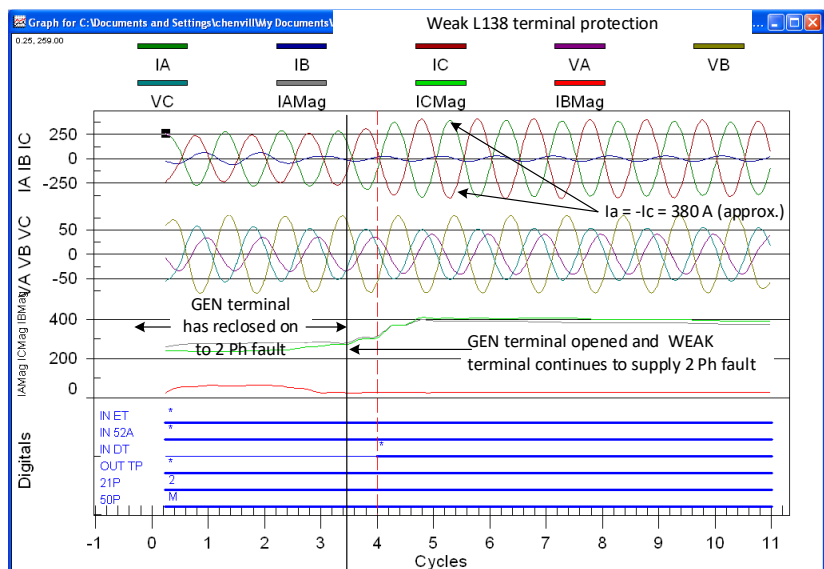

Figure 26 Record from WEAK Terminal after Automatic Reclose at GEN terminal of L138

GEN terminal. The fault remained energized from the WEAK terminal. Figure 26 shows that by the time of reclose, only a phase A to phase C fault existed. Note that although the WEAK terminal Zone 2 function is still asserted after 10 seconds, the breaker has failed to open.

The fault record shown in Figure 26 was simulated on a fault study and relay modeling computer program to try to replicate the currents, the voltages, and the apparent impedances presented to relays at WEAK and REM. The simulated result is shown in Figure 27. This figure shows the characteristics of two relays, one (colored blue) at the WEAK terminal of L138 and one (colored red) at the REM terminal of the line LREM.

The simulation showed that a phase A to phase C fault with a resistance of 80 ohms brings the phase A and C currents and voltages close to recorded values. The simulated impedances for a phase-to-phase fault with 80 ohms of resistance puts the apparent impedance outside the reach of the backup (at REM) distance function. It can be seen from Figure 27 that the high fault resistance prevents the backup Zone 3 function at REM station from tripping.

A later line patrol of L138 could not find any visible signs of damage at, or near the estimated fault location.

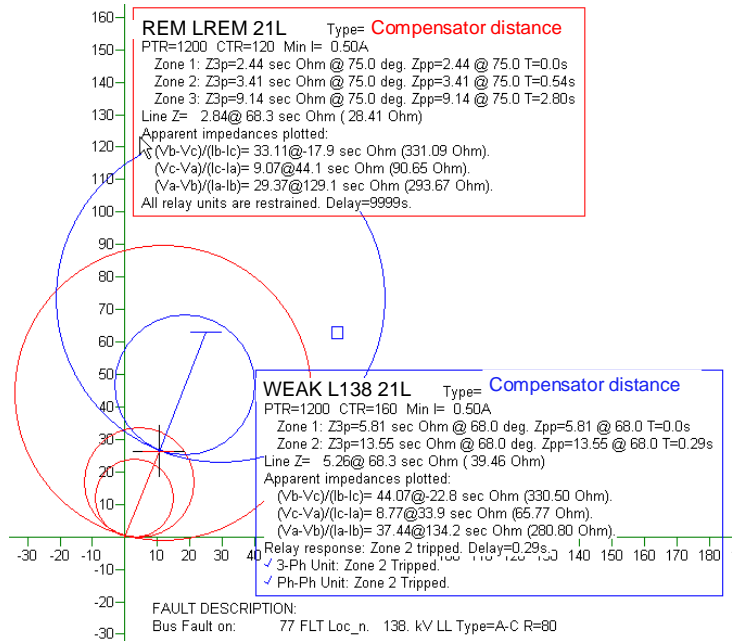

Figure 27 Responses of WEAK and BACKUP relays after GEN Terminal opens a second time