

Simplifying Protection System Design for Distribution Substations

Rich Hunt
GE Digital Energy
John Coursey, Stephen Hirsch
Orion New Zealand Limited

Presented at the Western Protective Relay Conference, Spokane, WA, October 16-18, 2012

Simplifying Protection System Design for Distribution Substations

Rich Hunt - GE Digital Energy John Coursey, Stephen Hirsch - Orion New Zealand Limited

1. Introduction

Orion New Zealand Limited (Orion) is a distribution utility that serves the city of Christchurch, the second largest city in New Zealand. Orion is adopting the technical capabilities found in the IEC 61850 standard and other technologies for a simple-to-implement, fit-for-purpose design for distribution protection. Orion is successfully using protective relays that provide multiple zones of protection in one device, and process bus communications, to simplify the design of their distribution protection. Careful system design allows the use of fewer protective devices, while maintaining the same level of protection system availability and reliability. Wiring and installation concerns are addressed by using process bus communications to provide remote I/O inputs for both analog measurements and digital control and status inputs, permitting the connection of only one cable to each relay. Benefits of this solution include a standard wiring design for all applications, fewer relay panels, faster installation, and simple expansion by simply connecting relays to process bus I/O units, while meeting performance requirements relating to device lifecycle, design and installation, safety, and commercial business requirements.

2. Rural Substation Protection and Control Upgrade

Orion had a project to upgrade the existing electro-mechanical protection at a number of relatively small rural substations. These rural substations are very simple in design, and use metal-clad or metal-enclosed switchgear installed in buildings as the heart of the substation. A typical substation has as a source a 66kV or 33kV sub-transmission line, and uses 11kV as a distribution voltage. The goal was to replace the electro-mechanical protection (as in Figure 1) with microprocessor relays to gain the advantages of convergence of technology, such as included metering, SCADA communications, and recording, while simplifying the wiring design and installation. Such a project has several performance requirements beyond the standard requirements of protection and control system reliability and budget limits that any possible solution must meet, including:

A focus on protection system lifecycle. Microprocessor relays have a much shorter lifespan relative to the actual switchgear. Relays are expected to last around 20 years, while switchgear can be reasonably expected to last 40 years or more with proper maintenance. This lifespan introduces a concern about future upgrades and replacement, as the rapid pace of change in microprocessor technology means the relays installed today are unlikely to be available two decades in the future. Therefore, any solution should design from the start a method to support simple replacement of relays in the future.

Design and installation. The typical retrofit project is a *custom* project, in that all parts of the protection and control system, and the refurbishment / upgrade, is designed for the specific project at the specific substation. Even with the use of standard designs, this potentially leads to a significant design effort for every project. Relay panels or switchgear doors must be designed for every project, and much of the wiring installation must be done on-site. This also means that a focus on protection system lifecycle is more difficult, as a significant project will be required in the future to upgrade or replace protective relays. Therefore, the goal is to standardize the design as much as possible, and to separate protective relays away from the primary equipment.

Safety. Protective relays mounted directly in the switchgear cabinets introduce safety concerns for operating personnel, such as arc-flash hazards and risks during circuit breaker operations and breaker failure events. The strong desire is to place the relays in a separate room from the switchgear, depending on the space available in the substation building. This ideally separates operating personnel from high energy signals as much as practical.

Business pressures. The obvious business pressures are to keep the cost of any project to a minimum, and to keep project costs as predictable as possible for budget planning. Also, there is a strong pressure to maximize the utilization of technical resources, meaning, in short, to require the least effort and least skills possible to perform the project. A good design for this refurbishment process should also minimize the time and resources needed for future refurbishment, expansion, and upgrade projects. This requires that any new system design and technologies adopted minimize training, learning, and the acquisition of new skills.

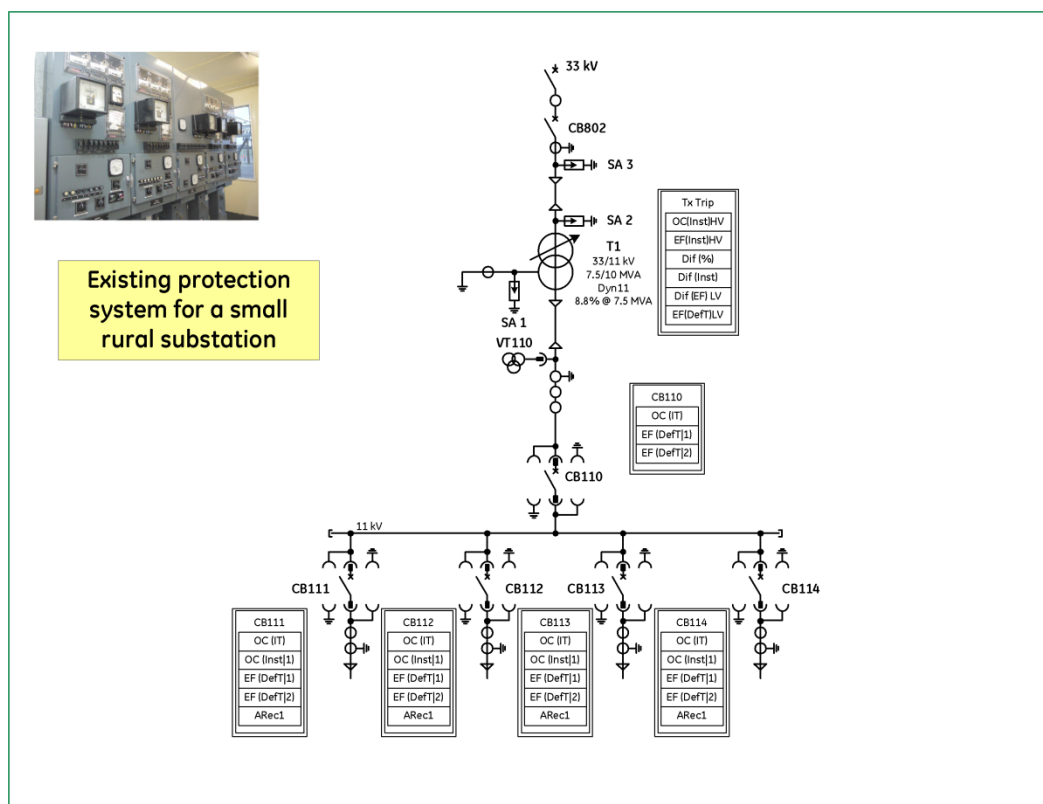

Figure 1: Existing protection system

1.1. Initial protection system design

A protection system design for the small rural substation based on the standard technology in use today will use one protective relay for each zone of protection. To meet the project requirements for lifecycle, safety, design, and cost, the normal path would be to install new microprocessor relays in separate protection panels, and mount the protection panels in a separate room from the switchgear. Figure 2 illustrates this typical initial design. The project then becomes designing new protection panels, designing the wiring from the switchgear to the protection panels, cutting out the old wiring, installing the new panels, installing the field wiring between the switchgear and the relay panels, and installing new doors for the switchgear. Based on the typical microprocessor relay, this

does the best job of meeting the project requirements. However, the design still has some limitations versus the project performance requirements:

Protection system lifecycle. Placing the relays in panels separate from the switchgear addresses the protection system lifecycle. Future upgrades and replacements are a matter of replacing the relay panels. However, this is not a completely optimal solution. New relay panels will still need to be custom designed to interface with the copper field wiring at a specific substation. This also requires future replacement projects to completely cut out the relay panels and install new relay panels.

Design and installation. The rural substations will use a standard protection system design, and the relay panels will use a standard design. However, modifications to the design will be required for every substation. Every signal point will have to be wired between the switchgear and the relay panels in the field.

Safety. Mounting the protective relays in separate panels means operating personnel do not have to be in the switchgear room during normal procedures. However, high energy signals from CTs and VTs are still present in the relay panels.

Business pressures. Using a standard design, and building the relay panels offsite, significantly reduces the cost, time, and resources required for the project. There are no new concepts, tools, or skills required, so the only training is on the new design. There is also no reduction in skills and training required. However, every project is still a custom designed and custom installed project. Furthermore, future projects to address protective relay lifecycle remain a custom engineered project.

The obvious conclusion is that the copper field wiring is the major limiting factor in meeting the project requirements to upgrade the protection system at these small rural substations. Each piece of data used by the protective relays requires a pair of copper wires, which must be designed and installed. As the actual wiring locations and data available are different for each project, each project requires significant engineering effort. An optimal design to meet the project requirements will reduce the impact of field wiring as much as possible.

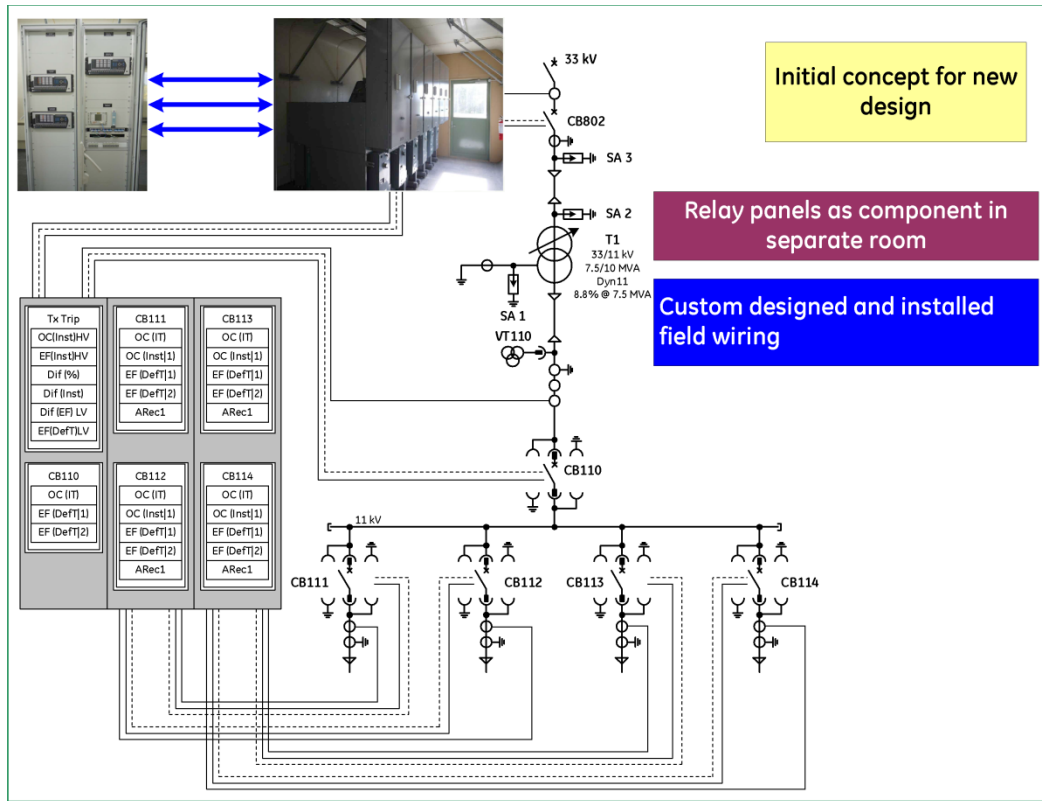

Figure 2: Initial protection system design

Beyond that of field wiring, another limiting factor is that the traditional design uses one relay for each zone of protection. Each relay requires significant field wiring to acquire current measurements, voltage measurements, circuit breaker status information, and circuit breaker control points. The amount of field wiring involved is both time consuming, costly to design, and install and also requires a significant amount of panel space to accommodate all the wiring. As a result, a reasonable expectation is that only 2 feeder relays will be mounted in one control panel. Therefore, the limitation of the technology, the microprocessor relay, limits the methods to improve or simplify the protection and control system design.

1.2. Technology to improve the design

There is existing technology that addresses the issues of designing and installing field wiring, and the number of protective relays required for protection. The constraint on using technology is more the perception of the functionality or practicality.

Field wiring, and field wiring design and installation, is directly addressed by the IEC 61850 standard for digital communications in a substation. However, the perception of what the standard is, or should be, limits the practical applications and design choices. The term "IEC 61850" is associated with many concepts, and has negative connotations that include "complicated", "complete change in design philosophy", and "communications network based". This results in the perception that IEC 61850 technology is not ready for widespread adoption, or is too complex to be of value for simple projects such as a protection for a small rural substation. A particular perception is that IEC 61850 requires a significant learning curve in software and communications skills to deliver protection and control solutions.

Multiple zone protective relays that provide up to 6 zones of independent protection exist today, and are commercially available. However, their use is limited, as the perception is that field wiring is a significant issue. Assuming each feeder requires 4 currents, 3 status points, and 2 control points results in each feeder requiring 9 pairs of copper wires. This requires 54 pairs of copper wires for such a relay, a difficult and impractical design. Other perceptions include that operating and maintaining such a relay is more complex procedurally, as isolation for test is more difficult.

1.3. IEC 61850 technical concepts

To address this negative perception of IEC 61850, and multi-zone protective relays, it is useful to look at the three powerful technical concepts contained within the IEC 61850 standard. These concepts are self-description of data, peer-to-peer communications of data, and the publishing of sampled value data. In IEC 61850, self-description of data is accomplished through the object-oriented modeling of logical nodes. Peer-to-peer communications include GOOSE messaging to replace field wiring between devices, and client-server communications through the MMS protocol. Sampled value data is the use of “merging units” to sample currents and voltages, and to publish these samples in a digital format so that microprocessor devices can use these samples for magnitude and angle measurement for protection and metering purposes.

The major limiting factor facing Orion in terms of the project performance requirements is that of field wiring. The present method is to bring all analog signals to the relay using copper wiring. Each piece of information requires 2 wires. Every one of these wires, and their associated terminations, must be designed, installed, and commissioned. Looking at the technical concepts within IEC 61850, both GOOSE messaging and sampled value data have the capability to replace field wiring with digital communications over fiber optic cable. When interfacing between primary equipment in the substation, such as switchgear, and relays, this is commonly known as “process bus”. Essentially then, the result can be separating physical I/O from the protective relay. Once I/O is removed the relay, repeatability of design, the lifecycle of protective relays, safety, and project costs, both now, and in the future, are significantly improved. Also, it may be possible to use protective relays that provide multiple zones of protection in one device to further simplify the protection and control scheme, as copper field wiring between the switchgear and the relays is eliminated. So the concepts contained in IEC 61850 provide the capability to deliver a solution for Orion.

So a more optimal solution is provided through the technical capabilities contained in the IEC 61850 standard. However, there is still the issue of the perception of difficulty to apply IEC 61850 based systems. However, IEC 61850 doesn't have to be complex, or more complicated than present day solutions, or require a complete change in design philosophy, or require a significant learning curve. Any use of the concepts contained in IEC 61850 should be a “fit for purpose” use, designed for the specific application and project, and for the requirements of Orion specifically. The project then becomes to design a solution, using the concepts and methods of IEC 61850, that is the best solution for Orion's business needs and performance requirements. The key is to have a fit for purpose solution that is driven by the needs of Orion, and not by the industry perception of what the IEC 61850 standard should be. It is important to remember that the IEC 61850 standard itself does not define applications or designs, but simply describes the formats, building blocks, and methods for possible solutions.

2. New Tools to Use

To really deliver the performance requirements, an intelligent solution designed around the concept of process bus, using the concepts of IEC 61850, seems to be the best solution. The solution Orion designed is built around 2 relatively new tools: the process interface unit, and the multiple zone protective relay.

2.1. Process interface unit

The process interface unit (PIU) is an electronic device intended to be the complete I/O interface of primary equipment for the protection and control system. Essentially, the PIU is a merging unit (that publishes sampled value data) combined with contact I/O for device status and control points. The PIU is designed to become part of primary system equipment, directly connected to current transformers, voltage transformers, and switchgear status and control circuits. PIUs therefore convert analog signals to digital signals, and publish all data using IEC 61850 message formats over fiber optic cable.

A PIU may be as simple or as complicated as required to meet specific application requirements. The PIU Orion selected for use in rural substations is a simple design, packaged in an environmentally rugged case suitable for outdoor mounting, as in Figure 3. All cable connections to the PIU use industry standard aviation style screw-on connectors, to provide simple tools-free installation and removal. This PIU also uses a simple, fit-for-purpose, point-to-point communications architecture that doesn't require network equipment or even an understanding of communications technology. Learning to use this PIU is a simple understanding of capabilities, with no special tools, skills, or background knowledge required. Each PIU has sufficient I/O (either 8 currents, or 4 currents and 4 voltages, and contact I/O) to be the I/O interface to 2 feeders simultaneously, and can establish a point-to-point connection to 4 different devices independently. The communications uses a specific profile for sampled value data and GOOSE messages compliant with the IEC 61850 standard.



Figure 3: PIU

2.2. Multiple zone protective relay

There are a variety of multiple zone protective relays commercially available. The relays that Orion selected for this project include the required IEC 61850 profile to communicate with the selected PIU. There are 3 models of this multiple zone relay available: a feeder relay that protects up to 6 feeders (including reclosing) independently, a bus differential relay that protects 6 sources and 6 feeders, and transformer protection that protects up to 6 windings and 6 feeders. Each one of these relays can connect to up to 8 different PIUs for measurements, status, and control.

3. Installation in a Small Rural Substation

For this project of upgrading the old existing electromechanical protection at a number of relatively small rural substations, Orion designed the protection and control system using PIUs and multiple zone protective relays. Orion had previously installed and proven the concept of PIUs in 66 kV outdoor substations where the benefits of the system are more obvious because of the long secondary cable runs required. Figure 4 shows the single line diagram of an Orion 7.5 MVA 33/11 kV substation with 33 kV line breaker, 11 kV incomer and 4 feeders with the location of the PIUs and the protection functions. The PIUs (which are IP66, NEMA 4X (dust-tight, protected against powerful water jets) and so can be mounted outside) are available in two versions: 2 sets of three-phase currents or 1 set of three-phase currents and 1 set of three-phase voltages. Orion has chosen to use one PIU with 2 sets of current inputs per pair of feeders, one PIU with the current and voltage inputs on the incomer and one PIU with current and voltage units on the 33 kV breaker.

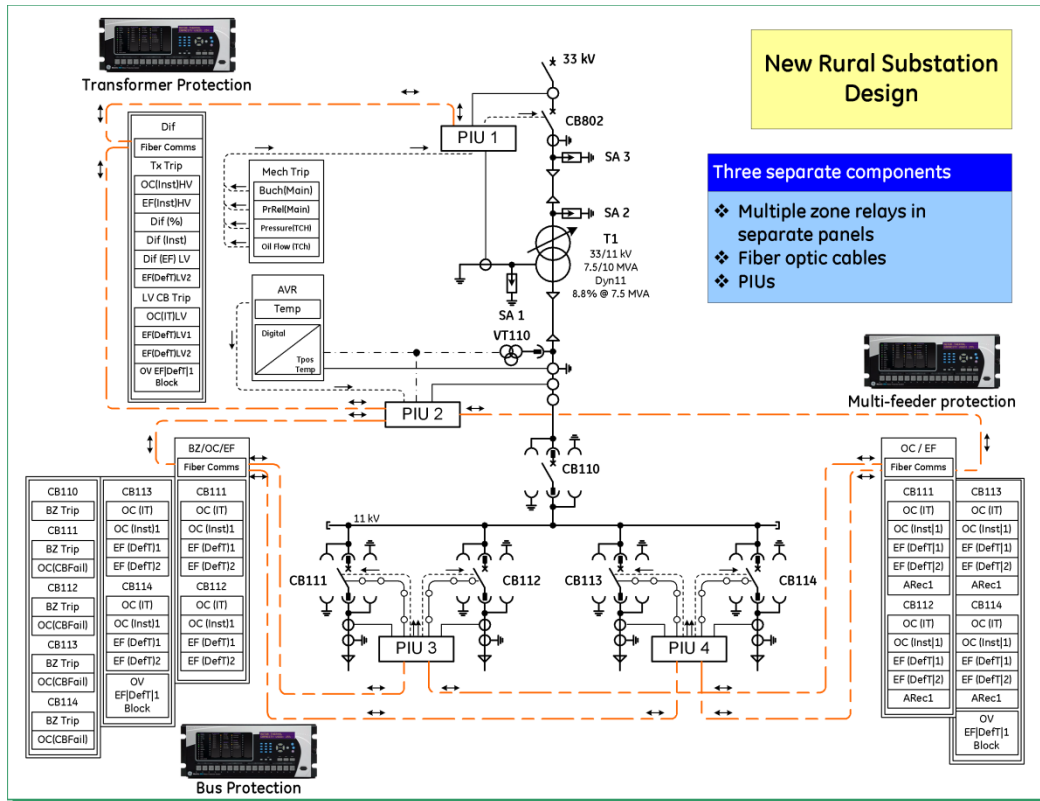

Figure 4: New small rural substation design

For economic reasons, Orion chose to accept a common mode of failure by sharing 1 PIU between 2 feeders. If this is not acceptable, the selected relays allow you to duplicate the PIUs to operate in a redundancy/hot standby mode. The settings allow the redundancy/hot standby operate in Security mode (if the 2 PIUs report discrepancies – block the protection) or Dependability mode (if a PIU reports trouble continue using data from the other PIU), or to simply use a single PIU per feeder.

For this design, Orion chose a multiple feeder relay for the feeder protection to protect all 4 feeders (including reclosing), a multiple zone bus differential relay for the bus zone protection which also provides full duplicate feeder backup protection and circuit breaker fail (CBF), and a transformer differential protection relay. This design means that only three IED's/protection relays (apart from transformer temperature monitoring and voltage control) are needed for the whole substation.

Figure 5 through Figure 9 show the resulting relay and circuit breaker panels. Note the almost complete lack of wiring in the rear of the relay panels. The only connections to the relays are their power supply, the fiber jumpers to the PIUs and a communication link for SCADA and engineering access. The PIUs are mounted in the front panels of the 11 kV switchgear and connect directly to the current transformer, voltage transformer, and control terminal blocks in the switchgear. A single PIU is mounted outdoors on the 33 kV breaker. Figure 10 shows a traditionally wired relay panel with two similar relays for comparison. Local controls use the push buttons on the front of the protection relays and GOOSE messaging is used to transfer CBF initiate and bus zone undervoltage supervision between relays over the process bus optical fibers.



Figure 5: 11 kV Switchgear



Figure 6: PIU mounted in 11 kV switchgear

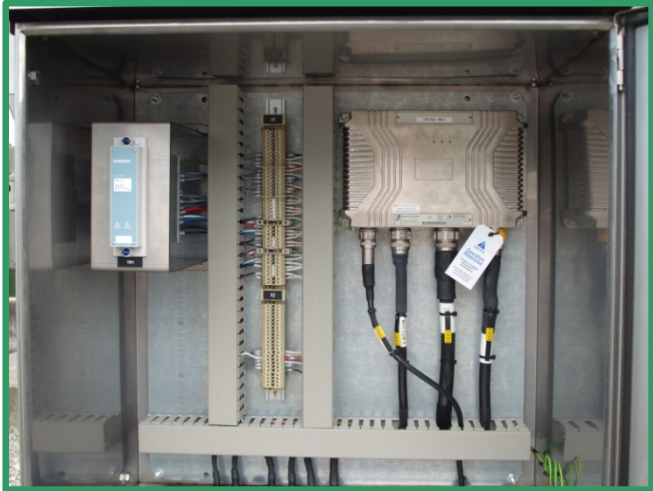

Figure 7: PIU mounted in 33 kV breaker



Figure 8: Front view of relay panels



Figure 9: Rear view of relay panel



Figure 10: Rear view of traditionally wired panel

3.1. Fiber cabling distribution

The connectorized cables for connecting to the PIU, and to the relays, can be supplied by the manufacturer of the PIU and relays, or can be sourced from any cable manufacturer. The fiber optic cable that connects to the PIU also contains a pair of copper wires to provide DC power for the PIU. Orion has taken this concept of the combination fiber optic / copper cable to simplify panel wiring design even further. One of the relay panels has both a fiber optic patch panel to connect relays to PIUs, and DC distribution bus to power relays and PIUs. The same combination cable is used between this panel, the relays, and the PIUs. At one end, the copper wires in this cable are connected to a mini circuit breaker on the DC distribution bus, and the fiber cables are connected to the patch panel. At the other end, the copper wires are connected to the relay DC power inputs, and the fiber cables are plugged into the relay fiber optic ports. Or, at the other end, the copper wires and fiber cables are connected to the aviation-style connector, and attached to the PIU. The difference between the two ends then simply is a matter of the type of termination. This simplifies the design of the panels and wiring, and reduces the number of components required.

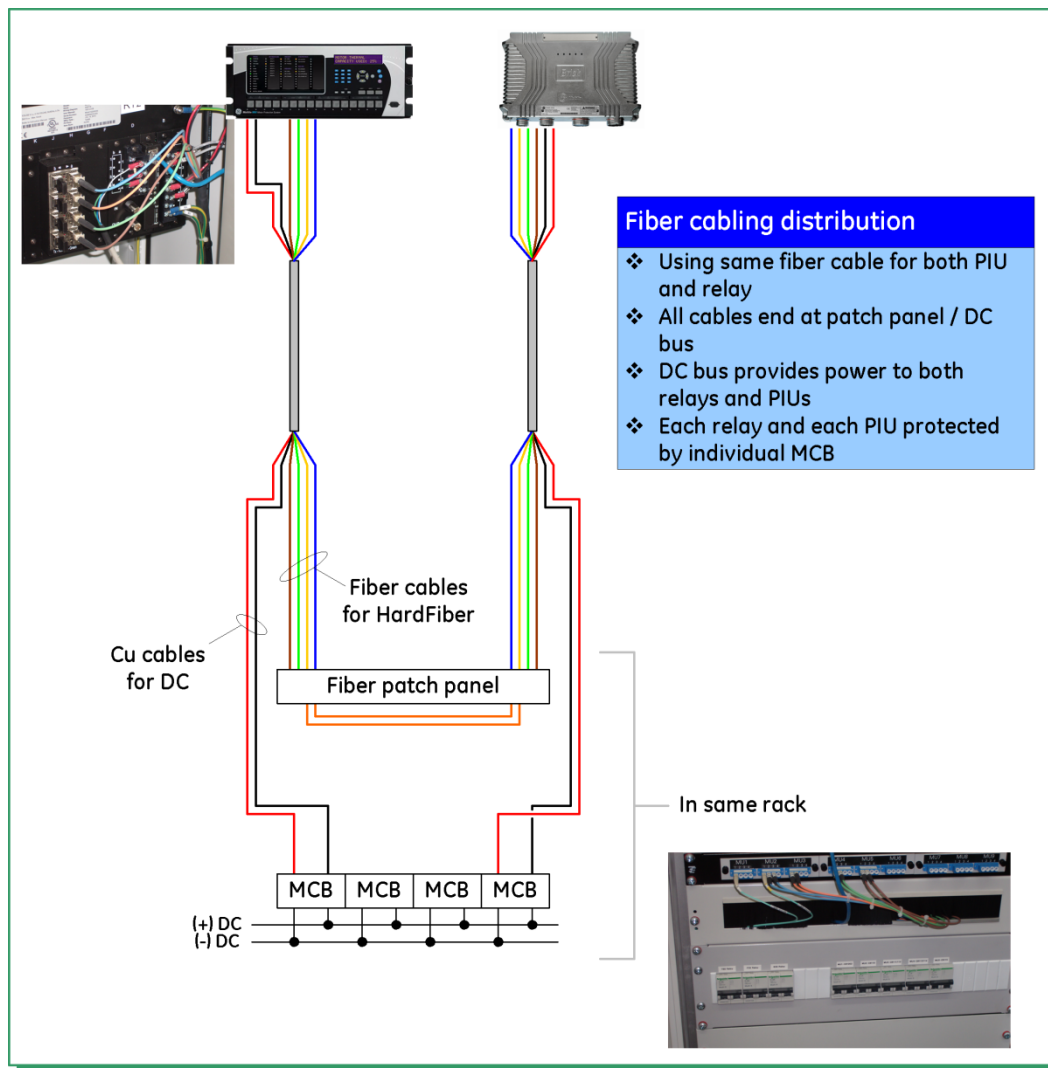

Figure 11: Fiber cable distribution

3.2. New design and performance requirements

This new design better meets the performance requirements for the protection and control system design for the small rural substations. Separating the field wiring and I/O from the protective relays makes the system design a component-based design that simply connects together. Each component is an independent piece that can quickly and easily be replaced or upgraded. Specifically:

Protection system lifecycle. Relays are placed in panels separate from the switchgear. These panels contain almost no copper wiring, and the same panel design can be used for every substation. Future upgrades require simply swapping the fiber jumpers from one relay to a different relay without replacing or modifying the panel. The model, type, and function of relay is unimportant: the relays interface to all available signals by connecting to the fibers from PIUs. Future replacement of PIUs is also the simple matter of swapping cables from the old PIU to the new PIU through the aviation-style connectors.

Design and installation. The relay panels use a standard design for all applications, as copper wiring is limited to DC power and grounding. All other connections in the panels are via fiber optic cable. The PIUs are mounted and wired into the switchgear, with a standard design for every

model of switchgear breaker. This design is extremely repeatable. Field wiring is limited to installing the PIUs in the initial project.

Safety. Relays are mounted in panels in a separate room from the switchgear. There are no high energy signals in the panels, as the only connection to the switchgear is a fiber optic cable.

Business pressures. Relay panels use a standard design, and may be built offsite. Relays can be commissioned while the panel is being built, by testing through loose PIUs as part of a factory acceptance test. Multiple relays may be mounted in one relay panel, as there are no concerns about space for wiring. (Orion has mounted 6 relays in one panel using this method. The time and effort needed for an upgrade project is significantly reduced. Future upgrades will simply involve quick swap outs, and patching and unpatching between fiber optic cables. Custom design is therefore reduced. Using multiple zone protective relays reduces the number of devices required, reducing project cost. There is no special training, learning, or background skills required beyond that of traditional protection and control skills.

3.3. Larger substations

Orion also uses the same general design developed for small rural substations in larger distribution substations as well. For these larger substations, the design is simply expanded. One PIU is shared between every 2 distribution feeders. One multiple zone feeder protection relay connects to 2 PIUs and protects 4 feeders. The only difference is in the selection of the specific model of bus protection relay. The bus protection relay provides the same functionality as in the small rural substation design, but this model has the capability to connect to 16 PIUs and provide protection for 24 bus sources and distribution feeders.

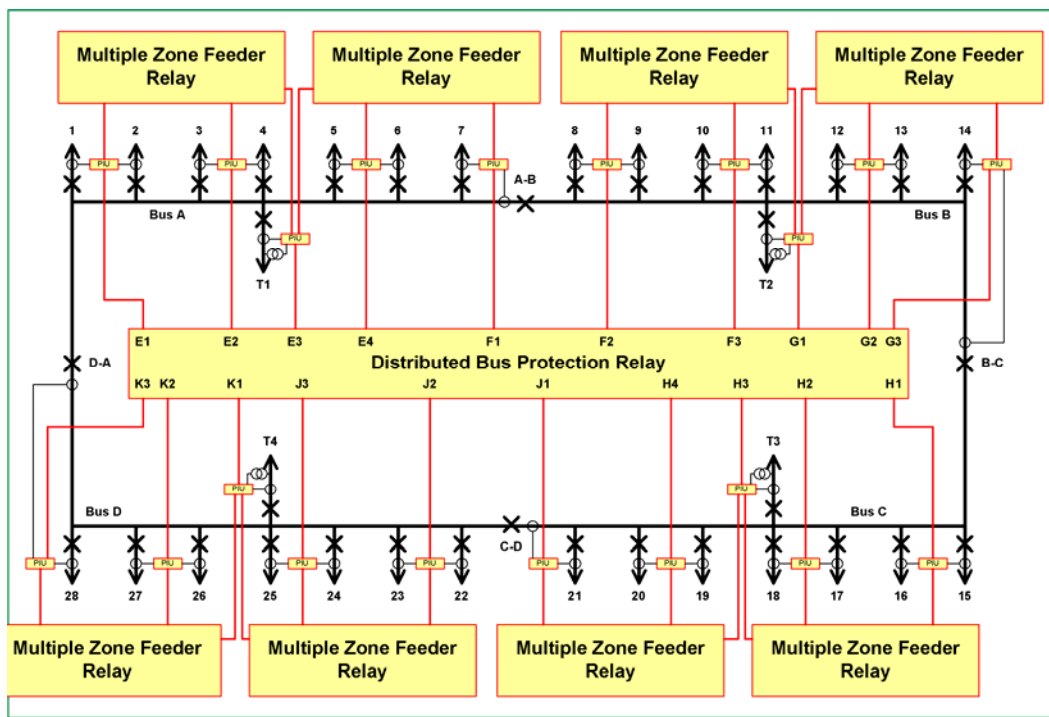

Figure 12: Large distribution substation

4. Economics

The “business pressures” of the rural distribution upgrade projects is most directly about economics. It is difficult to generalize about costs, however the panel build costs for Orion have escalated recently and it is not uncommon for a relay panel with reasonably extensive internal wiring to now cost upwards of \$10,000. As an example of costs, each connector block now costs approximately \$10 and multi-core secondary cable costs can be over \$20 per meter. The use of PIUs and fiber dramatically reduces the amount of both components required along with a significant amount of wiring. Orion estimates of the cost comparison with a traditional installation in a small substation such as this (one relay per feeder, hard wired) are that the costs are very similar. The IEC 61850 Process Interface Units installation may be slightly more expensive; however the added benefits in flexibility may frequently outweigh the initial slightly higher costs. For the illustrated substation, after the design was finalized and under construction, a large dairy factory was built in the area, requiring extensive upgrading of the sub-transmission network to meet reliability and quality of supply requirements. Orion needed to retrofit three ended line differential protection to the incoming 33 kV line and later upgrade the line to 66 kV. All that was required in terms of installation was to mount a relay in one of the existing panels, connect power and plug in a couple of optical fiber jumpers and it will be operational - a couple of hours installation work followed by commissioning tests. (You do of course have to also configure the IED/relay).

5. Other Design Factors

The system as designed meets the project performance requirements of Orion. However, the design, and the tools selected, raises a couple of points of discussion. One is that of interoperability between PIUs of one manufacturer and relays from another manufacturer. The other is related to testing.

5.1. Interoperability

The initial response from the industry to this solution was “It is not IEC61850. It is a proprietary solution. It doesn’t interoperate with equipment from other manufacturers and you/we can’t interoperate with these PIUs”. IEC61850-9-2[1] describes sampled value datasets and part of the reason why IEC 61850 is perceived as complicated is that 9-2 provides massive flexibility in publishing sampled values. To create a practical dataset requires choosing a subset of all available values which meets the needs of a particular application. Currently there are only 2 published datasets available – the UCA 9-2LE dataset[2] (which is fairly minimal in scope and is available on the UCAlug web site) and the GE HardFiber profile[3] (published in their manuals). Both datasets are fully interoperable as required by IEC 61850 and any manufacturer is free to use them in their relays and their merging units. The conclusion is that interoperability using specific profiles must be specified by end users, and equipment vendors must design products to meet this profile. Orion has obviously selected one of the available profiles. No doubt there will be more developed in the future. Possibly future instrument transformers may even support multiple datasets and just plug directly in to any relay that has implemented the desired dataset.

There is however the question of whether interoperability at the sampled values level is desirable. Full protection duplication as required in the transmission industry requires duplicating the merging units as well. Sampled value systems could then remain completely independent, as duplicate relay systems are completely independent today. Note that this raises an interesting issue if instrument transformers ever include integrated merging units – possibly multiple merging units from different manufacturers could be installed in the instrument transformer itself.

5.2. Testing

There are 2 issues related to testing when using this solution. One is the use of PIUs, as the I/O is completely separated from the relays. The other is the use of multiple zone protective relays, and the ability to isolate specific zones of protection for risk-free testing. In this installation, relays are tested by injecting secondary current and voltages directly into the PIUs. This is convenient, as the PIUs are located in close proximity to the relays, even though they are in separate rooms. The switchgear includes test plugs to accommodate this testing.

In transmission substations, where PIUs may be located outdoors hundreds of meters from the relay panels, this method is less practical, and requires the use of substitute PIUs to test relays, and field swapping tested PIUs. Orion has used the capabilities of new technology even to address testing. When using modern software-driven protection test sets which use a laptop or PC connected to the test set via Ethernet as an HMI, the test technician can simultaneously connect to both the relay and test set using the PC while usually locating himself near the PIU and test set where all the wiring is. The technician can then drive the whole procedure from his PC without having to go near either the relay or PIU. Some Orion technicians like to temporarily install a WiFi base to get connectivity to the relay from out at the circuit breaker/PIU – nice and safe.

Testing multiple zone relays is the more challenging testing issues. The method previously described of injecting currents and voltages directly into the PIUs is workable during commissioning of the station. During routine testing, however, this is difficult, as multiple relays see the data from the same PIU. In this case, a substitute PIU may be used to test a relay. For example, the multiple zone feeder relay is disconnected from all PIUs or from a specific PIU. The relay is then connected (by patching a fiber at the patch panel) to a substitute PIU wired to a test set, and zones of protection are tested without risk of tripping an in-service feeder. (All contact I/O is now part of the substitute PIU.) Disconnecting the multiple zone feeder relay from the PIUs doesn't diminish protection: the bus differential relay is still in service, and still protects the feeders.

5.3. Reliability

This new distribution substation protection system design provides obvious reliability for protective relay functions. The multi-feeder protection relay backs up the bus protection relay, and the bus protection relay backs up every feeder. However, sharing one PIU for every two feeders results in a common mode of failure for the feeders: if one PIU fails, protection is lost for two feeders. Orion has decided that sharing PIUs between feeders lowers the total project cost while maintaining an acceptable level of risk for this design. The backup overcurrent protection at the 11kV main bus breaker will eventually clear feeder faults. A failed PIU will be alarmed, and can quickly be replaced as all field wiring is connectorized.

To increase reliability by eliminating common modes of failure, a PIU may be installed for each feeder. To further increase reliability, these PIUs may be shared between feeders, and operated in a redundant fashion, as in Figure 13. For example, PIU 3 is connected in an identical fashion to the Orion design: wired to CTs from Feeders 111 and 112, and wired to the circuit breakers for these same feeders. PIU 5 is also wired to the CTs from Feeders 111 and 112 (in series with PIU 3), and wired to the circuit breakers for these same feeders (in parallel to PIU 3). The Multi-feeder protection relay and the Bus relay will then use these PIUs in a redundant fashion. PIU 3 will be the primary PIU for Feeder 111, and the redundant PIU for Feeder 112. PIU 5 will be the primary PIU for Feeder 112, and the redundant PIU for Feeder 111. On failure of one PIU, the protection immediately, on a sample-by-sample basis, swaps over to the other PIU, increasing reliability over conventional schemes for the cost of two additional PIUs.

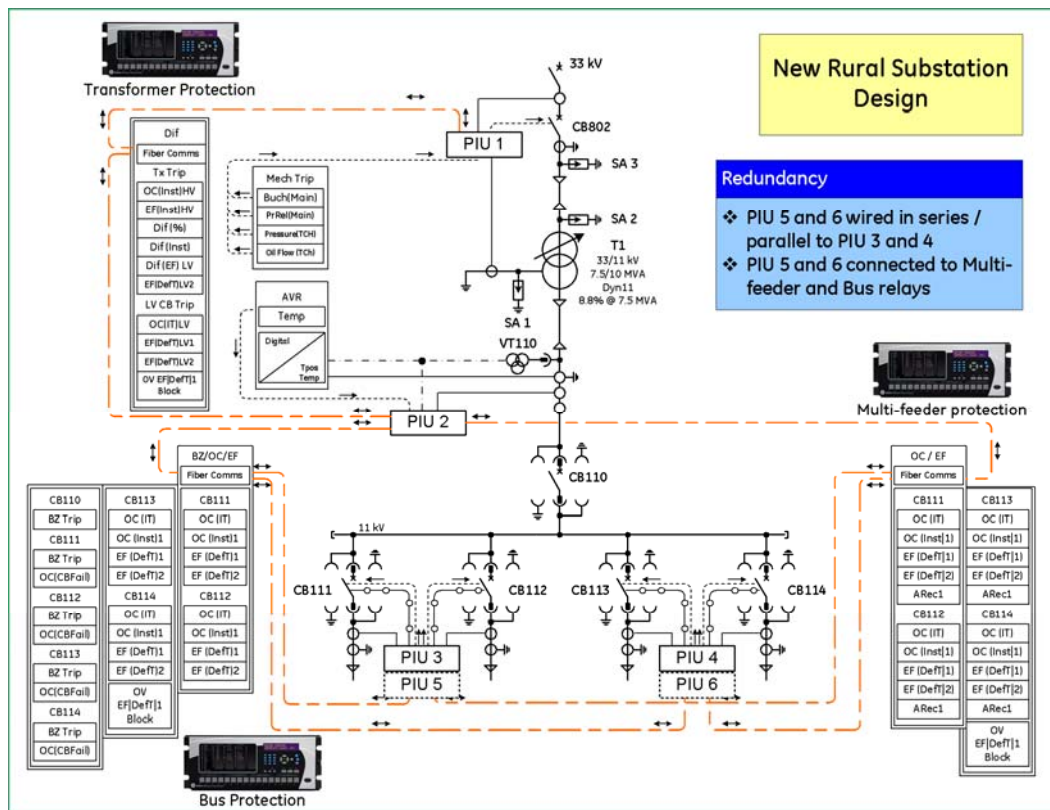

Figure 13: Reliability through redundant PIUs

6. Conclusions

IEC 61850 has evolved into a very sophisticated and complicated standard. The really big question to answer about whether to use IEC61850 is: What problem(s) are you trying to solve with this technology? This example has taken IEC 61850 and designed a solution (which does comply with the standard) to address specific business and engineering problems that face utilities and not just to match an esoteric vision of what IEC 61850 is supposed to be. In the design presented above, this solution solves or mitigates a number of problems that are faced when designing substation control and protection schemes, in terms of lifecycle and lifecycle costs, safety, design and installation, resource utilization, and economics.

7. References

- [1] IEC International Standard "Communication networks and systems in substations - Part 9-2: Specific Communication Service Mapping (SCSM) - Sampled values over ISO/IEC 8802-3", IEC Reference number IEC/TR 61850-9-2:2004(E), IEC, Geneva, Switzerland.
- [2] "Implementation Guideline for Digital Interface to Instrument Transformers using IEC 61850-9-2", UCA International Users Group, Raleigh, NC, USA.
- [3] HardFiber System Instruction Manual, GE Publication GEK-113500A.

Biographies

Rich Hunt is a Market Development Leader with GE Digital Energy, focusing on IEC 61850 solutions and strategies for protection and control systems. Rich has over 25 years' experience in the electric power industry with both utilities and solution providers. Rich earned the BSEE and MSEE from

Virginia Tech, is a Senior Member of IEEE, a member of the Main Committee of the IEEE Power System Relaying Committee, and is a registered Professional Engineer.

John Coursey is currently Technical Manager, Network Infrastructure with Orion New Zealand, Christchurch, responsible for network architecture, protection and control equipment, new product evaluation and the supervision of technical training. He began his career with the New Zealand State Hydro where he gained key roles in commissioning new equipment at various major substations leading on to thermal power station work where electronics started to be introduced including transmission line relays. He then joined the power station erection team in the Upper Waitaki hydro scheme, which was one of the first with full remote control and complex canal management. More recently he joined South Power which eventually became Orion New Zealand. Problem solving, finding out how things work, network configuration, protection design, new technology and sharing my knowledge have been the highlights of my job.

Stephen Hirsch is currently Control & Protection Systems Development Manager with Orion New Zealand, Christchurch, responsible for the development of communications, control and protection systems. He has worked in the Electricity Industry for over 20 years with experience initially with the NZED in hydro design and more recently in the distribution industry with the Central Canterbury Electric Power Board, Southpower and Orion New Zealand. He has a particular interest in digital protection systems, network automation, SCADA and communications systems.