

Settings Considerations for Distance Elements in Line Protection Applications

Bogdan Kasztenny
Schweitzer Engineering Laboratories, Inc.

Revised edition released September 2021

Previously presented at the
74th Annual Georgia Tech Protective Relaying Conference, April 2021

Originally presented at the
74th Annual Conference for Protective Relay Engineers, March 2021

Settings Considerations for Distance Elements in Line Protection Applications

Bogdan Kasztenny
Schweitzer Engineering Laboratories, Inc.

Abstract—This paper considers reach setting calculations for distance protection elements. The underreaching directly tripping application (Zone 1) is the focus of the paper, but the overreaching (Zone 2) and blocking (reverse zone) applications are discussed too. The paper starts with general application considerations including instrument transformer accuracy, line impedance data accuracy, relay steady-state and transient accuracy, line mutual coupling, resistive faults, infeed, and several others. It then re-examines the general considerations as they apply to weak systems and introduces additional considerations including ground potential rise, voltages induced in secondary voltage cables, and voltage transients from capacitively coupled voltage transformers. The paper explains why distance protection applications in weak systems face additional challenges, provides a brief explanation of typical approaches to distance element design that alleviate some of the issues, and lists application recommendations for the users. The paper also introduces a new definition for the source-to-line impedance ratio to allow unambiguous specification and more informed application of Zone 1 ground and phase distance elements in weak systems.

I. INTRODUCTION

Distance elements are a workhorse of line protection. They are used for direct tripping (Zone 1), in directional comparison pilot schemes, and in step distance protection schemes. They provide primary line protection as well as backup for a range of failure conditions, including momentary unavailability of line current differential schemes due to channel or timing problems.

A distance protection element maintains constant reach – at least under ideal conditions – irrespective of the fault current level. This key attribute makes distance elements superior to overcurrent elements (the reach of an overcurrent element is highly variable and depends on system strength and fault resistance). To maintain a constant reach, a distance protection element uses both voltage and current and responds to an apparent impedance. Under ideal conditions, the apparent impedance is proportional to the geometrical distance between the relay and the fault, allowing the distance elements to reach up to the intended point along the power line but not farther.

The ability to maintain a constant reach makes the distance element easy to set. The distance element reach can be selected in proportion to the positive-sequence line impedance. An underreaching zone (Zone 1) is set short of the remote line terminal(s) with a security margin; overreaching zones are set to reach beyond the remote terminal(s) with a dependability margin; a reverse-looking blocking zone is set to coordinate with the relay at the opposite end of the line. In this ideal scenario, distance elements can be set without performing

short-circuit studies or gathering and processing much data, except for the instrument transformer ratios and the line impedance.

Real-life applications, however, encounter challenges that complicate setting selection for distance elements as compared with a textbook application for a two-terminal line connected to two equivalent sources. This paper reviews these challenges in detail and provides recommendations.

Applications of distance elements in weak systems face additional security and dependability challenges. The topic is covered in literature but only sparsely and mostly as it relates to the combination of weak systems and capacitively coupled voltage transformer (CCVT) transients. The difference between electrical line length and geometrical length is not well understood. The definition of the source-to-line impedance ratio (SIR) is open to interpretation and does not fully reflect the complexity of distance element applications in weak systems. Arbitrary SIR values are often quoted in the literature as limits for distance element applications. Sources of error other than CCVT transients are too often neglected. Most papers cover the topic not from the application (user) perspective but from the Zone 1 distance element design (manufacturer) perspective. This paper is a comprehensive review of distance element applications in weak systems.

The paper is organized as follows:

- Section II reviews the distance element operating principle. The material is presented without going into unnecessary detail, in a form that is applicable to any relay technology (microprocessor-based, static, or electromechanical) and any operating characteristic (mho or quadrilateral). The section provides a refresher on the importance of the distance element operating signal and shows how to use it for in-depth analysis of distance element operation.
- Section III reviews general setting recommendations for underreaching (Zone 1) distance elements, including instrument transformer errors, uncertainty of line impedance data, steady-state and transient relay accuracy specifications, mutual coupling, and resistive faults. The section also discusses applications of quadrilateral distance elements and explains the importance of not exceeding a certain ratio between the resistive reach and the reactive reach.

- Section IV derives and analyzes the voltage, current, and distance element operating signal as functions of the SIR. This section provides an intuitive and unambiguous definition of the SIR, and it explains how to calculate the SIR by using a short-circuit program. The section provides a thorough explanation of why and how weak systems affect distance elements.
- Section V explains factors that disproportionately impact the application of underreaching (Zone 1) distance elements in weak systems, including ground potential rise, stray voltages induced in secondary voltage cables, relay and instrument transformer steady-state accuracies, high fault currents magnetically coupled to the protected line, the impact of CCVT transients, and transient accuracy of the Zone 1 distance elements. This section explains differences between electromechanical and microprocessor-based relays with respect to CCVT transients and weak system applications.
- Section VI provides a list of recommendations for setting the underreaching (Zone 1) distance elements in weak systems.
- Section VII considers reach settings for overreaching distance elements and elements that coordinate with one another, such as in directional comparison pilot schemes.

II. DISTANCE ELEMENT BASICS

Let us introduce the distance protection element with enough detail to derive and support the conclusions and recommendations of this paper but without going into implementation or advanced design concepts. Many papers and books explain distance protection principles and distance element design in detail [1] [2].

A distance protection element provides a constant reach on the apparent impedance plane (Fig. 1).

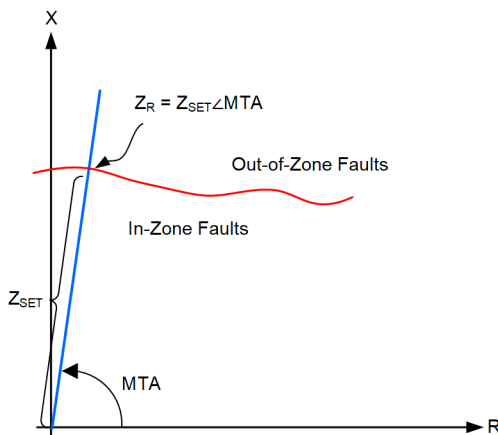

Fig. 1. Definition of distance element reach.

Impedance value Z_R is a relay setting and defines the element reach. A distance element measures a loop current (I)

and a loop voltage (V) and derives the following operating signal:

$$S_{OP} = I \cdot Z_R - V \quad (1)$$

The element compares the operating signal with a polarizing signal (S_{POL}). If the two signals are approximately in phase, the fault is internal to the zone of protection and the element operates. Otherwise, the fault is external to the zone of protection and the element restrains. Different choices of the polarizing signal yield different operating characteristics with different properties. Mho and reactance are the two distance element characteristics in common use.

A distance relay can derive the distance element operating signal (1) as an instantaneous signal (a time-domain approach) or as a phasor through band-pass filtering (a frequency-domain approach). For analysis, let us use phasors to represent the distance element operation, regardless of a particular relay design. A distance element operates when:

$$|\angle(S_{OP}, S_{POL})| < 90^\circ \quad (2)$$

For decades, various relay technologies have derived and compared the operating and polarizing signals differently. An electromechanical distance scheme may use a replica impedance to obtain the IZ term, a summing voltage transformer to obtain the operating signal (1), and a cylinder-type relay with two quadrature coils excited with the operating and polarizing signals to implement (2). A static distance relay may use a replica impedance to obtain the IZ term, a summing amplifier to obtain the operating signal (1), and a coincidence timer to determine if the operating and polarizing signals coincide (have the same polarity) for a quarter of a cycle or more as per (2). A microprocessor-based relay may use (2) and execute it directly in the code, or it may use (2) and derive an equivalent numerical formula that is more efficient for real-time execution.

All those implementations and variants have one thing in common: the distance operating signal (1), historically referred to as an IZ-V (“eye-zee/zed-minus-vee”) term. The IZ-V term allows us to explain many aspects of distance protection operation, especially applications in weak systems and the impact of transients and interfering signals.

Different polarizing signals in (2) yield different operating characteristics.

A mho distance comparator uses relay voltage for polarizing and obtains a circular characteristic (Fig. 2). The polarizing voltage can be the loop voltage (self-polarized mho), the voltage of the healthy phase(s) (cross-phase-polarized mho), the positive-sequence voltage, the pre-fault voltage (memory-polarized mho), or a combination of these options (the positive-sequence voltage with a decaying memory [3], for example).

A reactance distance comparator (a part of the quadrilateral distance element) uses current for polarizing and obtains a straight-line separation between the in-zone and out-of-zone fault regions on the apparent impedance plane. The element shifts the current by the line impedance angle or by 90 degrees

to obtain the reactance line, as in Fig. 2. Preferably, the phase of the polarizing current should inform the element about the phase of the voltage at the fault location. The polarizing current choices are the loop current, the negative-sequence current, the zero-sequence current, an incremental current, or a combination of these options. Polarizing the reactance element with a sequence current is beneficial for resistive faults (see Section III) and is sometimes referred to as adaptive polarization [1].

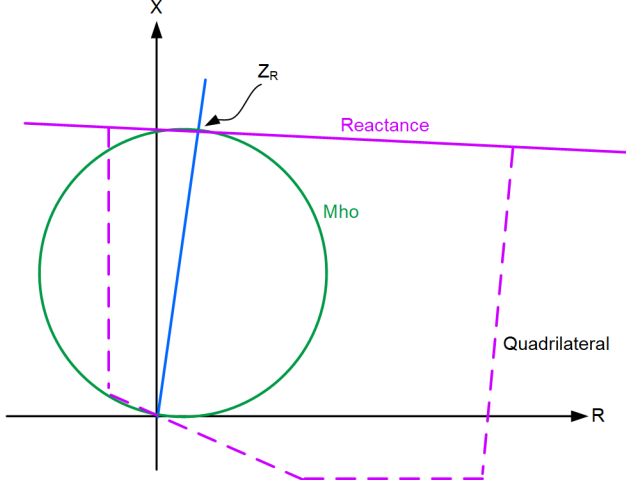

Fig. 2. Different distance element polarizing signals provide different operating characteristics.

A practical distance element logic involves more than just mho or reactance comparators. It includes a faulted-loop selection logic, directional supervision, resistive blinders, switch-off-transient security logic, overcurrent supervision, polarizing logic, and so on. However, the mho and reactance comparators are at the heart of any distance element because they determine if the fault is internal or external with respect to the reach setting. All the other subsystems in the distance element logic support these two distance-sensing comparators. The mho and reactance comparators, in turn, use the $IZ-V$ term (1), and therefore the $IZ-V$ signal is essential to the operation of any distance element.

When a relay designer implements (1) and (2), the $IZ-V$ term may become invisible. This can make the designers and users unaware of the importance of the $IZ-V$ term, and it may deny them a powerful tool for analyzing distance elements. Let us review the following example to make this important point.

Expression (2) can be written as follows:

$$\text{Re}(S_{OP} \cdot S_{POL}^*) > 0 \quad (3)$$

In (3), Re is the real part of a complex number and $*$ stands for a complex conjugate.

Substituting (1) into (3), we obtain:

$$\text{Re}((I \cdot Z_R - V) \cdot S_{POL}^*) > 0 \quad (4)$$

Rearranging (4), we obtain:

$$\text{Re}(I \cdot Z_R \cdot S_{POL}^*) > \text{Re}(V \cdot S_{POL}^*) \quad (5)$$

As Fig. 1 illustrates, the reach impedance Z_R has a magnitude of Z_{SET} (the reach setting) and an angle of MTA (the element maximum torque angle):

$$Z_R = Z_{SET} \angle MTA \quad (6)$$

Substituting (6) into (5), we obtain:

$$Z_{SET} \cdot \text{Re}(I \cdot 1 \angle MTA \cdot S_{POL}^*) > \text{Re}(V \cdot S_{POL}^*) \quad (7)$$

We solve (7) and obtain:

$$\frac{\text{Re}(V \cdot S_{POL}^*)}{\text{Re}(I \cdot 1 \angle MTA \cdot S_{POL}^*)} < Z_{SET} \quad (8a)$$

Expression (8a) holds true if the following condition is also true:

$$\text{Re}(I \cdot 1 \angle MTA \cdot S_{POL}^*) > 0 \quad (8b)$$

Condition (8b) is a part of the mathematical solution of (7). From an engineering perspective, (8b) is a directional element polarized with S_{POL} that uses the loop current as the operating signal and the distance element MTA as the directional maximum torque angle.

The left side of (8a) is a scalar apparent impedance, and it allows numerical optimization by calculating the scalar value once and comparing it multiple times with the reach settings of several distance protection zones as follows:

$$m = \frac{\text{Re}(V \cdot S_{POL}^*)}{|Z_1| \cdot \text{Re}(I \cdot 1 \angle MTA \cdot S_{POL}^*)}, m < m_0 \quad (8c)$$

Where m is the per-unit distance to the fault, m_0 is the zone per-unit reach, and Z_1 is the positive-sequence line impedance. Equation (8c) is often referred to as the “ m -calculation”.

Many practitioners today know distance protection only in the form of (8a) or (8c), often not realizing the need for supervision with (8b). Equation (8c) applies to both the mho and quadrilateral elements, with the S_{POL} determining the shape of the characteristic. Expressions (8) do not show an $IZ-V$ term even though they are derived from one. Instead, they effectively imply that a distance element operates based on the V/I ratio, augmented by the polarizing signal. Expressions (8a) and (8c) lack any relationship with the levels of loop voltage and current. The ratio in (8a) and (8c) is the same when the relay measures 20 V and 10 A during a fault as when it measures 1 V and 0.5 A. However, the impact of errors and interfering signals, described later in this paper, is very different in the two cases. By comparison, the distance operating signal (1) will typically have very different values for the 20 V/10 A and 1 V/0.5 A cases.

Additionally, if the angle between the polarizing signal and the current that is shifted by the MTA angle is close to 90 degrees, (8a) and (8c) approach a division by zero condition, even if the current is not small and the relay measures it reliably. Implementations that explicitly use (8a) and (8b) address this issue, but when applied as an analysis tool, (8c) becomes numerically susceptible to noise, interfering signals, and errors.

Equation (8c) is often used for analysis because it also serves as a fault-locating calculation. It allows us to verify if the fault is inside the protection zone, and it also calculates a relatively accurate fault location.

When we consider metallic faults, a distance element can be represented by a complex V/I ratio. This simplification allows us to see the impact of ratio errors in the voltage and current measurement on the impedance measurement accuracy. The percentage (δ) voltage and current errors combine as follows:

$$Z = \frac{V}{I} \rightarrow \delta Z = \delta V - \delta I \quad (9a)$$

Equation (9a) is intuitive: if the voltage reads low by 1 percent or if the current reads high by 1 percent, the measured impedance will appear low by 1 percent. If they have the same sign, the voltage and current errors mutually cancel in the ratio. The worst-case scenario occurs when the errors are of opposite signs (such as when the voltage reads low and the current reads high). Therefore:

$$|\delta Z| = |\delta V| + |\delta I| \quad (9b)$$

From the perspective of analyzing the impact of errors, interfering signals, and transients on a distance protection element, let us also remember that the loop voltages and currents are combinations of phase voltages and currents as follows.

- AG ground measurement loop:

$$\begin{aligned} V &= V_A \\ I &= I_A + k_0 \cdot (I_A + I_B + I_C) \\ k_0 &= \frac{1}{3} \left(\frac{Z_0}{Z_1} - 1 \right) \end{aligned} \quad (10a)$$

- AB phase measurement loop:

$$\begin{aligned} V &= V_A - V_B \\ I &= I_A - I_B \end{aligned} \quad (10b)$$

The ground distance measurement (10a) involves one voltage and three currents, and the phase distance measurement (10b) involves two voltages and two currents. Measurement errors in the phase voltages and currents may partially cancel in the loop voltage and current.

Before we discuss applications and setting calculations, let us list typical distance element settings. The following settings affect the distance element reach:

- The reach setting (Z_{SET}).
- The maximum torque angle (MTA). A distance relay may fix the MTA by design by using the positive-sequence line impedance (Z_1) angle, or it may allow setting the MTA independently from the line impedance angle.
- The zero-sequence compensation factor (k_0). This is an important setting for the ground distance element and is normally set to reflect the ratio of the zero- and positive-sequence line impedances as per (10a).

- The reactance polarizing current (I_{POL}). A quadrilateral distance element can make it selectable (loop current, negative-sequence current, zero-sequence current [3]), or it may use the polarizing current that is fixed by design (such as the sum of the negative- and zero-sequence currents [4]).
- The nonhomogeneity correction angle. This setting can be available in the relay to tilt the reactance line for accommodating system nonhomogeneity or for increasing security (tilt down) or dependability (tilt up).
- An overcurrent supervision threshold. This setting is typically provided to control the current level for which the element is permitted to operate.

Other design parameters, such as comparator limit angles or duration of memory polarizing, can also be provided as settings, but these settings are not the main topic of this paper.

III. GENERAL ZONE 1 SETTING CONSIDERATIONS

A Zone 1 distance element is set to underreach the remote line terminal(s) so that it can be used for direct tripping. The element security is paramount, and the dependability and speed of Zone 1 operation in a particular application are corollaries of security. We consider the Zone 1 distance element unsuitable for application if, with a secure reach setting, the zone is not dependable enough to justify the engineering cost and the residual security risk of applying the element. From this perspective, the applicability of the Zone 1 distance element is not a yes or no question but a cost/benefit consideration.

For security, the Zone 1 distance element must be set short of the remote line terminal(s) with enough margin to account for the expected errors in the entire protection system measurement chain. Setting the Zone 1 distance element is about identifying and qualifying sources of error. These errors can be classified as steady-state errors and transient errors. The distinction is important because transient errors are addressed by the relay design (relay manufacturer's responsibility), while steady-state errors must be addressed by element settings (relay user's responsibility). A short intentional delay can resolve transient errors, while steady-state errors cannot be addressed by delaying the Zone 1 distance element operation (unless the delay is long enough to provide time coordination with adjacent protection zones).

Weak systems (systems with a high SIR) exacerbate many of the conditions that affect the security of Zone 1 distance elements. This section reviews setting considerations for Zone 1 distance elements in general. Sections III, IV, and V focus on weak systems.

A. Voltage Transformer Errors

The voltage transformer ratio error directly impacts the effective reach of a distance element. From (9a) and (9b), it is evident that a 1 percent voltage error causes a 1 percent distance element reach error. For example, a voltage transformer that measures low by 3 percent would cause a distance element to overreach by 3 percent. The same

consideration applies to the relay voltage input accuracy. However, distance relays typically specify a combined voltage-current accuracy for their distance elements. As a result, the steady-state voltage accuracy of the distance relay is already factored into the Zone 1 distance element characteristic accuracy.

Protection-class voltage transformers are relatively accurate (having an error below a fraction of a percent) for measurements near the nominal voltage (a metering application). When considering a wide range of voltages (a protection application), a voltage transformer may have a ratio error in the range of 3 to 6 percent. Moreover, the claimed protection accuracy applies to voltages above a certain minimum level, such as 5 percent of the nominal voltage. The ratio error can be higher for voltages below the minimum specification level. This increased error is relevant in applications to weak systems (see Section IV). Also, voltage transformer accuracy applies when the burden (both power and power factor) and frequency are both within a certain range.

To obtain a voltage transformer ratio error value, inspect the transformer nameplate data or any specific test data you may have from the manufacturer or from in-house testing. Verify that the transformer burden complies with the range for which the transformer accuracy class applies. Make sure to follow the burden recommendations or account for an additional error. Apply burden resistors to properly load CCVTs when using microprocessor-based relays.

The phase angle errors of voltage transformers are small (such as 2 to 4 degrees) and have a negligible effect on distance element reach unless the system is weak.

You should leave a margin of about 5 percent in the Zone 1 distance element setting to account for voltage transformer errors, unless you have detailed accuracy data that would allow a smaller security margin.

B. Current Transformer Errors

Current transformer ratio error directly impacts the effective reach of any distance element. From (9a) and (9b), it is evident that a 1 percent current error causes a 1 percent distance element reach error. For example, a current transformer that measures low by 5 percent would cause a distance element to underreach by 5 percent.

Assessing current transformer errors is more complicated than assessing voltage transformer errors. You can expect a 5 to 10 percent ratio error from a typical protection-class current transformer during fault conditions. To obtain a current transformer ratio error value, inspect the transformer nameplate data or any specific test data you may have from the manufacturer or from in-house testing. Verify that the transformer burden (including secondary cables) complies with the range for which the transformer accuracy class applies, given the X/R ratio and the maximum fault current level for line-end faults.

Current transformer saturation causes current measurement errors that can be considerably higher than the nameplate ratio

errors. Consider the following in relation to current transformer saturation:

- Current transformer saturation makes the secondary current – when band-pass filtered in a distance relay – measure low and appear phase-shifted in the leading direction as compared with the ratio current. This kind of error typically results in the distance element underreaching (current appears lower than it is). However, the angle shift caused by saturation would affect the distance element operating signal (I_Z-V) and it may cause overreach in some circumstances. Current transformer saturation may also impact the accuracy of the measured sequence currents and it may affect adaptive polarizing of quadrilateral distance elements (we consider the Zone 1 quadrilateral element later in this section).
- To avoid issues related to current transformer saturation, we recommend sizing current transformers to ensure saturation-free operation during line-end faults for the duration of the backup protection fault clearing time (breaker failure protection or remote Zone 2 protection). This requirement is not difficult to meet for long lines because the line impedance limits the fault current for line-end faults. Avoiding current transformer saturation may be more difficult for geometrically short lines in strong systems.
- In dual-breaker applications, close-in external faults may jeopardize Zone 1 distance element security when the current transformer that carries the fault current away from the line zone of protection saturates. This application consideration cannot be addressed by reducing the Zone 1 distance element reach because the apparent impedance is very low for such faults. It can only be solved by using a security logic that is built into the distance element to address this specific issue or by selecting current transformers to avoid saturation for close-in external faults.

You should leave a margin of about 10 percent in the Zone 1 distance element setting to account for current transformer errors, unless you have detailed accuracy data that would allow a smaller security margin. Select current transformers to avoid saturation for line-end faults.

C. Line Impedance Data

Distance elements are designed to respond to the apparent positive-sequence line impedance ($m \cdot Z_1$) and are set by using both the zero-sequence (Z_0) and positive-sequence (Z_1) line impedances. Errors in the value of these impedances will result in distance element reach errors.

First, a distance element responds to the apparent positive-sequence impedance and is therefore set proportionally to the positive-sequence impedance of the line. A 1 percent difference in the positive-sequence line impedance leads to a 1 percent error in the distance element reach setting. A protection engineer knows the positive-sequence line impedance from calculations (line constants software) or from a direct

measurement during line commissioning. It is reasonable to assume that the impedance value can be known with an accuracy of not better than a 1 to 2 percent magnitude error and a 1 to 2 degree phase angle error.

Second, a ground distance element uses the zero-sequence line impedance (Z_0) for zero-sequence current compensation. Z_0 is affected by the ground wire(s) and the way the ground wire(s) is grounded along the line (grounded or insulated via spark gaps). Terrain resistivity and tower footing resistance also affect Z_0 . Different sections of the line may have different Z_0 values on a per-unit of length basis (rocky soil, farmland, water, etc.). Further, the Z_0 value may exhibit significant seasonal changes (wet season vs. dry season for example). Therefore, uncertainty in the Z_0 value may require adding as much as 5 percent of extra margin for the Zone 1 ground distance element setting.

An untransposed or partially transposed line will exhibit differences in the apparent impedance between the six loops of distance protection (AG through CA). Different tower styles along the line length may amplify or average out impedance value differences between distance protection loops. It is not uncommon for an untransposed line to have an impedance difference between the shortest and longest loops that is as high as 10 percent of the average impedance, with the positive-sequence impedance being in-between the extremes. When setting the Zone 1 phase distance element, consider the shortest phase-to-phase loop, and when setting the Zone 1 ground distance element, consider the shortest phase-to-ground loop. In the absence of detailed data, consider using the positive-sequence line impedance when setting the Zone 1 distance element but apply an additional margin to the reach setting (e.g., 5 percent).

Note that even a perfectly transposed line is only fully transposed between the line ends. The line section between the relay location and the fault may not be fully transposed. As a result, the apparent impedances in the six distance loops will differ to some degree for a fault near the reach point. This fact may call for applying an additional 2 to 3 percent of margin with respect to the line impedance data, even for perfectly transposed lines, especially in combination with infeed and outfeed effects in multiterminal or mutually coupled lines.

Power system frequency is another factor that affects the line impedance. A power line is a constant-inductance element, not a constant-reactance element. Typical setting calculations assume nominal system frequency and use the line reactance as the basis for selecting the reach settings. Frequency deviations decrease or increase the reactance value, and therefore make the line appear shorter or longer, accordingly. For example, at 59 Hz or 61 Hz, the line reactance is 1.7 percent greater or smaller, respectively, compared with the reactance at 60 Hz. When operated at 58 Hz during off nominal system conditions (such as islanding), the line will appear 3.3 percent shorter than its nominal length and the Zone 1 distance element would need an additional 3.3 percent margin to maintain the same level of security as during nominal frequency conditions. Distance elements are either constant-reactance or constant-inductance

elements. Analog distance relays are inherently constant-inductance relays. Microprocessor-based distance relays based on phasors are inherently constant-reactance relays unless they are designed to operate as constant-inductance relays. The constant-inductance element design maintains the same geometrical reach regardless of frequency deviations and is therefore referred to as a frequency-compensated distance element [4] [5]. When applying a Zone 1 distance element in a power system area that may become islanded and may operate at frequencies that are considerably different from nominal, inspect the distance relay specifications to learn if the element follows a constant-inductance or constant-reactance design, and apply additional margin in the latter case.

D. Relay Accuracy

The distance relay is the last component in the measuring chain, and it also impacts the overall accuracy of distance protection. It is convenient to consider the steady-state accuracy of the relay distance elements in general, separately from the transient accuracy of the Zone 1 distance element.

The steady-state distance element accuracy must be included in the setting margins, and it applies to both the underreaching (Zone 1) and overreaching (Zone 2, for example) zones. Typically, the steady-state impedance measurement accuracy is specified for the element maximum torque angle (often the same as the positive-sequence line impedance angle) and for a range of voltage and current values. Microprocessor-based relays tend to have an excellent steady-state accuracy, on the order of a fraction of a percent of error. However, when applying a distance element with 1) very low voltage values for line-end faults (weak systems), 2) very high current values (short lines in strong systems), or 3) very small values of reach settings (unfavorable combination of voltage and current transformer ratios in applications to short lines), inspect the relay specifications carefully to obtain the worst-case steady-state impedance measurement error.

Transient distance element accuracy is typically specified as a Zone 1 *transient overreach* error. The unique application of using the Zone 1 distance element for direct tripping (without time coordination or a pilot signal) makes the Zone 1 distance elements design different than all the other zone elements. Typically, the transient overreach specification applies only to Zone 1. Zone 2 distance elements are set to overreach the remote line terminal(s) and therefore the Zone 2 transient overreach is not consequential. Transients do not impact Zone 2 time-delayed elements because of the intentional time delay.

The following method of testing for transient overreach explains both the meaning and usefulness of the transient overreach distance element specification [2] [5]. We recommend testing for transient overreach by using a collection of fault cases located at the intended reach point or at the line end. These cases should sufficiently represent variability in fault conditions, especially the fault inception angle (point on wave). Reduce the reach of the Zone 1 distance element to the point (m_x) at which the element does not assert at all for any fault case, even when tested several times. Increase the reach to the

point (m_Y) at which the element asserts for all fault cases, even when tested several times (apply the fault condition for a sufficiently long time because the element will take a longer time to operate). Calculate the transient overreach as follows:

$$TO = \frac{m_Y - m_X}{0.5 \cdot (m_Y + m_X)} \cdot 100\% \quad (11)$$

Equation (11) ignores the true fault location and only reflects the difference between reach values for reliable restraining and operating. This allows separating the transient relay accuracy and the steady-state relay accuracy. A transient overreach of 5 percent means that one needs to apply a 5 percent setting margin to avoid transient overreach for line-end faults in addition to the margin that accounts for steady-state errors.

Transient overreach becomes a concern when the relay uses CCVTs for distance protection, especially in weak systems (see Section IV). Typically, protective relays claim a worst-case transient overreach value for a range of SIRs, such as 5 percent transient overreach when the SIR < 30. Some distance relay specifications publish a curve that shows the maximum allowable Zone 1 distance element reach as a function of the SIR. When reading the specification section, verify whether the transient overreach claim considers applications with CCVTs or only with magnetic voltage transformers and whether the application with CCVTs requires enabling any additional security logic for the transient overreach claim to be valid. Apply additional margin to account for the relay transient overreach based on the type of voltage transformer used, the SIR value, and the CCVT security logic inherently used by the relay logic or enabled by using a setting.

E. Superposition of Errors

Earlier in this section, we discussed several sources of errors that should be considered when selecting the Zone 1 distance element reach margin. Table I summarizes these errors.

TABLE I
BASIC ERRORS FOR ZONE 1 DISTANCE PROTECTION

Source of Error	Typical Reach Error (%)
Voltage transformers	5
Current transformers	10
Line impedance data	5 (phase distance elements) 10 (ground distance elements)
Relay steady-state accuracy	1
Relay transient accuracy	5
Total (worst-case additive)	26 (phase distance elements) 31 (ground distance elements)

When deciding on the Zone 1 distance element reach setting margin, one may assume the absolute worst-case scenario when all sources of error accumulate, such as the voltage transformer measures low, the current transformer measures high, the line impedance is overestimated, and the relay overreaches, all at the same time. For the typical error values listed in Table I, this approach would call for a 26 percent setting margin for the Zone 1 phase distance element and a 31 percent margin for the Zone 1 ground distance element (maximum reach settings of

74 percent and 69 percent of the line length, respectively). Many applications use an 80 percent setting for phase distance elements and a 75 percent setting for ground distance elements. This 20 to 25 percent margin is justified assuming that the errors in Table I partially cancel. For example, if the voltage and current transformers both measure low or both measure high by the same percentage error, the impedance measurement is not impacted at all. Also, when the current is high (fault conditions), the current transformer error tends to be negative (the current measures low). This makes the Zone 1 distance element underreach rather than overreach.

With accurate data on the sources of error, you may consider the Zone 1 distance element reach settings more assertive than at the typical 75 to 80 percent. For example, by using fault records – especially time-synchronized records from both ends of the line for external faults – you can calculate line impedances for in-service lines. Knowing the line impedances with high confidence, you may consider reducing the setting margin accordingly and increasing the reach setting to about 85 or 90 percent, especially for the phase distance elements.

F. Resistive Faults

Consider a resistive fault in Fig. 3.

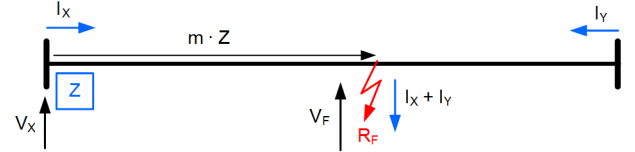

Fig. 3. Line fault with resistance.

We can write the following equation for the loop voltage and current:

$$V_X = m \cdot Z \cdot I_X + R_F \cdot (I_X + I_Y) \quad (12)$$

From (12), we calculate the apparent impedance:

$$Z_{APP} = \frac{V_X}{I_X} = m \cdot Z + R_F + R_F \frac{I_Y}{I_X} \quad (13)$$

Equation (13) shows that the expected apparent impedance ($m \cdot Z$) has the following error:

$$Z_{ERR} = R_F + R_F \frac{I_Y}{I_X} = R_F \left(1 + \frac{I_Y}{I_X} \right) \quad (14)$$

The impedance error (14) is directly proportional to the fault resistance, and therefore it is zero for metallic faults where $R_F = 0$. If the remote terminal supplies no or only a small amount of current to the fault ($|I_Y| \ll |I_X|$), the impedance error equals the fault resistance, R_F . If the remote terminal supplies current that cannot be neglected compared to the local current at the relay, the apparent impedance has an additional error proportional to the complex ratio of the remote and local currents. The higher the remote terminal current, the higher the impedance error. If the remote terminal fault current leads the local current (a load-in condition), the line representing the impedance error tilts up and creates an underreaching condition for the distance element. If the remote terminal fault current lags the local current (a load-out condition), the line

representing the impedance error tilts down and creates an overreaching condition for a distance element. See Fig. 4 for an illustration of these various scenarios. During resistive faults, the apparent impedance is always shifted right by the value of the fault resistance and additionally shifted right and up, or right and down, depending on the pre-fault power flow direction (load-in or load-out).

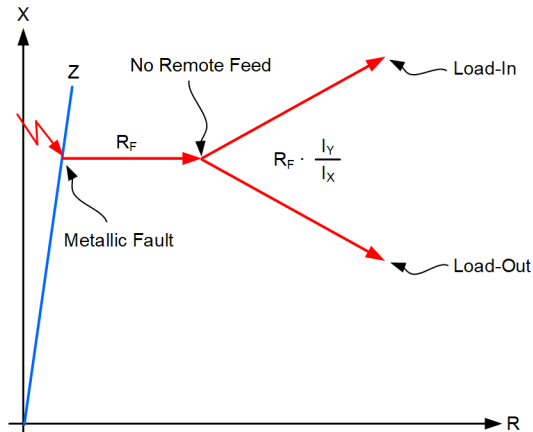

Fig. 4. Impact on the load-in and load-out conditions on the apparent impedance.

Distance element design addresses the load-out and load-in effects. Mho distance elements bend their operating characteristic down and away from the reach point to avoid overreaching (Fig. 5). The bend depends on the type of polarization and is typically sufficient to avoid overreaching of the Zone 1 distance element. Because of the mho characteristic bend, the overreaching Zone 2 distance elements may lose dependability for resistive faults located near their reach points, not only during load-out conditions but also during load-in conditions.

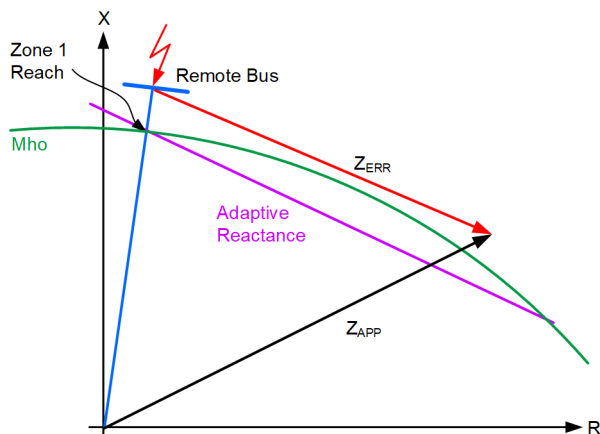

Fig. 5. Mho and quadrilateral distance element characteristics for a line-end resistive fault.

Quadrilateral distance elements may use polarizing currents selected in such a way that the reactance line of their operating characteristic tilts down and up to fight the load-out and load-in effects (see Section II). Quadrilateral distance elements may require additional settings related to the adaptive reactance comparator (selection of the polarizing current, additional reactance tilt angle for nonhomogeneous systems). Unlike mho

elements, quadrilateral elements can be designed and configured to prioritize security for underreaching applications (allow the Zone 1 quadrilateral distance elements to only tilt the reactance boundary down [4]) and dependability for overreaching applications (allow the Zone 2 quadrilateral distance elements to tilt the reactance boundary up and down [1] [3]).

Quadrilateral distance elements are, however, affected by even small phase angle errors in the polarizing current. The higher the element resistive reach, the greater the impact of the polarizing signal phase angle errors. Subsection III.I explains this phenomenon in detail and provides rules to account for the polarizing errors when setting quadrilateral elements.

In weak systems where the distance element operating signal is small, various errors may change the phase angle of the operating signal. This change has the same effect as changing the polarizing signal angle in the opposite direction. Phase errors in the distance element operating signal may lead to considerable overreach or underreach of mho and quadrilateral elements. Subsection IV.F explains this phenomenon in detail.

G. Mutual Coupling

Mutual coupling affects the reach of ground distance elements through an additional zero-sequence voltage induced in the protected line by the zero-sequence current in the line(s) sharing the same right-of-way. Depending on the direction of the zero-sequence current in the mutually coupled line(s), the additional voltage may depress the voltage at the relay location and cause overreach or it may boost the voltage at the relay location and cause underreach.

Fig. 6 shows a case of two parallel lines. The two lines terminate on the same buses and therefore are mutually coupled along the entire line length. During normal operation (Fig. 6a), the zero-sequence current splits equally between the two lines for any external fault except for faults on the parallel line. This equal current split makes it possible to compensate the ground elements for external faults, typically by modifying the zero-sequence compensation factor (k_0) to account for the extra zero-sequence voltage induced by the parallel line current [6]. However, even this simple case of two parallel lines creates exceptions that must be accounted for in relay settings. Fig. 6b shows the case of the parallel line being out-of-service; Fig. 6c shows the case of the parallel line grounded at one end; and Fig. 6d shows the case of the parallel line grounded at both ends. If the parallel line has line-side reactors or taps that connect transformers with the line-side windings grounded, the zero-sequence current flow pattern in the parallel line becomes even more complicated. The zero-sequence current and the additional voltage it induces depend on the system configuration. This makes the simple mutual coupling compensation [6] inaccurate. One can consider using SCADA to acquire the status (on/off) of the grounding points to control relay setting groups to adapt the ground distance elements accordingly. But such a solution is typically considered too complicated for the benefits it brings.

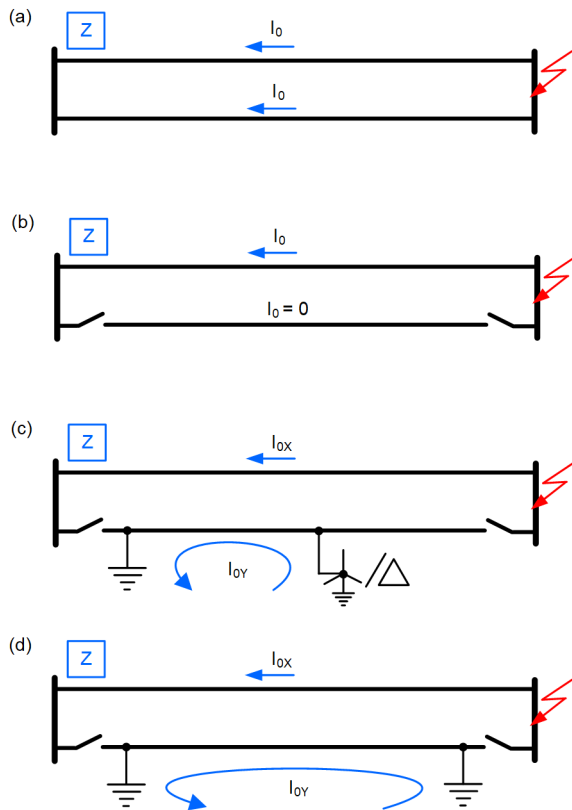

Fig. 6. Application considerations for parallel lines: (a) normal operation and (b) through (d) various out-of-service configurations.

The line right-of-way may include multiple lines, especially in highly congested urban areas, in a difficult terrain, or near power plants. Two lines may share the same towers. Towers that carry other lines may be placed in the same transmission corridor. These lines may run parallel for some distance and then diverge and terminate on different buses of the same or different voltage levels (Fig. 7). In such cases, the zero-sequence current flow may be complicated and the current in some mutually coupled lines may boost the voltage at the relay location through mutual coupling, while the current in other mutually coupled lines may depress the relay voltage.

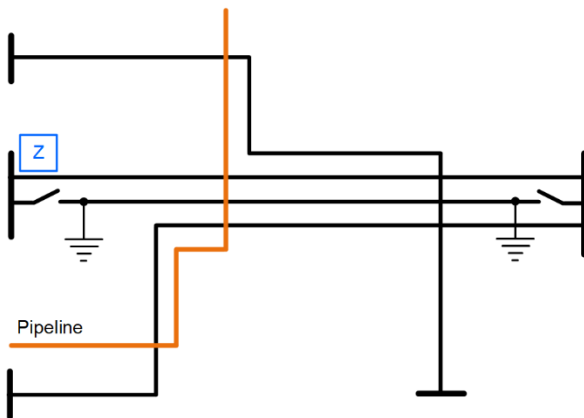

Fig. 7. Mutual coupling between many lines in a meshed network.

Water, oil, and gas pipes and railroad trucks also create zero-sequence current loops and, when located in the transmission

corridor, they further affect and complicate the ground current flow.

Preferably, the short-circuit program should model parallel lines and their grounding with reasonable accuracy. Use relay records from system faults to improve and maintain the accuracy of your short-circuit model. In applications with mutual coupling, you should use the short-circuit program when setting Zone 1 ground distance elements; follow these recommendations:

- Consider all credible contingencies, including assets in and out of service.
- When modeling out-of-service conditions for a mutually coupled line, consider it grounded and ungrounded. For out-of-service lines that operate with grounding elements connected (reactors and tapped transformers), consider them with safety grounds applied at one or both ends.
- Apply ground faults at the remote bus as well as on mutually coupled lines in the proximity of the remote bus and obtain the apparent impedances for these faults. When calculating the apparent impedance, use the same zero-sequence compensation factor that you plan on using in the relay.
- When setting Zone 1, select the smallest apparent impedance and apply a 25 percent margin to account for errors, as explained earlier in this paper.
- When setting Zone 2, select the largest apparent impedance with margin (see Section VII).

The above procedure appears complicated and seems to negate the key advantage of distance protection – the ability of the distance element to maintain a constant reach regardless of system conditions. Consider, however, that the application assumes a meshed network with complicated flow patterns of the zero-sequence currents that couple to the protected line. The distance protection element does not account for that coupling and cannot be inherently accurate as in applications without mutual coupling. Using the short-circuit program to obtain the worst-case values of the apparent impedance for the underreaching (Zone 1) and the overreaching (Zone 2) elements addresses the problem of the element reach depending slightly on system configuration.

Mutual coupling becomes a critical application factor for distance elements (both ground and phase) when the line connects to a weak terminal and at the same time mutually couples to a strong fault current path (see Subsection IV.E).

H. Infeed and Outfeed Effect in Multiterminal Lines

When a fault occurs on a multiterminal line outside of the local line section (Fig. 8), the current(s) from the other line terminal(s) creates an additional voltage across the impedance between the tap point and the fault, and by doing so, the remote current affects the local relay voltage. In two-terminal applications, the remote current affects the local relay voltage only for resistive faults. In multiterminal applications, the

remote current can affect the local relay voltage even during metallic faults.

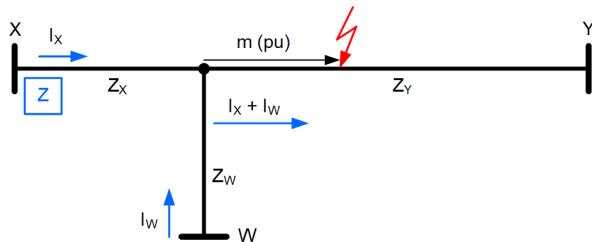

Fig. 8. Infeed and outfeed effect in a three-terminal line.

Considering the distance element loop voltage and current, we can write the following equation for the metallic fault in Fig. 8:

$$V_X = Z_X \cdot I_X + m \cdot Z_Y \cdot (I_X + I_W) \quad (15)$$

From (15), we calculate the apparent impedance:

$$Z_{APP} = \frac{V_X}{I_X} = Z_X + m \cdot Z_Y + m \cdot Z_Y \cdot \frac{I_W}{I_X} \quad (16)$$

Equation (16) shows that the expected apparent impedance ($Z_X + m \cdot Z_Y$) has the following additional error:

$$Z_{ERR} = m \cdot Z_Y \cdot \frac{I_W}{I_X} \quad (17)$$

The impedance error (17) depends on the ratio of the relay fault current (I_X) and the fault current (I_W) from the terminal connected between the local terminal and the fault location. The combination of a large remote terminal current and a small relay current magnifies the error. The farther the fault is from the tap, the higher the impedance error.

Depending on the relative phase angle between the I_X and I_W currents, the impedance error may add to the physical impedance of the line section (Z_Y) or subtract from it. When the two currents are approximately in phase (infeed), the apparent impedance (16) increases and a distance element may underreach. When the two currents are approximately out of phase (outfeed), the apparent impedance (16) decreases and a distance element may overreach. Outfeed conditions are rare, however, and distance elements typically underreach when applied to multiterminal lines.

Consider using the short-circuit program to obtain apparent impedance values for line-end faults when setting distance elements in applications to multiterminal lines. Remember to consider the breaker out-of-service condition as a valid contingency. When the breaker is open, the current is zero and the infeed or outfeed effect is eliminated. Therefore, in multiterminal applications, the Zone 1 distance element should not be set to compensate for the underreaching effect but should be set short of the remote terminal that is electrically closest to the local terminal. For example, in Fig. 8, the reach of the Zone 1 distance element at Terminal X should not exceed $|Z_X + Z_Y|$ or $|Z_X + Z_W|$, whichever is smaller.

Remember that if the line connects grounded taps, the zero-sequence current creates a form of multiterminal application for

ground distance elements: the grounding points divert the current away from the relay and change the voltage drop value between the relay and the fault (Fig. 9). Use the short-circuit program to obtain the range of apparent impedance values for ground faults at the remote terminal(s), and set the Zone 1 ground distance element reach accordingly.

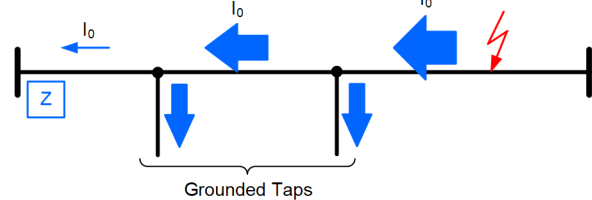

Fig. 9. Grounded taps divert the zero-sequence current away from the relay and reduce the ground distance element reach.

Typically, the grounded taps that connect loads cause distance elements to underreach (the relay measures a zero-sequence current that is lower than the average zero-sequence current along the line). However, if the taps connect generation sources or are tied to other lines, these taps may create either an infeed or outfeed effect where the impact is not limited to the zero-sequence but includes all three sequence components. Fig. 10 shows an example of feeding two transformers from taps on two parallel lines and operating their secondary windings connected in parallel to feed the load (dual-element spot network). In such cases, using the short-circuit program to set distance elements is highly recommended.

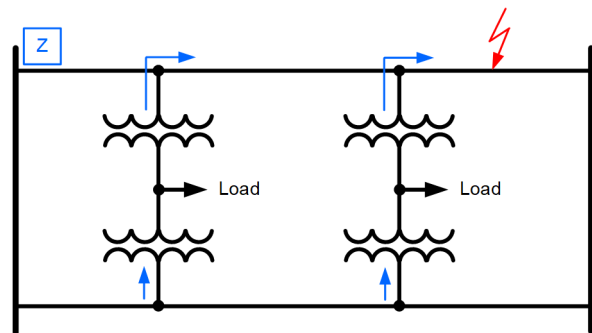

Fig. 10. Line taps that tie power sources lead to complex current flow patterns.

I. Quadrilateral Distance Element Considerations

Quadrilateral distance elements, especially if set to have a large resistive reach, are susceptible to phase angle errors in their polarizing currents. Fig. 11 illustrates this phenomenon by plotting the apparent impedance for a resistive fault during load-out conditions and showing the element reactance line tilted downward for security.

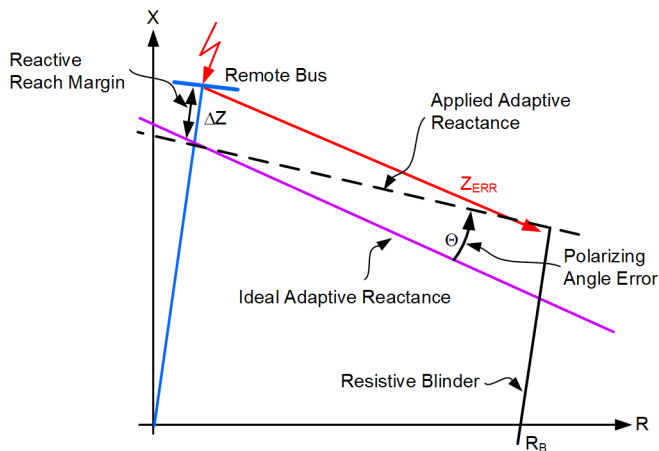

Fig. 11. Impact of phase angle errors in the polarizing current on the security of the quadrilateral distance element.

Assume an ideal polarizing current that allows an exact compensation for the load-out effect. The Z_{ERR} line and the reactance line are exactly parallel for an ideal compensation. However, assume there is a small phase angle error (Θ) in the applied polarizing current. This error (the angle difference with respect to the ideal polarizing current) can be caused by any or a combination of the following factors:

- Current transformer ratio error
- Current transformer saturation
- Line charging current
- System nonhomogeneity
- Complex resistive fault with resistance in more than one measurement loop (we explain this phenomenon at the end of this section).

The dashed line in Fig. 11 represents the effective reactance line that includes the phase angle error. If the element resistive reach (resistive blinder) is set past the R_B value in Fig. 11, the element will overreach despite having a margin of ΔZ in the reactive reach. We can write the following approximate relationship between the reactive reach margin (ΔZ), the resistive reach (R_B), and the phase angle error in the polarizing current (Θ):

$$\Delta Z > 2 \cdot R_B \cdot \sin\left(\frac{\Theta}{2}\right) \quad (18)$$

Assume m_0 is the reactive reach and r_B is the resistive reach (both in per unit of the positive-sequence line impedance). We can rewrite (18) to obtain the largest secure reactive reach, given the applied resistive reach and the phase error in the polarizing current:

$$m_0 < 1 - 2 \cdot r_B \cdot \sin\left(\frac{\Theta}{2}\right) \quad (19)$$

Fig. 12 plots (19) for a range of phase angle errors. The figure shows the maximum per-unit reactive reach (m_0) as a function of the applied per-unit resistive reach (r_B).

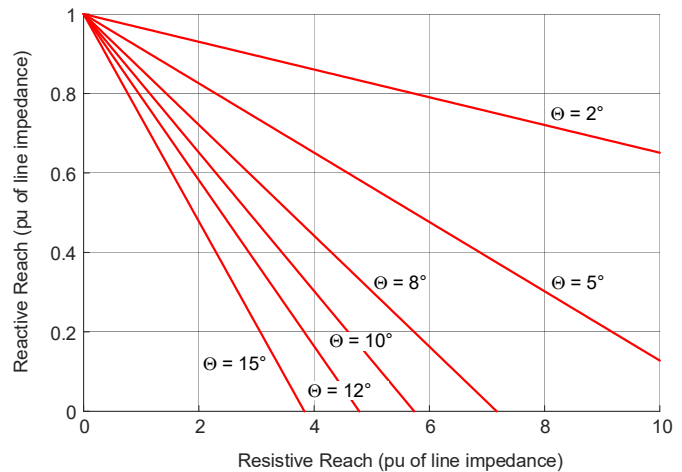

Fig. 12. Maximum per-unit reactive reach as a function of the applied per-unit resistive reach for a range of phase angle errors in the polarizing current.

Use Fig. 12 to coordinate the reactive and resistive reach values for an expected worst-case error in the polarizing current. For example, if you expected 5 degrees of polarizing error and would like to set the reactive reach to 80 percent of the line impedance, you can afford a resistive reach of about 2.3 times the line impedance. If you increase the resistive reach above this value, the Zone 1 distance element may overreach for resistive faults. Assume your objective is to apply a resistive reach as high as 4 times the line impedance. With 5 degrees of error, you can only afford a reactive reach of about 65 percent of the line impedance.

We can use (18) to find the minimum ratio between the reactive reach margin (ΔZ) and the resistive reach, as follows:

$$\frac{\Delta Z}{R_B} > 2 \cdot \sin\left(\frac{\Theta}{2}\right) \quad (20a)$$

For small angles, $\sin(x) = x$ radians. Therefore, we can further simplify (20a) and write:

$$\frac{\Delta Z}{R_B} > \Theta \cdot \frac{\pi}{180} \quad (20b)$$

For example, assuming a polarizing phase angle error of 5 degrees, we obtain $\Delta Z/R_B > 0.087$. This means that the reactive reach margin must be at least 8.7 percent of the resistive blinder, or else the element may overreach. With a resistive blinder of 4 times the line impedance, the reactive reach margin must be 0.35 times the line impedance, i.e., the reactive reach must be less than 65 percent of the line impedance (compare with Fig. 12).

Fig. 12 and (20a) and (20b) show that when the polarizing error is significant, one needs to considerably reduce either the resistive reach setting, the reactive reach settings, or both or else the Zone 1 quadrilateral distance element may overreach.

Let us finish this subsection by explaining the lesser-known sources of phase angle error in the polarizing current. First, consider the complex resistive phase-to-phase-to-ground fault shown in Fig. 13.

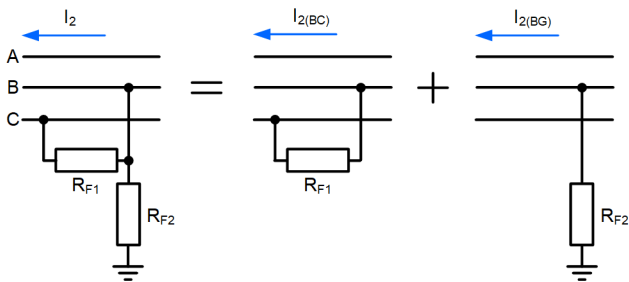

Fig. 13. A BCG fault that involves two resistances.

Depending on the values of the fault resistances R_{F1} and R_{F2} , the relay may select the BC phase distance measurement loop or the BG ground distance measurement loop. The relay may use the negative-sequence current to polarize the quadrilateral element. However, the negative-sequence current will not ensure security in this case. The fault can be considered as a superposition of two faults, as Fig. 13 illustrates. The $I_{2(BG)}$ current is the accurate polarizing signal for the BG loop during a BG fault, and the $I_{2(BC)}$ current is the accurate polarizing signal for the BC loop during a BC fault. However, when the BG and BC faults are present simultaneously, the negative-sequence current at the relay location (I_2) does not exactly represent either the angle of the current in the BC fault path or the angle of the current in the BG fault path. Regardless, if the element selects the BC or BG loop, the polarizing current I_2 will have a phase angle error with respect to the ideal polarizing signal. The presence of the BG fault path during a BCG fault affects the polarizing accuracy for the BC loop, and the presence of the BC fault path during a BCG fault affects the polarizing accuracy for the BG loop. Adaptive polarizing of the quadrilateral elements is exact only when the fault involves a single resistance, i.e., when the fault is a phase-to-ground or a phase-to-phase fault. Adaptive polarizing does not work well (will exhibit a phase angle error in the polarizing signal) during complex faults with multiple fault resistances.

A similar problem occurs for three-phase symmetrical or near-symmetrical faults (the negative-sequence current is zero or very low). Relay filter transients, current transformer ratio errors, and line unbalance (lack of perfect transposition) may create a spurious negative-sequence current that has a random phase angle. This random angle renders adaptive polarization with negative-sequence current useless. For this reason, Zone 1 quadrilateral distance elements may fall back on the mho operating characteristic during three-phase balanced or near-balanced faults.

In general, the polarizing signal of mho elements is accurate, and when combined with the circular operating characteristic, it does not create security concerns for resistive faults during load-out conditions. The polarizing signal of quadrilateral elements may be off by a few degrees for several reasons, and when combined with an extended resistive reach, it may cause considerable security concerns for resistive faults. Limiting the resistive reach in the Zone 1 quadrilateral distance element applications helps to solve this problem.

A relay design solution to the quadrilateral element polarization problem is to boost the sequence polarizing current

of the Zone 1 quadrilateral distance element by using a small positive-sequence voltage signal [4]. This voltage boost is inconsequential when the sequence polarizing current is large (and therefore accurate in terms of its phase angle), but it provides reliable polarization when the sequence current is low (and therefore it may have a less accurate phase angle).

IV. DISTANCE ELEMENT OPERATING CONDITIONS IN WEAK SYSTEMS

In this section, we calculate the relay voltage, current, and distance element operating signal for line faults in weak system applications. These calculations will allow us to identify and analyze the many sources of errors that affect distance element applications in weak systems.

A. Distance Element Operating Signals

Consider the equivalent single-phase system shown in Fig. 14. A distance element is set to have a per-unit reach of m_0 . Z_L is the line impedance. $SIR \cdot Z_L$ and E are the impedance and voltage of the equivalent source, respectively. The system is homogeneous. A metallic fault occurs at a per-unit distance (m) from the relay location. We will use the system in Fig. 14 to calculate the relay voltage (V), current (I), and distance element operating signal (S_{OP}).

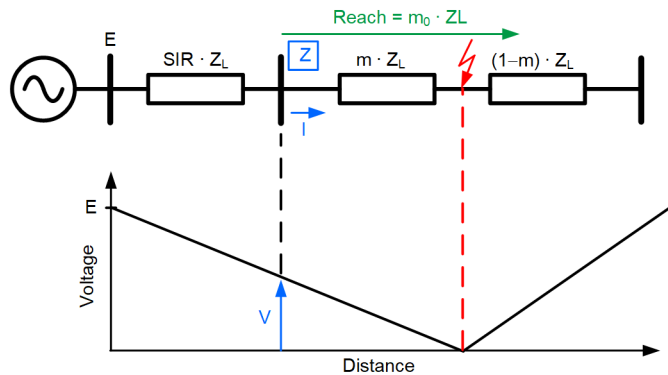

Fig. 14. Distance element voltage and current analysis.

The relay current is:

$$I = \frac{E}{Z_L \cdot (SIR + m)} \quad (21)$$

The relay voltage is:

$$V = \frac{m \cdot E}{SIR + m} \quad (22)$$

Assuming E is close to the system nominal voltage, the relay voltage in per unit of nominal is:

$$V_{PU} = \frac{m}{SIR + m} \quad (23)$$

Fig. 15 plots (23) and shows the per-unit relay voltage for line-end faults ($m = 1$ pu) as a function of the SIR (faults at the remote terminal are relevant for the security of the Zone 1 distance element).

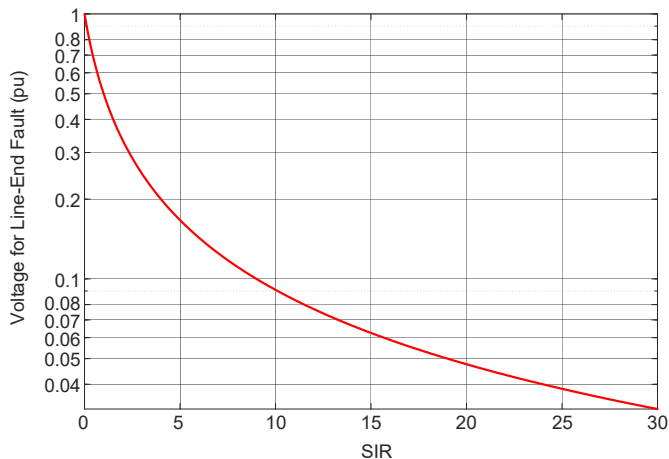

Fig. 15. Per-unit relay voltage for line-end fault as a function of the SIR.

Fig. 15 uses a semilogarithmic scale to better show the considerable reduction of the relay voltage level for line-end faults when the SIR increases to high values. For example, for an SIR of 5, the relay voltage is more than 15 percent of the nominal voltage; for an SIR of 10, the voltage is only 9 percent of nominal; and for an SIR of 30, the voltage is only 3 percent of nominal. With such low voltage levels, many sources of error may affect the voltage measured by the relay. Section V discusses these sources of error in detail.

By substituting (21) and (22) into (1), we obtain the distance element operating signal as follows:

$$S_{OP} = E \cdot \frac{m_0 - m}{SIR + m} \quad (24)$$

The per-unit distance element operating signal is:

$$S_{OP(PU)} = \frac{m_0 - m}{SIR + m} \quad (25)$$

As expected, the per-unit distance element operating signal is zero for faults located exactly at the element reach point ($m = m_0$); it is positive for in-zone faults ($m < m_0$), and it is negative for out-of-zone faults ($m > m_0$).

Fig. 16 plots the per-unit distance element operating signal as a function of the SIR of a distance element set to 80 percent of the line length ($m_0 = 0.8$) for faults at the line end ($m = 1$).

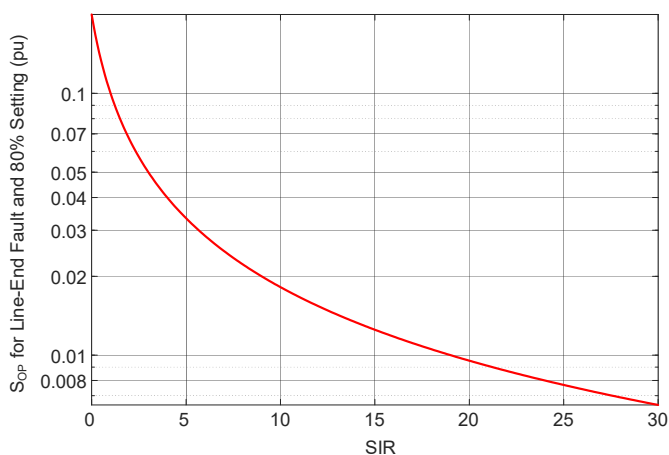

Fig. 16. Per-unit distance element operating signal as a function of the SIR (line-end fault; reach setting of 80 percent of the line length).

The plot in Fig. 16 is a distance element margin between operating and restraining conditions for a line-end fault (assuming a typical reach setting of 80 percent of the line impedance). This margin is 3.5 percent of the nominal voltage for an SIR of 5, less than 2 percent for an SIR of 10, less than 1 percent for an SIR of 20, and about 0.6 percent for an SIR of 30.

To understand the importance of Fig. 16, assume the relay measures the current (I) with a perfect accuracy, the line impedance (Z) is known with perfect accuracy, but the relay measures the voltage signal (V_{MEAS}) with a small error (V_{ERR}) as follows:

$$V_{MEAS} = V_{TRUE} - V_{ERR} \quad (26)$$

Using (26), we calculate the measured distance element operating signal as it relates to the true distance element operating signal:

$$\begin{aligned} S_{OP(MEAS)} &= IZ - V_{MEAS} = \\ &IZ - (V_{TRUE} - V_{ERR}) = \\ &IZ - V_{TRUE} + V_{ERR} = \\ &(IZ - V)_{TRUE} + V_{ERR} = \\ &S_{OP(TRUE)} + V_{ERR} \end{aligned} \quad (27)$$

Equation (27) means the error in voltage adds directly to the true distance element operating signal (the voltage error that decreases the measured voltage increases the operating signal). On a per-unit basis, we can write:

$$S_{OP(PU MEAS)} = S_{OP(PU TRUE)} + V_{PU ERR} \quad (28)$$

Equation (28) and Fig. 16 explain the root cause of the challenge of applying distance elements in weak systems:

- The voltage error adds directly to the operating signal of the distance element, while at the same time
- The operating signal is very small when the SIR is high.

Even a small error in the voltage can considerably impact the operating signal, up to and including inverting its polarity compared with true polarity with respect to the polarizing signal. As a result, an external fault can appear as internal and vice versa.

Consider a remote line-end fault for an SIR of 20. Based on Fig. 16, the distance element operating signal is less than 1 percent of the nominal voltage. An error in the measured voltage equal to or higher than 1 percent of the nominal voltage can invert the polarity of the operating signal and cause the element to misoperate.

We can further illustrate the impact of voltage errors in applications with a high SIR by using a voltage profile, as shown in Fig. 17. In applications with a low SIR, the apparent zero-voltage point (or the fault point, F) does not move much relative to the line length because of voltage measurement errors (Fig. 17a). In applications with a high SIR, however, even a small error in voltage significantly moves the apparent zero-voltage point (F) relative to the line length (Fig. 17b).

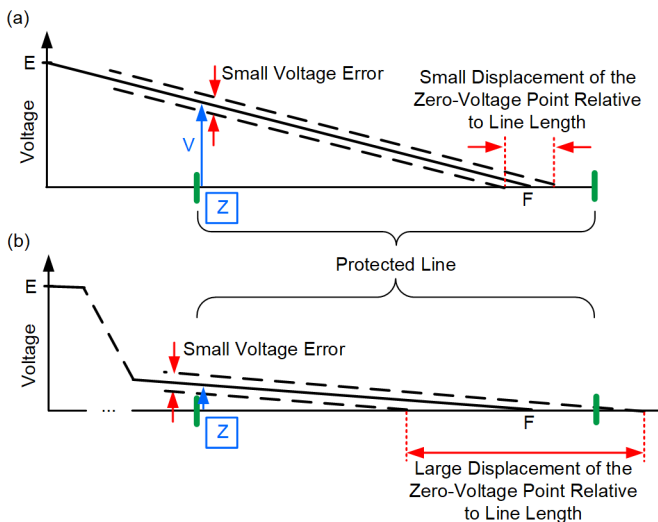

Fig. 17. Impact of the voltage error on the location of the zero-voltage point in the voltage profile: (a) low SIR and (b) high SIR.

Let us broaden our analysis to include overreaching distance elements and consider the dependability of distance elements under high SIR conditions. We can use (25) to calculate the per-unit distance element operating signal for faults located 20 percent short of the distance element reach point. Let us calculate the per-unit operating signal, assuming a remote line-end fault ($m = 1$) and the typical reach of 120 percent for overreaching Zone 2 applications ($m_0 = 1.2$):

$$S_{OP(PU)} = \frac{1.2 - 1}{SIR + 1} \quad (29)$$

Fig. 18 plots (29) for varying SIR values. The figure shows a very small operating signal for high SIR values. For example, for an SIR of 20, the operating signal is less than 2 percent of the nominal voltage. Therefore, an error of just 2 percent of the nominal voltage can cause the overreaching element to lose dependability. We can also understand the dependability challenge from Fig. 17b. If the relay measures the voltage higher than the true value, the apparent zero-voltage point (F) of the voltage profile appears farther away, causing the distance element to underreach and potentially lose dependability.

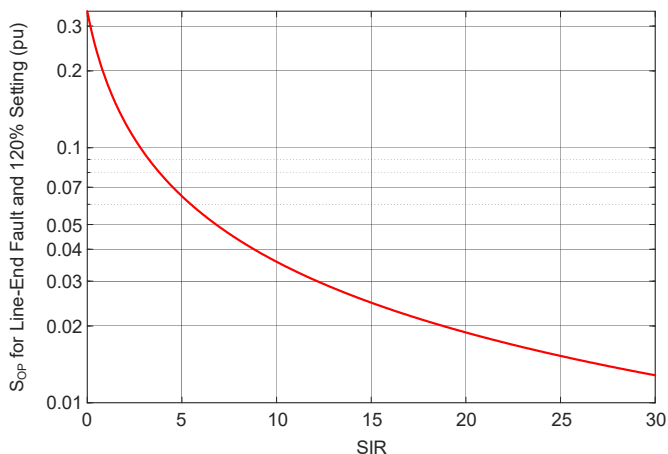

Fig. 18. Per-unit distance element operating signal for line-end faults inside the Zone 2 distance element reach per (29).

B. Defining the SIR

Fig. 14 is commonly used to conceptualize the SIR. It shows a single-phase model of a system with one impedance value characterizing the protected line and another impedance characterizing the system. The model assumes the line and system impedances have the same angle (the system is homogeneous) and the SIR is commonly understood as the ratio of their magnitudes. In real-life situations, this simplification only applies to three-phase balanced faults in homogeneous systems.

During single-phase-to-ground faults, the phase-to-ground voltage at the relay location is a function of the positive- and zero-sequence line impedances and the positive-, negative-, and zero-sequence source impedances (in general, the negative- and positive-sequence impedances of synchronous generators are not equal). During phase-to-phase faults, the phase-to-phase voltage at the relay location is a function of the positive-sequence line impedance and the positive- and negative-sequence source impedances.

The operating conditions, and thus the SIR values, can be different for ground distance elements and phase distance elements. For example, a line that is fed from a weak source but terminated on a bus that connects grounding elements (transformers and autotransformers) may have an SIR for phase faults that is much higher than the SIR for ground faults (the source zero-sequence impedance is lower than the positive-sequence impedance).

In general, the following five complex numbers determine the distance element operating signal for line-end metallic faults: $(Z_0, Z_1, Z_2)_{SYS}$ and $(Z_0, Z_1)_{LINE}$. It is evident that representing these five complex numbers by a single ratio is an oversimplification. It also often leads to confusion, such as the role of parallel paths in determining the SIR, the difference between the electrical and physical length of the line, or the impact of system nonhomogeneity on the SIR [7].

We advocate using (23) to define the SIR. If V_{PU} is the distance element loop per-unit voltage magnitude (phase-to-ground for the ground distance elements, $V_{PU(LG)}$, and phase-to-phase for the phase distance elements, $V_{PU(LL)}$) for a metallic fault at the remote line end ($m = 1$), then we can define the ground (G) and phase (P) SIR by solving (23) as follows:

$$SIR_G = \frac{1 - V_{PU(LG)}}{V_{PU(LG)}} = \frac{1}{V_{PU(LG)}} - 1 \quad (30a)$$

$$SIR_P = \frac{1 - V_{PU(LL)}}{V_{PU(LL)}} = \frac{1}{V_{PU(LL)}} - 1 \quad (30b)$$

Use (30a) and (30b) in conjunction with the short-circuit program and follow these steps to determine the phase and ground SIR values:

Step 1. Place a metallic single-phase-to-ground fault at the remote bus and calculate the per-unit phase-to-ground voltage magnitude at the relay location.

Step 2. Calculate SIR_G by using (30a).

- Step 3. Repeat Steps 1 and 2 for a range of system conditions and contingencies and obtain a range of SIR values applicable to the ground distance elements.
- Step 4. Place a metallic phase-to-phase fault at the remote bus and calculate the per-unit phase-to-phase voltage magnitude at the relay location.
- Step 5. Calculate SIR_P by using (30b).
- Step 6. Repeat Steps 4 and 5 for a range of system conditions and contingencies and obtain a range of SIR values applicable to the phase distance elements.

For example, if the phase-to-ground voltage magnitude at the relay location for a remote line-end single-phase-to-ground fault is 0.081 pu of the phase-to-ground nominal voltage, the SIR value for the ground distance elements is 11.3. In the same system, the phase-to-phase voltage at the relay location for a remote line-end phase-to-phase fault may be 0.053 pu of the phase-to-phase nominal voltage. The SIR value for the phase distance elements is therefore 17.9. In this example, the zero-sequence system is stronger than the positive-sequence system. As a result, the system maintains a higher faulted-loop voltage during ground faults and the SIR is lower (more favorable) for ground distance elements than for phase distance elements.

Defining the SIR by using (30a) and (30b) allows application of the model in Fig. 14 (a homogeneous voltage divider) to draw conclusions on how the SIR affects the relay voltage and the distance element operating signal. Additionally, using the short-circuit program to calculate the SIR allows factoring in not only system nonhomogeneity but also mutual coupling, line unbalance, transient and subtransient response of synchronous generators, fault response of wind and inverter-based generators, and so on. For example, in applications with synchronous generators, the SIR value is lower in the first few milliseconds of the fault and it slightly increases with time as the subtransient and transient current components decay.

V. ZONE 1 CONSIDERATIONS IN WEAK SYSTEMS

Section III reviewed general considerations for Zone 1 distance elements in line protection applications. All these considerations apply in weak systems as well, i.e., when the SIR value is high or – to state it more precisely – when the distance element operating signal for line-end faults is low (Section IV). Moreover, many of the Section III considerations are exacerbated in applications to weak systems. This section reviews these considerations in detail.

A. Instrument Transformer and Relay Steady-State Accuracies

The general rule that each percent of voltage or current error adds one percent to the distance element reach error applies in weak systems as well. However, remember that in weak systems, the voltage transformers and voltage inputs of the relay work with very low voltages during line-end faults. For example, the relay voltage is less than 5 percent of nominal for an SIR over 20 (Fig. 15). Consult the specifications of the voltage transformer and the relay for the voltage measurement

accuracy at such low voltage levels. Expect larger percentage errors at low voltage levels and apply a larger margin in the Zone 1 distance element reach setting.

Zone 1 distance elements have a high susceptibility to errors when the distance operating signal is very low. Current transformer saturation affects the IZ portion of the IZ–V term and may play a role when the IZ–V signal is low. Sizing current transformers to avoid saturation for line faults in weak systems is not difficult. It is good practice to use current transformers that do not saturate for at least one time-step of protection coordination (300 to 500 ms). This ensures that external faults are cleared before a current transformer saturates and causes errors in the current that may result in Zone 1 distance element misoperation.

B. Voltages Induced in Secondary Voltage Cables

As an example, consider that the distance element operating signal for an SIR of 20 and a reach setting of 80 percent is below 1 percent of the nominal voltage (Fig. 16). A voltage error of a fraction of 1 percent can change the operating signal considerably and lead to an overreach. At the 66.4 V secondary nominal phase-to-ground voltage, 0.5 percent of error is only 330 mV. You can expect the primary or secondary currents to induce this level of secondary voltage in the voltage secondary cables through mutual coupling. This is especially likely if you use unshielded voltage cables and the secondary cables are laid out parallel to the primary conductors over relatively long distances in the switchyard.

Normally, the voltage secondary cables use a four-wire connection. As a result, both the phase-to-ground and phase-to-phase voltages are delivered from the VT to the relay in a differential manner. The secondary phase conductors are typically included in the same multiwire cable, and therefore their distances to the source of the problem are practically identical. As a result, the same voltage is induced in all three phase conductors and the fourth neutral conductor. This means the errors in the phase-to-ground and phase-to-phase voltages cancel. However, if the control cables from the individual phase VTs to the marshaling cabinet are relatively long, the induced voltages may not cancel and some stray voltages may be superimposed on the true secondary voltages. These errors are more likely to affect the ground distance elements.

Consider the following risk factors when setting the ground distance elements in weak systems:

- Lack of shielding of secondary voltage cables; secondary current cables located in the same conduit.
- Questionable quality of grounding of the secondary voltage circuit and suspected but unresolved multiple (unintentional) grounds in the secondary voltage circuit that create current loops and associated voltage drops between the voltage transformer and the distance relay.
- Secondary voltage cables laid out parallel to primary conductors in the switchyard, especially the section between the VTs and the marshaling cabinet.

Typically, substation design and layout attempt to minimize signals induced in the control cables. When you have a choice, apply high tap secondary voltage output from the voltage transformer to improve the signal-to-noise ratio. In weak system applications, evaluate the risk of having additional voltage induced in the voltage secondary cables and reduce the reach accordingly or refrain from using the ground distance elements. If you cannot trust your secondary wiring to deliver the phase-to-ground voltage signals from the voltage transformer with enough accuracy given the ground SIR value (SIR_G), then you should consider avoiding the use of Zone 1 ground distance elements.

Using merging units to acquire the voltage signal directly at the location of the voltage transformer, or using non-conventional voltage transformers, may improve the measurement accuracy of the very low voltages and ease the Zone 1 application constraints in weak systems. However, consult the nonconventional voltage transformer and relay specifications to understand the end-to-end accuracy before applying Zone 1 distance elements in weak systems.

C. Ground Potential Rise

Voltage transformers measure the potential of line conductors with respect to the substation ground, not with respect to the remote (ideal) earth, see Fig. 19. Ground potential rise (GPR) is the substation ground voltage relative to the remote earth. The substation grounding system is designed to limit GPR to a small value, ideally on the order of several hundred volts. Normally, the zero-sequence current sinks into the substation ground and lifts the substation ground potential relative to the remote earth. By doing so, it makes the voltage transformers measure low. This in turn leads to a distance element overreach rather than an underreach.

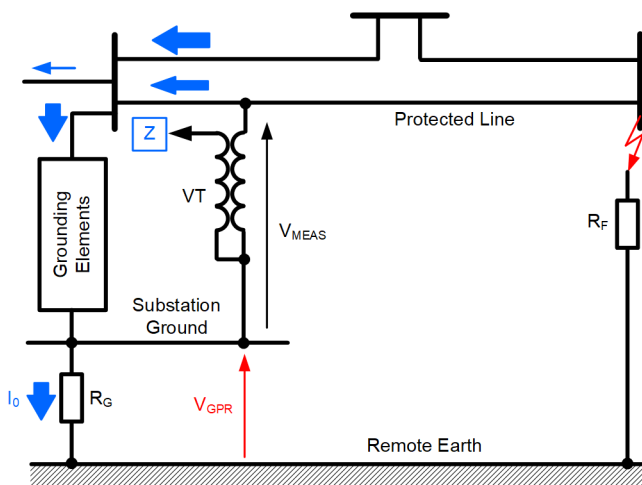

Fig. 19. Impact of ground potential rise on the measurement of phase-to-ground voltages.

Assume a moderate GPR of 0.5 kV as an example. In distance element applications to strong systems, the GPR is relatively small compared with the relay voltage and the distance element operating signal. For example, the distance operating signal for small SIR values is about 10 percent of nominal (see Fig. 16). In a 69 kV system, the operating signal

is $69 \text{ kV} \cdot 0.1 / \sqrt{3} = 4 \text{ kV}$. The assumed 0.5 kV of error from GPR accounts for 12 percent of the distance operating signal. In a 500 kV system with small SIR values, the 0.5 kV error is only 1.7 percent of the distance operating signal.

The GPR cancels in the phase-to-phase voltages, and therefore it only affects the ground distance elements. The effect of GPR can be lumped into the error of the zero-sequence line impedance and accommodated by shortening the reach of the Zone 1 ground distance element compared with the Zone 1 phase distance element (typically 80 percent for phase distance elements vs. typically 75 percent for ground distance elements). This approach works reasonably well if the current sinking into the substation ground and causing the GPR is lower than or equal to the zero-sequence current in the protected line. If the ground current sinking into the substation ground is higher, such as when supplied from the fault through multiple lines, the relay voltage that includes the GPR component is not proportional to the zero-sequence line current and adjusting the ground distance element reach does not solve the problem.

Consider an application in a weak system. For an SIR of 20, the distance element operating signal is below 1 percent of the nominal voltage if the element is set to 80 percent of the line impedance. In a 69 kV application, the example 0.5 kV GPR is higher than the distance element operating signal (0.5 kV GPR vs. 0.4 kV operating signal). In a 500 kV application, the 0.5 kV GPR is lower than the distance element operating signal but is still significant (0.5 kV GPR vs. 2.9 kV operating signal) and may cause problems.

In addition, remember that the GPR is not a voltage drop from the zero-sequence current in the protected line. Multiple paths can supply the zero-sequence current from the fault to the substation. Also, autotransformers can create inverted ground current flows, and ground current loops may be present between multiple primary equipment grounding points in the substation.

The GPR typically makes the line-to-ground voltages read low. The error does not have to be proportional to the zero-sequence line current and it can be magnified by other zero-sequence paths from the fault to the substation (it is a form of zero-sequence infeed related to the substation ground resistance). Consider refraining from applying Zone 1 ground distance elements in weak systems when the GPR is or is suspected to be relatively high.

D. Line Impedance Data

The differences between the apparent impedances of the six distance loops that result from the lack of line transposition are proportional to the line length, and therefore the percentage setting margins they require are similar in strong and weak systems. Short lines are more likely to be untransposed, and you should select the loop with the lowest apparent impedance as the base for setting the Zone 1 distance elements.

The zero-sequence line impedance (Z_0) for lines that are geometrically short is less certain and more variable. The tower footing resistance near the fault and the GPR resistance at the substation may be separated by a relatively short distance. As a result, the “end components” of the apparent Z_0 (the fault itself

and the substation where the relay is located) may become a large factor of the apparent Z_0 compared with the “conductor component” of the apparent Z_0 (impedance of the line between the fault and the substation). Ultimately, the part of the Z_0 that is related to the line length may become negligible if the line is geometrically very short. This violates the basic principle of distance protection, which assumes that the apparent impedance is proportional to the geometrical distance between the fault and the relay. If the part of the apparent Z_0 that is independent of the fault location dominates, the Z_0 is no longer a good measure of the distance to the fault.

E. Mutual Coupling

Mutual coupling may have an outsized impact on distance element applications in weak systems. Moreover, the effect is not limited to ground distance elements, but it can extend to phase distance elements as well. Consider the system in Fig. 20.

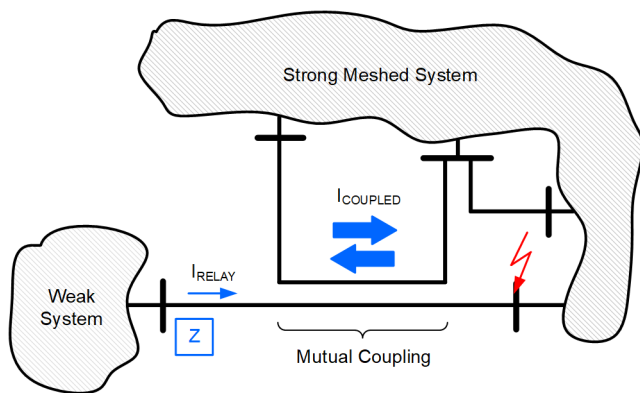

Fig. 20. Effect of mutual coupling in a meshed system with weak and strong terminals.

In a meshed system with strong sources, a line(s) that is mutually coupled to the protected line, can carry an arbitrarily high current relative to the small current that flows in the protected line from the weak terminal. This arbitrarily high current can flow in either direction in a meshed network, and therefore it can boost or reduce the voltage at the relay location for a line-end fault. In weak systems, even a small reduction in the voltage leads to significant distance element overreach. Assuming your short-circuit program models the zero-sequence mutual coupling accurately, you can obtain the apparent impedance values for a range of operating conditions and decide how to set the Zone 1 ground distance element and determine if it makes sense to use it given the reach setting that is required for security.

Zero-sequence mutual coupling is much stronger than the coupling of the negative- and positive-sequence currents. This is because the three conductors of the line are located at relatively similar distances in relation to the equivalent conductors that carry the sequence currents in the coupled line. The coupling in the negative- and positive-sequence circuits is small but not zero, however. If the negative- or positive-sequence current in the coupled line is arbitrarily high, then it induces negative- or positive-sequence voltage even when the coupling coefficient (mutual impedance) is very small. If the line is connected to a weak terminal, that small negative- or

positive-sequence voltage is relatively high compared to the voltage at the relay for the line-end fault. The coupled line current can flow in either direction in the meshed network, and therefore it can boost or reduce the voltage, leading to either underreach or overreach of the phase distance elements.

Your short-circuit program may lack the ability to model the negative- and positive-sequence mutual coupling, and therefore you should apply phase distance elements in weak systems with care, especially when there is a chance that the coupled line carries significant fault current compared with the protected line.

F. Resistive Faults and Accuracy of Polarization

Subsection III.I explained the infeed effect for resistive faults and provided application considerations related to quadrilateral distance elements. It explained the need to keep the resistive reach within a certain limit to prevent small phase angle errors in the polarizing signal from causing the element to overreach for resistive faults.

A distance element is in essence a phase comparator. Phase angle errors in either or both the operating and polarizing signals in (2) change the element characteristic either toward overreaching or underreaching. In weak system applications, it may be the operating signal that exhibits significant phase angle errors, not the polarizing signal. Because the element operates based on the difference between the angles of the two signals, a positive phase angle error in the operating signal has the same impact as a negative phase angle error in the polarizing signal and vice versa. We can analyze phase angle errors in the operating signal as phase angle errors in the polarizing signal.

Consider a memory-polarized mho element first. Typically, the polarizing signal is a memorized (pre-fault) voltage, and as such, it is not affected by transients and other factors related to the fault. However, as emphasized by (26), (27), and (28), small errors in the voltage at the relay location during a fault may change the operating signal, including its phase angle, even if the magnitude of the operating signal is relatively unchanged, i.e., when V_{ERR} in (26) is perpendicular to the true relay voltage V_{TRUE} . This angle error may erode the natural security margin of the mho element for resistive faults. Fig. 21 illustrates this phenomenon by plotting the mho characteristic with and without a small phase error in the polarizing signal. The element restrains if there is no phase error but operates if there is an error.

The same effect, only amplified, applies to the quadrilateral distance elements. Consider that security of a Zone 1 quadrilateral distance element requires the ratio of the resistive reach and the reactive reach to be below a threshold that is related to the expected polarization phase angle error. For example, if you expect a 5-degree error in the polarizing current because of current transformer errors and a 10-degree error in the operating signal because of voltage errors, then the total worst-case phase error in polarization is 15 degrees. If you set the reactive reach to 70 percent of the line impedance, then the highest resistive reach you can afford is only about 1.5 times the line impedance (see Fig. 12).

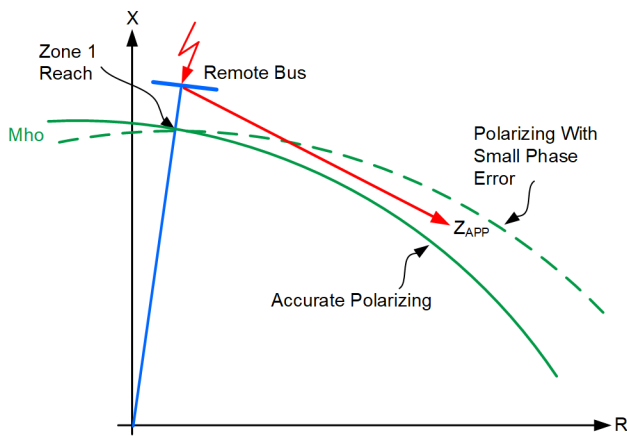

Fig. 21. Mho distance element response in weak system applications during resistive faults and small polarizing phase angle error.

Often, quadrilateral elements are used on short lines because of their ability to extend the resistive reach independently from the reactive reach. However, in weak system applications, this resistive reach extension must be curtailed or else the phase angle errors may lead to the loss of Zone 1 security during resistive faults.

Fig. 22 illustrates another challenge related to quadrilateral distance element applications to short lines – a dependability issue. A close-in resistive fault with a heavy load-out effect can shift the apparent impedance into the fourth quadrant. If the apparent impedance shifts deep into the fourth quadrant relative to the line impedance, a distance element may have issues with directionality and/or faulted-loop selection. Note that sequence directional elements (negative- and zero-sequence directional elements) do not have problems with such conditions and will operate reliably as a part of a pilot protection scheme.

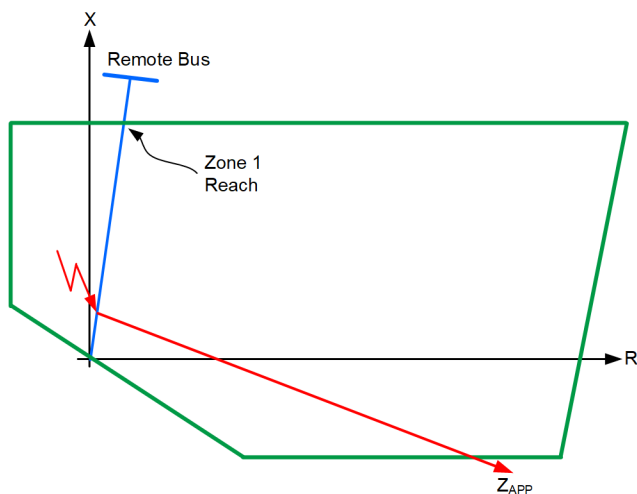

Fig. 22. Dependability challenge for a quadrilateral distance element during resistive faults in applications to short lines.

G. CCVT Transients

At high voltage levels, CCVTs are more economical than magnetic voltage transformers, and therefore they are widely used at voltages above about 150 kV. New technologies make the CCVTs economically viable even at lower voltage levels. The bushing potential device (BPD), often used in sub-transmission networks, is a form of a CCVT.

A high-voltage CCVT uses a capacitive divider to step the voltage down to an intermediate level of 5 to 35 kV and a magnetic transformer to step it further down to the secondary voltage level. A CCVT uses a tuning reactor to compensate – at the nominal system frequency – the phase angle error in the capacitive divider caused by the CCVT burden. Additionally, it uses a ferroresonance suppression circuit to prevent and dampen ferroresonance oscillations that could otherwise occur between the divider capacitance and the nonlinear magnetizing branch of the magnetic voltage transformer. Prior to a fault, the capacitor stack and the tuning reactor store energy that is significant compared with the CCVT burden. When a fault occurs, the stored energy dissipates in the burden and the ferroresonance suppression circuit. It can take a relatively long time (1 to 2 cycles) for the energy to dissipate. Fig. 23 plots a sample CCVT output voltage for a metallic fault at the relay location. The ratio voltage is zero (V_{TRUE} in (26)), and therefore the CCVT output represents the voltage measurement error (V_{ERR} in (26)).

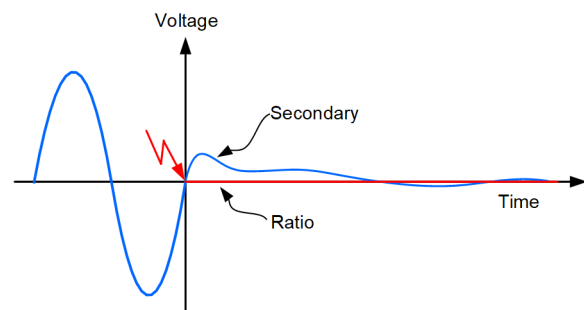

Fig. 23. Sample CCVT output voltage for a metallic fault at the relay location.

Reference [8] analyzes the CCVT transients in detail. The following characteristics of CCVT transients are important for the discussion of distance element applications in weak systems:

- The transient can be as high as 25 to 40 percent of the nominal voltage. This is tenfold higher than the true voltage for a line-end fault in a weak system (see Fig. 15).
- The transient can last a few tens of milliseconds. IEC Standard 61869-5 [9] defines three CCVT transient response classes by specifying the maximum error (in percent of the nominal voltage) as a function of time after the disturbance (see Fig. 24). In our experience, some older CCVTs do not meet the requirements in Fig. 24. The standard allows private agreements between CCVT manufacturers and users regarding the transient error envelope shown in Fig. 24.
- The CCVT transient can exhibit an unchanged polarity for a time longer than half a cycle (often 1 to 2 cycles). This persistent polarity of the error voltage (V_{ERR}) may temporarily invert the polarity of the measured voltage (V_{MEAS}) as compared with the true (ratio) voltage (V_{TRUE}) in (26) if the ratio voltage is small, such as a few percent of the nominal value (see Fig. 15).

- d) The nature of the CCVT transient (decaying or oscillating) depends on the CCVT design, the burden, and the type of the ferroresonance suppression circuit. The transient magnitude depends on the fault point on wave and on the CCVT voltage magnitude level during the fault. The lower the CCVT voltage magnitude during the fault, the larger the change from the nominal pre-fault voltage, and the larger the CCVT transient.
- e) The frequency spectrum of the transient is relatively close to the system nominal frequency. This makes it very difficult for a distance relay to filter out the CCVT transient, especially without introducing a significant delay in protection operation.

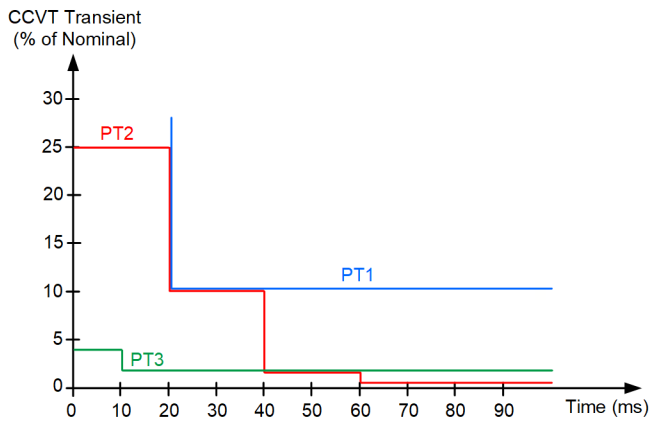

Fig. 24. Transient CCVT requirements per IEC 61869-5.

To fully understand the impact of CCVT transients on the Zone 1 distance element, let us consider the following numerical example. Assume an application with an SIR of 10 and a Zone 1 reach setting of 80 percent of the line impedance. The distance element operating signal for a line-end fault is below 2 percent of the nominal voltage (see Fig. 16). Let us assume that a PT2 CCVT is used and let us analyze the signals 30 ms into the fault. At 30 ms into the fault, the PT2 CCVT may have an error as high as 10 percent of the nominal voltage (see Fig. 24). This error is 5 times higher than the margin of 2 percent in the distance element operating signal. If the error has a persistent polarity, it will override the polarity of the operating signal (27). In this example, a distance relay relies on information as low as 2 percent of the nominal voltage while the noise is as high as 10 percent of the nominal voltage. The 5:1 noise-to-signal ratio is extremely unfavorable. High levels of noise can be effectively filtered out if the frequency spectrum of the noise is sufficiently away from the frequency spectrum of the information signal. However, in the case of CCVT transients, the noise has a frequency close to the system frequency [8], and therefore it cannot be filtered out well by using a generic filter.

In strong systems, the distance element operating signal for line-end faults, even with an 80 percent reach setting, is as high as 10 to 20 percent of the nominal voltage (see Fig. 16). In addition, the CCVT voltage is not reduced much for line-end faults (see Fig. 15), and therefore the CCVT transient is a small fraction of the full 25 to 40 percent transient that occurs for a

metallic fault at the relay location. For example, if the SIR is 0.25, the voltage for a line-end fault is 80 percent of nominal and the voltage change of $100 - 80 = 20$ percent of nominal results in a CCVT transient of $0.2 \cdot (25 \text{ to } 40)$ percent, i.e., 5 to 8 percent of nominal. Therefore, in strong systems, the Zone 1 distance element has a cushion of 10 to 20 percent of the nominal voltage to ride through CCVT transients that are only 5 to 8 percent of the nominal voltage. In applications to weak systems, the situation is reversed: the CCVT voltage for a line-end fault is very small; therefore, the distance element operating signal is low, while the CCVT transients are high.

A simple last-resort solution to CCVT transients in weak system applications is to intentionally delay the Zone 1 element operation. However, depending on the CCVT type and the relay design, the additional time delay required for security can be as high as 30 to 50 ms. Note that such a delay does not solve the problem of the steady-state voltage errors described earlier in this section. Also, the additional delay may be unnecessary when the system configuration changes and the SIR value decreases.

H. Relay Design and Transient Accuracy

Distance relays are designed to address CCVT transients. Carefully study the transient accuracy specifications of the relay before enabling and setting Zone 1 distance elements in weak systems. Applications in weak systems with CCVTs may require enabling a dedicated CCVT security logic based on the SIR and the CCVT type. Make sure you understand the manufacturer's SIR definition before calculating or estimating the SIR. Verify if the Zone 1 transient overreach specification applies to magnetic voltage transformers only or also includes CCVTs. In the latter case, verify that the relay manufacturer transient overreach claim applies to your CCVT type. In the former case, inquire about any additional setting margin you may need to apply or any intentional time delay you may need to set for the Zone 1 distance elements.

The following information can aid you in understanding the relay design and specifications and help you in asking the right questions of the relay manufacturer.

Zone 1 distance elements may use the following approaches to address weak system applications with CCVTs:

- A relay can use an operating torque approach with a carefully selected minimum operating torque threshold. The element operates more slowly as the distance element operating signal decreases. This results in an effective inverse-time delay that is long enough to ride through CCVT transients for line-end faults in weak systems. This approach is natural for electromechanical relays and is explained further at the end of this subsection.
- A microprocessor-based relay can track the movement of the apparent impedance on the impedance plane and delay operation of the Zone 1 distance element until the impedance settles. This approach is based on an observation that a CCVT transient makes the apparent impedance move on the impedance plane. Often, this

logic is active only when explicitly enabled by the user based on the SIR value [3].

- c) A microprocessor-based relay can apply a dedicated filter in the voltage measurement chain to ride through the temporary undershoot in the CCVT output voltage [8]. This approach sacrifices some speed of operation for systems with SIR values in the range of 5 to 10.
- d) A microprocessor-based relay can track several fingerprints of a CCVT transient and use them to slightly delay Zone 1 operation [4]. These fingerprints can include the following:
 - The distance operating signal level – large signals allow faster operation; small signals warrant small intentional delay. This design approach resembles emulating torque-based electromechanical relays.
 - Prolonged periods of unchanged polarity in the distance operating signal – a signal alternating every half cycle allows faster operation; a signal that does not cross zero for a time longer than a half cycle with margin warrants intentional delay.
 - The loop voltage level with respect to the nominal value – high voltage levels (smaller voltage depression) mean lower SIR and lower CCVT transients for line-end faults, allowing faster operation; low loop voltage levels warrant intentional delay.
 - Quality of the distance element operating voltage defined as the difference between the instantaneous signal and its filtered version – small differences inform the relay that the transients are minor, allowing faster operation; large differences warrant intentional delay.
- e) A microprocessor-based relay can incorporate a voltage filter that is designed based on the CCVT transfer function and is thus capable of “reversing” CCVT transients numerically in the relay input voltages [10] [11]. This approach enhances both security and speed but requires tuning the relay in the field to a specific CCVT. The filter settings must be retuned if the CCVT is replaced or the CCVT burden changes.
- f) Another approach is to obtain a cleaner version of the CCVT voltage signal by measuring and integrating the capacitor current by using a low-ratio CT installed at the bottom of the capacitor stack [2] [12]. This approach may be used with merging units.

Let us now discuss electromechanical distance relays in more detail. We will explain why electromechanical relays had a good track record in applications with CCVTs and we will also draw additional observations that apply to microprocessor-based relays. Without going into specifics of any design, we can follow the law of conservation of energy and assume that the product of the operating power and the operating time is approximately constant and equals the energy that is required to operate an electromechanical relay. If A_0 is the energy

required to operate an electromechanical relay and T_{OP} is the operating time, we can write the following approximation:

$$\text{Re}(S_{OP} \cdot S_{POL}^*) \cdot T_{OP} = A_0 \quad (31)$$

We use (24) to represent the operating signal in (31) in terms of the SIR, the per-unit fault location (m), and the per-unit reach setting (m_0). We assume the polarizing signal is constant, and we assume metallic faults for which the operating and polarizing signals are exactly in phase or exactly out of phase. Therefore, from (31), we obtain:

$$T_{OP} = \frac{A_0 \cdot (\text{SIR} + m)}{|S_{POL}| \cdot E \cdot (m_0 - m)} \quad (32)$$

We can replace several constants in (32) with a new constant (C) and represent a delay due to filtering (not shown in (32)) by using a time offset (D). We obtain the following approximation of the operating time:

$$T_{OP} = C \cdot \frac{\text{SIR} + m}{m_0 - m} + D \quad (33)$$

Equation (33) is an approximation. It is based on the law of conservation of energy and it neglects design details. It informs us that the operating time is inversely proportional to the distance between the fault location (m) and the element reach (m_0). The closer the fault is to the reach point, the slower the element operation. The equation also shows that the higher the SIR, the slower the operation. Fig. 25 plots (33) with arbitrary values of the constants C and D (these constants are inconsequential).

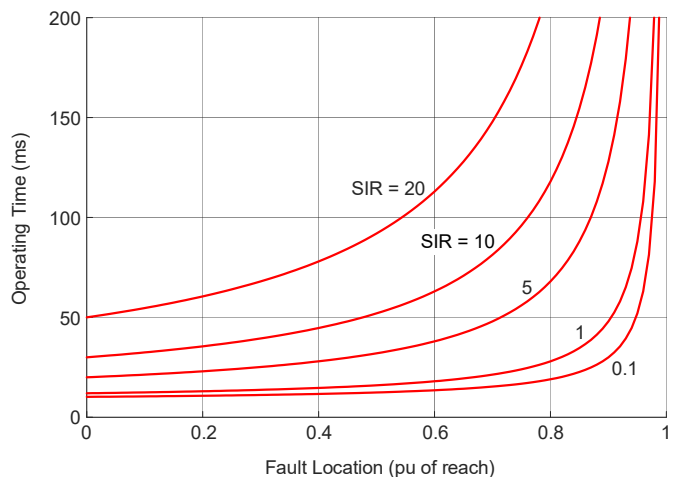

Fig. 25. Operating time per (33) as a function of the SIR and fault location.

The plot in Fig. 25 represents the operating time curves of commercial electromechanical distance relays. These relays had an inherent and significant delay for faults near the end of the zone and for systems with high SIR values. This additional delay allowed electromechanical relays to work relatively well, despite CCVT transients. The time delay in Fig. 25 for line-end faults is so high that it:

- Helps the relay to ride through CCVT transients.
- Allows time coordination with the downstream Zone 1 distance elements (see Fig. 26). This effective time

coordination ensures security even if the element does not maintain an accurate reach. The element picks up for out-of-line forward faults, but the external fault is cleared before the element operates.

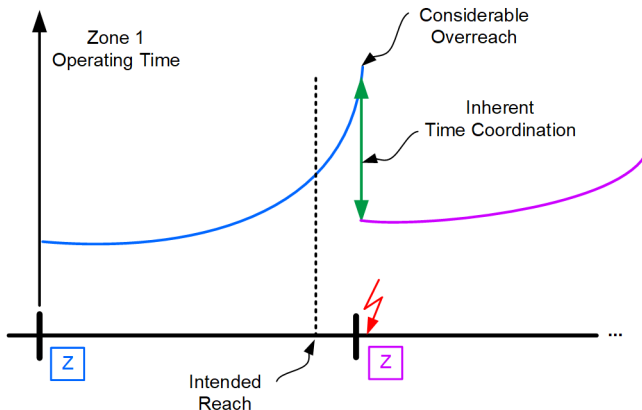

Fig. 26. Illustration of additional Zone 1 distance element security in weak system applications with electromechanical relays.

Microprocessor-based relays do not require any minimum energy to operate. A distance element may assert its output as soon as the operating and polarizing signals come to within the 90-degree comparator limit angle, i.e., when:

$$\text{Re}(S_{OP} \cdot S_{POL}^*) > 0 \quad (34)$$

Expression (34) does not produce any dependency of the operating time on the fault location (m) or SIR. Effectively, (34) only looks at the phase angle between the two signals, and it operates with the same speed regardless of the level of the operating signal. The operating time curves of microprocessor-based relays are relatively flat. Some relays use (34) explicitly [8]. Other relays [3] may use derivations of (34), such as the m-calculation (8a) and (8b). Irrespective of the implementation, a microprocessor-based distance relay ignores signal levels and does not “slow down” when the operating signal is small, unless it is explicitly programmed to do so [4].

In microprocessor-based relays, the operating time is a function of filtering, additional security delay (security counts), and any security measures that may restrain the Zone 1 distance element logic before allowing it to operate. Even though a microprocessor-based relay does not inherently display operating time curves like those shown in Fig. 25, it will still show a similar relationship with respect to the fault location and the SIR, as long as that relay has good transient accuracy (low transient overreach). Fig. 27 shows the Zone 1 distance element operating time curves for a microprocessor-based relay [4]. To remain secure, the Zone 1 distance element must “slow down” for faults located near the reach point, and it must apply more security when the operating signal is low (high SIR). The Zone 1 operating time must increase when the SIR increases and when the fault location approaches the reach point; otherwise, the relay will likely have a poor transient overreach specification.

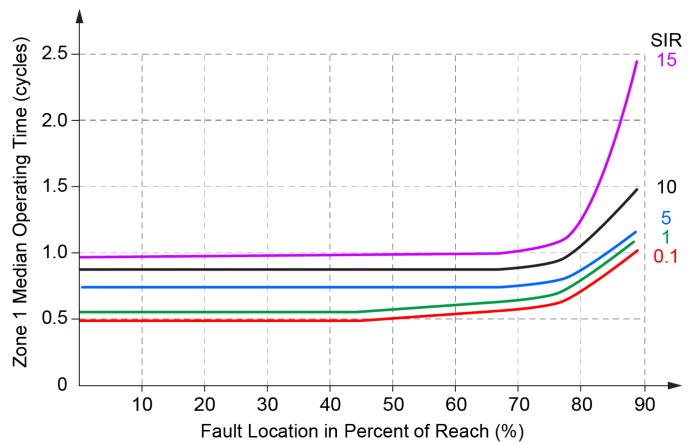

Fig. 27. Microprocessor-based relay [4] Zone 1 distance element operating time curves.

VI. SUMMARY OF ZONE 1 SETTING CONSIDERATIONS FOR APPLICATIONS IN WEAK SYSTEMS

Consider the following approach to Zone 1 distance element applications in weak systems.

1. Remember that all the sources of error that apply to distance protection elements in general (Section III) also apply to weak systems. Keep in mind that in weak systems, many of the general errors have a disproportionately high adverse impact (Section V).
2. Gather the data required to calculate a security margin for the Zone 1 reach setting. Be prepared to contact equipment manufacturers to obtain data outside of the customarily claimed specifications. Be prepared to address uncertainty such as how much voltage may be induced in the secondary voltage cables or how high the ground potential rise can be.
3. Consider that the operating conditions (including the SIR value) for Zone 1 ground and phase distance elements can be different. Typically, the ground elements face more challenges, but there are situations when the SIR can be much lower for the ground elements than for the phase elements, making the application of phase elements more difficult.
4. Consider not using Zone 1 ground distance elements if the degree and complexity of mutual coupling are considerable (many mutually coupled lines, steel pipes and railway tracks, etc.). Remember that the normally negligible negative- and positive-sequence coupling may play an adverse role in weak system applications, and this coupling may impact the phase distance elements.
5. Perform short-circuit studies and find apparent impedance values during normal operating conditions and credible contingencies including lines out of service and grounded. Use the worst-case apparent impedance values as the base for the reach setting, not the positive-sequence line impedance.

6. In new installations or when upgrading relays or replacing CCVTs with a different make and model, use modeling and historical fault records to prove the performance of the Zone 1 distance elements.
7. When upgrading distance relays (different make or model), apply care before directly using settings from in-service relays. Small differences in the relay accuracy and operating principles may make the tried-and-true settings unsuitable.
8. When in doubt, do not apply Zone 1 distance elements but rely on directional comparison and line current differential schemes. Consider using Zone 1 extension logic that allows the Zone 1 element to overreach (even though it is set to underreach) and disables it during autoreclosing.
9. With fast downstream protection, you can apply enough intentional delay to the Zone 1 distance element (circuit breaker time with margin) that you effectively time-coordinate Zone 1 without relying on reach accuracy (see Fig. 26).
10. In systems with highly variable SIR values, consider using overcurrent supervision to allow the Zone 1 distance element to operate when the system is sufficiently strong and to inhibit the Zone 1 distance element operation when the system is weak.
11. Expect more challenges when applying quadrilateral distance elements. Apply large downward tilt angle settings to the reactance characteristic and limit the resistive reach to avoid overreaching for resistive faults.
12. When adding, removing, or replacing relays in the secondary CCVT circuits, verify that the CCVT is properly loaded. Use burden resistors if needed, such as when replacing electromechanical relays with microprocessor-based relays.
13. In new installations, use best practices to bring the secondary voltage and current signals to the relay with the best possible accuracy. Specify magnetic voltage transformers or CCVTs with low and fast dissipating transients (see IEC 61869-5 [9]); use shielded secondary voltage cables and avoid placing them parallel to primary conductors; apply quality grounding; use the voltage transformer tap that provides the highest secondary voltage possible to improve the signal-to-noise ratio.

VII. CONSIDERATION FOR OVERREACHING AND REVERSE-LOOKING ZONES

A. Overreaching Zone 2 Considerations

Used in pilot protection and for step distance protection, Zone 2 distance elements are intended to detect faults along the entire line length, and therefore they are set to overreach the remote line terminal(s).

The general Zone 1 setting considerations in Section III and the considerations for applications in weak systems

(Sections IV and V) also apply to the Zone 2 distance elements. Zone 1 distance element considerations address security (avoiding overreaching and never tripping for remote terminal faults), while Zone 2 distance element considerations must address dependability (avoiding underreaching and always detecting faults along the entire line length). Therefore, when you set Zone 2 distance elements, you should also perform an error budget calculation. Assume that the error makes the element underreach, and compensate for it by extending the reach beyond the line impedance.

Ground distance elements have limited sensitivity to resistive faults. A typical application uses ground directional overcurrent elements in a pilot protection scheme or through time coordination to back up the distance elements. Therefore, ensuring dependability of the overreaching Zone 2 elements is less critical than ensuring security of the underreaching Zone 1 elements.

Overreaching protection elements are always affected by infeed and outfeed conditions. Therefore, it is highly recommended that you set Zone 2 distance elements, intended to provide remote backup for the remote bus faults, by using the apparent impedance values obtained from the short-circuit program, rather than the positive-sequence line impedance.

When used for pilot protection, the Zone 2 reach cannot be arbitrarily high. In directional comparison blocking (DCB) pilot scheme applications, the local Zone 2 distance (forward-looking) elements must coordinate with the Zone 3 distance (reverse-looking) elements in the relay at the opposite terminal of the line, as explained next.

B. Coordination Requirements

Security of the DCB schemes (and to a lesser degree, proper operation of the current reversal logic and the weak-infeed echo logic in permissive pilot schemes) requires the local Zone 3 reverse-looking element to detect every external fault that the remote Zone 2 forward-looking element detects (Fig. 28). The Zone 2 element cannot be more sensitive than the Zone 3 element in the relay at the remote terminal. Reference [13] discusses the coordination requirements in detail and considers a wide range of topics, including the mho and quadrilateral operating characteristics, various polarizing methods, resistive reach settings, application of load-encroachment blinders, and so on.

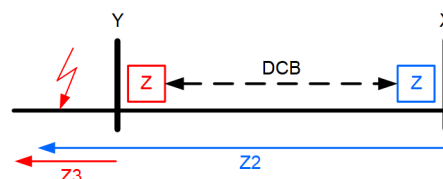

Fig. 28. Zone 2 and Zone 3 coordination requirement.

Referring to Fig. 28, the Zone 2 element at Terminal X and the Zone 3 element at Terminal Y look in the same direction and respond to the current that Terminal X supplies. This may create the impression that the SIR value at Terminal Y is higher than at Terminal X, placing the blocking Zone 3 at a disadvantage compared to the permissive Zone 2. We can use

the system in Fig. 29 to calculate the Zone 2 and Zone 3 operating signals, assuming that both the Zone 2 element at Terminal X and the Zone 3 element at Terminal Y are set to reach up to the same location, denoted as m_0 (per unit of the line length).

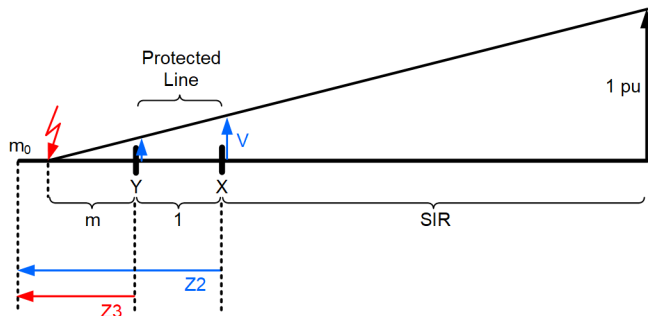

Fig. 29. System equivalent diagram for calculating Zone 2 and Zone 3 element operating signals.

Following the same procedure as in Section IV, we use Fig. 29 to calculate the distance element operating signals (in per unit of the nominal voltage) for the Zone 2 element at Terminal X and the Zone 3 element at Terminal Y and obtain the following equation:

$$S_{OP\ Z2@X\ (PU)} = S_{OP\ Z3@Y\ (PU)} = \frac{m_0 - m}{SIR + 1 + m} \quad (35)$$

The operating signals are identical if the two zones are set to reach up to the same location (m_0). The reverse-looking Zone 3 element is normally set farther than the forward-looking Zone 2 element ($m_{0Y} > m_{0X}$), and therefore it has a higher operating signal. The operating signal of the blocking Zone 3 is higher than that of the permissive Zone 2, and this improves the DCB coordination (Zone 3 provides faster and more dependable operation than Zone 2).

However, when the SIR increases, both zones face the problems described in Sections III and IV. The conditions in Substations X and Y can be different (GPR, voltages induced in the secondary voltage cables, instrument transformer accuracy, CCVT transients, and so on). A DCB application to weak systems that relies on distance elements alone may face both security and dependability issues. A permissive pilot scheme application that relies on distance elements alone may face dependability issues. Using directional overcurrent elements in weak system applications helps with solving these problems.

Another consideration with respect to the system in Fig. 28 is the infeed effect due to parallel elements that supply current from Terminal Y to the fault (compare with Fig. 8). The impact is two-fold. First, the infeed maintains a higher voltage during the external fault than the voltage corresponding to the SIR that is calculated based on the source impedance. As a result, the distance element operating conditions are more favorable. Second, the infeed makes the distance elements underreach as explained in Section III. Because the permissive Zone 2 and the blocking Zone 3 elements measure the same current – at least in a two-terminal application – infeed affects them to the same degree. Reference [13] provides more information on

coordinating permissive and blocking distance elements including the aspects of infeed and fault resistance.

VIII. CONCLUSIONS

The distance element operating signal (the IZ–V term) is a useful tool for analyzing the impact of errors and interfering signals on the security and dependability of distance protection elements. The IZ–V term is an indispensable part of a torque-based electromechanical distance relay, but it is becoming a forgotten art in the microprocessor-based relay technology. This paper re-introduces the IZ–V term and shows how to effectively use it to identify and quantify the impact of errors and interfering signals on distance elements, especially in applications to weak systems.

Maintaining a constant reach that is greatly independent of the fault current level and system configuration is the key advantage of distance protection. In many applications, it allows reach setting calculations based on the positive-sequence line impedance. However, in meshed networks with infeed and outfeed effects, lines with mutual coupling, multiterminal lines, and lines with taps, the apparent impedance is a more reliable measure of the distance between the relay and the remote terminal than the line impedance. This paper recommends using a short-circuit program to obtain apparent impedance values for line-end faults under a range of operating conditions. Use the apparent impedance as the base for distance reach settings, instead of the line impedance.

Quadrilateral distance elements allow for setting a resistive reach independently of the reactive reach. The paper analyzes the impact of phase angle errors in the polarizing signal on the security of Zone 1 quadrilateral distance elements. The paper shows that, for a given maximum expected polarization phase angle error and a given element reactive reach, there is a limit for the resistive reach setting beyond which the element may lose security for resistive faults.

The paper identifies and discusses several conditions that considerably impact the application of distance elements in weak systems, especially the Zone 1 distance elements. Some of these conditions are general conditions that become exacerbated in applications to weak systems (mutual coupling, for example). Others are phenomena that do not play any role in strong systems and are therefore neglected in standard setting calculation procedures (ground potential rise or voltages induced in secondary cables, for example).

The paper briefly discusses transients, especially CCVT transients, and how the distance element design may address CCVT transients in weak system applications. The paper explains why the combination of CCVT transients and high SIR values is receiving significant attention in the era of microprocessor-based relays and why it was a less significant topic in the days of electromechanical distance relays.

Importantly, the paper emphasizes steady-state errors in weak system applications. These errors and interfering signals receive little or no attention in the literature. Steady-state errors can only be accommodated by settings and not by distance

element design. The paper shows that some of the data required to calculate the distance element reach settings in weak system applications may be difficult to obtain, may require contacting the equipment manufacturer, or may require approximation.

The paper provides a list of recommendations for distance element applications in weak systems. The list includes tangible engineering steps and calculations as well as items related to ambiguous data and risk mitigation.

Setting distance elements is a typical engineering task that is based on identifying errors and interfering signals, collecting relevant data, calculating the worst-case error, and providing enough margin in the reach setting to account for the combination of errors. In principle, setting distance elements in weak systems can follow the same approach. However, in weak systems, it becomes more difficult or even impossible to obtain accurate data on some errors. As a result, much larger reach setting margins may be needed for security (Zone 1) or dependability (Zone 2). When the margins become too large, the element dependability is diminished. It may be a better solution to refrain from applying distance elements and instead use pilot protection schemes with directional overcurrent elements or line current differential schemes.

IX. REFERENCES

- [1] H. J. Altuve Ferrer and E. O. Schweitzer, III (eds.), *Modern Solutions for Protection, Control, and Monitoring of Electric Power Systems*, Schweitzer Engineering Laboratories, Inc., Pullman, WA, 2010.
- [2] E. O. Schweitzer, III and B. Kasztenny, "Distance Protection: Why Have We Started With a Circle, Does It Matter, and What Else Is Out There?" proceeding of the 71st Annual Conference for Protective Relay Engineers, College Station, TX, March 2018.
- [3] *SEL-421 Protection, Automation, and Control System Instruction Manual*. Available: selinc.com.
- [4] *SEL-T401L Ultra-High-Speed Line Relay Instruction Manual*. Available: selinc.com.
- [5] IEC 60255-121:2014, *Measuring relays and protection equipment – Part 121: Functional requirements for distance protection*.
- [6] F. Calero, "Mutual Impedance in Parallel Lines – Protective Relaying and Fault Location Considerations," proceedings of the 34th Annual Western Protective Relay Conference, Spokane, WA, October 2007.
- [7] M. Thompson and A. Somani, "A Tutorial on Calculating Source Impedance Ratios for Determining Line Length," proceeding of the 68th Annual Conference for Protective Relay Engineers, College Station, TX, March 2015.
- [8] B. Kasztenny, D. Sharples, V. Asaro, and M. Pozzuoli, "Distance Relays and Capacitive Voltage Transformers – Balancing Speed and Transient Overreach," proceedings of the 54th Annual Georgia Tech Protective Relaying Conference, Atlanta, GA, May 2000.
- [9] IEC 61869-5:2011, *Instrument transformers – Part 5: Additional requirements for capacitor voltage transformers*. (replaces IEC 60044-5:2004).
- [10] J. Izykowski, B. Kasztenny, E. Rosolowski, M. M. Saha, and B. Hillstrom, "Dynamic Compensation of Capacitive Voltage Transformers," *IEEE Transactions on Power Delivery*, Vol. 13, Issue 1, January 1998, pp. 116–122.
- [11] U.S. patent 7,567,881, "Self-adjusting voltage filtering technique compensating for dynamic errors of capacitive voltage transformers."
- [12] U.S. patent 10,802,054, "High-fidelity voltage measurement using a capacitance-coupled voltage transformer."

- [13] B. Kasztenny, M. V. Mynam, N. Fischer, and A. Guzmán, "Permissive or Blocking Pilot Protection Schemes? How to Have It Both Ways," proceedings of the 47th Annual Western Protective Relay Conference, Spokane, WA, October 2020.

X. BIOGRAPHIES

Bogdan Kasztenny has over 30 years of experience in power system protection and control. In his decade-long academic career (1989–1999), Dr. Kasztenny taught power system and digital signal processing courses at several universities and conducted applied research for several relay manufacturers. In 1999, Bogdan left academia for relay manufacturers where he has since designed, applied, and supported protection, control, and fault-locating products with their global installed base counted in thousands of installations. Bogdan is an IEEE Fellow, a Senior Fulbright Fellow, a Distinguished CIGRE Member, and a registered professional engineer in the province of Ontario. Bogdan has served as a Canadian representative of the CIGRE Study Committee B5 (2013–2020) and on the Western Protective Relay Conference Program Committee (2011–2020). In 2019, Bogdan received the IEEE Canada P. D. Ziogas Electric Power Award. Bogdan earned both the Ph.D. (1992) and D.Sc. (Dr. habil., 2019) degrees, has authored over 220 technical papers, and holds over 50 U.S. patents.