

# Improved Transformer Condition Monitoring using IEEE C57.109 Through Fault Detection Algorithm

Matthew Leyba, Venkatesh Rokkam, Emmoji Vundekari (GE Renewable Energy)

## I. Abstract

Transformers are one of the critical assets in the substation. In general, transformers are protected with differential or unit protection and the protection zone is defined by the location of CTs. Through faults or external faults are categorized as faults outside the differential protection zones and excessive currents due to an external fault is not detected by the differential protection. The life expectancy for liquid-immersed power transformers is largely influenced by the number of “through-fault” operations.

IEEE standard C57.109 – 2018 provides transformer short-circuit withstand capability considering both thermal and mechanical damage. Magnitude and duration of fault currents are of utmost importance in establishing a coordinated protection practice for transformers, as both the mechanical and thermal effects of fault currents should be considered. For fault-current magnitudes near the design capability of the transformer, mechanical effects are more significant than thermal effects. At low fault-current magnitudes approaching the overload range, mechanical effects assume less importance, unless the frequency of fault occurrence is high. The point of transition between mechanical concern and thermal concern cannot be precisely defined, but mechanical effects tend to have a more prominent role in larger kilovolt ampere ratings, because the mechanical stresses are higher.

This paper provides a comparative analysis of methods for transformer through fault monitoring per IEEE Std C57.109™-2018 withstand capability curves and presents improved algorithm for through fault monitoring. Multiple fault scenarios of Category II and Category III transformers are simulated using EMTP/PSCAD software, respective fault current and fault clearing times are calculated. The information of these fault scenarios is imported into MATLAB/SIMULINK to calculate transformer accumulated stress (cumulative thermal/mechanical damage) for different methods. A comparative analyses of transformer maintenance scheduling with different faults is presented with graphical results.

## II. Introduction

Transformers are considered as critical assets in power system and any failure may lead to major load outage, which can result in energy interruption and financial loss. Though multiple failure modes are considered at the time of transformer design, regular maintenance is vital to prevent unexpected failure of transformer. Health condition of the critical assets like transformer are monitored by condition monitoring devices and protective relays, and the assets are monitored at regular intervals [1]. The advanced predictive maintenance algorithms employed in health monitoring devices can alarm the next probable maintenance time precisely [2].

Even though the transformer is a static device, the abnormal system conditions may raise the internal stress. Majority of the internal faults are sensed by the transformer differential protection. The excessive currents through the transformer windings are caused due to overloads or external short circuits accumulates the mechanical and thermal stress inside the transformer windings and connecting terminals [3]. Thermal stress may result in winding overheating, which may damage the transformer insulation and cause excessive wear on transformer. These factors lead to a reduction in the transformer's life expectancy.

In the power transformer protection, the position of the CT secondaries defines the transformer differential protection zone and the faults that are outside the transformer differential protection zone are considered as through-faults. The through fault monitoring function in the protection relays calculates the accumulated mechanical and thermal stress on the transformer windings by tracking the number of through faults through the windings, the number of faults per phase, and the accumulated percentage of the transformer's through-fault capability, and the fault duration and magnitude. Conventionally the transformer remaining withstand capability is calculated using the cumulative  $I^2t$  and is a measure to raise an alarm for asset maintenance.

However, many real-world cases are reported, where the transformer damaged before the conventional  $I^2t$  through fault monitoring function raised an alarm [4]. IEEE standard C57.109 – 2018 [5] and IEEE standard C57.12.59 – 2015 [6] considers both thermal and mechanical damage for calculating transformer short-circuit withstand capability. In order to consider the mechanical and thermal effects of fault currents, the Magnitude and duration of fault currents are the criteria in establishing a coordinated protection practice for transformers. At lower fault currents, mechanical effects are minimal, unless the fault current frequency is high. For fault-current magnitudes near the design capability of the transformer, mechanical effects are more significant than thermal effects. The transition point between thermal and mechanical concern may not be precisely specified, but mechanical effects incline to have more significant role in higher kVA ratings, as the mechanical stresses are higher.

Internal transformer faults are extremely rare and are always treated seriously case-by-case. External downstream faults are not that rare and can cause cumulative damage to the transformer, if not monitored and accounted for. Figure 1 below demonstrates the through fault for the 2-winding and 3-winding transformers. For the 2-winding through fault will cause relatively the same thermal and mechanical damage due to fault current maintains the same "times rated current" ration on both HV and LV windings. It means one through fault monitoring element is enough for such transformer. For the 3-winding transformer, one through fault monitoring element is not enough because there is current contribution from other windings and each winding must be monitored separately.

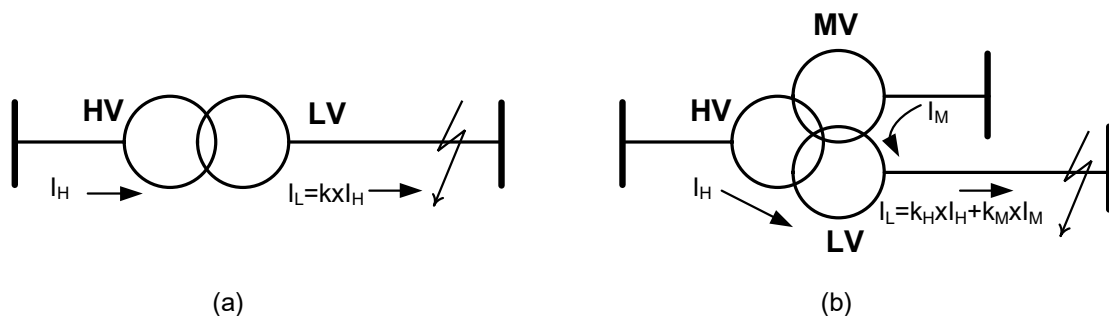

**Figure 1. Fault through 2-winding transformer (a) and 3-winding transformer (b)**

This paper presents a comparative study of conventional I2t withstand capability curves and improved transformer condition monitoring algorithm using IEEE Std C57.109™-2018 withstand capability curves for through fault monitoring. A typical power system network comprising of Category II and Category III transformers are simulated using EMTP/PSCAD software. Multiple fault scenarios at different locations of the power system are simulated and respective fault current and fault clearing times are calculated. The results are imported to MATLAB/SIMULINK to calculate transformer accumulated thermal/mechanical stress for both conventional I2t and IEEE Std C57.109™-2018 withstand capability curves. A comparative study with graphical results is presented for transformer maintenance scheduling with different faults.

**III. Transformer Withstand Capability Curves**

IEEE Std C57.109- 2018 and IEEE Std C57.12.59- 2015, provide maximum through fault current duration limit curves for liquid-immersed and dry type transformers, respectively.

Category I has a single curve reflecting both thermal and mechanical damages. For currents greater than 5 times the rated current, thermal/mechanical damage may happen when I2t is greater than 1250 (square of pu symmetrical fault current multiplied by duration of fault in seconds). For Category I of liquid-immersed transformers, the standard recommended curve covers up to 40 pu fault currents (time limit equal to 0.78 seconds). For all other transformer categories and types, the maximum symmetrical short circuit current covered by the curves is 25 pu.

Category II and III transformers subjected to infrequently occurring faults are also represented by the same threshold of 1250. Beyond this threshold, thermal damage may occur to the transformer.

Category II and III transformers subjected to frequently occurring faults and transformers of Category IV, have thermal/mechanical damage curves. These curves define the damage threshold based on maximum fault current for the transformer as defined by Maximum Fault Current setting. For Category II transformers, cumulative mechanical damage may occur if the symmetrical through fault current is above 70% of maximum fault current. For Category III and IV, symmetrical through fault currents above 50% of the maximum fault current may cause cumulative mechanical damage. Damage threshold for fault current levels beyond above points is equal to: 2 times square of the Maximum Fault Current. This reflects the worst-case mechanical duty of 2 seconds at maximum fault current. Damage threshold for fault current levels below above-mentioned fault current points will be 1250 (primarily thermal damage).

Category	Single Phase (kVA)	Three-phase (kVA)
I	1 - 500	15 -500
II	501 - 1667	501 - 5000
III	1668 - 10000	5001 - 30000
IV	Above 10000	Above 30000

**Table 1. Transformer categories**

This element determines the thermal/mechanical damage withstand capability at each execution and integrates the damages of all detected through faults in per unit of the associated withstand capability. When the total damage or the total number of faults exceed the defined settings it asserts the corresponding phase Operate flag.

Different damage curves for different categories are provided by the standard. For categories II and III two curves are provided. This is to reflect on both thermal and mechanical damage considerations and also on the frequently or infrequently occurring faults.

Time (s)	Times rated current
2	25
10	11
30	6.3
60	4.5
300	3
1800	2

**Table 2. Transformer short-time thermal load capability**

Categories I, II and somewhat III are mostly for the distribution transformers and categories III and IV are for the transmission transformers. Digital protective relays are mostly used to protect transmission class transformers, while distribution class transformers may be protected by the fuse, requiring a standalone device to monitor transformer damage due to through faults. In Figure 2 below damage curves for the category IV transformer are shown, where solid line represents the thermal damage, while dashed line represents the mechanical damage.

Power transformers are naturally reducing external fault through current due to their impedance. IEEE standards are recognizing this by providing curves for different transformer impedances. For example, transformer impedance of 10% means that external downstream fault current cannot be higher than 10 times rated current. Figure 2 below demonstrates two values of the transformer impedances, 10% and 6%. IEEE standards imply that for 10% transformer impedance the mechanical damage can occur after 3 seconds of the cumulative fault time, while thermal damage can occur after 10.8 seconds of the cumulative fault time, as shown with the brown vertical line.

IEEE standards also differentiate between faults and possible overloads. The 2-slope characteristics in the solid line has a break at 5 times rated current point, shown in thick grey line in the Figure 2. Below this value current is considered as possible overload, causing much less damaging effect. Currents below 5 times rated are not included into mechanical and thermal damage calculations.

For fault-current magnitudes closer to the maximum short-circuit current rating of the transformer, mechanical effects are more significant than thermal effects. The maximum symmetrical short-circuit current should not exceed 25 times normal base current in accordance with IEEE Std C57.12.01. The clear border line between mechanical damage and thermal damage cannot be precisely defined, but mechanical effect have more prominent effect in larger MVA rating transformers.

Through-fault protection curves are based on the equation:

$$I^2 \times t = k \quad \text{Eq. 1}$$

Where  $k$  is the constant determined at the maximum current with  $t = 2$  seconds

Consequently,

$$k = I_b^2 \times t = 25^2 \times 2 = 1250 \quad \text{Eq. 2}$$

Where  $I_b = 25$  is base current per IEEE standards

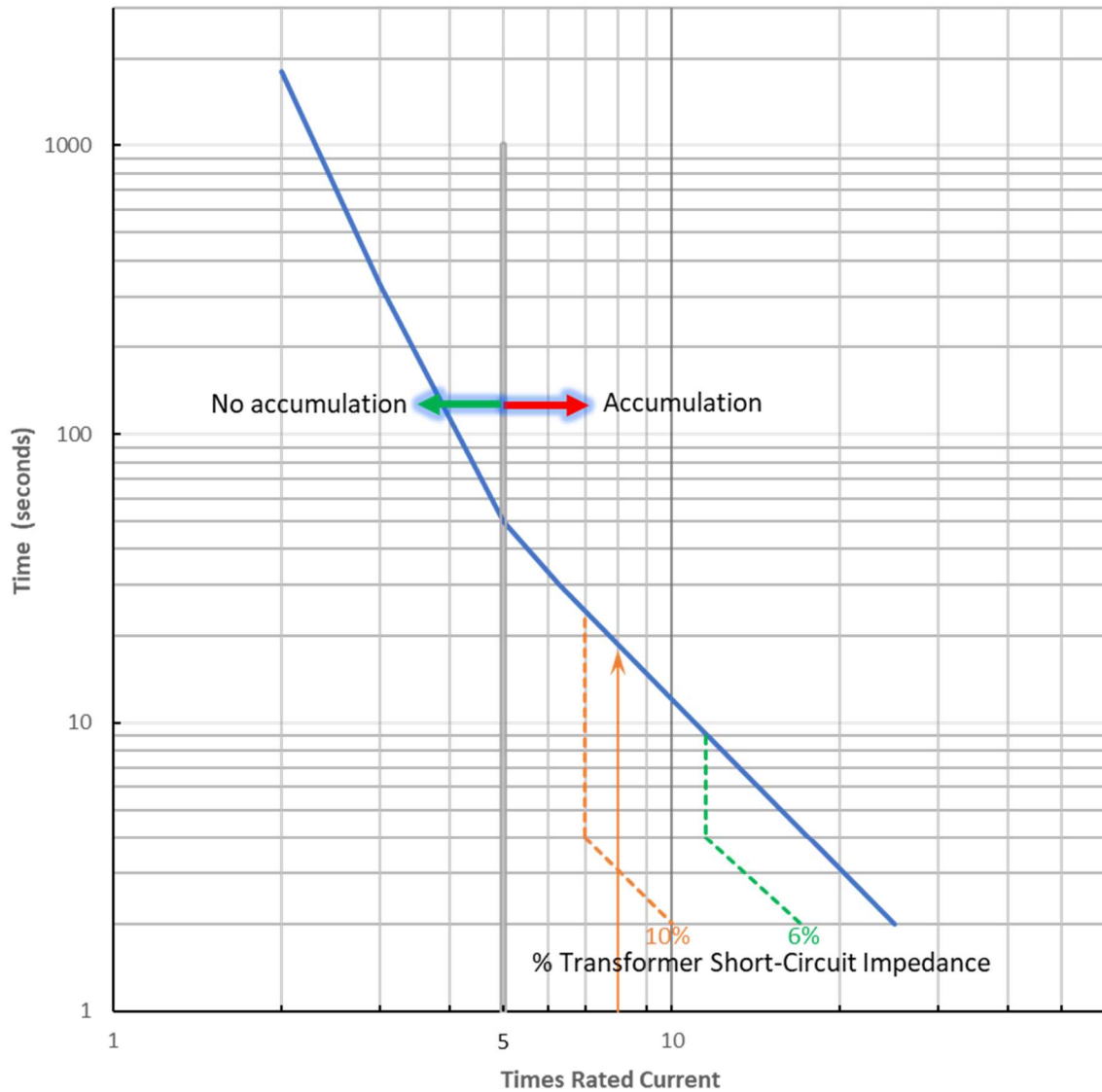

**Figure 2. Through fault curves for category IV (above 10 MVA) transformers**

$$\text{Equation } k = I_b^2 \times t = 25^2 \times 2 = 1250$$

Eq. 2 becomes the basis of the through fault protection curves for different categories with some specific details.

For different categories, different rules and curves are applied for damage value calculations per IEEE standards. For the category IV transformers, damage accumulation should occur for currents 50% to 100% maximum possible. For example, for fault at 50% or 70% of the maximum possible, maximum time tolerable time is longer and can be estimated as:

$$t_{70\%} = \frac{1250}{(0.7 \times 25)^2} = 4.08s, t_{50\%} = \frac{1250}{(0.5 \times 25)^2} = 8s \quad \text{Eq. 3}$$

Now, for different transformer short circuit impedances, the maximum tolerable time differs as well. For transformer with a 10% short circuit impedance, the maximum fault current for 100% at 2s can be determined as follows:

$$I_{100\%}^{Z10} = \frac{100\%}{10\%} = 10pu; I_{100\%}^{Z6} = \frac{100\%}{6\%} = 16.67pu \quad \text{Eq. 4}$$

Accordingly, for 70% at 4.08s for example, it will be:

$$I_{70\%}^{Z10} = \frac{70\%}{10\%} = 7pu; I_{70\%}^{Z6} = \frac{70\%}{6\%} = 11.67pu \quad \text{Eq. 5}$$

The higher the short circuit impedance of the transformer, the lower is maximum through fault current  $I_M$ , as seen from the Table 3 below. However, damage detection time from 50 to 100% remains the same for all impedances and is from 2s to 8s, as shown for 50, 70% and 100% of the maximum through fault current.

Transformer impedance (%)	Symmetrical short-circuit current (pu of winding rated current)		
	100% $\times I_M$ , t=2s	70% $\times I_M$ , t=4.08s	50% $\times I_M$ , t=8s
4 (base)	25	17.5	12.5
6	16.67	11.67	8.33
8	12.5	8.75	6.25
10	10	7	5

**Table 3. Maximum through fault current dependance on the impedance**

For the category IV large MVA transformer shown above in Figure 2 as an example, single damage curve is applicable to frequent or infrequent (typically not more than 5 times for categories III and IV and 10 times for categories I and II in the life of a transformer) faults. IEEE standards govern different damage accumulation for faults 50% to 100% of the maximum possible and below 50% of the maximum possible through fault current  $I_M$ .

For faults 50% to 100% of the maximum possible and time from  $2s \leq t \leq 8s$  accordingly, accumulation is:

$$I^2 \times t = 2 \times \left(\frac{100}{Z}\right)^2 \quad \text{Eq. 6}$$

For faults below 50% of the maximum possible and time from  $0.5 \times Z^2 \leq t \leq 102s$  accordingly, accumulation is:

$$I^2 \times t = 1250$$

Eq. 7

For  
IEEE

#### IV. Improved Transformer Through Fault Monitoring Function

Digital  
Different

Cumulative damage for n faults until reaching damage limit of 1250 is calculated using single equation  $THRU\_FLT\_Accum = \sum_0^n \frac{I_n^2 \times \Delta t_n}{Lim} \leq Set (pu)$

Eq. 8 below.

$$THRU\_FLT\_Accum = \sum_0^n \frac{I_n^2 \times \Delta t_n}{Lim} \leq Set (pu) \quad \text{Eq. 8}$$

Where  $I_n$  is n fault current magnitude,  $\Delta t_n$  is n fault duration and  $Lim$  is defined as:

$$\text{If } I_n > 0.5 \times I_M \quad \text{Eq. 9}$$

$$Lim = 2 \times I_M^2$$

Otherwise

$$Lim = 1250$$

Equation  $\text{If } I_n > 0.5 \times I_M$  Eq. 9 signifies that for higher magnitude faults 50% to 100% of the maximum, accumulation is happening much faster and is based on the 2s requirement at 100% maximum fault. For lower magnitude faults, accumulation is slower and is based on the 1250 limit defined by the IEEE standards. Also for convenience, accumulation is defined in pu, where 1pu corresponds to either 2s at 100% fault or to 1250 value.

To demonstrate how  $THRU\_FLT\_Accum = \sum_0^n \frac{I_n^2 \times \Delta t_n}{Lim} \leq Set (pu)$

Eq. 8 ensures accumulation for different fault level, we assume category IV transformer with  $Z\%=8$ . Per  $I_{100\%}^{Z10} = \frac{100\%}{10\%} = 10pu$ ;  $I_{100}^{Z6} = \frac{100\%}{6\%} = 16.67pu$  Eq. 4,  $I_M = 12.5 pu$ . For the same assumed duration of the through fault of 0.1 s, the accumulation will be different at different fault levels.

$I_n$ (pu)	$I_M$ (pu)	$\Delta t_n$ (s)	$THRU\_FLT\_Accum$ (pu)
12.5	12.5	0.1	0.05
10	12.5	0.1	0.032
8	12.5	0.1	0.0205
6	12.5	0.1	0.0029

**Table 4. Example of category IV accumulation for single fault 0.1s duration**

It means that at maximum fault current of 12.5pu, transformer can tolerate  $1\text{pu}/0.05\text{pu}=20$  times same fault magnitude, or at 10pu can tolerate  $1\text{pu}/0.032\text{pu}=31$  times same fault magnitude, or at 8pu can tolerate  $1\text{pu}/0.0205\text{pu}=48$  times same fault magnitude and 6pu can tolerate  $1\text{pu}/0.0029\text{pu}=347$  times same fault magnitude accordingly IEEE standards.

Table 5 below gives a list of settings need to be entered by the user to achieve required functionality. Besides obvious settings, provision is made accommodate single or dual CT input, compensation for the delta winding measurement, pre-setting accumulation for the case when relay is connected o the transformer which was in service before.

Setting name	Setting purpose
CT SOURCE	Single CT or dual CT (2 breakers) input
GROUP COMPENSATION	In case of CTs are outside delta winding to divide current by $\sqrt{3}$ to obtain winding current
RATED MVA: 100.000	Rated MVA of the winding monitored to derive base current
RATED PHS-PHS KV	Rated voltage of the winding monitored
WINDING CATEGORY	Transformer category, I, II, III or IV to apply proper curve per standard
MAX FAULT CURRENT	Maximum through fault current derived from transformer Z% impedance
FREQUENT FLT LEVEL	Threshold for categories II and III for different curves for frequent or infrequent faults.
TOTAL ACCUMULATION MAX	Threshold to define output of the element, if accumulation exceeds maximum tolerable
FAULT COUNTER MAX	Threshold to set a through faults count to issue an alarm if exceeds
RESET/PRESET ACCUMULATION	If relay is commissioned to a transformer that was in service, set the known value from old relay

**Table 5. Improved monitoring algorithm settings**

Another significant advantage that digital relays can give is ability to monitor and visualize accumulation and ability to analyze each fault individually and impact on the transformer. Following values are monitored and available for valuation in the improved through fault monitoring function:

- Count of through faults per phase per winding
- Total accumulation per phase per winding
- Through fault time per each event
- Through fault accumulation per each event
- Through fault duration per each event
- Through fault maximum current per each event per each phase

PARAMETER	MONITOR1
Crit A	2
Crit B	5
Crit C	5
Total Acc A	0.018 pu
Total Acc B	0.073 pu
Total Acc C	0.049 pu
Ev1 Time	Monday, September 21, 2020 10:03:52 AM
Ev1 Duration	12.5 cyc
Ev1 Max Cur A	10.37 pu
Ev1 Max Cur B	15.58 pu
Ev1 Max Cur C	4.15 pu
Ev1 Acc A	0.0073 pu
Ev1 Acc B	0.0163 pu
Ev1 Acc C	0.0000 pu

**Figure 3. Example of through fault monitoring accumulation values**

Each start or operation of the through fault monitoring function can be recorded for further analysis. Oscillography record includes winding currents and voltages, start and end of the accumulation and value of the accumulation for each phase in each winding. Figure 4 below demonstrates an example of the Comtrade record of the through fault accumulation for the 3-phase through fault, followed by the AG fault causing accumulation in phase A above the threshold and consequent operation of the function.

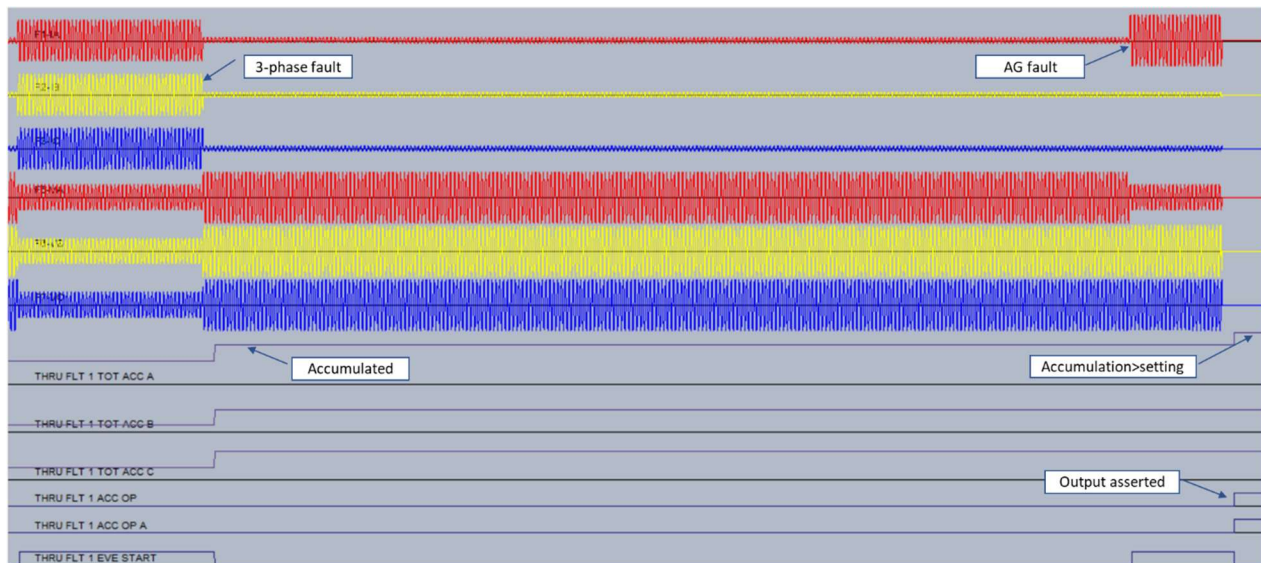
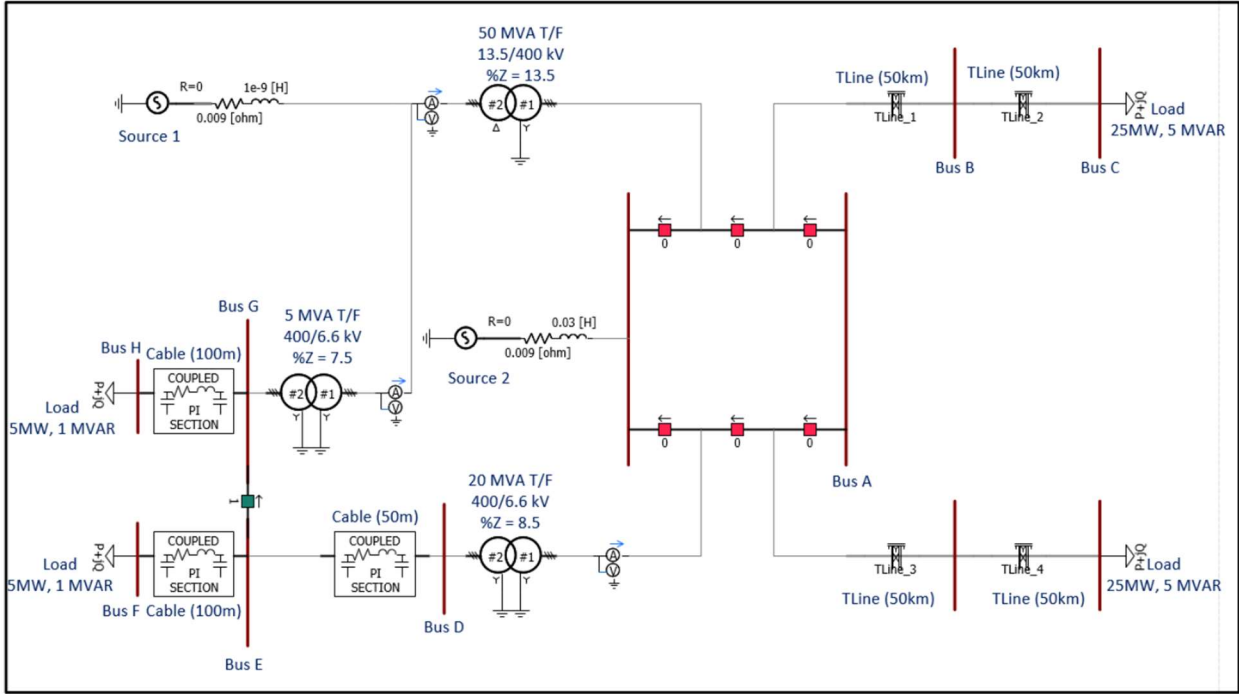

**Figure 4. Example of through fault monitoring recording**

Recording functions assist user to visualize and analyze through fault events accumulation and plan predictive maintenance in advance.

#### V. Comparison of the conventional $I^2t$ capability curves and IEEE Std C57.109™-2018 capability curves

To compare performance of the conventional  $I^2t$  withstand capability curves with IEEE Std C57.109™-2018 withstand capability curves, a study using EMTP/PSCAD software was performed. It included several different categories of the power transformer with several fault scenarios, shown in the Figure 5 below.



**Figure 5. Power network with several categories' transformers**

Category IV transformer (50MVA, 13.5/400kV & %Z=13.5) was one of considered for analyzing transformer through faults damage accumulation. As illustrated above, a typical power system network is considered for analyzing all categories scenarios, where transformer in the top of the figure was a category IV, described below. Different fault type, fault level fault resistance and fault duration was considered.

Fault label	$R_F(\Omega)$	Location	Fault type	$I_F$ (pu)	$t_F$
F1	0	Bus A	LLG	7.07	0.45
F2	10	Bus A	LG	5.6	0.55
F3	0	Bus B	LG	5.3	0.58
F4	10	Bus B	LG	5.12	0.59
F5	10	Bus C	LG	3.6	0.65
F6	15	Bus C	LG	3.4	0.68

**Table 6. Faults for category IV transformer performance evaluation**

In this case, the through fault cumulative thermal and mechanical damage threshold is considered as 1pu. As shown in Fig. 5, with the IEEE Std C57.109 withstand capability curves the accumulated stress of 1pu can be seen at fault F2. However, with conventional  $I^2t$ , the accumulated stress did not reach the threshold. In case of conventional  $I^2t$ , the transformer through fault protection will not raise

any alarm for maintenance. However, with IEEE Std C57.109 withstand capability curves an alarm will be raised for maintenance alert.

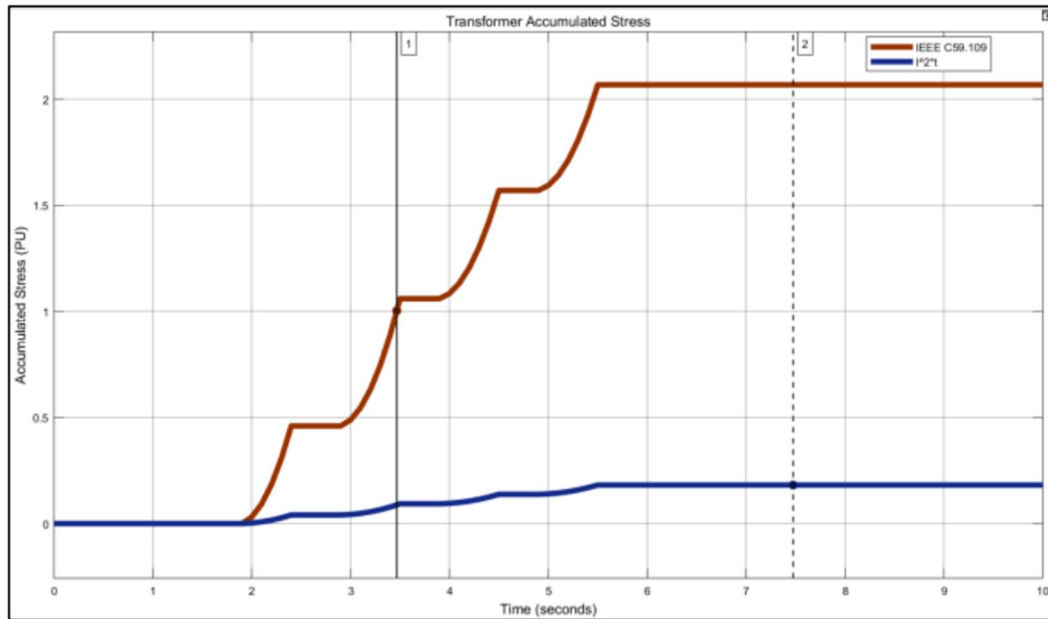

**Figure 6. Accumulation comparison for  $I^2t$  and IEEE Std C57.109 methods**

For other transformers categories it was observed the same pattern that IEEE Std C57.109 method is performing much better.

## VI. Conclusions

IEEE Std C57.109- 2018 and IEEE Std C57.12.59- 2015 for liquid-immersed and dry-type transformers respectively, provide maximum through fault current duration limit curves for liquid-immersed and dry type transformers, respectively. These standards are based on the accumulated knowledge and observation of many transformers for many years. It is important to monitor through faults to schedule maintenance before damage occurs.

For high-magnitude faults near design capability, the mechanical damage is more significant compared with a thermal damage. During high-magnitude faults mechanical stresses are much higher and shortening transformer life.

Modern protective relays provide essential functionality for the transformer through fault monitoring and allow to continuously monitor through faults. These relays truly follow IEEE standards and can be set for any transformer category. They provide extensive monitoring and recording capabilities and can issue alarm or trip when is dangerous to continue operating transformer without maintenance.

As it was demonstrated in the paper, the study comparing conventional  $I^2t$  method with IEEE methods, proved that IEEE methods ensure much better performance.

## VII. References

1. IEEE Std C57.109™-2018, "IEEE Guide for Liquid-Immersed Transformers Through-Fault-Current Duration"

2. IEEE Std C57.12.59™-2015, "IEEE Guide for Dry-Type Transformer Through-Fault Current Duration".
3. Venkatesh Rokkam, Chakravarthy M, Hazarath Voleti, Emmoji Vundekari, "Transformer Condition Monitoring Considering improvements in Through Fault Protection", DPSP-2022.
4. GE Publication 1601-0090-AM1, T60 Transformer Protection System, 2022.