

# Applying and Commissioning a Sustainable Multi Application IEC61850 Process Bus Protection Scheme

Mike Ramlachan, GE Renewable Energy, USA  
Glenn Wilson, Southern Company, USA  
Jim Campbell, Southern Company, USA

## 1. Introduction

Multi application protective relays, such as feeder relays that can protect and control multiple feeders independently, though not widely adopted, have been commercially available for over 15 years. Process bus enables the adoption of these multi application relays by simplifying the field wiring involved to only fiber optic connections and establishing a protection scheme with clear benefits to utilities. It will be shown that this scheme is secure, testable, dependable, adaptable, and easily expandable such that this concept can be extended to larger substations. However, process bus seemingly complicates the application and field testing of these devices.

This paper will focus on re-designing a real-world conventional distribution substation, each feeder protected by its own relay, and transitioning towards a multi application relay encompassing all feeders utilizing IEC 61850 process bus. Strategies for applying and testing this process bus based distribution substation protection using the test modes and simulation capabilities of the IEC 61850 standard will be discussed. Redundancy will also be discussed since typically in a distribution substation redundant protection may not be applied due to cost considerations. Different redundant and non-redundant application strategies will be discussed including relay, merging unit and network redundancy. Maintenance testing may require testing individual protection zones (feeder) of a multi application relay while leaving the other zones (feeders) in service. The IEC 61850 standard provides a framework for such testing; however, the test methodology and procedure must be carefully applied to ensure risk-free testing. Both test modes and simulation of data must be used in conjunction, in the right sequence, for successful testing. Such a methodology will be described. Lessons learned will be discussed for this real world multi application process bus design, application and installation.

## 2. Conventional Distribution Substation

A typical distribution substation is supplied by a least one sub-transmission feeder, it can also be supplied by two or more supplies to increase reliability. Each supply feeder is terminated into a step-down power transformer to convert the sub-transmission level voltage to a distribution level, typically from 4kV to 34.5kV. These transformers supply a distribution bus to which several outgoing distribution feeders are connected via circuit breakers to supply points of service. Figure 1 shows a one line of this arrangement.

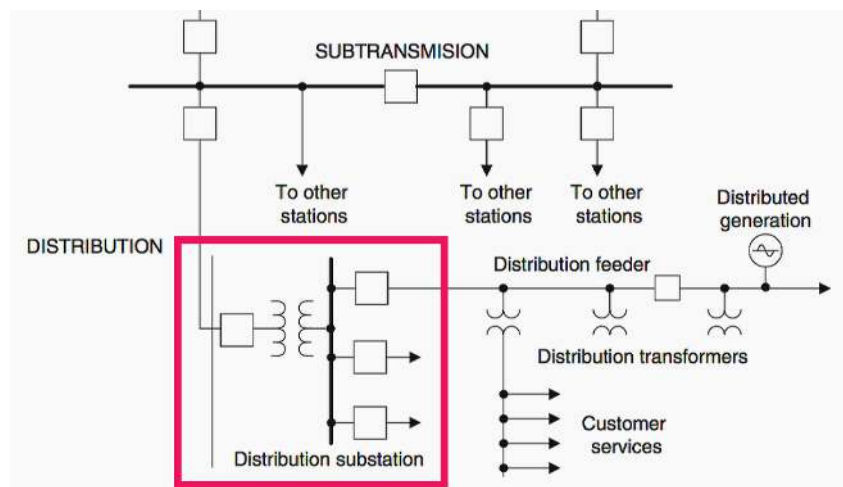

Figure 1: Distribution Substation Arrangement

The typical zone of protection includes the source sub-transmission feeder (s), the step-down transformer (s), the distribution bus, and each distribution feeder. The typical applications used by each zone includes.

1. Sub-transmission feeder: line differential or line distance schemes. Alternately for radial not tapped feeders a simple overcurrent protection scheme at the transmission station with zero sequence voltage protection at the distribution substation for transformers with delta high side winding.
2. Distribution Transformer: differential protection is typical with backup overcurrent.
3. Distribution Bus: one of high impedance, low impedance, or overcurrent differential scheme.
4. Distribution Feeder: Overcurrent protection, directional overcurrent is sometimes necessary. Auto reclosing for overhead lines and breaker failure protection for a stuck or slow breaker.

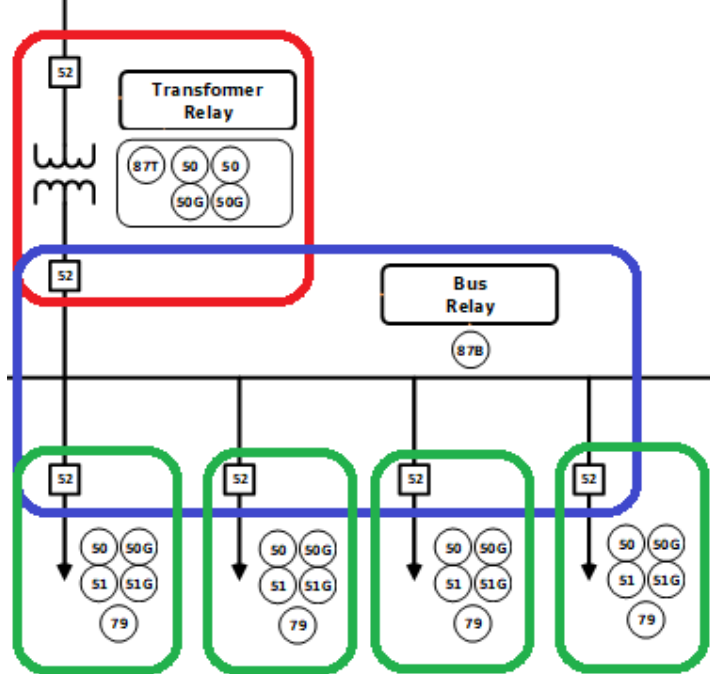
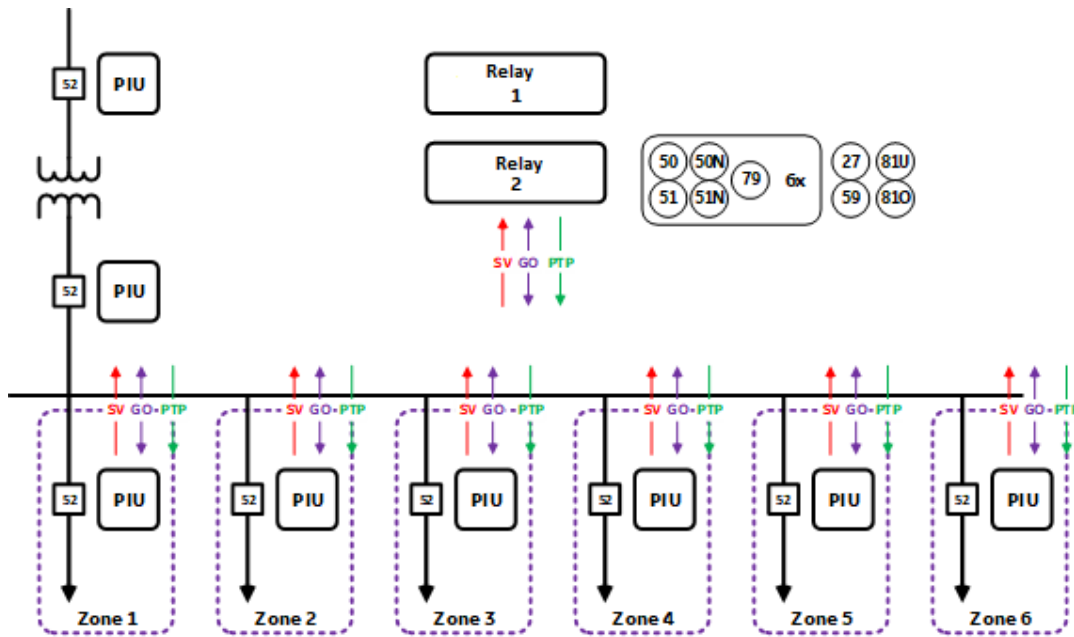

Figure 2: Distribution Substation Protection Scheme

Figure 2 is the protection scheme used in our real-world case. The focus here is re-designing this substation and transition towards a multi application relay scheme using IEC61850.

### 3. Multi Application Relays

A multi application or multi zone protective relay is described in its name: a relay intended to protect multiple types of protection applications simultaneously and independently. A typical multi application protective relay is shown in figure 3: a relay capable of protecting multiple distribution feeders simultaneously.



**Figure 3: Multi Application Protective Relay**

Though they have been commercially available for a while, multizone relays have not been commonly used due to the complexity of the copper field wiring. Every set of CTs for each feeder, every circuit breaker status point, and every circuit breaker control point requires a pair of copper wires, leading to a complicated and difficult wiring solution like Figure 4.



**Figure 4: Multi application copper wiring**

It is easy to see that IEC 61850 makes multi application relay a practical solution, by introducing distributed I/O through the concept of process bus. Sampled values (SV) messages replace copper wiring to instrument transformers, and GOOSE messages replace copper wiring for status and control of circuit breakers and other primary equipment. The physical limitation for a multi application relay of a limited number of terminal blocks changes to the number of SV messages (especially, due to bandwidth considerations) and number of GOOSE messages the device can subscribe to, and the number and types of protection elements the device has implemented.

Multi application relays have typically focused on distribution feeder protection due to the simplicity of, and the identical nature of, the protection functions. Other multi application relays may include transformer differential relays and bus differential relays with adequate protection functions to provide overcurrent protection for individual feeders. With the adoption of process bus, it is possible to use multi application relays to simplify the protection design of small distribution substations. Using the distribution substation introduced in figure 2 and applying a multi application relay with process bus the architecture in figure 5 can be achieved. For the feeders a multi application relay is used to protect all 4 feeders and another multi application relay is used to protect the bus and backup all the feeders. A multi application relay is used to protection the bus using a bus low impedance differential protection. This relay also simultaneous provides distribution feeder protection by incorporating phase and ground overcurrent and breaker failure backup protection applications. The second multi application relay provides phase and ground overcurrent protection applications for each distribution feeder. It also provides control applications including auto reclosing and breaker local and remote control.

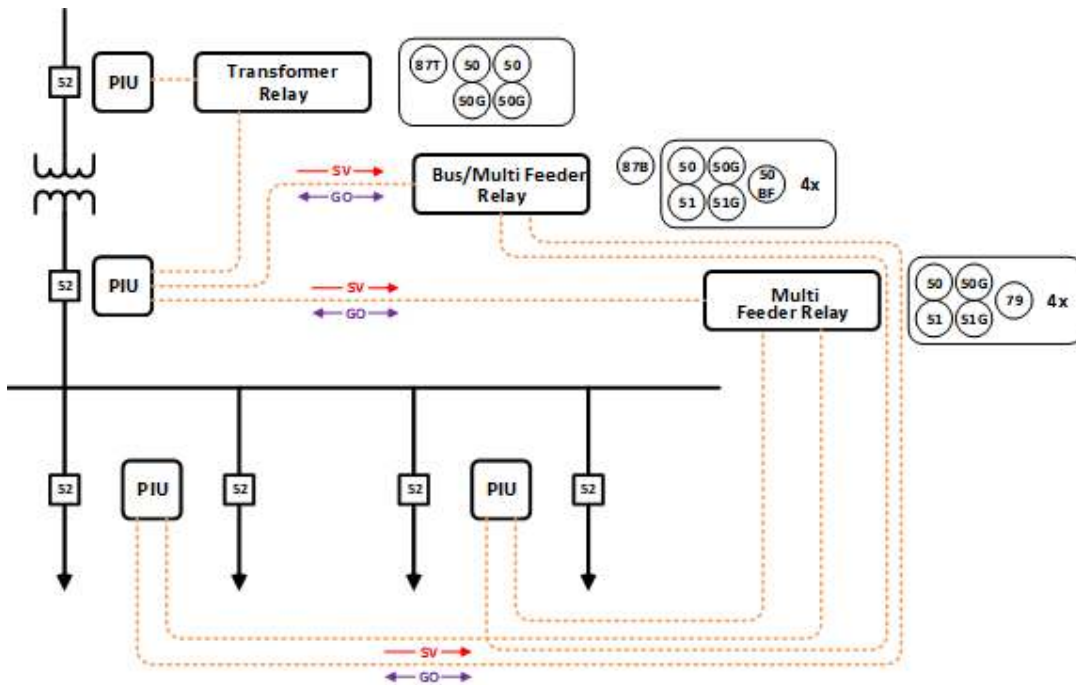

Figure 5: Distribution substation with multi application relays

### 3.1. PIU

The PIU of figure 5 is a process interface unit. A PIU combines the functions of a merging unit and an I/O device into one unit, as shown in more detail in 6. The PIU connects directly to instrument transformer secondaries, and publishing sampled values (SV) as per IEC 61850-9-2LE [2] or IEC 61869-9 [3] as inputs to the multi application relay. A PIU also connects to primary equipment status and control points, publishing and subscribing to GOOSE messages. Published GOOSE messages provide equipment status information and alarms to the multi application relays. Subscribed GOOSE messages provide control flags for tripping and closing circuit breakers from the multi application relay.

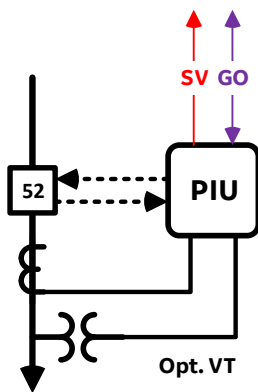

Figure 6: PIU concept

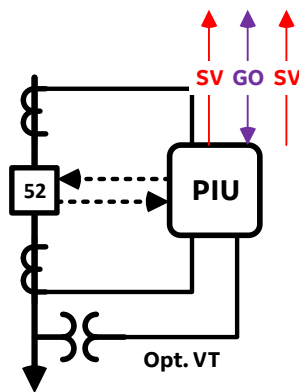

Figure 7: PIU with 2 measurements

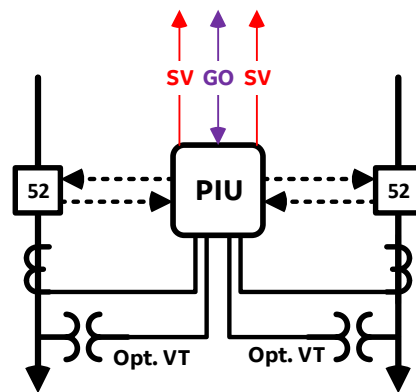

Figure 8: PIU shared between feeders

Some models of PIUs can publish more than one SV stream. When selecting a network architecture for the process bus system, it is important to understand the number of physical connections required along with the number of SV streams provided. Every SV stream takes significant bandwidth that must be accounted for in the system design.

Some models of PIUs can accept multiple sets of analog measurements. One possible application of such a PIU is as in figure 7, where a feeder uses CTs on both sides of a circuit breaker. Using SV streams as defined in 9-2LE requires that this PIU publish two SV streams. This PIU therefore uses one physical connection, but two SV streams, which may impact system design. Another possible application is to use one PIU to provide data from two different feeders as in figure 8. This one PIU per two feeders arrangement is used in the multi application distribution station of figure 5Figure .

### 3.2. Network considerations

Testing a process bus based multi applications relay system requires testing the PIUs and the multi applications relays. Process bus requires an Ethernet communications network between the PIUs and relaying units of some type. Many architectures for process bus are possible. The two most commonly used in distribution are point-to-point networks for small substations with a limited number of PIUs (normally 8 or fewer PIUs), and PRP (Parallel Redundancy Protocol) networks for larger substations and systems. This paper is focused on how to test the multi application relays and PIUs. The network and network design is assumed to be adequate for the protection system, but some understanding of networks is requires.

Point-to-point process bus directly and individually connects each PIU to the multi applications relay using a dedicated fiber optic link. This is the simplest architecture for process bus, as no switched Ethernet

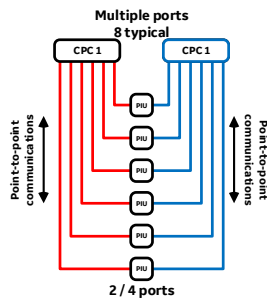

Figure 9: Point-to-point network

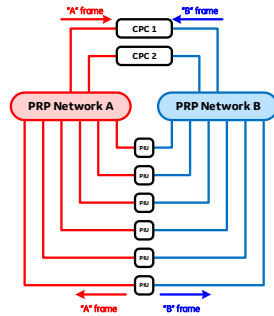

Figure 10: PRP networks

network is required. Point-to-point requires the relaying device have an adequate number of communications ports for connections to the PIUs, with 8 being a typical number. The device also needs the capacity to subscribe to a large number of SV streams, with 8, 16, and 24 streams typical numbers. PIUs should be able to connect to multiple multi applications relays simultaneously, requiring multiple communications ports. 2 and 4 ports are typical numbers of ports.

PRP is one of the two high availability network recovery protocols defined in IEC 62439-3. [4]

Devices supporting PRP use 2 ports to connect to 2 independent Ethernet networks. A publishing device publishes duplicate frames to both networks. Subscribing devices use the first of these frames they receive, discarding the second frame. If one frame is late or not received, the subscriber should receive the duplicate frame with a normal delay, so there is no difference in timing, resulting in zero recovery time on network reconfiguration or failure. PRP requires the addition of managed Ethernet networks, and all devices must support PRP. PRP was chosen for this network architecture given it's high availability.

### 3.3. Redundancy

Distribution substations are normally designed to be simple and especially cost effective, from a viewpoint of both capital costs and operating and maintenance costs. Distribution protection systems rarely use redundancy due to this cost sensitivity. However, a multi application process bus system changes the considerations around redundancy. Traditional systems use multiple relays and backup zones of protection to provide reliability, but with a multi application relay system the backup zones are in the same device. Therefore, redundancy of these systems is a good reliability practice. More importantly, having a redundant unit simplifies testing while reducing the risks of testing. And the project cost of this redundant unit is essentially the material cost of the unit. The unit is connected to the same networks and configured the same as the primary unit. So, redundancy of the central unit is possible at low capital cost and provides lower operating and maintenance costs.

## 4. Testing under IEC 61850

There are 2 critical concepts to understand when testing IEC 61850 systems, especially those using process bus. These are:

1. Isolating a device for test.

## 2. Creating controlled data for the device under test

These concepts have been more fully discussed in papers presented previously at this conference. See References [5] and [6].

### 4.1. Isolation under IEC 61850

Isolation under IEC 61850 is basically isolating the rest of the system from the device under test. The method for doing this is through the Mode of the device under test, and the quality flags of the data produced by the device under test. The Mode can be defined at the device level, the logical device (LD) level, or the logical node (LN) level. "Device" in the following discussion can also be meant to be "LS" or "LN", with the difference being how much of the device behaves in a specific way.

There are 5 modes under IEC 61850: ON, ON-Blocked, TEST, TEST-Blocked, and OFF. Each mode determines what quality of data and control commands the device responds to, and the quality of data published by the device. The responses of the device are described completely in Table A.1 and Table A.2 of IEC 61850-7-4. [7]

Placing a device in TEST changes the quality of all data published by the device to "test" data (q=test). Any device in the normal ON mode ignores this data, as a device in ON mode only accepts normal data (q=good). So, any data published by a device under TEST is ignored by any device in normal service. A device in TEST will accept both normal data (q=good) and test data (q=test), and make operating decisions based on this data.

### 4.2. Controlled test data under IEC 61850

IEC 61850 provides two methods for providing controlled test data. These are Simulation and substitute test data. Simulation is the far more practical method.

Simulation is a two-step process. A physical device must be placed into Simulation. Simulated messages, that exactly duplicate the live GOOSE and SV messages, must be created and published. Simulation occurs only at the device level. The physical device continues to use live process data for every subscribed message until an individual message subscription receives a simulated message. Once an individual message subscription has been simulated, this subscription uses only simulated data until the device is taken out of Simulation. This means a device in Simulation can use a combination of simulated data and live process data until every message subscription is simulated. Part of a good test procedure would therefore be to place a device into Simulation, and then immediately simulate every message. The general concept of Simulation is as in Figure.

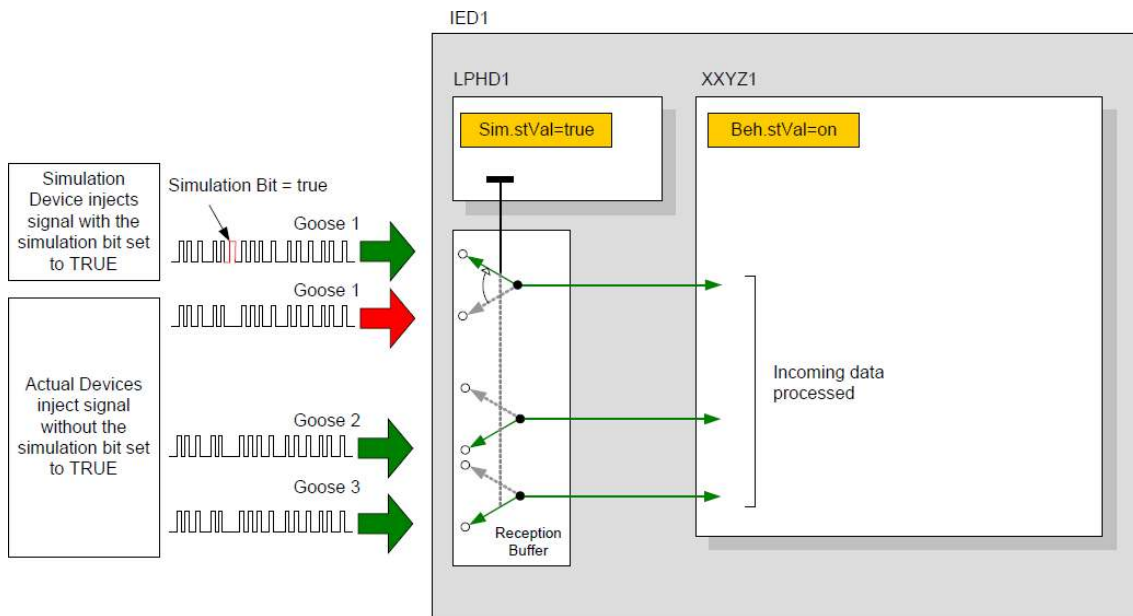

Figure 11: Simulation mode and message subscription [8]

Another method for controlling test data is to define specific test input signals during the design phase. Every LN may have one or more input references (InRef), an assignable input to the LN. An InRef has both a source reference input (SrcRef) and a test reference input (TstRef), as in figure 12. In a normal operating mode, the InRef uses the data assigned to the SrcRef input. Setting InRef.tstEna to “true” forces the LN to use the data assigned to the TstRef input. This data can be generic data, as long as the data types and attributes match the requirements for the InRef. This means that this TstRef data and the messaging to carry the data must be defined during system design. This method works only with InRefs, and only at the LN, not device level. To use this substitute data, all of these test inputs must be designed and configured as part of the overall system configuration. In all but specific circumstances, simulation will be a more practical method of providing controlled test data.

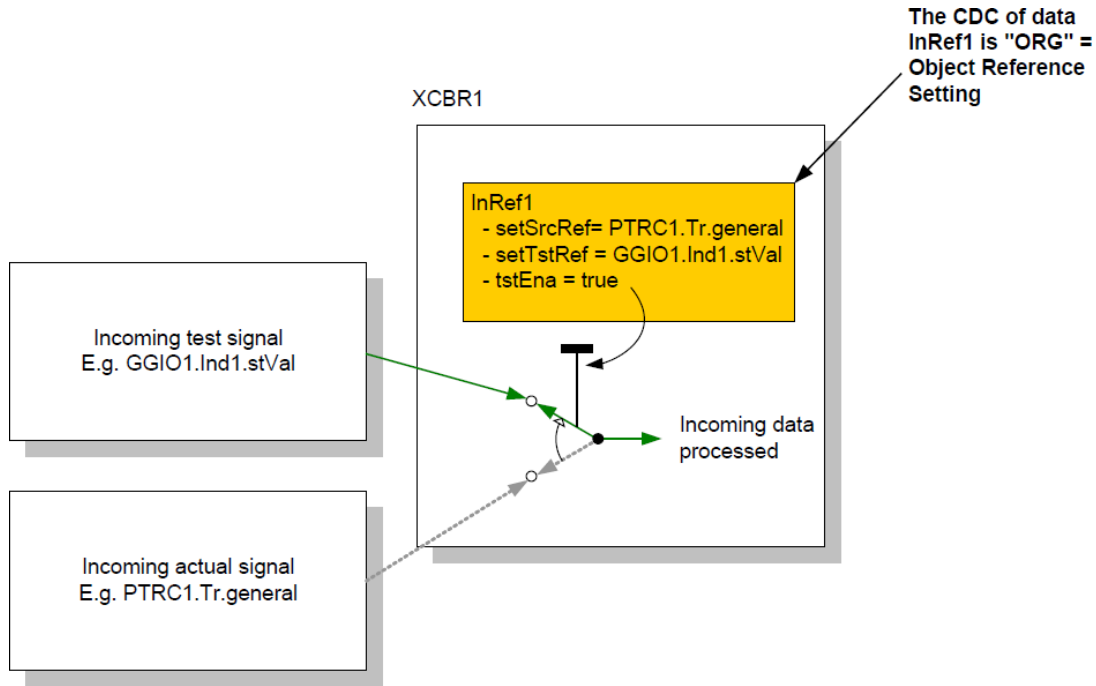

Figure 12: Using TstRef with InRef [8]

The combination of these Test Modes and Simulation greatly simplify commissioning and testing protection and control systems, including the ability to test parts of the system while the rest of the system is still live. A comprehensive description of testing IEC 61850 substations is in CIGRE Technical Bulletin 760, “Test strategy for Protection, Automation and Control (PAC) functions in a fully digital substation based on IEC 61850 applications”. [9]

### 4.3. IEC 61850 testing tools

It is possible to test process bus systems using standard relay test sets and test methods, especially during commissioning, by using substitute test PIUs and relays connected to standard relay test sets. However, this is generally a sub-optimal method of testing and is normally used as a bridge method until a utility develops the expertise around testing IEC 61850-based systems, especially those using process bus.

The assumption in testing multi applications relays is that testing tools designed to work directly using IEC 61850 will be used. These testing tools will connect directly to the process bus network in the substation. When testing PIUs, these tools will connect and drive the analog inputs to the PIU and subscribe to SV and GOOSE messages from the PIU. When testing the relays themselves, these testing tools will publish the SV and GOOSE messages expected by the relays. This requires the testing tools to be able to simulate fault events. Obviously, for these tools to be effective, they must accept and use the substation configuration files (SCL) used in the IEC 61850 configuration of the substation and devices.

## 5. Test strategy for multi-application relays

There are two basic types of testing required for a protection and control system for a substation. The first is commissioning testing, which is verification that the protection system is installed correctly, all devices are operating correctly, and that devices are configured correctly for the application. Commissioning normally takes place during the construction of a new substation, or the significant refurbishment of the control system of an existing substation.

The second type of testing is maintenance or in-service testing of protection systems. This testing is performed to prove devices are still operating within defined performance parameters, or when changes to device configuration or protection element settings are made. For a process bus system, only the PIUs may require regular maintenance testing. The relaying unit is a fully digital device, with complete self-monitoring, and doesn't require testing. However, the relaying unit may need testing if the element settings for a specific zone of protection are changed due to changing system conditions or changing feeder circuit configuration.

However, the general strategy for testing a protection and control system for a distribution substation using multi application relays and process bus is the same for both commissioning and maintenance testing. The protection and control system consists of 2 separate subsystems: the PIUs, and the relaying unit itself. The overlap and interconnection between these subsystems are the IEC 61850 messaging, the SV and GOOSE messages, between these devices. The actual overlap is the Control Block header information that is used to uniquely identify the messages. So once a PIU and a multi application relay is proven to be configured correctly, the whole system will be correct, since the outputs of one device are the inputs to the other. This means that the PIUs and the multi application relays should be considered separate devices for testing purposes. Therefore, the golden rules for testing a distribution substation using multi application relays are:

1. PIUs and multi application relays are separate devices, and should be tested as such
2. All testing that can be done as part of factory acceptance tests (FAT) should be done as part of a FAT
3. Only commissioning a new substation or protection and control system refurbishment requires a system check.

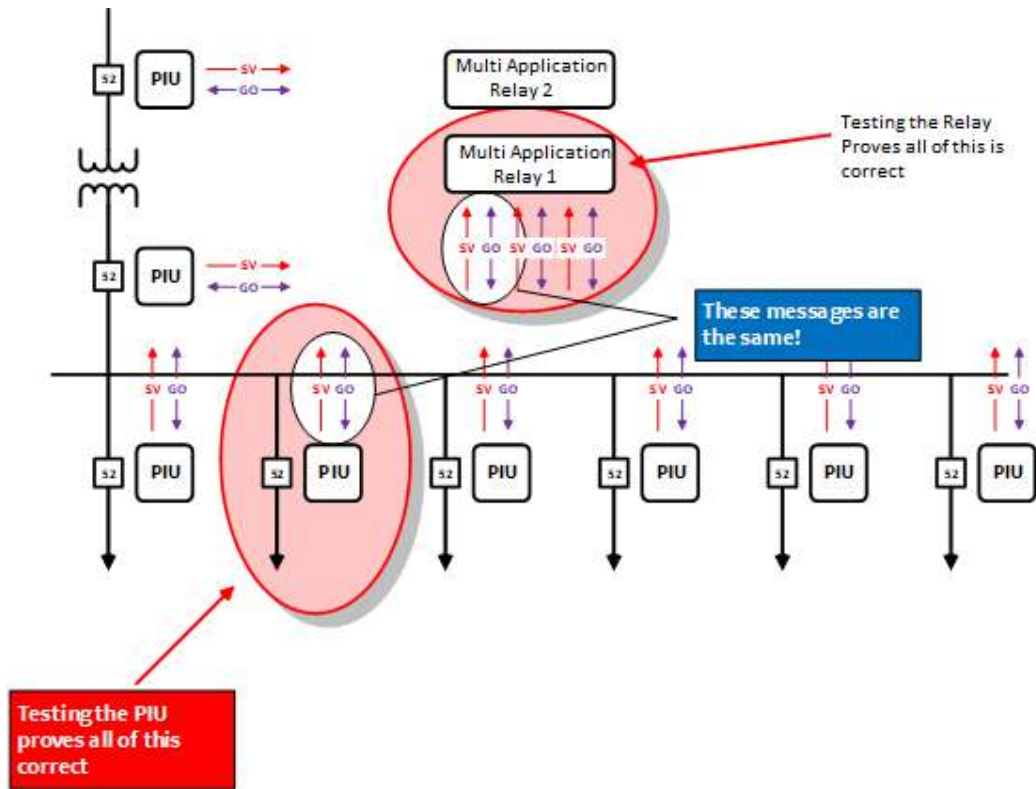
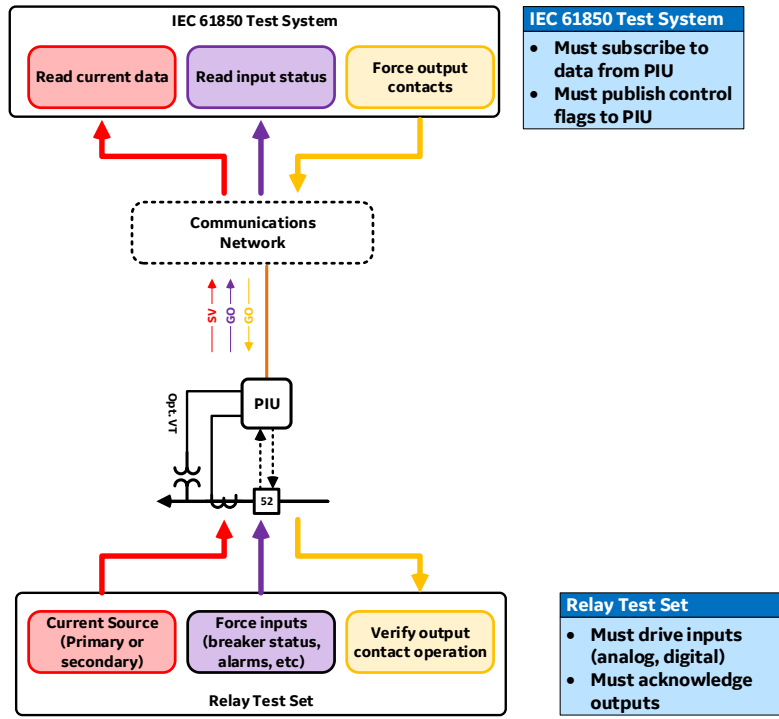

**Figure 13: Testing as subsystems**

Treating the PIUs and multi application relays as separate systems to test is the most efficient way of testing. During commissioning testing this will result in great savings in testing effort, particularly testing time on site.

### 5.1. Testing PIUs

Testing a PIU is very similar to testing a conventional microprocessor-based relay. The wiring interface to the PIU must be proven correct, the operation of the PIU must be proven correct, and the configuration of the PIU must be proven correct. The testing to prove the wiring and the general operation is very traditional: inject current and voltage to prove the analogs and force the digital inputs and outputs using standard relay testing tools. Proving the configuration of the PIU requires the use of IEC 61850 testing tools. These tools must be configured to subscribe to the data published by the PIU and configured to publish control flags to the PIU through GOOSE messages. This testing tool must know the configuration of the PIU, available from SCL files.

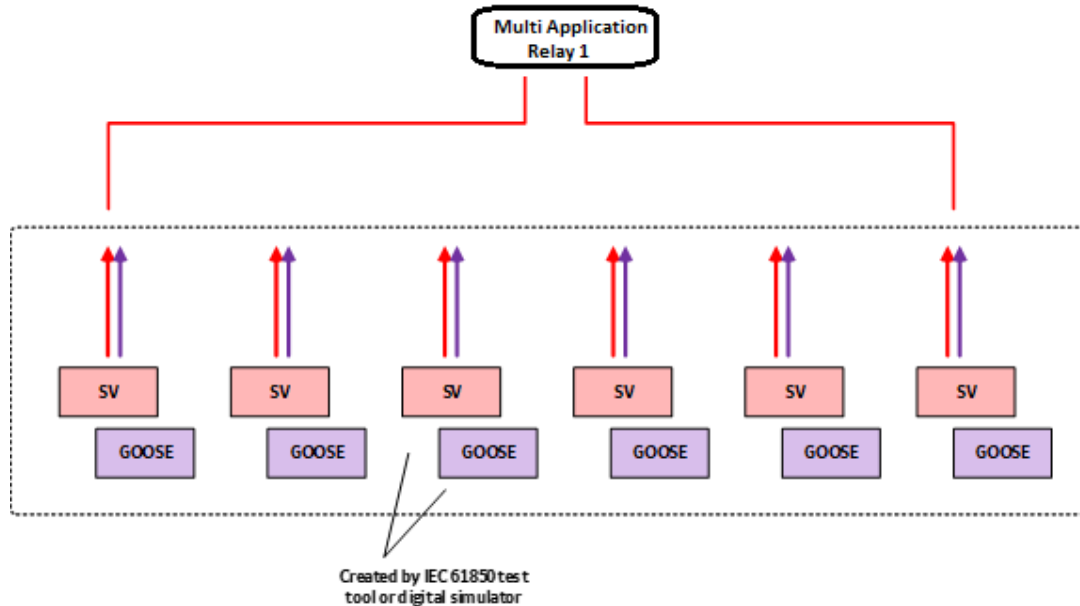

**Figure 14: Testing a PIU**

This generic test methodology is shown in figure 14. There are modifications to this method depending on whether the testing is a FAT, a site acceptance test (SAT), or maintenance testing.

**5.2. Testing multi application relays**

The testing of the multi applications relays should always be done as a FAT, whether this is for a new protection and control system, or for settings or configuration changes in an existing, in-service unit. This FAT does a complete test of the protection system, including all protection element settings and configuration.



**Figure 15: Testing multi applications relays**

This full testing as part of a FAT is possible because the inputs to the central device are the virtual inputs of SV and GOOSE messages. An IEC 61850 testing tool can use the SCL configuration of the central device and PIUs to easily produce the same messages required by the actual installation. This tool will be able to use the substation IEC 61850 configuration to create the appropriate messages, as well as publish SV and GOOSE messages to simulate actual fault conditions. Multi application relays should always be tested in this manner. For a new substation or protection and control system, this FAT will be done at a control building/panel builder OEM. For changes to existing substations, this FAT will be done in a laboratory environment, where the test tool could be a digital simulator.

## 6. Commissioning Testing of Multi Application Relays

Commissioning a substation based on multi applications relays is actually more efficient than commissioning a conventional substation because the PIUs and relaying devices can be commissioned separately, and mostly commissioned as part of FATs, in our case the FAT is done in the lab environment to not only test but prove out concepts.

The general commissioning process is as per 6. This process has 5 basic steps: FATs for the PIUs and multi applications relays once they are available, site acceptance tests (SATs) of the PIUs and multi applications relays once they are installed, and a final system checkout commissioning. This general process can be adjusted between new substations and retrofit of existing substations.

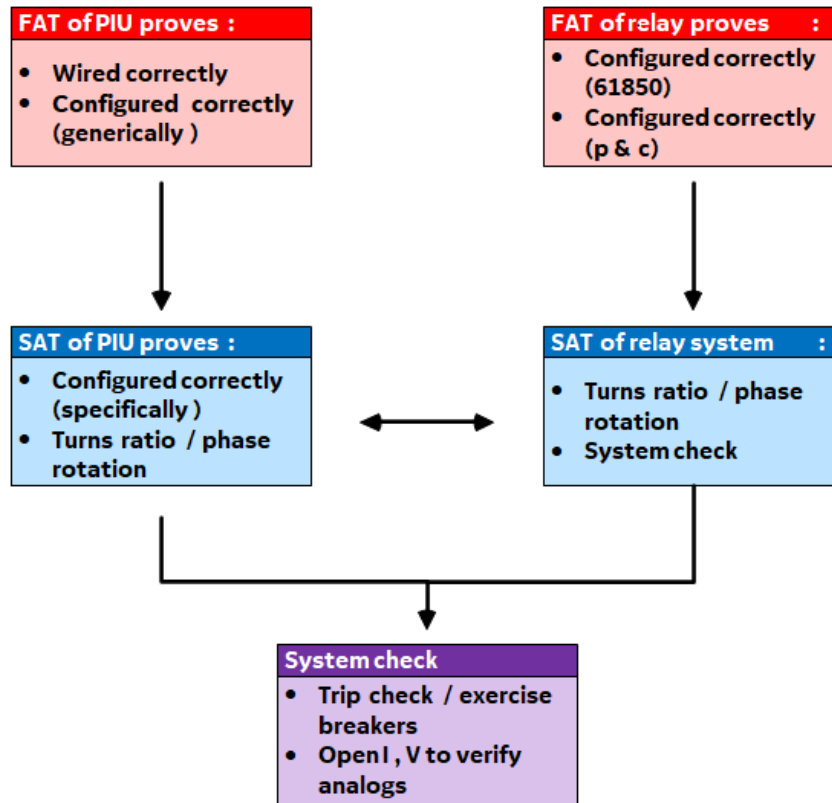

Figure 16: commissioning process

The FATs of the PIUs and the multi application relays prove the general configuration of the devices. However, there is still some project specific information that must be updated and proven. Specifically, this is the final configuration of control block header information in the PIUs, the connected turns ratio of instrument transformers, and the phase rotation of the analog measurements.

### 6.1. FAT/LAB Testing of PIUs

For new construction, the majority of PIUs should be installed at the primary equipment by primary equipment OEMs. The basic configuration of the PIUs should use standard datasets for SV data and for GOOSE messages. The PIUs should also use a standard wiring design. The header information in the SV Control Blocks and GOOSE Control Blocks will be generic during the FAT, so every PIU can be tested using the same test set up and test device.

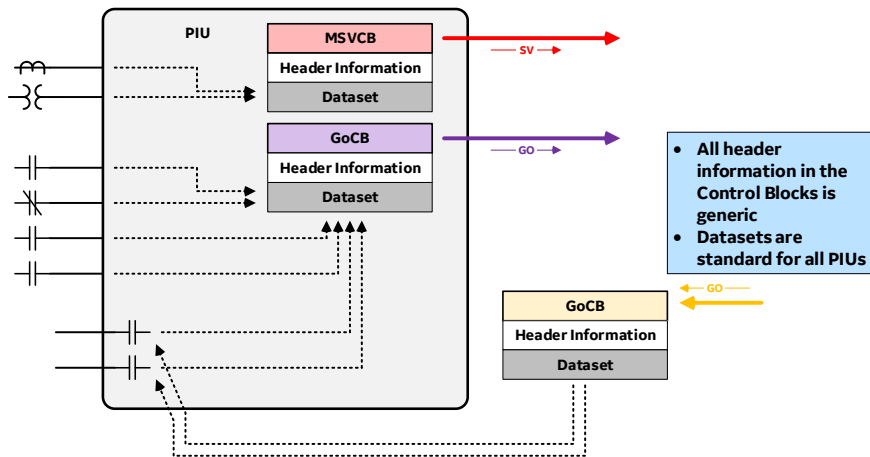

Figure 17: FAT of PIU

This test setup can be quite simple. It can consist of a relay configured to work with the generic configuration of the PIU and requires only primary or secondary injection of currents and voltages, and the ability to exercise circuit breakers and circuit breaker alarms and status indications. After testing, the wiring, configuration, and operation of the PIU is verified.

The only steps left for the SAT of the PIU is to update the header information in the SV and GOOSE Control Blocks; and to update the connected turns ratio settings for the instrument transformers, and possibly the phase rotation of the measured analog values.

### 6.2. FAT/LAB Testing of multi applications relays

The testing of the multi applications relays should be done as a FAT as soon as the relay panels or control building is complete. This FAT does a complete commissioning test of the protection system, including all protection element settings and configuration. This FAT fully follows the process described in Section 5.2 and Figure.

### 6.3. SAT of PIUs

The SAT of the PIUs can happen once they and the associated primary equipment are installed on site. The PIU configuration needs to be updated with the correct, specific, header information for the SV and GOOSE control blocks. The configuration also needs to be updated with the actual connected turns ratios for the instrument transformers the PIU is connected to. After the SAT, the PIU will be proven to be configured correctly. For this type of testing, an IEC 61850 specific testing tool is the best choice. No injection testing needs to occur, just verification that the messaging is correct.

The SAT needs to determine the power system phase connections between the instrument transformers and the PIU. A PIU installed by a primary equipment OEM will generically connect an instrument transformer from one bushing to the A-phase PIU input, from the next bushing to the B-phase PIU input, and from the third bushing to the C-phase PIU input. Once installed on site, these bushings will be connected to the power system, which may be different phases with a different rotation. Phase rotation can be adjusted by rewiring the PIUs, which is not recommended. The phase rotation of the SVs can be adjusted in the subscribing multi applications relay, which is the preferred method.

### 6.4. SAT of multi applications relays

The SAT of the multi applications relays is driven by the final system check. The device needs to be updated with the connected turns ratios of all the instrument transformers connected to PIUs. Also, the device needs to adjust the phase rotation of subscribed SV data to match that of the actual power system. At this point, communications between the multi applications relays and the PIUs can be verified by simple visual checks of communications alarms, through Ethernet traffic monitoring tool, or through IEC 61850 dedicated.

### 6.5. System check

The system check is a final confidence commissioning test to verify that the multi applications relay is publishing control flags to the correct PIU. This check can simply be forcing the operation of circuit breakers, both open and close, from the central unit.

There also needs to be a final check of the analog values, to ensure the instrument transformer turns ratio are correct in both the PIU and central unit, and to ensure the phase rotation is correct between the PIU and the central unit. This check can be a simple visual metering check. It can also involve opening test switches at the PIU one phase at a time and observing the results at the multi applications relay. This is one test that must be done based on the interaction between PIUs and the central unit.

## 7. Maintenance testing of multi applications relays

Only PIUs require regular maintenance testing, as they are the only device that contains analog interfaces that are not fully monitored. Testing a multi application relay is only required when there are settings changes to protection elements or other configuration changes.

### 7.1. Testing a PIU

The PIU is the digital to analog interface to the primary equipment and as such has all the physical I/O for the protection and control system. This physical I/O should be tested at regular intervals to ensure the device is still operating correctly within desired performance parameters. There are two subsystems that may require testing. The first is the output contacts, which must be tested to ensure they still operate and energize circuit breaker operating coils. The second is the analog current and voltages inputs, where it is likely desirable to ensure they are performing correctly.

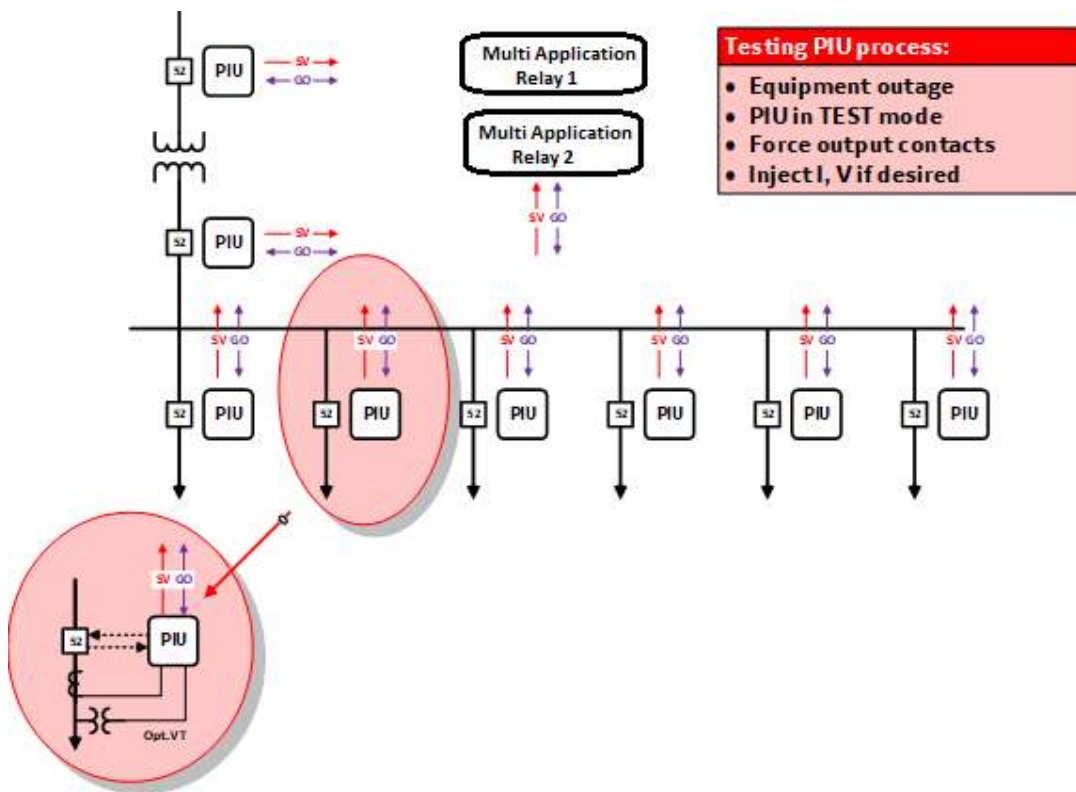

Figure 18: Testing a PIU

Maintenance testing of a PIU, for either testing the output contacts or the analog inputs, almost assuredly requires an equipment outage. This is to prevent undesirable operation of protection elements during testing, and to allow the exercise of the circuit breaker if desired.

Maintenance testing of a PIU is based on the standard testing procedure of Section 5.1 and Figure, with specific modifications for in-service systems. The test setup is to gain an equipment outage for the feeder or zone associated with the PIU under test, then place the PIU in TEST mode. In TEST mode,

the PIU will still accept control flags from the multi applications relay, but all data published by the PIU will be test data (q=test) that will be ignored the protection device or any other device that is in normal ON mode. The process is then the same as in Section 5.1: exercise the analog and digital inputs from the relay test set and force the digital outputs from the IEC 61850 test tool.

Testing output contacts can theoretically be done without an equipment outage. Place the PIU in ON-Blocked or TEST-Blocked, to prevent the circuit breaker from operating, and look at the feedback from the PIU after receiving the control flags. Or use test switches to isolate the control circuits from the PIUs and monitor the state of the output contacts. Testing contacts without an equipment outage carries the low risk of a fault occurring on the feeder under test during the test, resulting in slow clearing of the fault by backup protection.

**7.2. Verifying settings changes in a multi application relay**

The only time testing of an in-service multi application relay is required is when there are significant changes to configuration. Figure is an example of where such testing is required, as circuit changes require new protection settings for Feeder 5. This type of testing should still be performed using the FAT testing method of Section 5.2 and Figure.

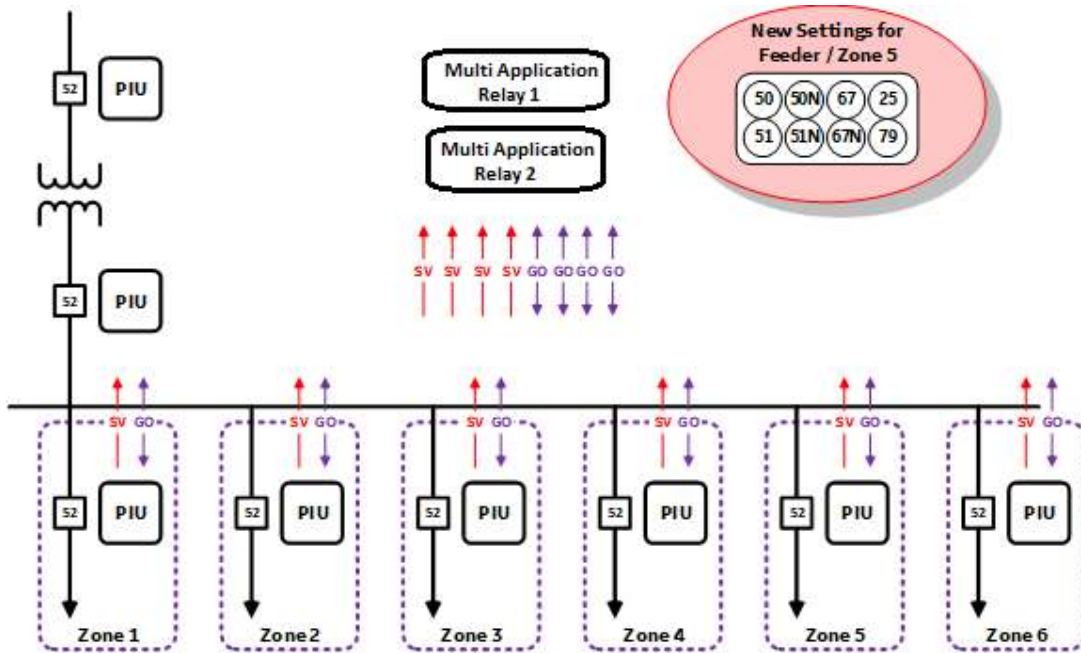

**Figure 19: Verifying settings changes in a multi application relay**

This method is the preferred method because it eliminates almost all testing risk and takes full advantage of protection and control system built around process bus. All of the field inputs to and field outputs from the multi application relay are digital signals contained in SV and GOOSE messages. The communications between the multi application relay and PIUs were proven during commissioning, and at this point, by operating experience. The only changes will be to the performance of the unit itself, not to the messaging between PIUs and the multi application relay. The performance of this configuration can be easily tested in a laboratory environment, where the field inputs and outputs are created by IEC 61850 testing tools.



**Figure 20: Laboratory verification process**

The general process for this testing is that of Figure. Retrieve the configuration files from the actual field multi application relays. Any changes to settings are made from these retrieved files. The use of these retrieved files ensures that the SV and GOOSE messaging configuration remains unchanged and is correct for this device. Once protection element settings are updated, this new configuration file is

loaded into a laboratory multi application relay that is exactly the same as the field unit. Testing / verification is carried out by simulating fault events with an IEC 61850 testing tool that produces the correct SV and GOOSE messaging for the substation. Once this new configuration is tested and proven, the process is to load this new configuration into the field multi application relay. This unit should be in TEST mode while the new configuration is loaded, and a simple verification test is used to ensure data is being received.

This process can be used if there is a single multi application relay or redundant multi application relays. Redundant units are recommended because the process risk is much lower for this method of testing, or for any other method of testing. Loading the new, verified configuration can be done in one unit that is completely removed from the process bus network, and in TEST mode. Once the new configuration is installed in this unit, it can be reconnected to the process bus network. A quick visual verification will show that all communications and messaging is still valid, and there are no alarms or operations. The device can then be removed from TEST mode, and this process can be repeated for the second unit.

This laboratory verification method of new settings and new configuration is by far the lowest risk method of testing a system with only a single multi application relay.

### 7.3. Testing a Multi application relay with redundancy

Even though laboratory verification of new settings is the preferred method of testing, there may be some circumstances when testing multi application relays in the substation is desirable. Proving connections to other devices and systems, such as communications with downstream reclosers is one case. This may also be simply hesitation to change traditional test philosophies. The method for testing a multi application relay is different when there are redundant units versus a single unit. It is strongly recommended to use redundancy, as this simplifies the test process, and reduces risk during testing. One unit can be fully tested, while the other unit is still in-service and providing protection.

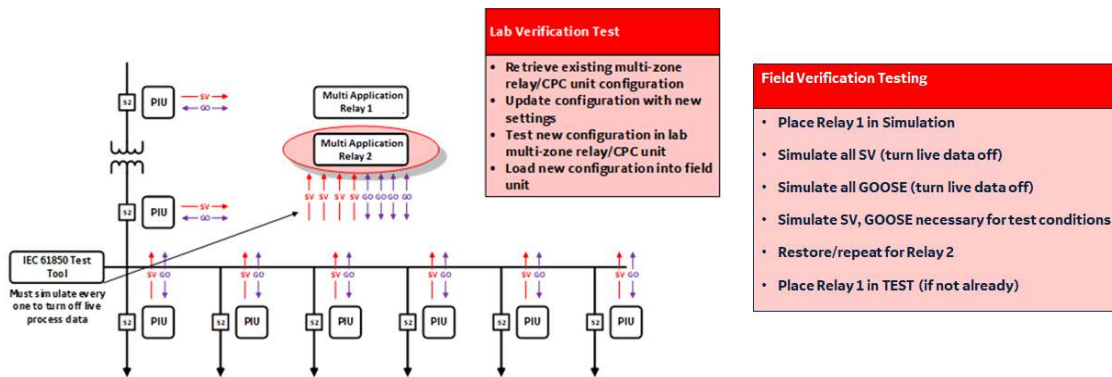

Figure 21: Testing a redundant multi applications relay substation

With redundant multi application relays, one of these units should always be in TEST mode, to operate as a hot standby device and prevent control confusion when operating circuit breakers. To setup the test of the device, start the testing process with the device already in TEST mode. If one of the units is not in TEST mode, then place one of the units in TEST mode. This ensures all data published by the device will be test data (q=test) and will be ignored by the in-service devices in ON mode. Then place this device in Simulation, so it will accept simulated SV and GOOSE messages. [6]

A device in Simulation will use live process data for every subscribed SV and GOOSE message until it receives simulated data (a message where the simulation bit is True) for a specific message. Then for this message only, the device will only accept simulated data. Testing requires controlled data, so it is necessary to turn off all the live process data by simulating all the SV and GOOSE messages. Depending on the test tool used, this may require simulating SV and GOOSE messages one at a time to turn them all off, or this could be done in batches of SV and GOOSE messages. Testing is then performed by having the testing tool simulate fault events, publishing simulated SV and GOOSE messages, and verifying the new protection element settings. Once the testing is complete, the device is taken out of Simulation to start using live process data, then returned to ON mode. This process is then repeated with the other multi application relay.

Once testing is complete, the PIU is placed in normal ON mode, the multi application relay is taken out of Simulation, and the LD is placed in normal ON mode.

#### **7.4. The IEC 61850 multi application testing conundrum**

The test method of Section **Error! Reference source not found.** works when all the source data for a protection zone: the currents, voltages, and equipment status, is contained within the zone. Once data is required from another zone, this testing method no longer works. The example shown in figure 19 shows the need to test functions like directional overcurrent and synchrocheck, that require both a feeder voltage from the PIU and zone under test, and a bus voltage from a different PIU. Simulating the bus voltage can't be done. Simulation under IEC 61850 is at the device level only. Simulating the bus voltage effectively turns off the live voltage data for the other protection zones that are still in service. Testing may result in undesirable operations. Conversely, it may be possible to test synchrocheck and directional overcurrent using the actual live bus voltages, but this is uncontrolled data and results in a suboptimal test.

The solution for this under IEC 61850 is to use substitute test data for individual LNs, as described in Section 4.2 and Figure . This method allows the switching of the input data for a LN from the normal data to data from a predefined test reference source. In practice, this solution is not practical. It increases the number of configuration points in the multi application relay, requires the ability to control the state of the inputs, and requires predesigned test SV and GOOSE messages that must be subscribed to. Test procedures then require publishing these test messages and changing the attributes of the inputs to use this test data. This is a complex solution and to date, no commercially available device supports this method for SV data.

The recommendation then is that the correct testing method for single multi application relays is the laboratory verification method.

## **8. Summary**

Multi applications relays integrated with process bus are now available for distribution substations. The use of these devices greatly simplifies the design of the protection and control system and lowers the effort and cost to design and build these stations. However, these systems introduce some questions and challenges around testing. Commissioning with multi application relays is simpler, more efficient, and less risky than commissioning a substation with conventional relays. Maintenance testing of PIUs is very similar to testing a conventional microprocessor-based relay, and testing methods can be quickly adapted and implemented.

The challenge to testing is with the multi application relay itself. Testing this unit and configuration is only necessary when there is significant configuration or setting changes. It is likely the settings for a single zone of protection will be changed, and these changes will need to be tested and verified, while the rest of the system stays in service. The best method is to verify these changes in a laboratory environment, then pushing the new configuration to the field devices. If testing must be done in the field, then having redundant multi application relays makes this testing straightforward and with low risk. Having only a single multi application relay results in a less than optimal test procedure and should be avoided.

## **9. References**

- [1] R. Hunt, J. Coursey and S. Hirsch, "Simplifying Protection System Design for Distribution Substations," in *Georgia Tech Protective Relay Conference*, Atlanta, GA, 2012.
- [2] Implementation Guideline for Digital Interface to Instrument Transformers Using IEC 61850-9-2, Raleigh, NC: UCA International Users Group, 2004.
- [3] IEC 61869-9:2016 Instrument transformers –Part 9: Digital interface for instrument transformers, Geneva, SW: IEC, 2016.
- [4] IEC 62439-3:2016 Industrial communication networks – High availability automation networks – Part 3: Parallel Redundancy Protocol (PRP) and High-availability Seamless Redundancy (HSR), Geneva, SW: IEC, 2016.
- [5] C.-P. Teoh, R. Hunt and C. Pritchard, "Testing Busbar Protection (BBP) Systems Using Process Bus Technology," in *2019 PAC World Conference*, Edinboro, Scotland, 2019.

- [6] J. Saunier, S. Vigouroux and R. Hunt, "Use of IEC 61850 Test Capabilities to Implement Hot Standby Systems," in *PAC World Americas Conference*, Raleigh, NC, 2019.
- [7] IEC, IEC 61850-7-4:2010 Communication networks and systems for power utility automation – Part 7-4: Basic communication structure – Compatible logical node classes and data object classes, Geneva, Switzerland: IEC, 2010.
- [8] IEC, IEC 61850-7-1:2011 Communication networks and systems for power utility automation – Part 7-1: Basic communication structure – Principles and models, Geneva, Switzerland: IEC, 2011.
- [9] CIGRE Working Group B5.53, "Technical Bulletin 760, Test strategy for Protection, Automation and Control (PAC) functions in a fully digital substation based on IEC 61850 applications," CIGRE, Paris France, 2019.
- [10] IEEE Power System Relaying Committee Working Group, "Centralized Substation Protection and Control," IEEE, New York, NY, 2015.
- [11] C. Teoh, R. Hunt, G. Rebollar and G. Lloyd, "A centralized protection and control system using a well proven transmission class protection relay," in *PAC World Americas Conference*, Raleigh, NC, 2019.
- [12] *Disribution Systems, Substations, and Integration of Distributed Generation* by John D. Mcdonald, Bartosz Wojszczyk, Byron Flynn, and Ilia Voloh

## Biographies

**Ravindranauth Ramlachan** (Mike) is a Lead Sales Application Engineer at GE Grid Solutions (former Alstom) in North America. His primary role with GE is key customer contact for technical issues including protection and control application support pre and post sales. Prior to joining Alstom/GE he worked at Consolidated Edison of NYC in various positions. Several of which were in the Relay Protection Engineering department performing protection system design, fault and coordination studies, fault analysis, and developing relay settings. Two years were in the Protective Systems Testing department performing relay system testing. He has a master's degree in electrical engineering acquired from Stevens Institute of Technology.

**Glenn Wilson** [bio pending]

**Jim Campbell** [bio pending]