

High-Impedance Faults: Comparing Algorithms

Daniel Ransom, PE, GE Renewable Energy

Abstract— It remains a great challenge to identify an arcing, downed conductor. Detecting and removing power from fallen wires is very important for safety of property and human life. Recent events in California have spurred the effort to protect against the destruction caused by this situation. The challenge is that a downed conductor exhibits an intermittent, high-impedance, low-current signal that is difficult to sense for conventional relay protection elements. Over the years, protection engineers have developed algorithms for recognizing these high-impedance (Hi-Z), or high-impedance-faults (HIF) events.

This paper describes algorithms used for detecting an arcing, downed conductor. Comparisons and benefits of each of these algorithms, and settings methods, is presented. Also described is testing of these algorithms, including the test methods and results. Lastly, there are recommendations for employing HIF protection schemes, including tripping and alarming for high-impedance faults.

Keywords—*arcing, downed conductor, HIF, high-impedance fault*

I. INTRODUCTION

The following topics comprise the discussion of high-impedance faults (HIFs):

- Definition and causes of high-impedance faults
- Methods for HIF detection
- Method comparisons
- Implementation strategies

This paper covers these topics, to provide an understanding of the challenge and successful detection of HIFs.

II. DEFINITION AND CAUSES OF HIGH-IMPEDANCE FAULTS

A high-impedance fault (HIF) occurs when a primary conductor makes unwanted electrical contact with a tree, pole, structure or with the ground, and there is a large impedance restricting the flow of electrical current. The fault current can be at a few milliamps to 100 amps primary, much smaller than the current that standard overcurrent elements can detect. Even in cases where the instantaneous fault current exceeds standard overcurrent thresholds, the duration of this transient event is so short that standard fuses and overcurrent elements will not clear or pick up. There is little threat of damage to power-system equipment from these transient events, but these events are a safety and fire hazard. Line crews responding to a downed or broken conductor event seldom document these as such on trouble reports. It is quite challenging to detect HIFs; it requires special methods, combining multiple techniques.

Downed and broken conductors are the causes of high-impedance faults. The conductor touching the ground might be intact, or, it could be broken. If the conductor touches the ground or other surface, and remains intact feeding a load, then we call this a “downed conductor.” Note the tension on the wires in Figure 1. This can be caused by support failure, heavy-loading sag, or an object (tree) on the distribution line.

Weather, nature, and faulty equipment can cause this problem. Icing and tree limbs leaning on distribution circuits cause lines to sag and to conduct current intermittently to ground. If a utility does not do an adequate job of clearing vegetation around distribution lines, then tree limbs touch the line irregularly, causing arcing on intact conductors.

Contaminated and failing equipment, such as disconnects, fuses, and dirty insulators can cause high-impedance faults in the distribution system.



Fig. 1. Downed conductors

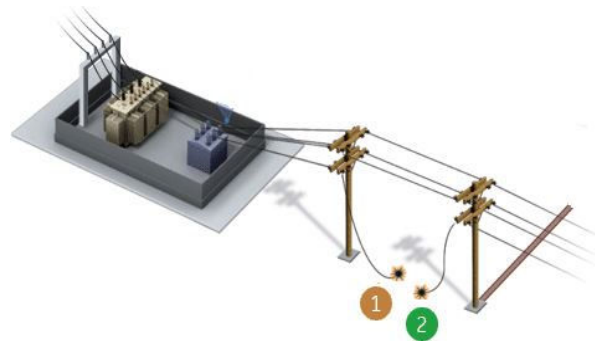

Fig. 2. Broken conductor

An HIF event that occurs often is when a conductor breaks and falls to the ground. When broken and laying on the ground, we call this a “broken conductor,” as shown in Figure 2. Note that the ends are separated and slack. The break drops load on the affected feeder, and sometimes, a momentary overcurrent condition occurs as the falling conductor comes in contact briefly with an adjacent line or a solidly grounded object. There is little effect on the system voltage.

Fault arcing and currents differ on various surfaces. Tests indicate that 60–85 percent of all downed conductors can be detected. This means that the remainder cannot be detected, because not all surfaces produce arcing. Without arcing, HIF (or Hi-Z) detection is unable to declare a downed conductor. For example, downed conductors on dry asphalt and dry sand cannot be detected because these surfaces do not produce arcing. However, it is difficult to find purely dry asphalt and dry sand with no moisture and impurities—the materials that would provide a conduction path. In contrast, reinforced concrete (lots of metal rebar) provides the most arcing. Many utilities have performed staged-fault tests on their systems to test the effectiveness of HIF detection. In

most cases, the utility includes a “challenge” test case. Typically, a conductor is dropped on asphalt or sand. In one test, the conductor was dropped on asphalt with the expectation of no detection. What occurred, however, was that the arc found paths through cracks in the asphalt that permitted arcing and subsequent detection by the HIF device.

Once on the ground, the resulting electrical signature is a function of the contacted surface. Surfaces such as concrete, grass, dirt, and wet surfaces in general result in an “arcing fault” with RMS fault currents in the range of 1–100 amps, whereas surfaces such as dry sand and asphalt result in a zero to constant, low-level current flow. Ground-path resistance varies during the arcing fault. The changing current creates non-linear waveforms. The non-linearities produce large harmonic and non-harmonic energy in the frequency spectrum of the current. This is an important factor in detecting high-impedance faults. Arcing generates significant noise on the affected feeder; spectral analysis reveals large harmonics and non-harmonic noise to approximately 700 Hz. Arcing faults result in definable and detectable patterns. However, surface types change the arcing-burst signatures, which presents a challenge to secure and dependable detection.

Arcing time for HIF currents is erratic; usually these currents decrease over time because the wire-contacted material burns. Arcing can stop for minutes, and then start again. High-impedance faults can persist from seconds to minutes, and sometimes for days!

III. METHODS FOR HIF DETECTION

With wide variations in types of material that an arcing line touches, the high-impedance fault signature changes, making HIF detection difficult. While no single parameter classifies an HIF, there are sufficient similarities among HIF incidents to have good success at detection. Over time, we have developed different measures and strategies to detect HIF conditions. Using multiple detection algorithms, it is possible to detect 60–85 percent of high-impedance faults.

In addition, it helps to supervise HIF detection with power-system load events such as a sudden load loss, or a sudden increase in second-harmonic current (from transformer inrush).

Ideally, HIF detection should detect all HIFs and should be secure, while ignoring normal conditions. It should be immune to false-positive indications and misoperations. HIF detection must differentiate between HIF current signatures and the waveforms from intermittent, noisy loads. Examples of loads that generate power-system noise are arc furnaces, welders, capacitor and line switching, load-tap changing, DC rectification, motor commutation and starting, etc. Effective HIF detection techniques evaluate and subtract load from the arcing algorithm.

Detecting HIF is vitally important. Undetected, live, downed conductors can be fatal to the public and to line crews. Arcing from high-impedance faults cause fires.

A line that is arcing results in line failure, which leads to power outages and loss of production, affecting the economy and human wellbeing.

HIFs cost utilities liabilities and service problems. In 2020, PG&E paid 23 billion dollars in fines for the 2018 California wildfire.

A. Overall fault coverage

Traditional overcurrent elements cover 90 percent of distribution faults, including some downed-wire events, as shown in Figure 3. However, some downed-wire events have a large impedance to ground and go undetected by traditional overcurrent protection (which is the portion in light green). For these high-impedance faults, modern relays employ high-impedance fault (HIF) detection to protect people and property.

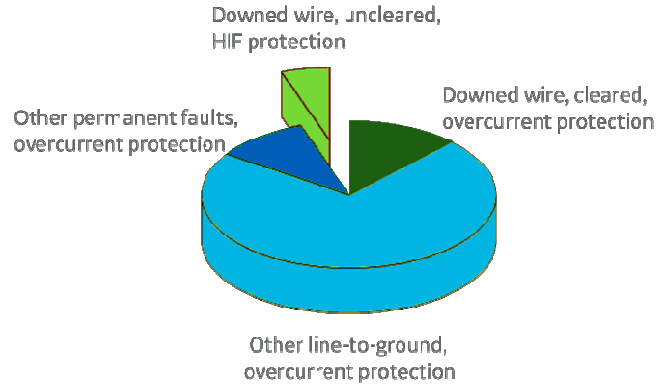

Fig. 3. Cleared and uncleared distribution-system faults

The goal is 100 percent detection of all HIFs, but it is impossible to detect *all* high-impedance faults. However, experience shows that 60–85 percent of HIFs are detectable. It is possible to achieve a large degree of dependability and security with a reasonably priced detection system.

If we assume 90 percent of faults are “low impedance” faults or overcurrent faults cleared by fuses and conventional overcurrent protection, and if the remaining 10 percent of the faults are high-impedance, downed conductors, then a modern microprocessor relay with instantaneous- and time-overcurrent protection, as well as HIF detection, can operate for 98% of the faults on a utility distribution system.

IV. EFFECTIVE HIF DETECTION TECHNIQUES

Modern HIF-detection techniques analyze arcing and load. Secure and dependable detection is required for high-impedance fault detectors. Early solutions, like an electromechanical relay that detected changes in 3I0 current, proved insecure, often causing nuisance trips.

Today, microprocessor relays with HIF detectors provide secure HIF detector performance under normal system conditions, such as noisy feeders, arc furnaces, arc welders, capacitor switching, line switching and load-tap changing. Modern HIF detection analyzes the arcing time-domain and frequency-domain components, measures increments in the current inputs (not absolute/peak values) and incorporates load analysis and pattern recognition.

There are two methods for detecting HIF using existing CT and PT inputs to protective relays. These methods work for solidly grounded, resistance-grounded, and Petersen-coil-

grounded systems. The two methods discussed in this paper are Method P and Method F.

Method P employs a zero-sequence core-balance CT (CBCT) as shown in Figure 4. It detects arcing faults by dividing the analog current input signal from the CBCT into an overall arcing-detection portion called Fundamental Analysis (FA), and into a third-/fifth-harmonics portion called Component Harmonic Analysis (CHA).

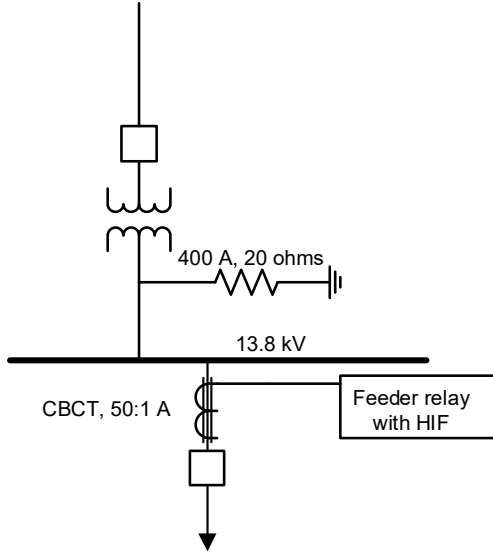

Fig. 4. Typical Method P installation, with CBCT

In addition, Method P uses voltage for a sensitive power calculation, to determine direction (DIR).

Method F employs a special analog-input module that amplifies each of the four inputs for three-phase currents and the residual-current inputs as shown in Figure 5. It is wired in series with the existing relay CT inputs. In addition, the Method F HIF processing uses voltage for phase identification and restraint. Method F learns the line noise and subtracts it from sensed arcing bursts.

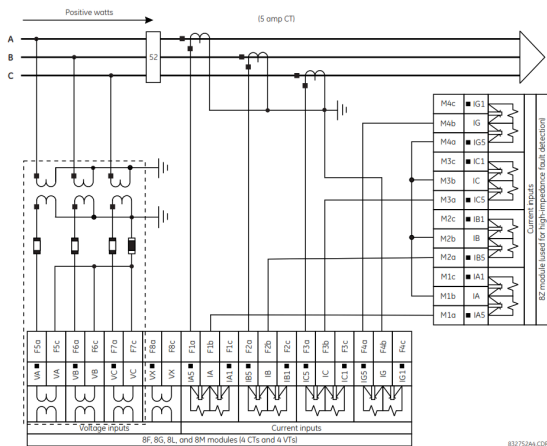

Fig. 5. Method F uses a Hi-Z processing module (M1a—M4c) wired in series with the regular relay current inputs

A. Method P details: FA, CHA, and DIR

Method P uses three components to provide a reliable HIF detection function:

- Fundamental analysis (FA)
- Component harmonic analysis (CHA)
- Directional analysis (DIR)

HIF detection relies on evaluating fault-current-waveform signatures. These waveforms differ from fault to fault (and within the same fault occurrence). However, there are common attributes in HIFs:

- Transient bursting (intermittent change of amplitude) on which the relay uses fundamental analysis (FA), with counters and timers
- Harmonic content (this method uses 3rd and 5th harmonics) on which the relay uses component harmonic analysis (CHA), detecting the periodic distortions at the zero crossings

To establish the fault direction, Method P uses an instantaneous power measurement in the directional-analysis (DIR) algorithm.

The overall block diagram for Method P (Figure 6) shows the voltage input V_N , and the sensitive-earth-fault current input I_{SEF} from the core-balance CT. Settings and reset are additional inputs to the HIF function. The two paths to the output are via fundamental analysis, FA, and component harmonic analysis, CHA. For each of the FA and CHA paths, the HIF outputs are transient (arcing detected) and HIF. In addition, the FA path outputs a Steady Fault operand. The main output is the ANDed combination of the FA HIF and the CHA HIF outputs, called HIF Alarm.

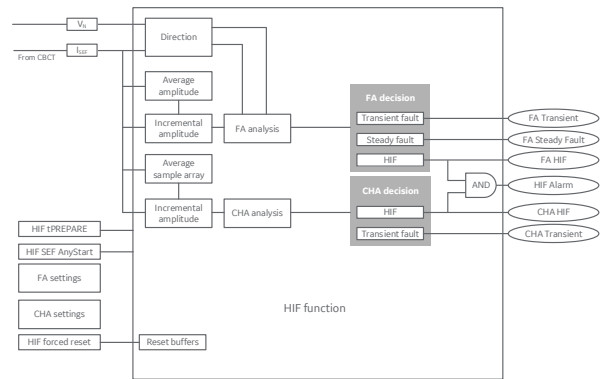

Fig. 6. Method P block diagram

1) Fundamental Analysis (FA)

Fundamental Analysis (FA) captures the intermittent characteristics of high-impedance fault current. Generally, the system current is stable and tracks the load conditions. Method P averages the sensitive-earth-fault current, summing the latest samples, and storing this value in a buffer. The relay compares this value continually with the latest current value. If there is a sudden increase in current, this value significantly exceeds the average value. It is this increment that starts the fault-evaluation process.

Once FA is triggered by any sudden increase of the amplitude, the algorithm counts bursts in a time window.

Only these sustained series of changes within the time window are evaluated as HIF. If the current-burst increment is greater than a start threshold, determined by the setting **FA> Start Thresh**, the FA algorithm evaluates the fault. The algorithm applies the Burst Valid (BV) threshold, determined by the setting **FA> Burst Thresh**, to judge whether the increment indicates fault-current conduction. By counting the changes of the BV states within a time window, the relay establishes that it has detected an intermittent fault.

An arcing fault triggers FA detection with any sudden, current-amplitude increase. However, the relay classifies only sustained series of changes within a specified time as a high-impedance fault (HIF). The following shows the classifications:

- HIF—bursts exceed set count within time limit
- Transient event—Bursts do not exceed count, but at least two bursts counted
- Steady event—Burst-count threshold exceeded
- Noise—other causes of detected current bursts (e.g., arc welding)

A declaration of HIF indicates certain confidence, and a steady event has very small arcing confidence.

These are the settings for fundamental analysis (FA) to adapt to specific applications:

- Burst-current threshold
- Burst count
- Monitoring time window

It is important to avoid nuisance alarms. Method-P FA uses these techniques:

- RMS measurements, not instantaneous values
- Measuring magnitude increments, not absolute values
- Adaptive monitoring time, following start

2) Component harmonic analysis (CHA)

Component harmonic analysis (CHA) measures the sensitive earth fault (SEF) current from the CBCT, compares this with the average current value, and uses the increment of the sampled value to extract the 3rd- and 5th-harmonic component. CHA evaluates the phase and amplitude differences between the fundamental and the third/fifth harmonics to determine the presence of HIFs.

The Satisfied State (SS) is the value that indicates HIF non-linearity; CHA measures the duration of the Satisfied State to evaluate and classify faults. The fault-evaluation process can be triggered internally or externally.

The criteria determining HIF non-linearities are the following:

- The fundamental amplitude is greater than a set threshold (setting **CHA> Fund Thresh**)
- The amplitude ratio between the 3rd/5th harmonics and the fundamental is greater than a set threshold (setting **CHA>3rdHarmThrsh**), and is greater than 90 percent of the fundamental

- The phase difference between the 3rd/5th harmonics and the fundamental is within a range of approximately 180° (settings **CHA Del Ang180-x** and **CHA Del Ang180+x**)
- These effects last for a significant time

CHA detects a fault by timing the duration of the Satisfied State (SS). If this time is longer than the HIF Setting time, an HIF event is reported. If the duration is shorter, but still longer than a Transient Setting time, the algorithm reports a CHA Transient event.

Similar to FA, a transient event needs further confirmation. The algorithm activates three separate timers once the CHA starts:

- A reset timer
- An HIF-duration timer measures the duration of this Satisfied State, to issue HIF
- A Transient timer detects any transient event

If the Satisfied State lasts for the entire time set by the HIF timer, an HIF is reported, and all procedures are reset. If the Satisfied State lasts for less than the HIF duration but is still more than the transient time, a Transient Suspicion event is reported and the detection process evaluates another section. If any HIF requirement is satisfied within the reset time, a HIF is reported, and the detection is reset. If there are more than three Transient Suspicion events reported within the reset time, a HIF is reported.

Flattening across the zero crossings indicates arcing. As the voltage wave passes through the zero crossing, the voltage available to drive the fault current reduces drastically, and therefore, the current waveform has ‘shoulders’ around the zero crossings.

Staged, downed-conductor testing shows that the CHA algorithm picks up for a conductor arcing in sand.

3) Directional Analysis (DIR)

Directional analysis helps with resistance-/impedance-grounded systems. The FA algorithm has no capability of detecting direction. FA-only is best used in a system with limited capacitance, or a system with a directly grounded neutral point. In these cases, the fault current on healthy lines is limited.

However, when a system is resistance-grounded, the fault-generated transient might be dispersed along both healthy and faulted lines because of large, distributed capacitances. Therefore, a directional element enhances FA performance for these systems.

The relay uses fault instantaneous power direction to obtain the transient direction, calculated directly from the fault-component (zero-sequence) samples. In transient situations, this is a more accurate method than using phasor-based power calculations. The fault component circuit is used for analysis. The source is the fault itself. The capacitive branch produces the reactive power while the inductance branch absorbs the reactive power. The resistance branch absorbs the active power, from the source. The reactive power from the source balances the total consumption of the reactive power by the other part of the circuit.

Generally, the reactive power is more distinctive, because the distributed capacitance is greater than the distributed conductance. Therefore, in resistance-grounded and in isolated systems, the reactive power direction is used for transient-direction detection. In Petersen-coil-grounded systems, the active-power direction detects the direction because the Petersen coil cancels reactive power flow.

The output of the direction detection function (DIR) are flags indicating the fault direction: FA DIR Forward and FA DIR Reverse. The relay sets these flags if the algorithm is in the Start stage and the criteria have been met. The FA function uses the flag status to determine whether it is a forward fault or a reverse fault. When counting a spike into the FA function's counter, the FA first refers to the direction flag. Only spikes with forward direction (Forward transient) are counted for fault evaluation. An alarm can also be set to indicate the faulted line.

4) Selecting the Method P solution

Select the HIF solution according to the system grounding, as shown in Table I. FA detects intermittent faults where the fault current is changing between conducting and non-conducting. This can be used in any system grounding conditions.

TABLE I. METHOD P SOLUTIONS

	Solid	Resistor	Petersen coil	Isolated
FA and DIR (active, P)	Yes	Yes	Recomm ended	Yes
FA and DIR (reactive, Q)	Yes	Recomm ended	No	Recom mended
FA (no DIR)	Recomm ended	No	No	No
CHA	Recomm ended	Recomm ended	No	No

CHA detects situations where there is a regular earth-fault harmonic. CHA should only be used for directly grounded and for low-resistance-grounded systems. As noted in this table, the directional element helps with Petersen coil and isolated systems.

B. Method P testing—field trials

Method P HIF detection field trials were performed on a 13.8-kV feeder, with a resistance-grounded source. A 50:1 core-balance CT fed the protection relay.

Figure 7 shows the waveforms recorded from downed-conductor tests. These waveforms show the erratic signature of arcing in rocky sand. Note the transition from FA Transient to FA HIF, marked in this graphic as “FA detects HIF.”

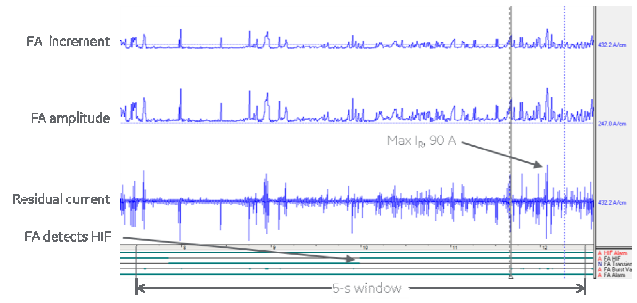

Fig. 7. Method P downed-conductor test result

Zoom in on the rocky-sand waveform, Figure 8 to view the FA increment increasing to yield “FA HIF” outputs.

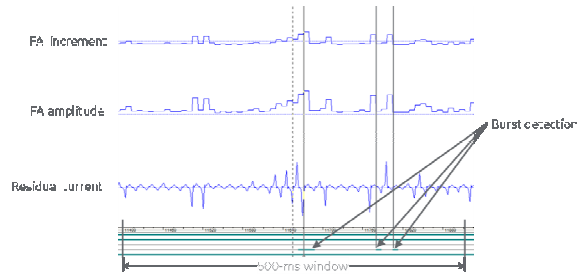

Fig. 8. FA HIF outputs

The component harmonic analysis (CHA) algorithm produces an HIF output for arcing in the rocky sand, as shown in Figure 9.

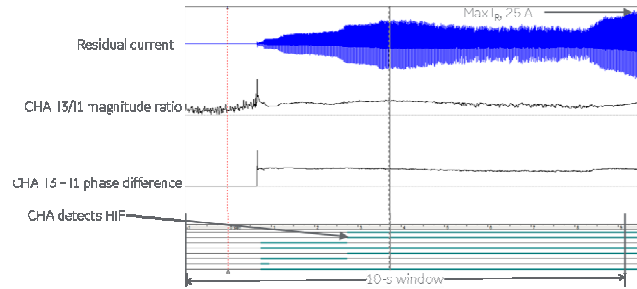

Fig. 9. CHA output on rocky sand

V. METHOD F: HARMONICS AND NON-HARMONICS; POWER-SYSTEM LEARNING; LOAD SUBTRACTION

Nine algorithms comprise Method F HIF detection. High-impedance fault detection is accomplished through a variety of techniques, all coordinated by an expert system. This HIF protection system monitors and learns the power-system nominal behavior. At the heart of the HIF detection system is identification of arcing on a feeder. If arcing is detected, the Expert Arc Detector determines whether the arcing persists for a significant period. If it does, it analyzes load current at the beginning of the arcing to determine whether persistent arcing is from a downed conductor or from an intact conductor. A collection of sensitivity and timing settings tune dependability and security.

If the HIF element determines that a downed conductor exists, oscillography and fault data are captured. In addition, target messages and appropriate LEDs are activated on the relay faceplate.

The detection of a downed conductor or arcing condition is accomplished through the following algorithms:

- Energy algorithm
- Randomness algorithm
- Expert Arc Detector
- Load Event Detector
- Load Analysis
- Load Extraction
- Arc Burst Pattern Analysis
- Spectral Analysis
- Arcing-Suspected Identifier
- Even Harmonic Restraint
- Voltage Supervision

The Method F block diagram in Figure 10 shows signal processing through the energy and randomness algorithms to the Expert Arc Detector. The relay processes phase and neutral current inputs for 60-Hz and odd-, even-, and non-harmonics. Voltage inputs have a confirmation check. The relay processes load extraction, arc-burst pattern, and spectral analysis. The results of these analyses proceed to the energy, randomness, and pattern-analysis algorithms. Next, the Expert Arc Detector decision structure provides separate HIF outputs for arcing detected alarm, arcing suspected, downed-conductor conditions, and fault identification.

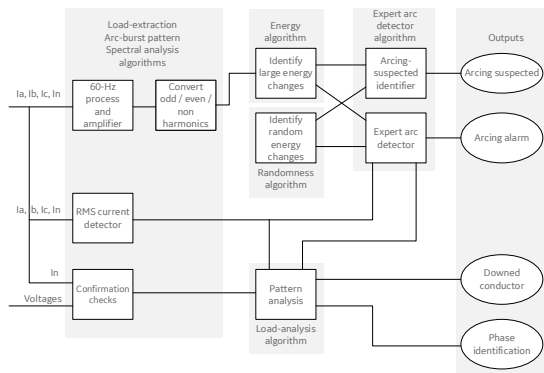

Fig. 10. Method F block diagram

Arcing causes bursts of energy to register throughout the frequency spectrum of the currents. These arcing bursts have distinct qualities and signatures; several of the HIF algorithms detect these patterns. The odd-, even-, and non-harmonic components of the phase and neutral currents are analyzed for these distinct patterns. The algorithms look for energy and randomness patterns. Separate outputs of the arc detection algorithms feed into the Expert Arc Detector.

A. Arcing Suspected output

In some cases, arcing is present, but not persistent. For example, when it is caused by tree limb contact or insulator degradation, arcing typically is present intermittently, interspersed with relatively long periods of inactivity (such as minutes). In these cases, arcing can be affected by such factors as the motion of a tree limb or the moisture and contamination on an insulator. Conditions such as these, characterized by a large number of brief occurrences of arcing over an extended period (for example from a fraction of an hour to one or two hours), lead the HIF element to recognize and flag an “arcing suspected” event. If an output contact is configured to indicate Arcing Suspected, the HIF element recognition of such sporadic arcing closes that contact and appropriate investigation can be taken.

B. Downed Conductor output

The basis for downed-conductor detection is event dependent. Differentiation between an arcing, intact conductor and an arcing, downed conductor is determined by looking at patterns in the load current at the beginning of the fault. User settings determine what constitutes a loss of load or an overcurrent condition. When a conductor breaks, generally there is a loss of load or an overcurrent condition when a phase hits another phase. This gives an indication that the conductor broke. The detection method looks for arcing to determine whether the conductor has fallen to the ground or hit a grounded object. A downed conductor is only when a loss of load or an overcurrent condition precedes arcing detection.

Avoiding nuisance outputs depends on many strategies. HIF detection monitors RMS currents, not instantaneous values that could false the HIF algorithms. The variable arcing-voltage causes a changing arcing-current shape, and thus, fluctuating harmonic content. Measured increments track bursts over time, not absolute values. This HIF method adapts to changing conditions and loads. Upon power-up, Method F learns the feeder ambient harmonic-energy level. It determines an ambient average noise level for the odd-, even-, and non-harmonic energy components of the currents each hour for three days. Then, it takes the worst average value over this three-day period and uses it as the harmonic noise threshold. The HIF algorithms ignore any harmonic energy patterns in the current below this ambient level. If the harmonic energy on the feeder changes, Method F re-determines a new ambient level to adapt to changing conditions. Another method for avoiding nuisance outputs is to use even-harmonic restraint and voltage supervision as final tests before declaring a downed conductor.

C. Arcing Alarm output

If there is only arcing and no loss of load or an overcurrent condition preceding the arcing detection, an Arcing Alarm is indicated (not a Downed Conductor output). It is assumed that the line is intact, with arcing present. This might be a bad insulator or a tree rubbing an intact conductor. If the detected arcing is persistent, and an output contact closes.

D. Method F testing—field trials

Many utilities have performed their own stage fault tests on both grounded and ungrounded distribution systems. Some utilities have performed “drop” tests, where a line is dropped intentionally to test the operation of the HIF detector.

Recent, in-field testing at PEPCO, where the Method F relay detected 82 percent of downed conductors. The study was based on 280 installed Method F, HIF relays on a distribution system of 620, 13-kV overhead feeders.

VI. METHOD COMPARISONS

Table II is a summary of the two methods for detecting and acting upon high-impedance faults. Shown are Method F and Method P.

TABLE II. SUMMARY OF METHOD F AND METHOD P

Feature / Method	Method F	Method P	Comments
Connection	Phase / residual	Zero-sequence CT / CBCT	
Difference (incremental) currents	Yes, 64 samples/cycle	Yes, 24 samples/cycle	Greater sampling rate catches fast transients
Spectrum monitor	Harmonics and non-harmonics to 780 Hz	3 rd and 5 th only	Process arcing frequency spectrum
Arcing-level reference	72 hours	Average recent samples	Ignore normal line noise and activity
Randomness algorithm	x	x	Quantify sudden, erratic changes
Counters, trending, and memory	x	x	Build certainty over time
Arc-burst pattern analysis	x	x	Identify faulted phase
Load-event detection	x		Block HIF for power-system events
Load learning and extraction	x		Remove normal load
Voltage supervision	x		Limit false alarms (adds security)
Directional analysis	logic	x	Isolates faulted line
Decision logic	Arcing suspected, Arcing alarm, Downed conductor	Transient suspicion, alarm— for FA and CHA	Provide action outputs

The methods share similar algorithms to detect high-impedance faults. These similarities center on sampling and tracking arcing bursts in the time and frequency domains. Both methods use an arcing-level reference, a randomness algorithm, and counters, trending, and memory to classify

high-impedance faults. The following is a discussion of the similarities and differences.

1) Difference incremental currents

The methods sample the current-amplitude differences. Thus, the methods track the fast changes in HIF bursts.

2) Arcing-level reference

Method F monitors the power-system phase and neutral currents to set a background level, as a reference for normal activity on the system. This period lasts 72 hours. A testing setting reduces the time to one hour.

Method P calculates a reference current by continually averaging the latest samples and stores this value in a buffer. It compares the averaged current with latest current value. If there is a sudden increase in current, its value exceeds the average value significantly, starting the fault-evaluation process.

3) Counters (employed for security)

The random on-off nature of HIF bursts means that the HIF protection methods cannot trip instantly. The methods employ counters to assure confidence that the burst is an arc or a downed conductor. Unlike traditional protection, HIF elements take 20 seconds and longer for an alarm / trip output.

4) Arc-burst pattern analysis

Method F inspects the incoming current bursts for randomness. HIFs display unsystematic timing and magnitude changes. Method F counts these random events in a time window, to build a confidence bias, toward declaring arcing and an HIF. Method P counts transients in time window; periodic events do not add to the count.

5) Directional analysis

There is no need to use directionality in a system with limited capacitance, or a system with directly grounded neutral point. In these cases, the fault current on healthy lines is limited. However, when there is arcing or a downed conductor, the healthy lines can carry the burst signal as well. This problem is prevalent in isolated, high-resistance-grounded, and Petersen-coil-grounded systems with a relatively large distributed capacitance; the fault-generated transient can be distributed along both the healthy and faulted lines. Therefore, a directional element can enhance HIF detection performance. Method P has a special directionality determination, to increase security for HIF outputs. Add directionality with logic to Method F.

6) Decision logic

Both methods employ outputs for specific HIF events.

a) Output for arcing: Transient (suspicion)/Arcing suspected

The methods have an output for transient events or arcing suspected. This output indicates that there are many brief arcing events over an extended period (for example, from a fraction of an hour to one or two hours). None of these brief occurrences of arcing indicate a downed conductor. When considered cumulatively, however, these arcing events need attention.

b) Output for high-impedance fault: HIF/Downed conductor

Once the burst sequence has passed all of the detection qualifications and the security algorithms, the HIF element

declares an HIF, or Downed conductor, event. At this point you must determine the action, to alarm, or to trip.

B. Differences between the two methods

Along with similarities, the two methods exhibit differences in detecting and acting for high-impedance faults.

1) Connections

A major difference is in the connection for monitoring HIF on the power system. Connections for Method F are to a high-sensitivity module (easily added to an existing relay) in series with existing phase inputs and summing through the residual input. It does not require special CTs in the substation yard. The Method P relay must be ordered with the HIF function, and it requires a core-balance CT, which can be difficult to retrofit into existing systems.

Sampling rate

Method F has the greatest sampling rate. This is an advantage for sensing fast, transient arcing. Also, data processing is faster.

2) Spectrum coverage (harmonics/non-harmonics)

Arcing HIFs produce a wide noise spectrum in the power system, both on harmonic multiples and between harmonics. The arcing energy between integer harmonics are called “non-harmonics.” Sensing and processing both harmonics and non-harmonics gives Method F more opportunity to detect HIF events.

3) Arcing-level reference

Method P averages a period of previous samples, whereas Method F learns a baseline for nominal power-system noise over a 72-hour period. Method F compensates for load events that mimic line arcing.

4) Load-event detection

Method F blocks operation (per-phase) for power-system changes, settings flags for each phase current and for the neutral based on the following events:

- An overcurrent condition
- A precipitous loss of load
- A high rate-of-change
- A significant three-phase event
- A breaker-open condition

These flags feed the load learning and extraction algorithm, increasing security.

5) Load learning and extraction

Method F uses load learning and extraction differentiates between arcing, downed conductors and arcing, intact conductors by looking for a precipitous loss of load and/or an overcurrent disturbance at the beginning of an arcing episode. This algorithm divides arcing into “arcing suspected” intact conductors and downed conductors, as well as reducing false positives.

6) Voltage supervision / even-harmonic restraint

This algorithm was implemented to minimize the probability of a false HIF indication due to bus voltage dips, for example, from parallel feeder faults. A fault on a parallel line can cause voltage dips that produce a decrease in the line

load that can be mistaken by the HIF element as Loss of Load.

Even-harmonic restraint inhibits setting the overcurrent flags. This is to prevent a cold-load-pickup event (lots of motor starting and transformer inrush) from starting the HIF logic sequence.

VII. IMPLEMENTATION STRATEGIES

When determining how to apply HIF detection for arcing and downed conductors, consider all the trade-offs involved. Unlike most forms of relay protection, downed-conductor protection is employed primarily for safety reasons; high-impedance faults rarely cause distribution equipment damage. In determining whether to employ HIF detection you should review the circuit to determine whether conventional protection is adequate. Apply HIF tripping / alarming depending upon experience with the soil conditions, type of circuit construction, experience with energized downed conductors, and the nature of the circuit load.

One popular application is sectionalizing the distribution system when an arc occurs. Upon detecting serious arcing or a downed conductor the closest recloser controller senses the arc and disconnects the line before a fire can start. This is a one-shot, trip and lockout sequence.

Recent power-line-caused wildfires in windy conditions shows that settings groups with faster response in windy weather are a good idea.

Consider alarming and tripping options for HIF events. It is not practical or advisable to trip the circuit quickly—some delay is appropriate for power continuity. However, tripping decreases the danger to human and animal life. It prevents wildfires and damage to property. In addition, tripping sooner limits legal liability and litigation.

Under non-wildfire conditions, consider alarming for arcing faults, and sending a crew immediately to investigate. Sectionalized tripping relieves the impact on supply continuity.

As stated previously, the small currents in arcing faults are a small risk of power-system asset damage. Depending upon experience with soil conditions and the line build out you can evaluate the likelihood of unwanted trips. Replace fuses with HIF-detection-equipped relays to manage distribution arcing protection, especially at the ends of lines.

VIII. CONCLUSIONS

Special techniques are required to detect high-impedance faults (HIF). HIF methods identify significant percent of Hi-Z faults, modern methods at 80 to 85 percent. HIF protection prevents fires and increases safety. Testing and experience improves application effectiveness.

This paper presents two methods, Method P and Method F.

Common to these methods are the following:

- Arcing sense and level settings to adjust to your power-system conditions
- Counts and other security measures to identify arcing faults and broken conductors accurately

- There are outputs for arcing suspected and downed conductor, so that you can take appropriate mitigation actions

Differences in the two methods are the following:

- Connections—Method P is via a core-balance CT, and Method F has a module in series with the phase-current and residual current inputs. (Both can use voltage.)
- Spectrum/harmonics—Method F looks at more of the spectrum
- Load subtraction is a function in Method F that makes it secure against regular feeder noise events

Applying HIF protection takes some finesse. Testing and experience improves application effectiveness.

IX. REFERENCES

B.M. Aucoin, R.H. Jones, "High Impedance Fault Implementation Issues," IEEE Transactions on Power Delivery, January 1996, Volume 11, Number 1, pp 139–148

B. D. Russell, B. M. Aucoin, T. J. Talley, "Detection of Arcing Faults on Distribution Feeders," Texas A&M University, EPRI Final Report EL-2767, December 1982

W. Tyska, B. D. Russell, B. M. Aucoin, "A Microprocessor-Based Digital Feeder Monitor with High Impedance Fault Detection," 47th Annual Texas A&M Relay Conference, March 21-23, 1994

"High Impedance Fault Detection Technology Report of PSRC Working Group D15," March 1, 1996, https://www.pes-psrc.org/kb/published/reports/High_Impedance_Fault_Detection_Technology.pdf

CIGRE Working Group B5.94, "High Impedance Faults," December 2009

General Electric MiCOM, "P40 Agile P14D Instruction Manual," Publication Reference P14D-TM-EN-8

S. Subramanian, K. Venkataraman, Detection of High Impedance Faults in MV Distribution Systems, 11th International Conference on Developments in Power System Protection, April 2012

Wester, C., "High Impedance Fault Detection on Distribution Systems," GER-3993, General Electric,