

Integrated Power Management and Protection System for a Remotely Located Islanded Facility

Mehul Joshi and Greg Smith, *Teck Resources Limited*

Pradeep Varma Sangaraju, Ashish Upreti, and Maaz Kazmi, *Schweitzer Engineering Laboratories, Inc.*

Abstract—In the modern world, ensuring power system reliability and management is imperative for safety of human lives and to minimize production interruption. This is especially paramount for a facility such as Red Dog mine, which is situated above the Arctic Circle in Alaska, USA, with no available utility connection. This paper describes the design philosophy, system architecture, implemented solutions, and testing methodologies used for the power management system (PMS) provided for Red Dog. The entire electricity at the mine is supported by eight onsite generators, 5.5 MW each, distributed among three buses. Two of these buses are connected using a current limiting reactor. The primary loads are personnel accommodation, ball mills, sag mills, stir mills, pumps, compressors, conveyors, and some variable-frequency drive (VFD) loads that have active front end (AFE) providing reactive power support.

The solution includes high-speed load-shedding, automatic generation control for frequency management, unique reactor control for limiting current (amperes), and VFD control for voltage stability, reactive load-sharing, and automatic synchronization of different electrical islands. The high-speed load-shedding system includes three algorithms that are contingency, underfrequency (UF), and overload-based schemes.

This paper also discusses control hardware-in-the-loop (cHIL) testing using a real-time transient-level computer model of the power system. This was used for functional testing of the PMS including protection and automation prior to field deployment.

I. INTRODUCTION

Red Dog, owned and operated by Teck Resources Limited, is an open pit zinc and lead mine, located about 170 kilometers (106 miles) north of the Arctic Circle in northwestern Alaska, USA. It has the world's largest zinc reserves and accounts for ten percent of the world's zinc production. Once the ore is processed, the lead and zinc concentrates are transported via a 84-kilometer (52-mile) road to a port facility on the Chukchi

Sea, which can only operate in the summer months due to the harsh winters.

Since Red Dog is a remote location with no connection to the grid, it is important to have an advanced power management system (PMS) that can not only protect the frequency and voltage stability under regular conditions but also prevent blackouts by taking high-speed load-shedding actions, when required.

The electrical power requirement at the mine is met by eight onsite generators, each one rated at 5.5 MW and fed into three different buses. The eight diesel generators are split on either side of a current limiting reactor, and all the loads are distributed between these three buses as illustrated in the simplified one-line diagram (see Fig. 1).

II. POWER MANAGEMENT SYSTEM (PMS) OVERVIEW

PMSs are being installed in a wide range of applications ranging from microgrids, universities and various industrial facilities, to country wide macro-grid schemes [1]. The primary goal of any PMS is to maintain the frequency and voltage stability of the power system. The PMS achieves this goal reliably using intelligent algorithms that run in the generation control system (GCS) and load-shedding processor (LSP) controllers. While the GCS maintains the frequency and voltage by dispatching set points to the governor and exciter, the LSP performs high-speed load shedding in response to a loss of generation and quickly restores the load-generation balance to achieve system stability [2]. These real-time automation controllers (RTACs) run continuously at subcycle speeds, constantly monitoring data and taking vital requisite actions as necessary. The following section will discuss in detail the communication architecture governing these systems.

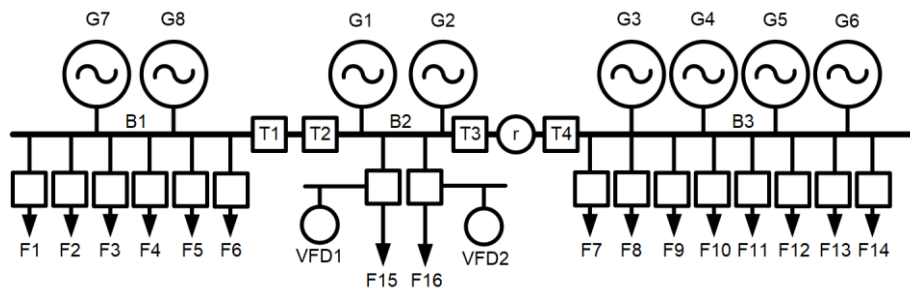

Fig. 1. Simplified electrical one-line diagram from Red Dog mine

III. COMMUNICATIONS OVERVIEW

The controllers make load shedding and generation control decisions based on data they receive from relays in the field. The relays typically transmit high-speed data via protocols such as IEC 61850 GOOSE or MIRRORING BITS[®] communications while slow-speed data are transmitted via IEC 61850 MMS, Modbus or DNP3 protocols. The judicious application of protocols is key to ensuring both power system stability and management of network burden [3].

At Red Dog the data from all the relays in the field are sent to two redundant data concentrators (A and B). The relays send the high-speed data via IEC 61850 GOOSE protocol; whereas, the slow-speed data are transmitted via IEC 61850 MMS protocol. The data concentrators (A and B) then communicate with the LSP and GCS controllers via NGVL protocol. The controllers provide a visual indication to the human-machine interface (HMI) by first transmitting to the Gateway (GW) via NGVL protocol, and the GW acts as a protocol converter by passing tags to the HMI via DNP3 protocol. Fig. 2 illustrates this communication.

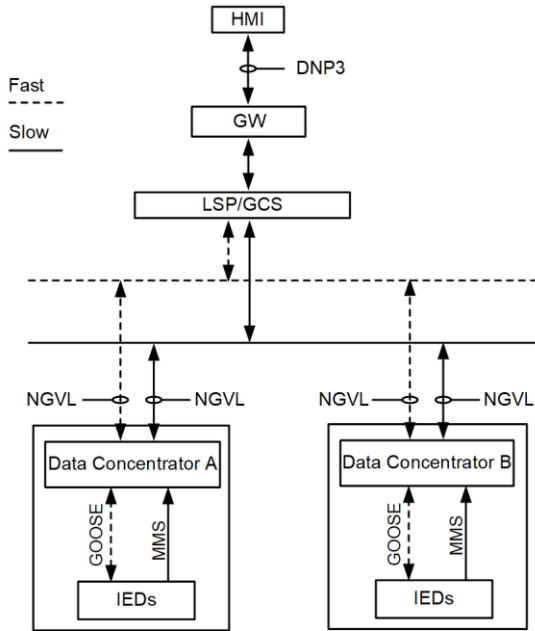

Fig. 2. Communication architecture

IV. LOAD-SHEDDING PROCESSOR (LSP)

Load shedding systems come in different configurations, depending on the requirements of the power system application, but the common goal is to preserve the stability of the power system by performing high-speed load-generation rebalancing. The LSP does this effectively via three algorithms that run concurrently and use different inputs as contingency triggers for load shedding. These algorithms are discussed in the following section.

A. Contingency-Based Load Shedding (CLS)

The CLS defines a contingency as the opening of a breaker that causes a power deficit in the system. For example, generator breakers would classify as contingency breakers. The LSP is constantly monitoring the system, and when it detects this contingency, it intelligently sheds load (priority-wise) on the same electrical island where the deficit occurred within milliseconds to maintain the load-generation balance. The typical round-trip time, excluding the breaker operation, is expected to be between 30 and 50 milliseconds. To enable such high-speed shedding, the controller constantly tracks the system topology and arms itself ahead of the actual event. By shedding load according to available capacity, the system can minimize the negative effects of frequency in the system, thereby restoring the power balance. There are 13 contingencies that have been identified for the CLS in this project and are listed in Table I. Typically a load feeder does not constitute a contingency, but F9 is set up as a contingency here since it can act as a power source when required, via an emergency generator.

TABLE I
LIST OF CLS CONTINGENCIES

Contingency	Asset
1	G1
2	G2
3	G3
4	G4
5	G5
6	G6
7	G7
8	G8
9	T1
10	T2
11	T3
12	T4
13	F9

B. Underfrequency-Based Load Shedding (UFLS)

This scheme sheds load based on underfrequency (UF) triggers from protection relays by detecting frequency decay in the system. Despite the contingency-based scheme, a frequency decay could still occur due to the opening of an alarmed breaker, load-shedding failure due to wiring/trip coil issues, and incorrect load metering values. When this happens, the UFLS sheds load and helps recover the system frequency.

The different UF thresholds selected for this project are indicated in the frequency line diagram in Fig. 3.

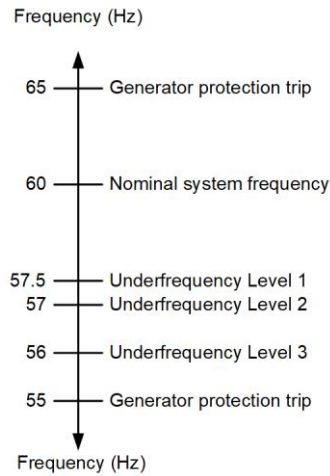

Fig. 3. Frequency line diagram

Once the controller sheds load based on the Level 1 trigger, the system frequency is expected to recover, but if it does not recover and Level 2 UF is subsequently triggered, additional load is shed based on the set point for that level. Table II lists the UF contingencies that identify the buses where the UF level triggers are monitored for this project.

TABLE II
LIST OF UFLS CONTINGENCIES

Contingency	Bus
1	B1
2	B2
3	B3

A voting scheme is set up to process the raw UF triggers from the field. The controller looks at all the relays on the island and only responds to a UF contingency if there are at least two relays from that island that have detected a UF trigger. This ensures that the controller does not inadvertently act on one trigger that could have been generated due to incorrect settings on that relay, wiring issues, mapping errors, and more.

The amount of load to shed for a UFLS contingency is calculated as a percentage of the total load and is done for every island independently. Using percentages instead of fixed real power values allows for scalability between differently sized islands and is critical for a remote power system that could have different island configurations. The percentages in Table III are operator settable through the HMI and are recommended based on closed loop testing in the laboratory.

TABLE III
UF SHED TABLE

Level 1	Level 2	Required to Shed
10%	10%	X % of total system load on that island

For Level 3, instead of further shedding any load, a bus separation scheme is implemented, where the bus couplers associated with the UF contingency are opened, and the rest of the electrical system is isolated from the affected buses.

C. Progressive-Based Load Shedding (PLS)

This scheme sheds load based on monitoring the output power values of a source, such as a generator or a utility tie line, and once the output exceeds the threshold for an operator defined time, the controller sheds load to bring the power values within the threshold [4]. This scheme is based on an integration function that is akin to an inverse overprotection curve with time-to-shed load that is inversely proportional to the overload. The greater the overload, the less time it takes to shed load, and vice versa.

For this remote facility, along with monitoring the instantaneous overload, an hourly rolling average overload scheme was provided. The controller captures snapshots of the real-time power values every minute and calculates the average for the last 60 values. This scheme is set up to meet EPA requirements, which mandates a limit on the hourly average output of the generators. Once load shedding occurs, the contingency locks out for a predefined time with an automatic reset after the load-shedding action. If the assets continue to be overloaded after the lockout time, the controller will perform load shedding again until the asset is under the threshold.

D. Overall Load Selection and Processing

The controller is programmed with a list of sheddable loads that are provided by the mine. Several factors such as load priority, present power, breaker status, binary/analog alarm, etc. go into the selection of a sheddable load for a contingency. The flowchart in Fig. 4 illustrates the way the controller goes through every load until it has selected enough load to satisfy the required shed demand for every contingency [5].

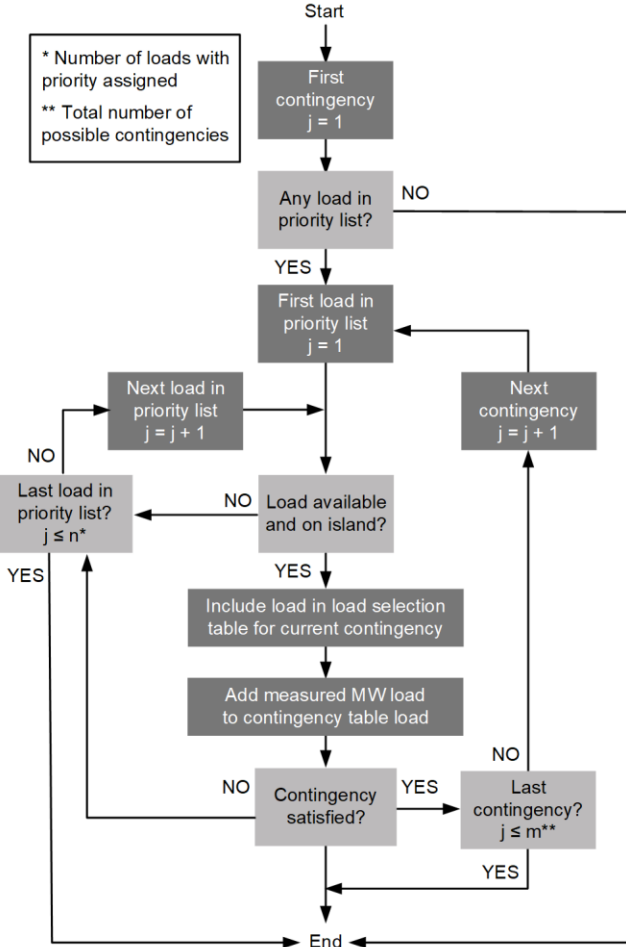

Fig. 4. Load selection flowchart

1) Multiple Priority Lists

Typically, load shedding controllers select loads to shed based on a priority list. The loads are sorted dynamically based on operator changes to that priority list, and then the controller selects loads based on priority that are on the same electrical island as that contingency.

For this mine, however, two separate priority lists (Group A and Group B) were developed to accommodate the unique requirement of minimizing the current flow across the reactor, post load-shedding. For all CLS and PLS contingencies on the left side of the reactor, the Group A priority list is used. For all CLS and PLS contingencies on the right side of the reactor, Group B priority is used. For UFLS contingencies, which are not tied to any particular asset but the overall system frequency, there is a third priority list, which is derived from the two priority lists (A and B). The priorities are derived in this

manner: Priority 1 from Group A is assigned Priority 1, Priority 1 from Group B is assigned Priority 2; and Priority 2 from Group A is assigned Priority 3, and Priority 2 from Group B is assigned Priority 4. This continues, until all loads are assigned priorities. This ensures that the third priority list for UFLS picks equally from the two priority lists (A and B). This also confirms that loads from both sides of the reactor are selected for a UF event.

2) Sheddable Load Feeding Another Sheddable Load

In this system, there were some cases when one sheddable upstream load was feeding into another sheddable load downstream. In those cases, special calculations regarding power flow and priorities are implemented in the algorithm for the upstream loads. Consider the example in Fig. 5.

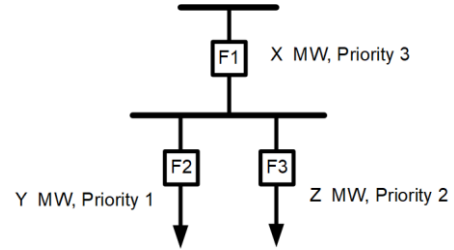

Fig. 5. Sheddable load feeding another sheddable load

Feeder 2 (Priority 1) and Feeder 3 (Priority 2) each consume Y and Z MWs, whereas, Feeder 1 (Priority 3) feeds both of these loads and is metering X MW. When the load selection algorithm traverses through the priority lists and selects F1 after F2 and F3, it results in an incorrect calculation, since the real time metering value of F1 will already include F2 and F3 values. Hence, the power of F1 is modified to subtract the power of downstream loads (F2 and F3). This real power modification ensures system stability.

Similarly, when priorities are concerned, if an upstream load has a higher priority than a downstream load, it will be inhibited. This is to ensure that the controller first selects and trips the downstream loads before going upstream. This means that if the priority of F1 was set to 1, then the controller would automatically inhibit that load for selection; at this point, the operator can change the priority to a number that is greater than the priorities of the downstream loads (greater than 2).

V. GENERATION CONTROL SYSTEM (GCS)

In an islanded facility, a GCS provides flexibility of operation and control of different power system parameters, such as frequency, voltage, active power, reactive power, and current flow across reactor. It also participates in system synchronization by controlling the governor and exciter of synchronizing island generators. There are different components in a GCS as discussed in the following section.

A. Automatic Generation Control (AGC)

The AGC dispatches set points to the governor for percentage load sharing while simultaneously controlling the system frequency (F) and limiting ampere (I) flow across reactor breaker.

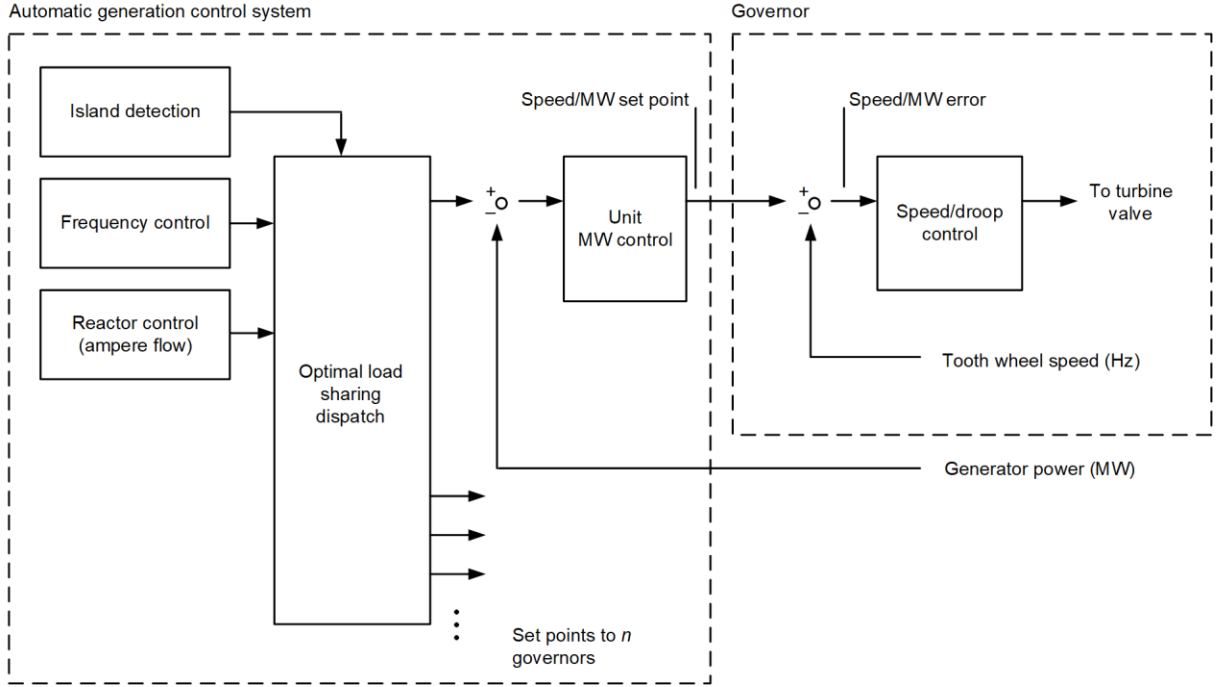

Fig. 6. Typical AGC control strategy

The typical AGC algorithm is presented in Fig. 6. The AGC sends a MW set point to the governors of running turbine generators. The set point for each generator is determined by the optimal load-sharing controller that receives biased commands from the frequency control loop. The required percent deviation from nominal is calculated using (1):

$$\% \text{Deviation} = \frac{\text{System_Load} - \sum_{i=1}^n \text{MWBaseSP}_{\text{GEN}_i}}{\text{Total_Capacity} - \sum_{i=1}^n \text{MWBaseSP}_{\text{GEN}_i}} \quad (1)$$

where:

- System_Load is the total present output of all generators (MW); this equals the plant load.
- Total capacity, as shown in (2) is equal to the summation of all the generator capacity, where the generator capacity is the least of the following three factors:
 - Operator-entered upper-regulation limit
 - Generator capability curve
 - Turbine capability

$$\text{Total_Capacity} = \sum_{i=1}^n \text{Generator_Capacity} \quad (2)$$

Equation (3) calculates the difference of the individual generator capacity and MW base set point multiplied by the percent deviation to give the individual generator deviation (in MW).

$$\text{Deviation}_{\text{GEN}_i} = \% \text{Deviation} \cdot (\text{Generator_Capacity}_{\text{GEN}_i} - \text{MWBaseSP}_{\text{GEN}_i}) \quad (3)$$

Equation (4) calculates the new power request for the AGC unit dispatch.

$$\text{Power_Request}_{\text{GEN}_i} = \text{MWBaseSP}_{\text{GEN}_i} + \text{Deviation}_{\text{GEN}_i} \quad (4)$$

In addition, if the ampere flow across the identified reactor breaker reaches the overload threshold, AGC demands the generators of the bus that is importing power to increase the output to the upper regulation limit until the current flow drops below 80 percent of the threshold and simultaneously manages frequency and load sharing among the generators on each side of the reactor, as shown in Fig. 6.

B. Voltage Control System (VCS)

The VCS dispatches generator exciter set points for percentage reactive load sharing while efficiently utilizing the active front end (AFE) drives and generator excitation to maintain the system voltage. The algorithm is designed to utilize the AFE drives for maximum VAR support to achieve better power factor and a stable reserve margin for the generators. Simultaneously, VCS also manages reactive power flow across the reactor breaker and monitors the generator terminal voltages to stay within acceptable limits. The VCS is also integrated into the automatic synchronization system (AS). Fig. 7 shows the overall strategy of the VCS.

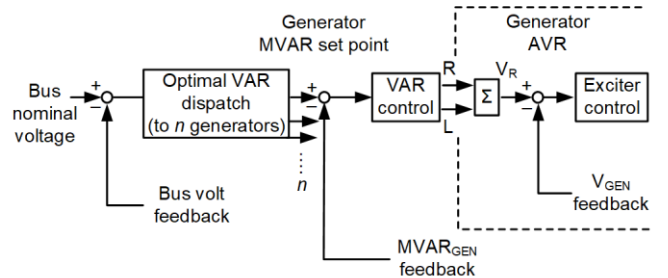

Fig. 7. Typical VCS control strategy

C. Islanding Control System (ICS)

The ICS tracks the number of islands in the system and monitors the generators and variable-frequency drives (VFDs)

connected to those islands. Accordingly, the ICS creates the individual AGC and VCS control loops for each island formed and assigns the modes of governor and exciter as required in those islands. In Red Dog, there is no utility connection, and the GCS controls the governors in Droop mode and exciters in Voltage mode.

D. Generator Capability Tracking System

An intelligent GCS is equipped with a generator capability tracking algorithm that uses a least-value method to determine the allowable operational region for the AGC and VCS. The controllers dispatch the generator within user-defined regulation limits of the machine. This region is used to calculate the MW and MVAR spinning reserves for each unit. Fig. 8 represents generic capability curves and shows different operating scenarios within the allowable operational region (shaded area). Fig. 8 (top) shows an example in which the user-entered regulation limits are within the capability curve and the turbine limit; however, they are outside the turbine limit for Fig. 8 (bottom).

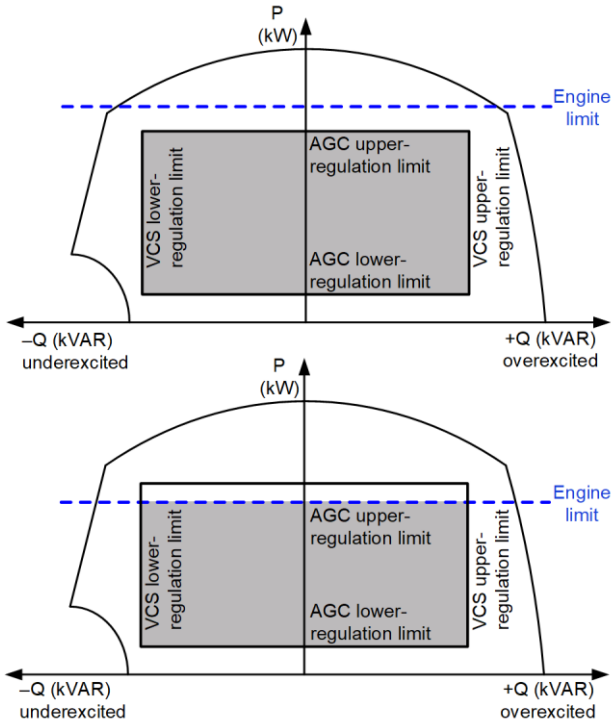

Fig. 8. Generator capability – regulation limits with generator boundary

E. AS System

An AS system is required to synchronize generators and different electrical islands across bus ties and to synchronize with emergency generators. Unit synchronization systems synchronize individual generators to power grids, while island synchronization systems synchronize and reconnect different power system islands. These systems are required to function automatically with minimal human supervision, because they must dispatch multiple generators simultaneously to reduce slip and voltage differences at the interconnection point. Once the sync is initiated, the AS system performs safe, secure,

unattended synchronization control of islanded power systems [6].

The AS system algorithm is presented in Fig. 9; the slip and voltage difference measurement from the AS IED is fed to the GCS. The GCS dispatches governors and exciters to bring the frequency and voltage differences within breaker closing limits. The AS IED automatically closes the breaker once the phase angle is within the defined band.

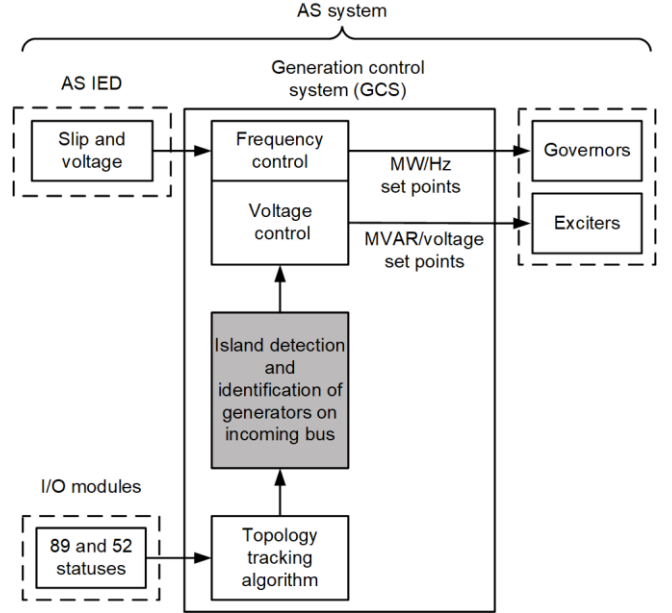

Fig. 9. Auto synchronization control system

VI. SIMULATION SYSTEM

A. Real-Time Digital Simulator (RTDS)

The authors of this paper designed and developed a state-of-the-art simulation system with a model specific to Red Dog. The simulator is capable of continuous real-time operation using a hardware-based electromagnetic transients program (EMTP). The simulator was connected to panels in the closed loop with PMS equipment, protective relays, governors, and exciters, all communicating via hardwired connections and project specific protocols. This simulator ran power system scenarios in real time, and data from these scenarios were fed into the closed-loop control system for validation. This also helped with training operators who were present during a factory acceptance test (FAT) [7]. The following section provides an understanding of how different components of the power system (generators, excitation systems, governors, transformers, loads, etc.) are modeled and validated for Red Dog.

B. Generator Validation

Step tests were performed to study the response of the exciter and governor models on a per-generator basis. For this validation, a test system was developed consisting of a generator connected to an infinite bus and two loads through a step-up transformer. Each of the components could be isolated by operating the breaker connected to the generator bus. This validation allowed the authors to see the effects of the

prescribed gains and time constants of the excitation and turbine governor system with the given generator. These tests included load acceptance, load rejection, and governor step response for the governor. For the exciter, the test included an exciter step response and Full Speed No Load (FSNL) test. Fig. 10 shows the frequency response of the generator unit's response for the step load acceptance test.

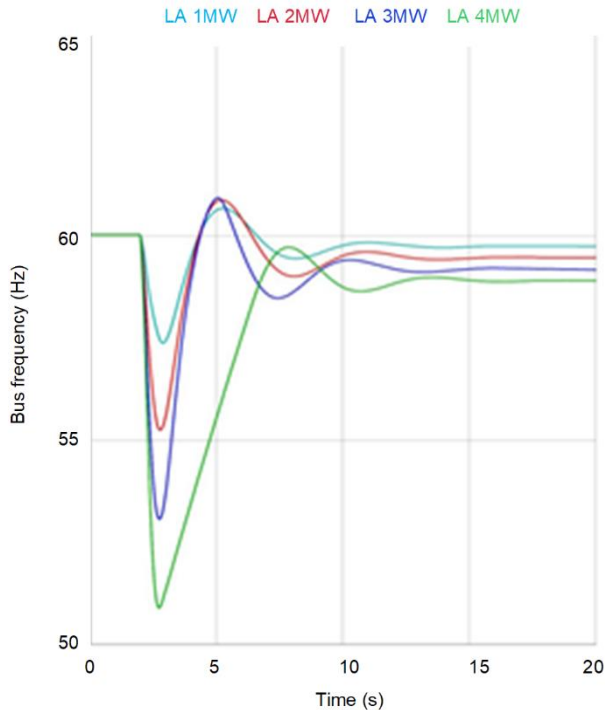

Fig. 10. Combined load acceptance test for 5 percent loading

1) Load Modeling Validation

Two types of load modeling are done for the Red Dog mine system: loads at 4.16 kV and 480 V. All substations containing sheddable loads with mitigation devices are modeled as sheddable loads, where the PMS could individually shed loads; whereas, in the substations where no mitigation devices are present, the loads are modeled as nonsheddable lumped. The detail model includes induction machines, synchronous machines, and drives that are unique to Red Dog. The VFDs had an AFE which could control the reactive power output to aid in system voltage regulation. Since load modeling accuracy

is required for system fault behavior and coordination, a detailed model was developed [8].

2) Drive Modeling and Validation

After receiving data from the manufacturer, the drive configuration is modeled as a three-level back-to-back voltage source converter (VSC), which results in a four-level stepping waveform, compared to an eight-level stepping waveform in the field. The control modules, such as current, speed, dc voltage, and voltage suppression control are all like the field model. The gains are scaled to the equivalent model but are tuned to provide the same response as the actual drive system. This drive model is then validated with the field model until the system response is deemed close for testing with the PMS functionality.

The simulation includes modeling protective tripping to understand the interaction of PMS with existing protection system. One relay of each type between generator protection, feeder protection, and bus protection was set up to test the protection logic, including the AS and bus separation relays. A system preservation scheme was developed in conjunction with PMS to improve resiliency of the mine operations. Initially, relays on the main feeder were coordinated with the next downstream device utilizing industry standard overcurrent coordination philosophies [9]. However, when the relay phase and ground instantaneous overcurrent set points were calculated and simulated using RTDS, it was deemed insufficient to isolate fault equipment within critical clearing times. This resulted in a preservation scheme for closed-in faults where a higher instantaneous element was utilized, which de-energized the bus where the fault occurred [10].

3) Dynamic Performance Validation

The governor and AVR models developed in RTDS were tested against hardware units for complete validation and tuning prior to field commissioning. The test setup, as shown in Fig. 11, allowed the control of generators with governors and AVR either in hardware mode or software mode within the model. Once the dynamic validation was completed, field settings for the governors and exciters were finalized [10]. Typically, governors and exciters are not included as part of control hardware-in-the-loop (cHIL) testing; however, for this critical islanded mine, it was important to test upgraded governor and exciter units with tested settings and validate the performance before interacting with PMS.

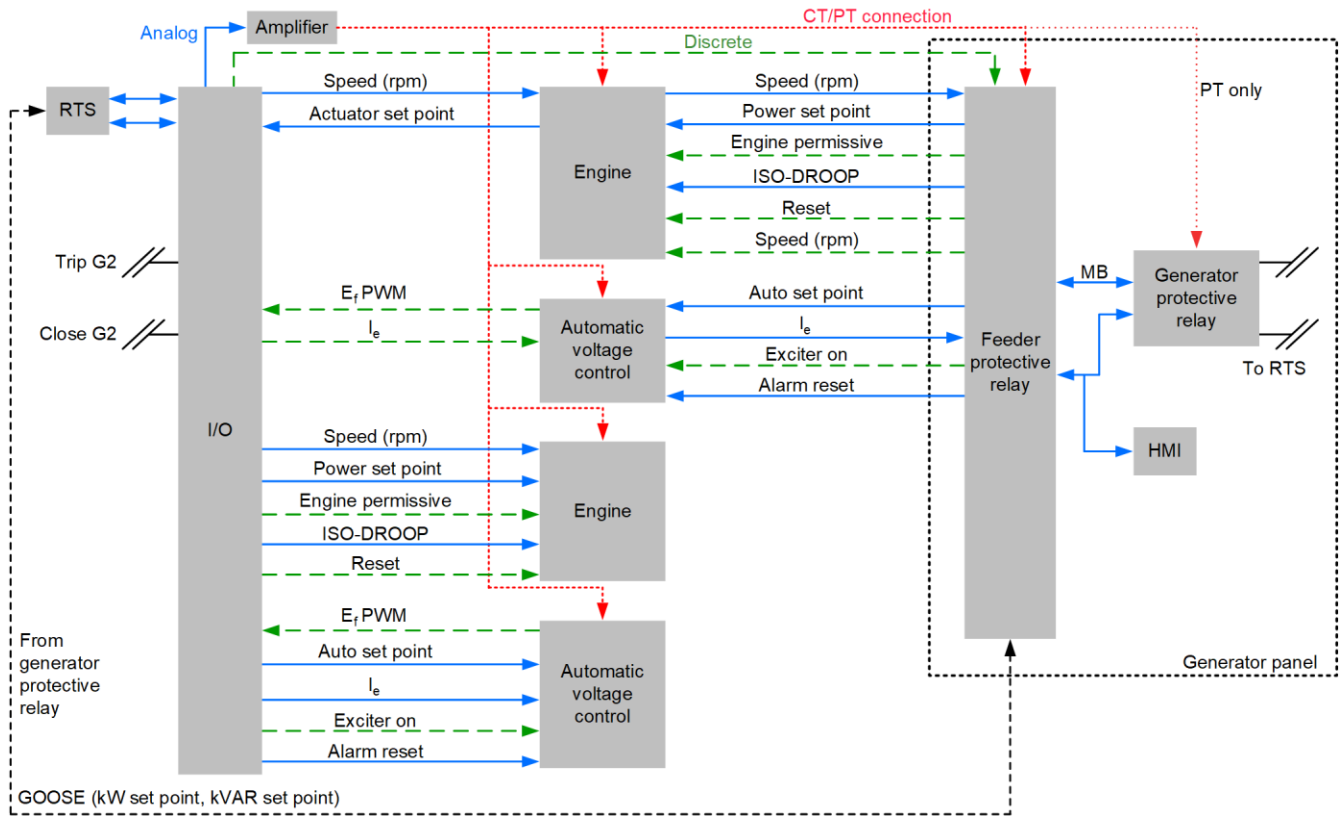

Fig. 11. Governor and exciter interface

VII. DYNAMIC TESTING AND ANALYSIS

Prior to installation of the PMS, a complete FAT was performed in a laboratory. Several studies were done using the model, providing insight into plant operations, vulnerabilities, and system responses for many contingency events, including corner cases. Studies also determined optimal set points for PMS. As shown in Fig. 12, this was accomplished by connecting the PMS to the simulation hardware.

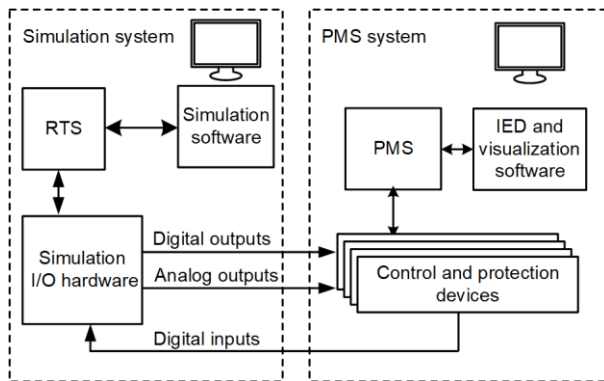

Fig. 12. System simulation setup

A. Case 1: Generator 1 Trip Contingency

The primary objective of this case was to demonstrate the operation and coordination between different components of the PMS, such as CLS, UFLS, PLS, and GCS. Generator 1 was tripped, while all six engines were running. Generator 1 was running at 4.955 MW. The total system Incremental Reserve Margin (IRM) was 2.5 MW (0.5 MW for each of the generators on the island, excluding Generator 1). The CLS calculated the Required to Shed (RTS) as 2.45 MW and Selected to Shed (STS) as 4.25 MW. The STS was greater than RTS because the next available load based on the priority was much larger. Once the contingency was triggered, the CLS shed the calculated loads. The frequency dipped to 59.5 Hz and recovered to nominal frequency after load-shedding.

This event demonstrated the mine's capability of surviving the loss of a generator during the peak loading scenario. The selected IRM value was sufficient, so no further frequency- or overload-based load shedding was necessary.

In Fig. 13, the active and reactive power of Generator 1 dropped to zero around two seconds, and the other generators slightly picked up the load. Fig. 14 shows the system voltage and frequency when the frequency initially dipped to 59.5 Hz but later recovered to nominal. There was also small voltage disturbance during this event which quickly recovered to a steady state nominal value.

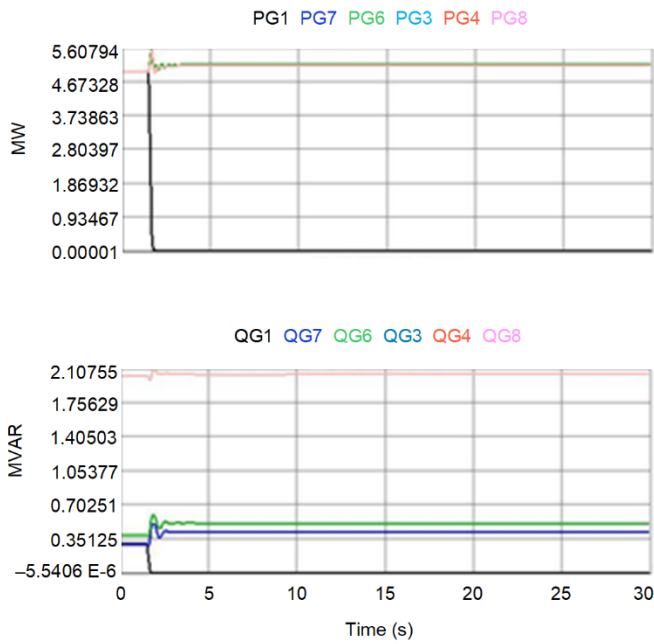

Fig. 13. Case 1: Generator active and reactive power

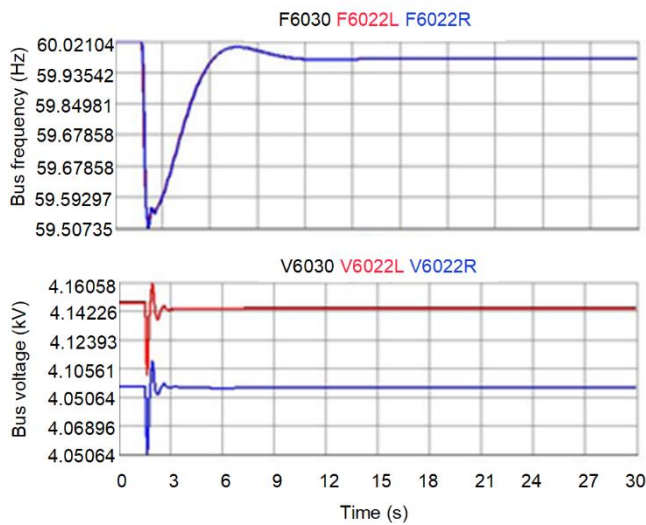

Fig. 14. Case 1: System voltage and frequency

B. Case 2: UF Event (CLS Disabled)

The goal of this test was to validate the frequency-based load shedding at Red Dog mine. The CLS system was disabled and the system response during a UF event was evaluated. The system initial conditions were setup up so that all six generators were operating at 4.9 MW. One generator was tripped, and system loading was approximately 29.6 MW. Since the CLS was disabled, the frequency continued to decay until UF Level 1 triggered. The calculated RTS was 2.765 MW. Based on the available load and priority setup, it resulted in shedding a total load of 4.245 MW. Fig. 15 shows the frequency and voltage response of the system during this event. The frequency dipped to 56.86 Hz before recovering close to nominal after load shedding. The decay in the system frequency before load shedding shows the effect of load characteristics and governor response on the power system.

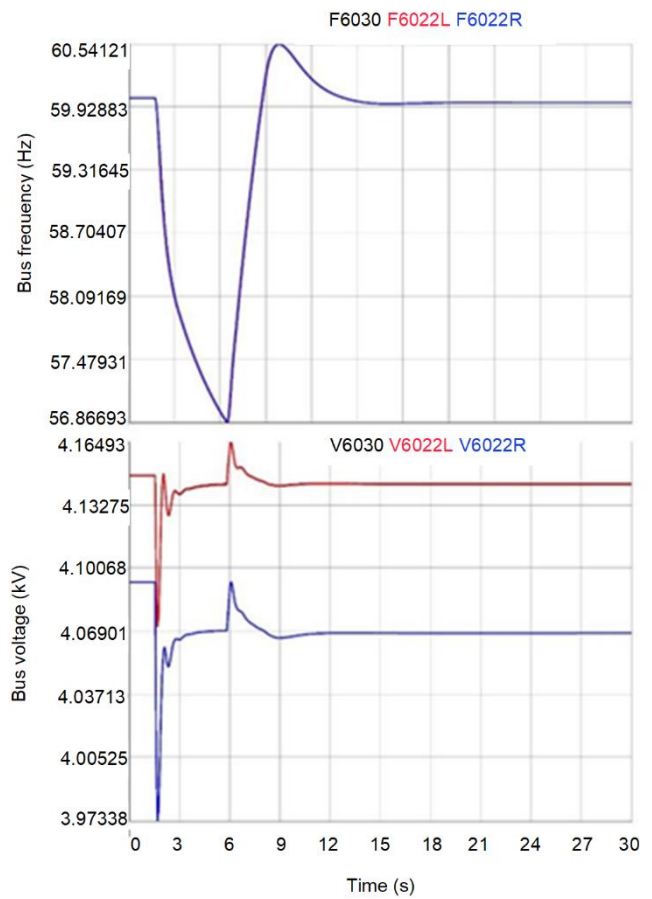

Fig. 15. Case 2: System frequency and voltage

C. Case 3: Two Simultaneous Island Events (CLS Disabled)

The goal of this test was to demonstrate how load selection is based on islanding by splitting the system into two islands. Buses B1 and B2 are part of one island (Island A), while Bus B3 is on the other island (Island B). Bus Tie T3 was opened with 2.8 MW flowing from B2 to B3. This loss of import on Island B caused the system frequency to decay; this was detected by UF trigger detection relay on the island. Two valid triggers initiated a UFL1 trigger. The RTS was 1.2 MW and STS was approximately 2 MW. Fig. 16 shows the decay in frequency in Island B and rise in frequency in Island A. After load shedding, both islands survived.

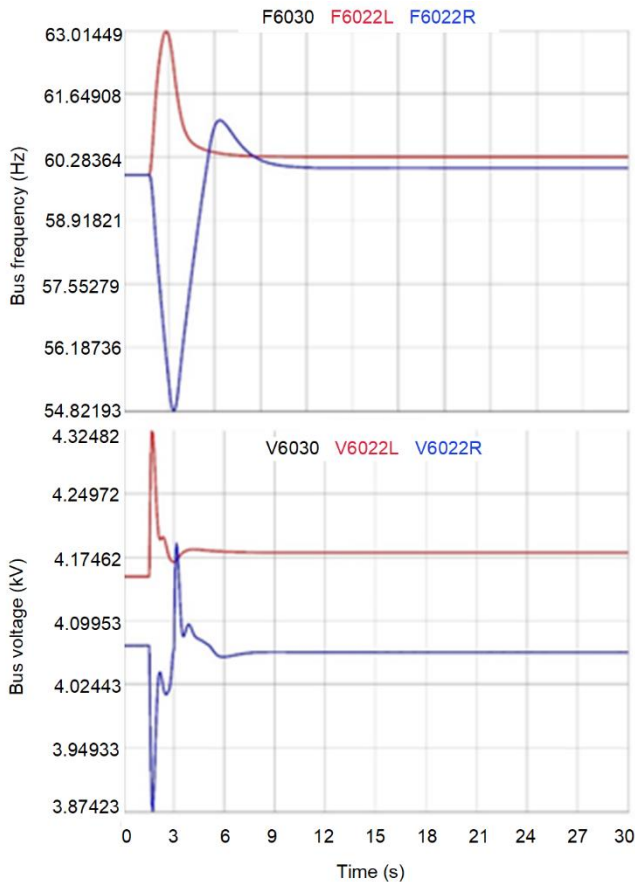

Fig. 16. Case 3: System voltage and frequency

VIII. CONCLUSION

This project augmented Red Dog's goal of resiliency, reliability, and survivability during system events. This paper demonstrates the design, development, and testing of the PMS implemented for the mine. Each PMS function is tested prior to running system-wide tests. CHIL testing helped to calculate all the required set points for the frequency- and contingency-based schemes while testing corner cases. CHIL testing also reduced overall commissioning time and is great for brownfield integration projects where production disruption can be critical.

The PMS has been commissioned into service at Red Dog mine and has been operating successfully for more than a year. In the words of the operators, the PMS has helped control generation without a constant need to adjust power between buses on either side of the reactor. It has also led to a more reliable local grid and helped avoid power failures on a few occasions which would have typically led to loss of production.

IX. ACKNOWLEDGMENTS

The authors gratefully acknowledge the contributions of Scott Barndt, Gabe Berbig, Daniel Rocco, Mahipathi Appannagari, and Asad Mohammed for their work supporting project development and commissioning efforts.

X. REFERENCES

- [1] K. Ravikumar, S. Manson, S. Raghupathula, T. Alghamdi, and J. Bugshan, "Complete Power Management System for an Industrial Refinery," proceedings of the 62nd Annual Petroleum and Chemical Industry Conference, Houston, TX, October 2015.
- [2] E. R. Hamilton, J. Undrill, P. S. Hamer, and S. Manson, "Considerations for Generation in an Islanded Operation," proceedings of the 56th Annual Petroleum and Chemical Industry Technical Conference, Anaheim, CA, September 2009.
- [3] M. M. Almulla, M. A. Fazil, and N. C. Seeley "Energy Management Systems for Islanded Industrial Facilities," proceedings of the 5th IEEE GCC Conference and Exhibition, Kuwait City, Kuwait, March 2009.
- [4] A. R. Khatib, B. Dai, and R. Costa, "Case Study: Turbine Load-Sharing and Load-Shedding System for an Australian LNG Facility," proceedings of the 66th Annual Petroleum and Chemical Industry Technical Conference, Vancouver, Canada, September 2019.
- [5] J. Dillot, A. Upreti, B. Nayak, and K. Ravikumar, "Microgrid Control System Protects University Campus from Grid Blackouts," proceedings of the 45th Annual Western Protective Relay Conference, Spokane, WA, October 2018.
- [6] S. Manson, A. Upreti, and M. Thompson, "Case Study: Smart Automatic Synchronization in Islanded Power Systems," proceedings of the 51st Annual Industrial and Commercial Power Systems Technical Conference, Calgary, Canada, May 2015.
- [7] "Hardware-in-the-Loop Testing of Electrical Protection and Control Systems," proceedings of the 65th Annual Petroleum and Chemical Industry Technical Conference, Cincinnati, OH, September 2018.
- [8] J. L. Blackburn and T. J. Domin, *Protective Relaying: Principles and Applications*, 4th ed., CRC Press, Boca Raton, FL, 2014.
- [9] IEEE 242-2001, *IEEE Recommended Practice for Protection and Coordination of Industrial and Commercial Power Systems*.
- [10] M. Joshi, S. Barndt, A. Anujan, C. Vellaithurai, M. Appannagari, and B. Nafsinger, "Reliable Protection Using a System Preservation Scheme," proceedings of the 47th Annual Western Protective Relay Conference, October 2020.

XI. BIOGRAPHIES

Mehul Joshi received his diploma in electrical engineering in 1988, his BS degree from Gujarat University, India, in 1995, and his MS degree in electrical power systems from the University of Detroit Mercy in 2004. Mehul worked for Gujarat Electricity Board in Gujarat, India, as a junior engineer for 13 years before joining Fording River Operations, an operation of Teck Resources Limited, in 2006. He is currently a senior electrical engineer at Red Dog mine, an operation of Teck Resources Limited. Mehul has experience in ac/dc drives, generator protection and excitation, power system protection design and commissioning, short-circuit and coordination studies, arc-flash studies, electric shovels, drills, and haul trucks. He is PE certified by the Association of Professional Engineers and Geoscientists of British Columbia (APEGBC).

Greg Smith is an electrical and instrumentation reliability technician with Teck Resources Limited at Red Dog Operations located in a remote part of Alaska. He has 43 years of experience in instrumentation and control of chemical facilities, nuclear power stations, mining operations, and oil and gas production facilities. The last 30 years are mainly in the commissioning, maintenance, modification, and expansion of power generation. He has a certification in instrumentation technology from ITI Technical College in Baton Rouge, Louisiana.

Pradeep Varma Sangaraju received his BE in electrical engineering from Anna University, Chennai, India, and his MS in electrical engineering from Arizona State University. Pradeep currently serves as an engineering supervisor with SEL Engineering Services, Inc. (SEL ES) and has over ten years of experience in the field of power system automation and control, including power management schemes for industrial customers and microgrid solutions. He is a registered professional engineer in the state of Arizona.

Ashish Upreti is an ES manager at SEL Engineering Services, Inc.(SEL ES), subsidiary of Schweitzer Engineering Laboratories, Inc., (SEL) in Pullman, Washington. He received his bachelor's and master's degrees in electrical engineering from the University of Idaho. He is a registered professional engineer in the state of Washington and a senior member of the IEEE. He has experience in the field of power system protection and automation, including power management schemes for large-scale industrial power plants. He has over ten years of experience in the field of power system protection and automation, including power management schemes for large-scale industrial power plants, remedial action schemes, and microgrid solutions.

Maaz Kazmi is a senior engineer at SEL Engineering Services, Inc.(SEL ES), subsidiary of Schweitzer Engineering Laboratories, Inc.(SEL). He joined in 2011. He earned his BE degree from NED University of Engineering and Technology in Karachi, Pakistan. Before joining SEL, he was a senior executive engineer in the energy and automation unit of Siemens Pakistan Engineering Company, Limited. He is an IEEE member and has over fifteen years of experience in design, development, testing, commissioning, technical documentation, business development, and customer training in the areas of power management solutions, substation automation, and HMI development. He has also acquired extensive knowledge in generation control systems for industries and utilities, utility system operations, and remedial action schemes.