

IEC61850 based distribution automation system testing with RTDS and 4G LTE

Alexandr Stinskiy, Ph.D.
Digital Grid
Siemens Industry
Menifee, CA, US
alexandr.stinskiy@siemens.com

Andre Smit
Digital Grid
Siemens Industry
Raleigh, NC, US
andre.smit@siemens.com

Christopher Huff, P.E.
Grid Technology Innovation
Southern California Edison
Westminster, CA, US
christopher.huff@sce.com

Abder Elandalousi, MSEE, MBA, P.E.
Grid Technology Innovation
Southern California Edison
Westminster, CA, US
abder.elandaloussi@sce.com

Don L Ro
Grid Technology Innovation
Southern California Edison
Westminster, CA, US
don.l.ro@sce.com

Michael Balestrieri
Grid Technology Innovation
Southern California Edison
Westminster, CA, US
michael.balestrieri@sce.com

Abstract— Southern California Edison is evaluating a new switch automation technology, referred to as the Remote Integrated Switch (RIS). The RIS includes a new control and communication scheme forming a distribution automation application with advanced functionality.

The previous RIS system development phase was successfully accomplished with a field deployment utilizing slow communication infrastructure and DNP3 communication protocol. Due to the inherent latency of the 900MHz legacy communication infrastructure, the average system response and reconfiguration after a fault event was approximately 2 minutes. This paper focuses on a new phase of the project, where the system employs the IEC 61850 protocol with GOOSE messaging. Utilizing the LTE communication infrastructure for the technology demonstration, system demonstrates a sub-second fault response time. The communication infrastructure includes 23 LTE modems connected over VPN to a cellular carrier. In order to test the system under different fault conditions, authors perform simultaneous secondary injection for 22 RIS devices using real time digital simulation (RTDS) equipment. The digital RTDS model is compiled based on data from the real circuits to ensure high fidelity of the system response and testing results. This paper will discuss the system's governing rules, design concept, test results from various fault events and lessons learned during this development phase of the RIS project.

Keywords – automation, distribution automation, artificial neural networks, decentralized logic, RTDS, cellular network

I. INTRODUCTION

The RIS system is designed to work on a grid with increased penetration of Distributed Energy Resources (DERs). DERs require advanced protection and control algorithms that can rapidly account for dynamic changes in load flow and energy resource availability while performing fault localization, isolation, and load restoration to maintain stability and reliability of the grid. The RIS is a decentralized system, where field automation controllers work together as a team to resolve fault scenarios, governing circuit switching responses in pre-defined geographical areas. Each participating controller or team member employs its system logic

based on a Neural Network while incorporating local measurements and information received from other team members into its decision process.

II. PROJECT DEVELOPMENT PHASES

The Low-speed system architecture application was implemented during previous phases of the RIS projects to seamlessly integrate into SCE's existing distribution protection and coordination schemes with minimal modification to existing infrastructure [1]. This architecture does not rely on substation SCADA communication for coordination with the substation relays. The substation breaker operation is detected by the Loss of Voltage Automatic (LVA) feature, resulting in the first downstream RIS isolation operation if the circuit's line voltage is missing for 30 seconds. For fault interruption, RIS controllers use protection curves coordinated with the substation relays and downstream devices [2]. This architecture employs existing SCE's communication system with a radio mesh network that communicates using an unlicensed 900 MHz spectrum. The radios employ a 9600 baud rate serial interface with DNP3 protocol support and packet size limitation of 207 bytes. The network covers SCE's entire 50,000 square-mile service territory, with approximately 55,000 radio terminals installed in the field. The inherent communication latency and packet size limitation result in relatively long system reconfiguration times.

To govern the system response to various fault scenarios, SCE designed a set of operational rules which shall be automatically followed by the RIS system [3]. The decentralized system logic architecture based on Neural Networks was developed to govern the individual RIS operations. This architecture provides fast and efficient operations as protection, and automation functions are residing within the microprocessor-based RIS controllers at the edge of the grid without a need for a central processing unit in the system to make all operational decisions.

A number of engineering challenges were encountered and subsequently resolved during development and deployment phases of Low-speed communication system [3]:

- Creating peer-to-peer data exchange with DNP3 protocol;
- Data packet size limitations;
- Overcurrent protection challenges;

- Miscoordination with the substation breakers;
- Operational group size limitation;
- System logic design;
- Complex system logic configuration;
- Communication performance in the field.

While authors accomplished their goal to demonstrate 14 RIS devices utilizing DNP, due to the limitations of the DNP3 protocol and relevant communication infrastructure, the authors confirmed the system could not extend beyond 14 devices for an operational group. With a device count increase, the system response time grows disproportionately due to communication latency. Any addition to the operational group would require reprogramming the entire system. The authors solved these problems in the High-speed system design utilizing the IEC61850 interface and circuit bridging concept.

III. TECHNOLOGY DEMONSTRATION GOALS

The latest phase of the SCE RIS project aims to demonstrate the High Speed RIS system utilizing benefits of the IEC61850 protocol with GOOSE messaging and IP-based communication network with high bandwidth and low communication latency. A public cellular communication infrastructure with virtual private network (VPN) was chosen to provide data exchange for the RIS system during technology demonstration. Set of 23 RX1400 4G/LTE Cellular Modem/Routers were configured to exchange GOOSE messages between RIS controllers on peer-to-peer fashion through a Verizon cellular network. The recloser controls in High Speed RIS system employ Siemens 7SC80 type automation controllers which continuously evaluate grid conditions and automatically perform switching actions to interrupt the faults, isolate faulted zones and reconfigure the circuit topology to available energy sources. The grid conditions, fault events and interrupter status feedback were provided by the real time digital simulation (RTDS) equipment governed by RSCAD software with high fidelity circuit model to form a hardware in a loop simulation for the entire RIS system. During the testing the live data from the RIS system is available on the HMI with multiple screens.

The project goal is to demonstrate the following functionalities of the High Speed RIS System:

- The fast (sub-second) system response which is essential to maintain distributed energy resources and minimize outage time;
- Operational benefits to grid operations;
- System scalability utilizing circuit based concepts for the operational group;
- Communication-based differential fault localization and overcurrent blocking to Isolate Faults;
- Remote configuration and programming abilities of the RIS controller;
- Ability to “bridge” operational groups through non-RIS devices;
- Coordination with non-RIS DA devices.

IV. HIGH SPEED SYSTEM DESCRIPTION

The High Speed RIS system topology is shown in Fig. 1. The system topology includes 6 distribution circuits forming a mesh distribution grid. The topology includes two, three, and four-way nodes where two three or four switching devices are connected

respectively. Each circuit is connected to a circuit breaker at the substation and includes one or more interrupters. In total, the system topology includes 22 RIS devices and one non-RIS device. It is important to mention the topology includes number of closed non-RIS in-line switches (not shown in Fig. 1). The non-RIS devices could be either manually operated load break switches or remotely controlled switches (RCSs) not operated by the RIS system. These devices are introduced to demonstrate a system behavior when default topology physically changes due to non-RIS switching actions. The important advantage of the High Speed RIS architecture (in comparison with a Slow Speed System architecture delivered earlier) is a circuit-based system design which was introduced to address scalability and deployability concerns raised during previous development phase. According to a circuit-based system design, the large operational group can be split into several individual circuits to optimize decentralized system logic and data traffic management. Using this approach to RIS system architecture the unlimited number of circuits can be connected together, forming a very large operational group with 50 or more RIS devices. Default system topology of the large Operational Group includes 6 Circuit Breakers, 7 RIS Tie and 9 Mid Switches. All RIS devices within individual circuits share their interrupter status and other operational data. The Tie Switches essentially define boundaries between circuits in the mesh connected grid. When Tie Switch is connected to a Mid Switches on another circuit, they form a logical and communication bridge to transfer data and operational decisions between the circuits. The system topology shown in Fig.1 converted to 6 individual circuits in Fig. 2. The layouts of the individual circuits are shown in Fig. 3 - Fig. 8. Please note that individual circuits have internal source and load zone assignment (S1-S8, Z1-Z8). Each device has direction 1 and 2 to define logical connections in the RIS System Logic. Circuit devices which directly connected to devices on the other circuit enable internal bridging logic to exchange data and operational decisions. The RIS System has HMI application designed to visualize the system topology, device statuses (open/closed), system targets, flags and analog readings. The HMI mimics the DMS receiving data from individual RISs in the system via DNP3 protocol.

To allow in-depth analysis of the system performance during testing and demonstration, multiple HMI screens were created. The main screen is shown in Fig. 9. The System modes of operation are located on the top bar, where Global Normal, Global Block, and Restore (Make Before Break or Break Before Make) commands can be issued to all RIS controllers. The TIR/IRT buttons allow to switch between Test Isolate Restore / Isolate Restore Test Modes. Another set of function buttons allow operator to reset Voltage Check Flag, Targets as well as Open/Close Failure flag on all RIS controllers. Sim Mode buttons enables a slow mode which intentionally slows down the system reaction to the fault events (it was introduced to demonstrate system response in step-by-step so the audience can witness individual switching actions). The screen navigation buttons are located on the side of the HMI. The operator can access individual circuit screens or exit the application. The main HMI window has multiple layers of information. User can click on the buttons to display currents, voltages, source budgets, zone allocation and ICRC results on the screen. It is important to mention that the latest version of the RIS system continuously performs state estimation and restoration path determination based on the present system topology and available energy resources from the substations as well as DER.

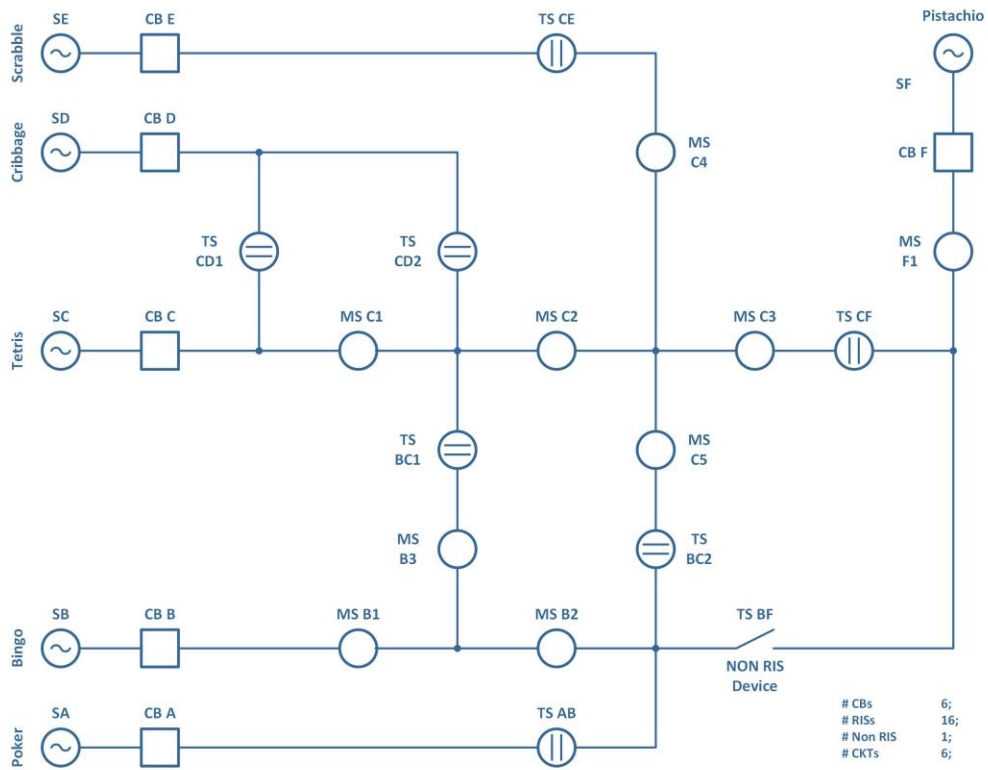

Fig. 1. RIS System Topology

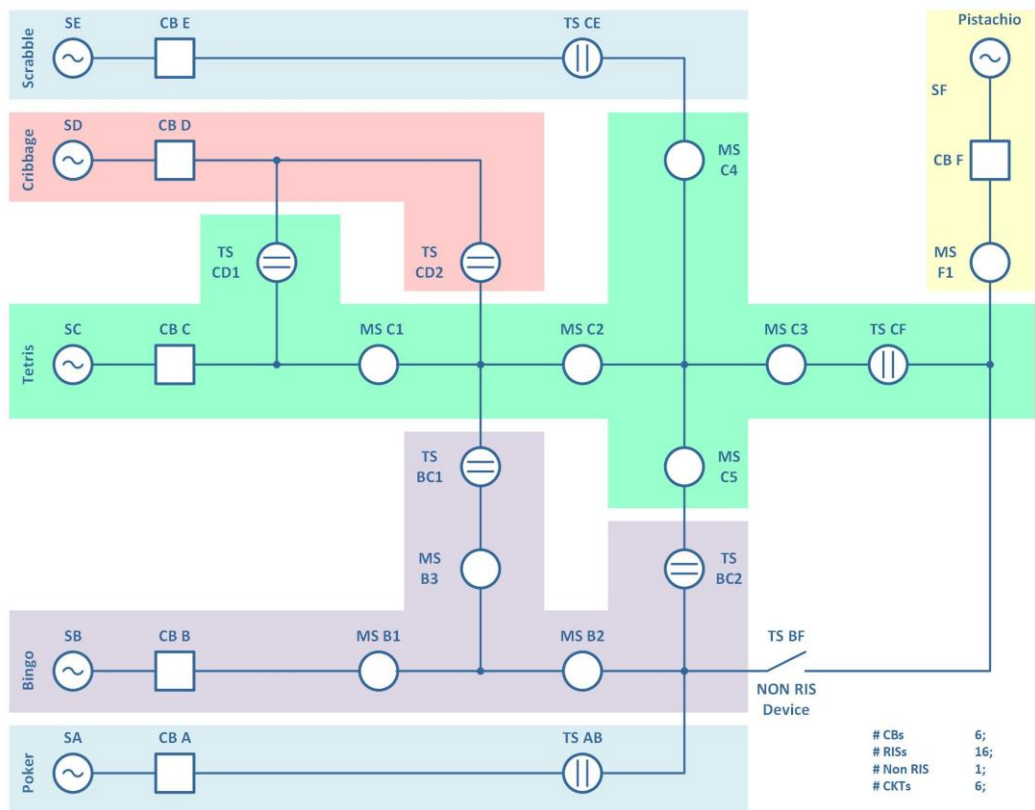

Fig. 2. RIS Circuits

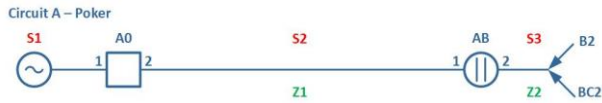

Fig. 3. RIS Circuit A

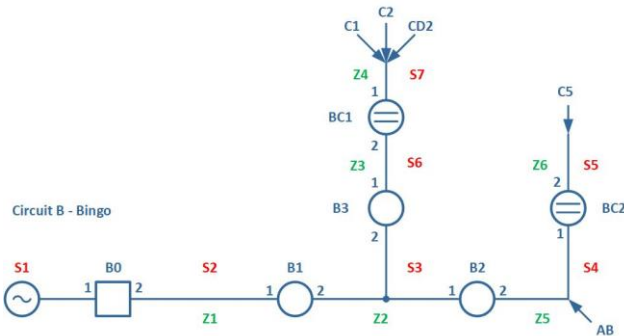

Fig. 4. RIS Circuit B

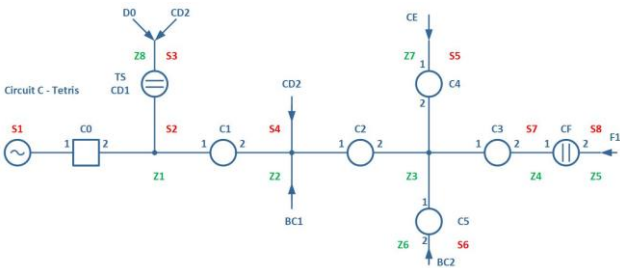

Fig. 5. RIS Circuit C

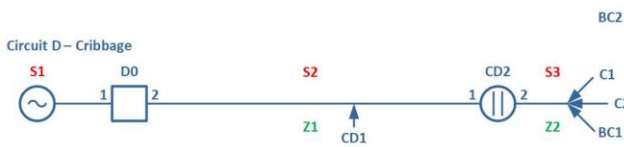

Fig. 6. RIS Circuit D

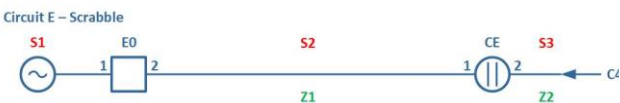

Fig. 7. RIS Circuit E

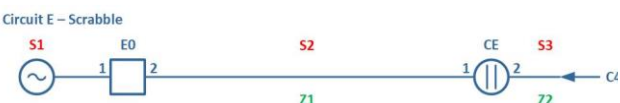

Fig. 8. RIS Circuit F

When fault occurs, system chooses the most recent restoration path identified by the Instantaneous Capacitance Restoration Check (ICRC) algorithm. Fig. 9 shows an example of the ICRC determination, where each Mid Switch RIS reports the circuit (CKT A, B, C, D, E, F) it prefers to transfer its load if fault occurs on the own circuit.

V. COMMUNICATION INFRASTRUCTURE CONFIGURATION

For the technology demonstration the High Speed RIS System employs Siemens RX1400 type 4G/LTE cellular modems/routers. These devices support peer-to-peer IEC61850 GOOSE traffic between RIS controllers as well as DNP traffic from all individual RISs to HMI PC. Modems are equipped with the SIM cards from Verizon with machine-to-machine (M2M) data plan and utilize VPN connection through the carrier network. The GOOSE traffic between RIS devices is tunneled through the communication network using IPsec tunnels. The communication setup with 23 RX1400 Modems in the DA lab is shown in Fig. 10 and Fig. 11.

The RIS devices in the High-Speed system employ three different GOOSE applications (i.e. GOOSE messages with unique content) to exchange data between devices in the system:

TABLE I – GOOSE APPLICATIONS

GOOSE	Min Time	Max Time	Description
FAPP	15500ms	30000ms	Fast Application – fault related indications prioritized for the fast processing
SAPP	18500ms	35000ms	Slow Application - load and budget values
BAPP	17500ms	30000ms	Bridge Application - data from the bridging logic to exchange with another circuit

Any device in the system carries FAPP and SAPP GOOSE applications to exchange data within the circuit. If RIS from one circuit is connected to RIS from another circuit, both devices exchange BAPP application to carry circuit related data. The IPsec tunnel configuration is shown in the Table II. Tunnels are labeled as T1-T12. The “X” in the vertical column identifies publisher/subscriber for the GOOSE messages in the tunnel. Same VLAN tag is in use for all GOOSE messages in the system. GOOSE is routed based on the destination MAC address, where last octet defines if message belongs to FAPP, SAPP or BAPP. A peer-to-peer latency for GOOSE messages observed during the testing with 4G/LTE network is 85-160ms.

VI. RTDS TEST SETUP

The Real Time Digital Simulation (RTDS) equipment was employed to perform system testing and demonstration. The RIS controllers were mounted on the 3 test racks. Additional standalone cabinet with single RIS controller was added to achieve required device count. High fidelity grid model was created in RSCAD software to perform the testing with secondary injection. The RTDS equipment along with 11 double amplifiers provided 9 analog channels and 4 binary signals per RIS device (6 Voltages, 3 currents, 2 binary inputs and 2 outputs), 6 analog channels (3 Voltages, 3 Currents) and 4 binary signals provided per substation breaker, with total count of 180 analog channels and 88 binary signals. The test setup with RTDS and RIS racks is shown in Fig. 12.

VII. TEST CASES FOR TECHNOLOGY DEMONSTRATION

During the system testing authors executed number of fault scenarios to verify the system performance and ensure correct

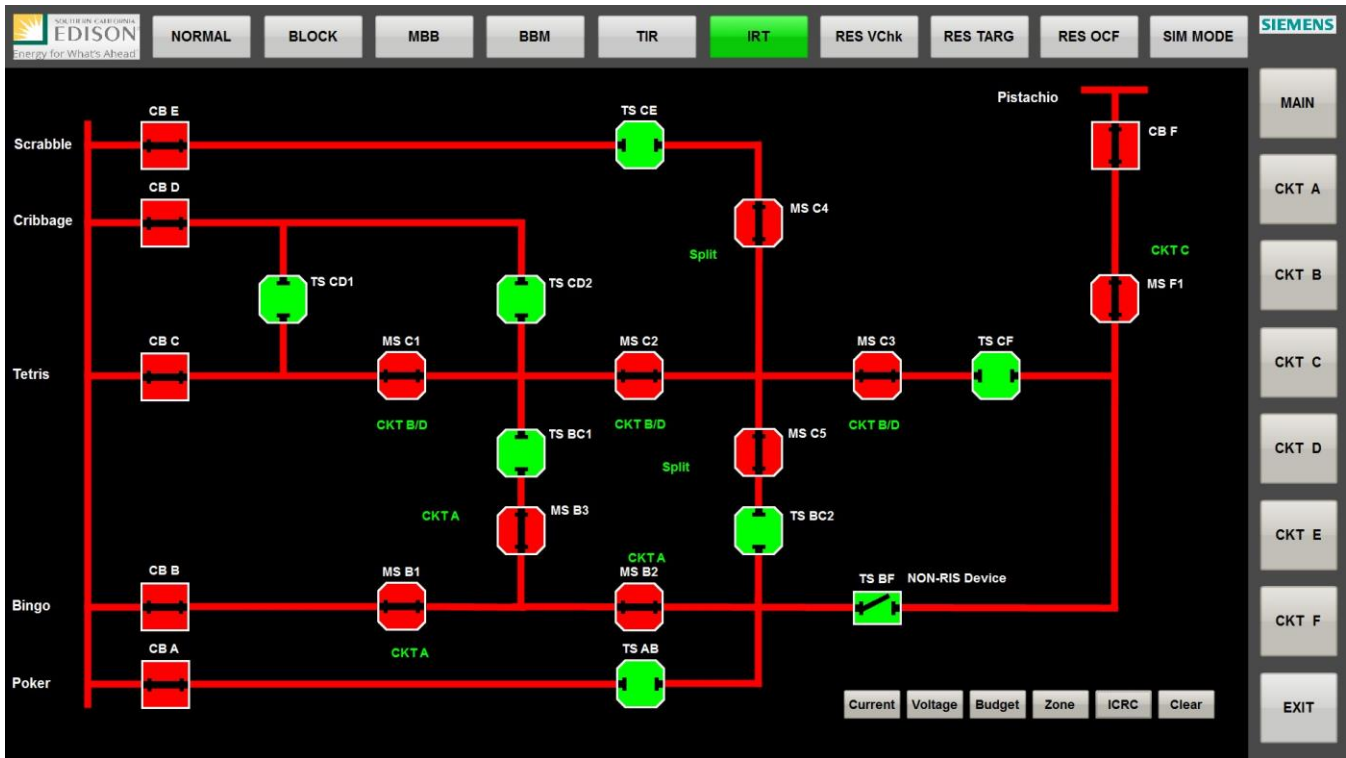

Fig. 9. Main HMI Screen



Fig. 10. Communication infrastructure with 23 RX1400 Modems



Fig.11. Communication infrastructure with 23 RX1400 Modems

operation. A few test cases were identified for the technology demonstration, including test cases with evolving faults, miscoordination, stuck interrupter, interaction with non-RIS device and a car hit pole scenario. One test case scenario is described below.

Purpose: Demonstrate the system's ability to identify and resolve an evolving fault beyond a circuit bridge (tie location).

- Isolate – Restore – Test (IRT) mode follows the process of isolate the fault, restore the unaffected zones, then test the faulted zone after 15 seconds;
- High-speed nature of Phase 3 enables use IRT sequence;
- Both the Isolate and Restore steps occur sub-second;

- In contrast, Phase II followed a Test-Isolate-Restore (TIR) sequence after relay trip only; the high speed system logic can toggle between IRT and TIR sequence;
- State estimation calculations are occurring in real-time prior to the fault occurring.

IRT is one of new features of the High-speed RIS system. This feature controls how the RIS system will sequence the Isolation, Restoration, and Test operations for the Operational Group. When enabled, the RIS system will attempt to isolate the faulted zone then restore un-faulted zones prior to testing the fault. After a trip event occurs, the RIS system will wait for the Test Delay timer (15 seconds) to elapse prior to attempting any test operations. In advance to the fault, the RIS system is performing state estimation calculations (we refer to them as "Budget") in real-time and identifies the best restoration scenario. So, before the fault occurs,

TABLE II – GOOSE Tunnel Configuration

RIS	T1	T2	T3	T4	T5	T6	T7	T8	T9	T10	T11	T12	GOOSE MAC Body	FAPP	SAPP	BAPP
C0	X												01-0C-CD-01-00	00	30	60
BC1						X					X		01-0C-CD-01-00	01	31	61
B1						X							01-0C-CD-01-00	02	32	62
C5	X								X				01-0C-CD-01-00	03	33	63
B2						X		X					01-0C-CD-01-00	04	34	64
CD1	X											X	01-0C-CD-01-00	05	35	65
CF1	X						X						01-0C-CD-01-00	06	36	66
AB1			X					X					01-0C-CD-01-00	07	37	67
C3	X												01-0C-CD-01-00	08	38	68
CD2					X						X	X	01-0C-CD-01-00	09	39	69
A0			X										01-0C-CD-01-00	10	40	70
C2	X										X		01-0C-CD-01-00	11	41	71
C1	X										X		01-0C-CD-01-00	12	42	72
BC2						X		X	X				01-0C-CD-01-00	13	43	73
B3						X							01-0C-CD-01-00	14	44	74
B0						X							01-0C-CD-01-00	15	45	75
C4	X									X			01-0C-CD-01-00	16	46	76
F0				X									01-0C-CD-01-00	17	47	77
F1				X			X						01-0C-CD-01-00	18	48	78
CE		X								X			01-0C-CD-01-00	19	49	79
E0		X											01-0C-CD-01-00	20	50	80
D0					X							X	01-0C-CD-01-00	21	51	81



Fig. 12. RIS System Test Setup

the system is aware of which circuits will pick up each zone, and a backup scenario.

A system response to the first fault is shown in Fig. 13. Load initialized to 60 Amps all zones; First Fault is injected in Zone 3.1. System responds to this fault in the following sequence:

- Step 1 - CB C trips on overcurrent protection;
- Step 2 - MS C1 opens according to the Zone Isolation Rule after receiving a new status of the circuit breaker;
- Step 3 – MS C4 and MS C5 open to split the load since all load cannot be transferred to a single circuit;
- Step 4 - Tie Switch CD2 closes since circuit D is identified as a primary restoration path due to available source budget; Tie Switches CE and BC2 close to pickup Zones 3.5 and 3.4 respectively.
- Step 5 - CB C performs an autoreclose after 15 seconds but trips due to a permanent fault.
- Second fault is applied in Zone 2.2. System automatically executes the following steps (final stage is shown in Fig. 14):
- Step 6 - RIS B1 trips on overcurrent;
- Step 7 - RIS B2 and RIS B3 open to isolate Zone 2.2 as part of Zone Isolation rule;

Restoration steps begin:

- Step 8 – Tie Switch BC2 opens and RIS C5 closes to transfer Zone 3.6 back to Ckt C. Due to Transfer Limit Rule any Zone in Ckt C cannot transfer to Ckt A;
- Step 9 - TS AB closes to transfer Zone 2.3 to Ckt A; Zone 2.4 will not transfer since Ckt C is already carried by another circuit (Ckt D);
- Step 10 - MS B1 performs an autoreclose attempt but trips due to permanent fault and locks out.

Third fault occurs in zone 5.1 (Fig. 15);

- Step 11 - Circuit Breaker CB E opens from overcurrent;
- Step 12 - New breaker status is communicated to TS CE which opens to isolate Zone 5.1 as part of Zone Isolation rule (RIS CE will not wait for CB E to retest as in TIR);

Restoration steps begin:

- Step 13 - MS C4 connects zone 3.5 back to circuit C.

VIII. LESSONS LEARNED

During the system testing authors encountered and successfully resolved a few engineering challenges associated with a new logic and amount of GOOSE traffic through a cellular network during the fault event. Under normal operating conditions devices periodically send GOOSE messages with intervals defined by the maximum retransmission time, which was chosen between 30s and 35s depending on the GOOSE application type to optimize the amount of traffic. Devices did not report any GOOSE messages being lost or communication link interruption.

When system detects a fault, number of devices in the circuit start sending GOOSE messages with relevant data to pinpoint the fault location. Following the fault detection, devices operate according to the fault isolation sequence, generating even more traffic. This phenomena is known as a “GOOSE avalanche” and could be problematic for the networks with limited bandwidth.

Authors observed that system was able to identify the faulted zone and perform first few isolation steps before network start dropping

vital GOOSE messages, thus preventing further reconfiguration steps. In order to fix this issue and optimize data exchange during the fault event, the following measures were implemented:

- Changing minimum GOOSE retransmission interval from 200ms to 15.5s, 17.5s and 18.5s for three different GOOSE applications respectively. These time intervals significantly decrease number of retransmitted messages before maximum retransmission time is reached (essentially only one message is retransmitted before max time is achieved). Different intervals were applied to ensure device will not transmit two or three different messages simultaneously.
- Providing one interrupter status signal “52a” instead of both “52a” and “52b”. With this change device generates only one GOOSE message following the operation instead of two, when both signals change. The Open/Close Failure flag was used to supervise the validity of the interrupter status (i.e. if 52a did not change due to a control cable or primary switch unit issue).
- Extending the lengths for the pulse signals to postpone GOOSE messages generated upon a signal dropouts. Different pulse times applied to ensure signals will not dropout at the same time.
- Introducing internal time delays for non-critical signals to avoid generating new GOOSE messages after receiving data from other team members.
- Freezing the load recalculations during the fault event to avoid sending out undesired GOOSE messages with analog values.

These measures significantly improved the network performance and system response. Devices were able to get all data and finish the reconfiguration steps in any fault scenario.

It is important to mention that all modems were mounted on the wall (Fig. 10) in the lab where cell coverage was not ideal. Authors did not use external antennas or cell repeaters in the building to test the system in worst case scenario. The field conditions in the densely populated areas with a good cell coverage and external antennas on top of the recloser control cabinet are expected to provide better signal to noise ratio and shorter latencies thus improving the operational speed of the system.

IX. CONCLUSION

The IEC61850 protocol with GOOSE messaging over 4G/LTE cellular network can be used for distribution automation system with decentralized logic architecture. This high-speed system can isolate faults and reconfigure the load with sub-second response time thus significantly minimizing outage time & exposure for unfaulted zones and improving SAIDI, SAIFI and MAIFI.

The system scalability was achieved using circuit-based system concept, demonstrating the RIS system with 6 circuits and 22 devices in the operational group. Based on this concept, the distribution automation system does not have a device limit in the operational group. Unlimited number of circuits can be automated, where each circuit can include up to 8 devices.

The low latency GOOSE data exchange allows fault detection to occur before overcurrent protection times out and trips.

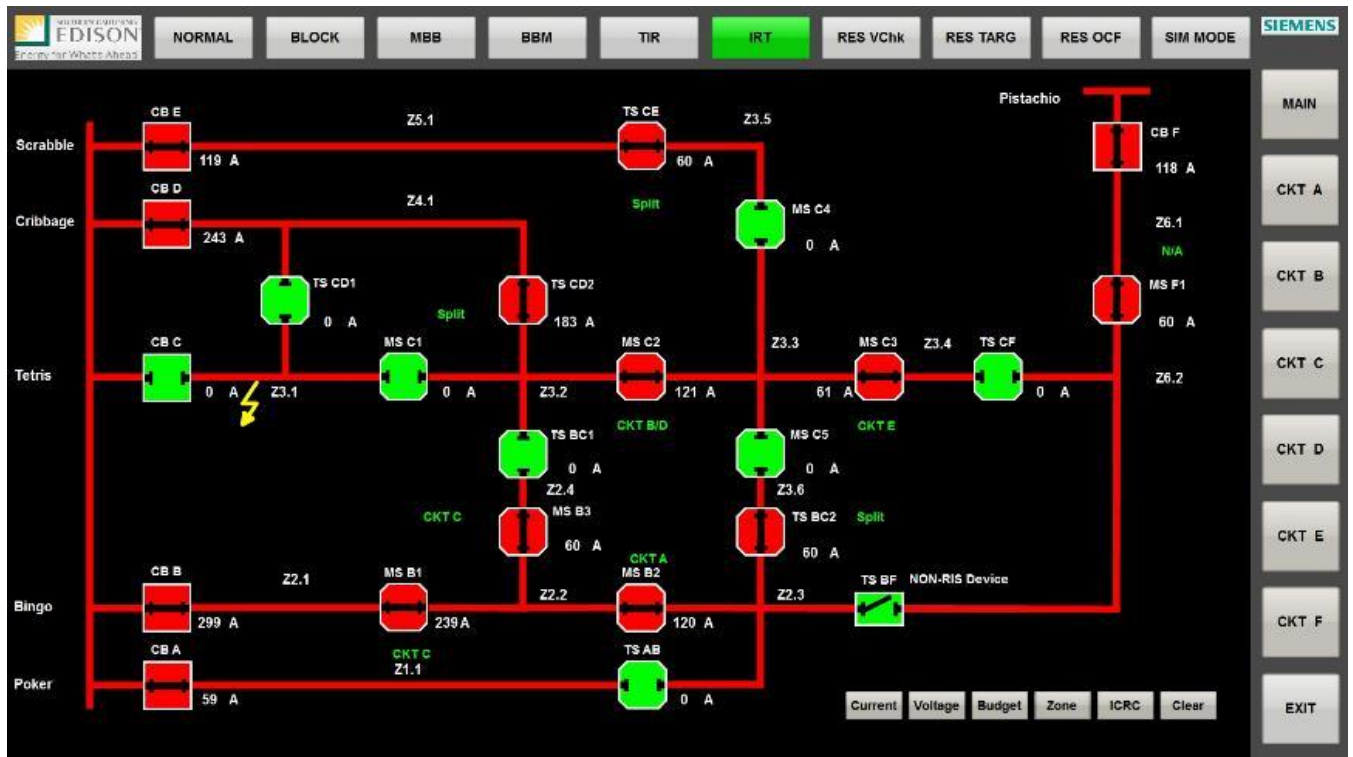
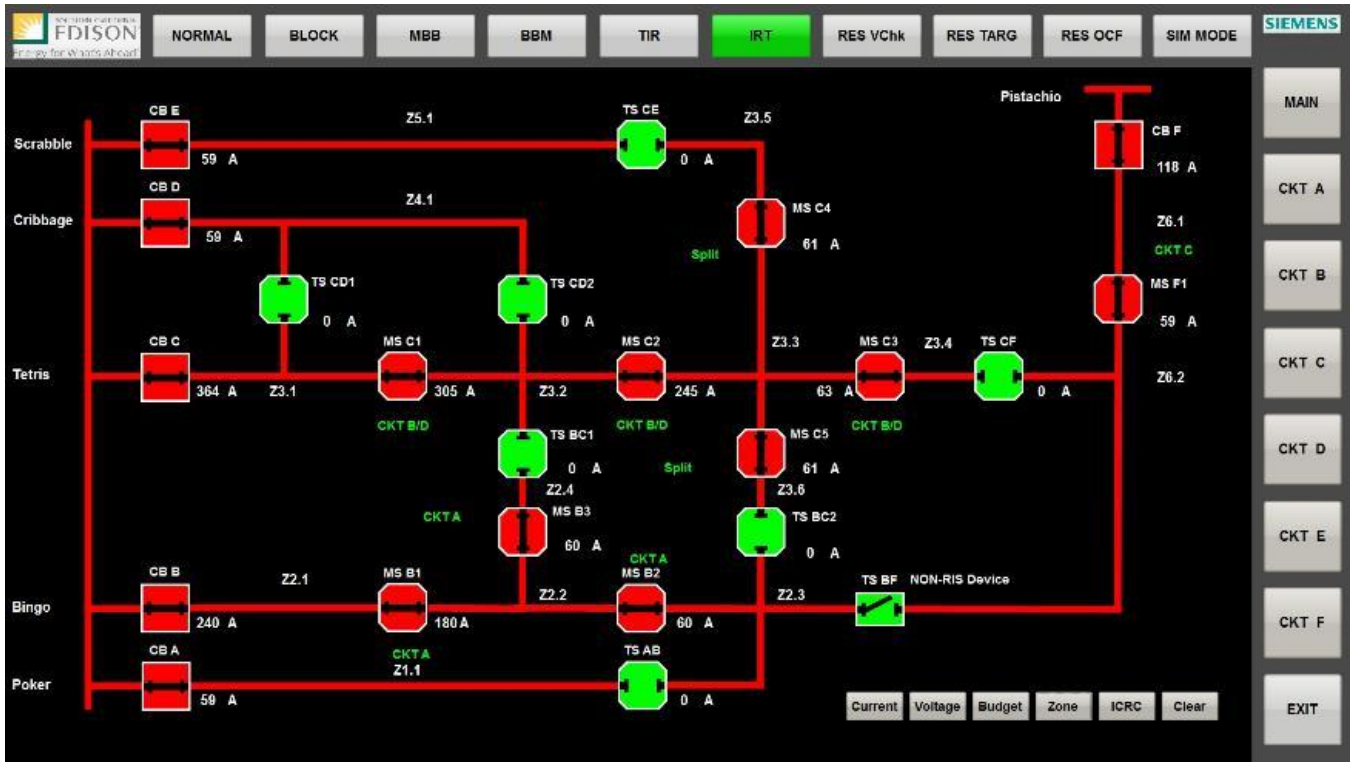

Fig.13. System response to a fault in Zone 3.1

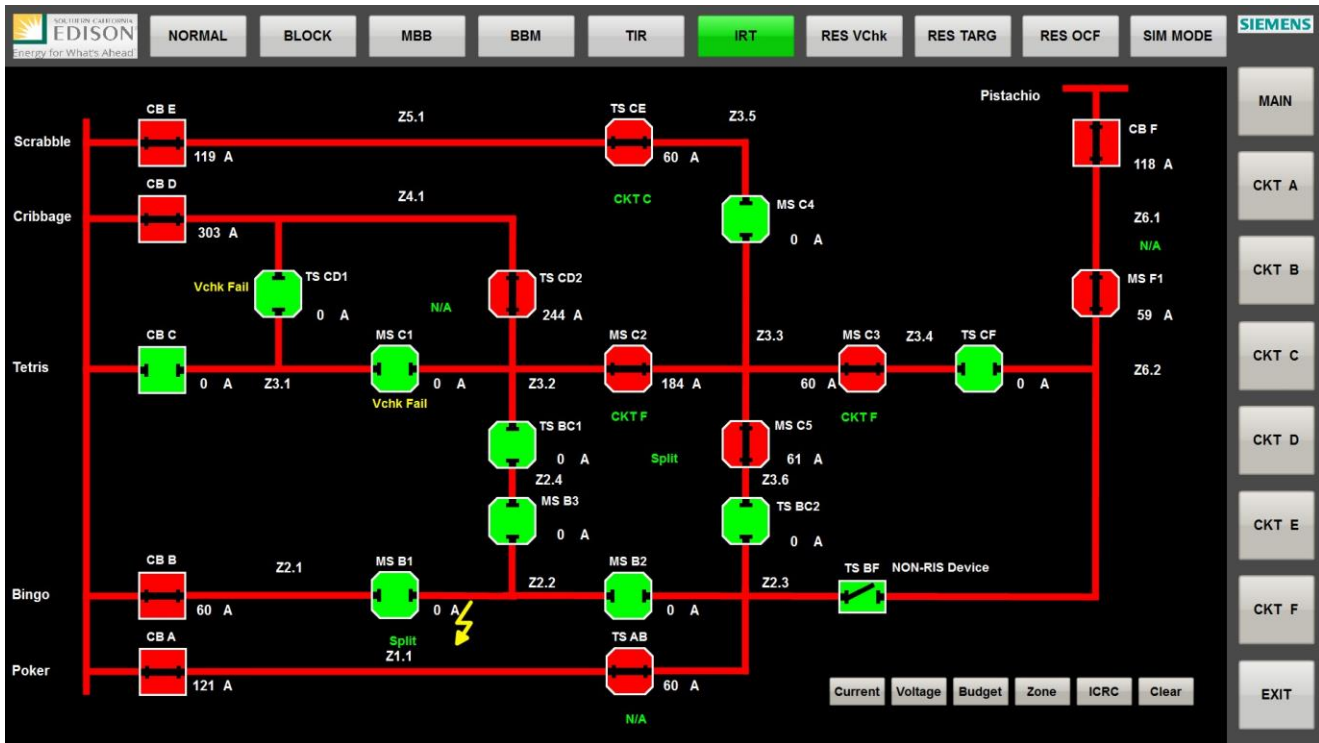

Fig.14. System response to evolving fault in Zone 2.2

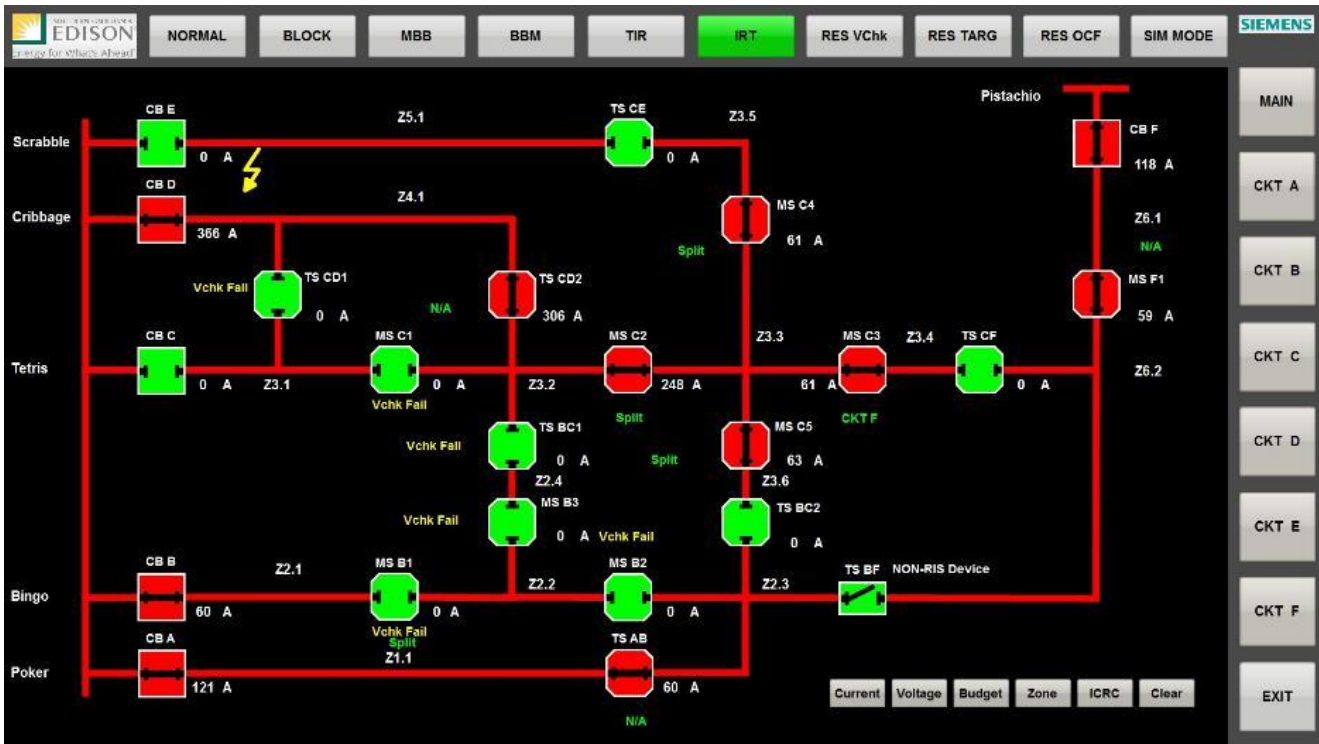

Fig. 15. System response to evolving fault in Zone 5.1

X. REFERENCES

- [1] B. Pham, C. Huff, N. Vendittis, A. Smit, Dr. A. Stinskiy, S. Chanda, "Implementing distributed intelligence by utilizing DNP3 protocol for distribution automation application" in Proc. 2017 PAC World Americas Conference, Raleigh, NC.
- [2] B. Pham, C. Huff, N. Duong, A. Smit, Dr. A. Stinskiy, "Advanced distribution automation application with mis-coordination correction algorithm based on neural network" in Proc. 2018 Georgia Tech Protective Relay Conference, Atlanta, GA.
- [3] B. Pham, E. Nunnally, C. Huff, N. Duong, A. Smit, Dr. A. Stinskiy, "Decentralized distribution automation system – scalability and deployment challenges" in Proc. 2019 PAC World Americas Conference, Raleigh, NC.
- [4] A. Smit and A. Stinskiy, "Systems, methods and apparatus for protecting power distribution feeder systems" U.S. Patent 8 908 342, Dec. 9, 2014.
- [5] K. Pettit, D. Bowman, A. Smit, Dr. A. Stinskiy, "Report on New Differential Protection Method after 6 Years in Service" in Proc. 2017 Georgia Tech Protective Relay Conference, Atlanta, GA.
- [6] C. Huff, A. Smit, A. Stinskiy, S. Chanda, "Utilizing IEC61850 standard for the circuit based wide area distribution automation system" in Proc. 2020 PAC World Americas Conference, Raleigh, NC.