

What's the Risk? One Utility's Approach to Strengthening Its Wildfire Resiliency

Douglas Taylor and Kevin Damron, *Avista Utilities*

Abstract—Operating in the Pacific Inland Northwest, Avista Utilities experiences a fire season beginning around mid-July and lasting until late September or early October. During this time, Avista has historically disabled instantaneous overcurrent (50) tripping as well as reclosing on its distribution protection, seeking to reduce spark ignition potential while maintaining coordination via time-overcurrent (51) elements.

As part of its on-going effort to strengthen its wildfire resiliency program, Avista devised a new approach to its distribution operations during fire season that seeks to calculate circuit-specific fire risks and allow operators to dynamically alter relay operating behaviors in response to the risk. The feeder relays and reclosers are programmed with three different “Dry Land Modes”, and each mode further reduces electrical fault energy by reprioritizing 50 elements over 51 elements and reducing or disabling reclosing. Avista calculates a fire risk potential taking into account various weather, environmental, and operational data for the different distribution circuits. Based on a real-time fire risk calculation, the protective devices on a specific circuit can be moved into the appropriate Dry Land Mode, allowing for a dynamic scheme that attempts to balance fire resiliency with service reliability.

This paper will discuss the background to Avista's wildfire resiliency plan and Dry Land Modes of operation, the components that Avista uses to calculate a fire risk for its distribution circuits, the various integration and implementation details to support dynamic operation, and the protection considerations employed that balance speed, sensitivity, and security.

I. INTRODUCTION

Over the last decade, electrically-induced wildfires have gone from a weather-related event to one of the primary enterprise risks that utilities face. New technologies aimed at reducing wildfire risk continue to emerge. Preventative maintenance methods now employ large scale imagery resources such as satellite images to help identify vegetation encroachment or at-risk trees outside of right-of-ways [1]. LiDAR, and high-resolution photography can help speed up equipment evaluations to detect problems such as cracking cross arms or bond wire damage. Some measures even involve the installation of high-frequency sensors on lines that are trained to identify breaks in conductor strands [2].

From an electrical energy reduction perspective, there are numerous approaches to reducing the energy (I^2t) component of an electrical fault and the likelihood of spark ignition. Ungrounded, resistive- or resonant-grounded systems seek to significantly reduce ground fault currents. For solidly grounded systems, reducing relay reclose counts or enabling instantaneous overcurrent (50) elements are options. To prevent phase-to-phase faults, installing conductor spacers helps prevent conductor slap conditions during high wind conditions

or other system events. Relays equipped with high-impedance fault (HIF) detection algorithms seek to identify the low-level, erratic ground currents involved in HIF events that otherwise go undetected using traditional protection methods [3].

This paper focuses on Avista Utilities' wildfire resiliency efforts. Section II begins with briefly mentioning Avista's historical approach to wildfire protection before describing recent updates made to its wildfire resiliency plan, which includes dynamic protection operating schemes in response to changing fire risk. Section III describes the components involved in the Fire Risk Potential calculations that Avista uses to assess wildfire risk. Section IV discusses some of the infrastructure requirements necessary to make such a dynamic scheme possible. Finally, Section V details specifics on the protection settings that balance scheme speed, sensitivity, and security.

II. AVISTA'S WILDFIRE RESILIENCY PLAN

Historically, Avista's approach to wildfire resiliency has included activities such as cyclic vegetation management, patrolling for high-risk (i.e. dead/dying/diseased) trees, applying fire retardant paint to wood poles, and pole and line inspections, to name a few. Since the early 2000's, Avista has utilized a Dry Land Mode (DLM) of operation for portions of its distribution system. DLM operations included input from area engineers, district managers, and vegetation management experts and was typically called for in the Mid-July time frame. While in DLM, designated feeder relays and reclosers were set to reduce the fault energy by disabling 50 elements and disabling reclosing (43I and 43R switches, respectively, turned off). For reference, normal (non-DLM) operation of Avista's rural distribution protection consists of an initial trip via 50 elements (fuse saving), followed by two recloses (0.5 s and 12 s) with subsequent trips initiated via time-overcurrent (51) elements (fuse tripping). The DLM scheme sought to strike a balance between fault energy/re-ignition reduction and maintaining protection coordination.

Beginning in 2019, Avista's Wildfire Resiliency team began an overview of its wildfire prevention measures and identified key improvements and additions for its program [4]. Some examples include improvements to vegetation management such as the use of satellite imagery to better monitor for encroachment into power lines or identify at-risk trees [1], which according to Avista records are three times as likely to contact lines as grow-in trees are. Grid hardening improvements include activities such as introducing fire-mesh wraps around the base of critical wood poles, whose longevity

surpasses fire retardant paint fourfold, or replacing wooden cross arms with a fiberglass version.

A critical analysis of the DLM operating scheme for the distribution protection devices identified several key improvements and is the focus of this paper. First, Avista performed an analysis of the fault energy experienced when operating the distribution system in its legacy DLM scheme (51 element trip to lockout). Part of the analysis included a survey of distribution faults to identify the percentage of faults which are temporary compared to permanent. Comparing Avista’s SCADA breaker operation history against its Outage Management System (OMS) records revealed between 30-50% of Avista’s distribution system faults were temporary in nature.

Weighing the likelihood of temporary faults against the typical operating times for a fuse or a 51 element under a range of fault duties, fuse sizes, and pickup/time-dial settings, Avista determined, on average, the fault energy would decrease if the DLM scheme was changed to initially operate via a 50 element. For the 30-50% of faults that are temporary, service is restored, and fault energy is significantly reduced via the 50 element operation time compared to that of a fuse or 51 element. To address service reliability for permanent fault situations, Avista determined to add a single reclose, disable 50 elements and activate 51 elements (which trip to lockout for trunk faults). This new mode of operation is referred to as “Base Dry Land Mode” or Base DLM.

Another key improvement to the DLM scheme included adding additional operating levels to the scheme that further reduce the fault energy and switching to those operating levels as the fire risk for a specific circuit increases. Avista added two additional operating modes to the scheme, “Fire 2-Shot”, which only uses 50 elements and a single reclose, and “Fire 1-Shot”, which trips on 50 elements without reclosing. When reclosing is present, a 12 second open interval was selected to give additional time for a temporary fault to clear. Operating solely on 50 elements in these elevated fire risk modes is an attempt to trip the breaker before a fuse actuates for a lateral fault, recognizing that not all fuses can be saved depending on their size and the fault duty at or beyond their location. Fig. 1 shows a summary of Avista’s distribution feeder relay and recloser protection modes, including its legacy (old) DLM scheme.

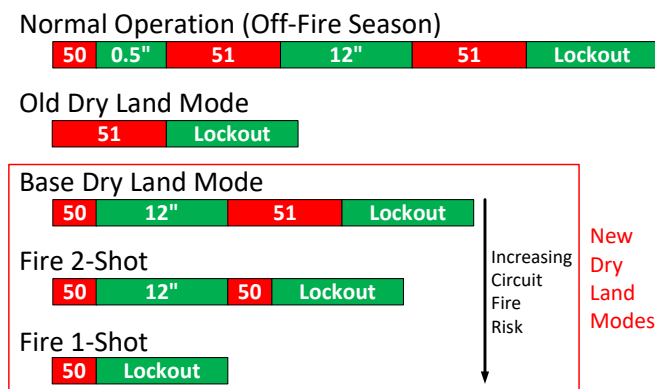

Fig. 1. Avista’s Distribution Feeder Relay and Recloser Operating Modes

These changes to DLM operations represent a significant shift over the old DLM operation and required substantial

changes to the relay settings in order to support them, which is the topic of Section V. The factors that govern the Fire Risk Potential calculations, which determine when to move between the various Dry Land Modes, is discussed in the next section.

III. FIRE RISK POTENTIAL

Since their inception, utilities have been data-hungry. Monitoring equipment health, power measurements, and voltage levels have been key measures from the beginning. Aided by the introduction of SCADA systems, digital relays, intelligent electronic devices, and, most recently, wireless meters, utilities now have mounds of data available which they can use to improve system efficiency and reliability. Additionally, improvements in Geographical Information System (GIS) data and its increased accessibility, along with a wealth of “online” weather information either through national agencies or personal weather sensors allow for a real-time, circuit-specific approach to fire risk calculations.

In risk analysis, risk is defined as the product of probability and impact. Avista calculates Fire Risk Potential (FRP) scores across its distribution system that take into account the probability of an ignition event and the impact of that event, should it occur. Probability factors mainly consist of weather, environmental, and circuit performance data, including some of the following:

- Wind gusts (2 second max in a 1-hour period)
- Sustained winds (30 second max in a 1-hour period)
- Wind direction
- Relative humidity
- Fuel type (USDA Wildfire Hazard Potential Map [5])
- USDM drought index [6]
- Fire preparedness levels [7]
- Feeder OMS data (tree- and weather-related)
- Feeder health (e.g. equipment age, SAIDI, SAIFI)

Impact factors utilized in the Fire Risk Potential score focus mainly on public safety risks and societal costs of a wildfire event and are more difficult to quantify. One tool that helps with the evaluation process is a Wildland Urban Interface (WUI) map. According to the U.S. Fire Administration, “the WUI is the zone of transition between unoccupied land and human development.” A WUI map helps assess fire-risk spatially across an area. The map lays out a grid on the utilities service territories and identifies three main items within each grid space:

- Infrastructure (i.e. overhead conductor)
- Development (i.e. population density)
- Fuel type (USDA Wildfire Hazard Potential Map [5])

Additional factors can be added to the WUI map to further refine it, such as ignition probability (OMS data) and fire-spread risk (fire history, fire protection and readiness).

Avista established a rule set for each of the WUI factors and ran the rule set against its GIS datasets to produce the WUI map shown in Fig. 2. The map is divided into Tiers 0 through 3, corresponding to low (0), medium (1), moderate-high (2), and high-extreme (3) fire risks. Tier 0 areas are those with low fuel concentrations, very low housing density, or large urban areas

(>10,000 pop.) which disperse fuel canopies or have readily available fire protection. Tier 3 areas tend to include small communities surrounded by forest land.

In addition to aiding FRP scores, the WUI map provides a clear tool to help area engineers reevaluate which circuits in their districts to include in DLM operations and specific feeder device selection (i.e. feeder relays and reclosers) to provide optimal protection on per feeder basis.

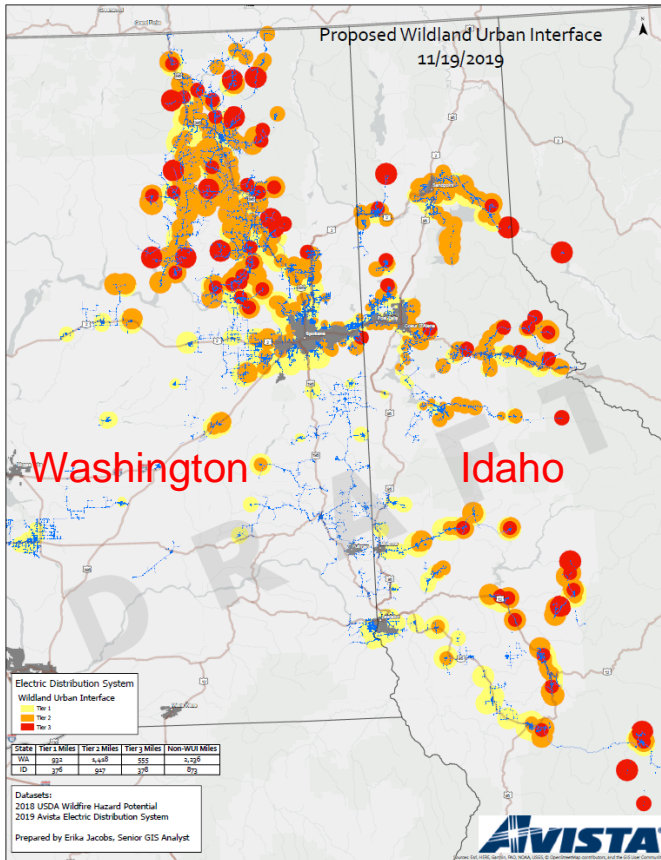

Fig. 2. Avista’s WUI Map. Tier 1 Regions are Shown in Yellow, Tier 2 in Orange, and Tier 3 in Red

With the specific fire probability and impact factors identified across its service territory, Avista combines that information together with appropriate weighting and indexing to calculate an FRP for each circuit in its DLM program. Summer 2020 marked the initial iteration of the FRP calculations. Using historical fire, weather, and outage data, the process was used to back-calculate FRP levels and test their accuracy. The Wildfire Resiliency team continues to refine the calculations as new data comes in.

The FRP calculations are presented in a Fire-Weather Dashboard with an 8-day forecast, organized by service districts (Fig. 3). During fire season, area engineers, district managers, and distribution operators meet at the start of each week, review the FRP scores, and plan the DLM operating modes for all DLM circuits. Based on the scores, feeder relays and reclosers are remotely moved into the appropriate DLM operating level (Fig. 1). If a sudden change occurs in weather conditions, the FRP calculations update to reflect the new risk levels and operators can quickly adjust the relay’s DLM

operation accordingly. The capture in Fig. 3 shows a mixture of newer DLM devices (as indicated by “Base”) and older DLM devices that haven’t been upgraded yet.

Max	Area Office	Feeder	Status	DLM	08-09	08-10	08-11	08-12	08-13	08-14	08-15	08-16
6.2	Colville	GIF12F1	OLD	YES	5.6	4.8	6.2	5.9	4.9	5.7	5.4	5.1
6.2	Colville	GIF34F1	BASE	YES	4.7	4.7	6.2	5.7	5.0	5.4	5.4	5.2
6.2	Colville	CIHW12F3	BASE	YES	4.5	4.9	6.2	5.7	5.1	5.4	5.4	4.9
5.4	CDA	RAT233	BASE	YES	4.0	4.0	5.4	4.7	4.7	4.8	5.1	4.6
5.3	CDA	DAL131	BASE	YES	4.2	4.7	5.3	4.7	4.9	5.0	5.1	4.8
5.3	CDA	SPL361	OLD	YES	4.0	4.5	5.3	4.6	4.9	5.0	4.7	4.6
5.9	Davenport	ODS12F1	OFF	NO	4.2	4.7	5.5	5.9	5.4	5.5	5.6	5.3
5.8	Davenport	LTF34F1	OLD	YES	4.4	4.5	5.8	5.3	5.1	5.2	5.4	5.1
5.7	Davenport	FOR12F1	OLD	YES	4.3	4.5	5.7	5.1	5.2	5.3	5.3	5.1
5.6	Deer Park	DEP12F1	BASE	YES	4.0	4.2	5.6	4.4	4.6	4.9	5.0	4.7
5.5	Deer Park	LOO12F2	OLD	YES	3.6	3.9	5.5	4.6	4.7	4.9	4.8	4.3
5.3	Deer Park	MLN12F1	OLD	YES	3.8	3.9	5.3	4.6	4.8	4.9	4.7	4.5

Fig. 3. A Portion of the Fire-Weather Dashboard, Which Displays an 8-Day Forecast of Feeder Fire Risk Potential (FRP) Scores

The equipment and infrastructure necessary to allow for the aforementioned dynamic fire risk response will be discussed in the next section.

IV. DLM PROTECTION INFRASTRUCTURE REQUIREMENTS

In order to make real-time adjustments to system protection operations in response to changing fire-threat conditions, two key components must be in place:

- Digital relays, which allow for separate setting groups (for differing trip and reclose behavior), user-customizable logic, and integration capabilities.
- SCADA and Distribution Management System (DMS) infrastructure, which allows for remote data from and operational control of the relays.

Thankfully, Avista had a jump start on deploying these resources throughout its distribution network by way of its smart grid projects.

In 2010 the U.S. Department of Energy awarded Avista two grants, which were the largest matching smart grid investment grants in Washington State. The two grants were 1) the Smart Grid Investment Grant Project for the installation of intelligent field devices, communication connectivity and software systems enabling a smart grid and 2) the Smart Grid Regional Demonstration Project for the development of interoperability architecture to demonstrate the benefits of deploying smart grid technology within a region [8].

The funding allowed Avista to accelerate the pace of upgrades planned for its distribution system. Over a two-year period Avista deployed its DMS infrastructure, digital feeder and reclosing relays, various communication systems, and substation integration equipment benefiting more than 110,000 electric customers in the Spokane and Pullman regions.

Several technologies were used for the communication networks including cellular radio and wireless mesh networks with selection based on the specific deployment location. The smart grid initiative also provided the opportunity to upgrade the communications infrastructure in the associated substations. If necessary, the feeder relays were upgraded for the smart grid circuits.

Prior to 2010, Avista primarily had older reclosers on its distribution system with no integration capabilities. The installation and integration of “smart” reclosers and switches provided Avista with remote operational data and control via Distributed Network Protocol (DNP) communications.

Following the smart grid projects, Avista had standardized equipment, processes, and settings templates in place that allowed any new distribution protection installation or upgrade, whether urban or rural, to tie into the DMS system, the exception being areas incapable of supporting mesh or cellular networks. The buildout of Avista’s DMS-enabled protective devices was to the extent that following the reevaluated DLM device roster in 2020, 40% of the feeder relays and reclosers on the DLM list already had operational control capabilities making them immediately eligible for the new dynamic DLM scheme and were upgraded to the new scheme over the course of 2021.

Fig. 4 is a screenshot from Avista’s DMS system showing one of the DMS-enabled reclosers, SPI 12F1 ZE172R, which is part of the DLM roster and was upgraded during summer 2021. Following firmware and settings upgrades to the recloser and completion of the commissioning process, the operator moved the recloser from Old DLM into Base DLM, as indicated in the figure.

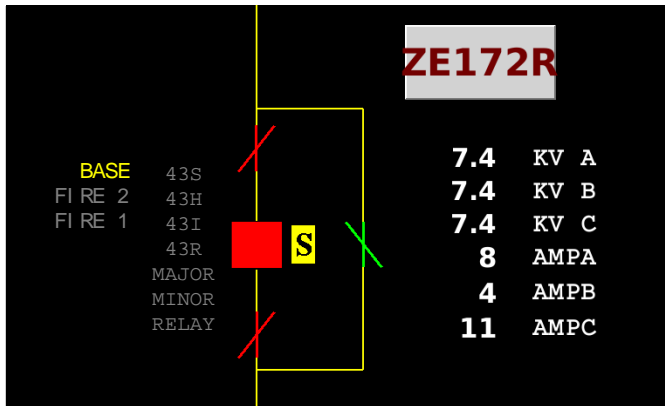

Fig. 4. DMS Screenshot Showing SPI 12F1 ZE172R Recloser in Base DLM

The specifics of the protection settings to make the new DLM scheme possible will be discussed in the next section.

V. DLM PROTECTION SCHEME

As discussed in Section II and shown in Fig. 1, Avista’s new DLM protection scheme seeks to reduce the fault energy and chance of spark ignition of normal (off-fire season) operation by reducing or removing the reclose shot count and emphasizing 50 element operation as the fire risk (FRP score) to a specific circuit increases. The following subsections will describe the specific methods Avista uses for creating the DLM relay settings that attempt to balance speed, sensitivity, and security, including overcurrent pickup settings, breaker-coordination delays, and inrush security methods.

A. DLM Overcurrent Pickup Settings

Avista’s distribution overcurrent pickup settings standard is shown in Table I. As with any protection, Avista’s goal for

distribution protection is to be as sensitive as possible while maintaining security. At a minimum, a 2:1 sensitivity is sought after, meaning that the overcurrent pickup setting will be, at most, half the value of the minimum fault duty the relay is responsible to cover (Avista always works with bolted, $R_F=0\Omega$, fault values).

For the normal (off-fire season) settings in Table I, the 51P element is usually set at twice the maximum load seen by the relay, to provide security against cold load pickup. Considerations for conductor ampacity and future load growth can be taken into account, so long as a 2:1 sensitivity is achieved for the minimum three-phase (3LG) fault duty the relay must protect for. The 51G element is set based on the maximum downstream (DS) fuse size per Avista’s fuse coordination standard (e.g. 51G=480A for 140T), assuming at least a 2:1 sensitivity for the minimum single-line-to-ground (1LG) fault duty. The 51Q element ($I_Q=3\cdot I_2$), is set as $\sqrt{3}\cdot 51G$, which ensures security for 1LG faults while providing phase current sensitivity to line-to-line (LL) faults equal to the phase current sensitivity to 1LG faults. Table I also indicates that the 50P and 50G elements are set equal to the 51P and 51G elements, respectively, and that Avista hasn’t used 50Q in its normal protection settings. The 50 elements are set to trip instantaneously with no definite-time delay.

TABLE I
AVISTA’S DISTRIBUTION OVERCURRENT PICKUP SETTINGS STANDARD

Element	Normal Operation (Setting Group 1)	DLM Operation (Setting Group 2)
51P	2x Max Load	2x Max Load
51G	Based on DS fuse size	Based on DS fuse size
51Q	$\sqrt{3}\cdot 51G$	$\sqrt{3}\cdot 51G$
50P	Set equal to 51P	50P _{OR} : 2:1 “EOL” Sensitivity 50P _{UR} : 1.1·(3LG _{DS_DLM_Device})
50G	Set equal to 51G	50G _{OR} : 2:1 “EOL” Sensitivity 50G _{UR} : 1.1·(1LG _{DS_DLM_Device})
50Q	N/A	50Q _{OR} : $\sqrt{3}\cdot 50G_{OR}$ 50Q _{UR} : 1.1·($\sqrt{3}\cdot LL_{DS_DLM_Device}$)

The result of the aforementioned settings rules, in many cases, is the feeder relay’s overcurrent zones will reach beyond the furthest downstream relay, as shown in Fig. 5a, where the feeder relay, FR, sees beyond the furthest recloser, R2.

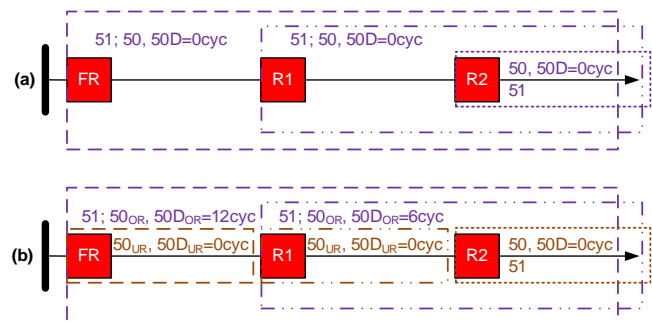

Fig. 5. Distribution Protection Reach for Feeder Relay (FR) and Reclosers (R1, R2) in Normal Operation (a) and DLM Operation (b)

The overreach shown in Fig. 5a is not usually an issue since, in normal operation, the 50 elements are only active for the first trip and the first reclose open interval is 0.5 s long (Fig. 1). If the overreach does prove problematic, the area engineer can either request the 50 elements be set with an underreaching pickup or request instantaneous tripping be disabled entirely via the relay's 43I switch.

With DLM operation, the single reclose interval for Base DLM and Fire 2-Shot operation was set at 12 s in order to give additional time for a fault to clear out and avoid re-ignition (Fig. 1). More importantly, the 50 elements are the only elements to be active for the Fire 2-Shot and Fire 1-Shot operating modes; there is no time dial coordination while operating in these two modes. In order to balance operating speed and relay security, Avista sets overreaching (50_{OR}) and underreaching (50_{UR}) overcurrent elements, operating in parallel, for its DLM operations, as indicated in Fig. 5b. The 50_{OR} elements have a breaker-coordinated, definite-time-delay added to them ($50D_{OR}$, discussed in the next subsection), while the 50_{UR} elements operate instantaneously. The furthest downstream DLM device (R2) doesn't require both sets of overcurrent elements but the 50_{UR} elements can be set based on fault duties at a landmark downstream of the DLM device and DNP binary points of the 50_{UR} elements can be sent to DMS to help aid line patrolling and fault locating.

As shown in the DLM column of Table I, the 50_{OR} elements are set to ensure fault sensitivity for each relay's "end of line" (EOL). Avista's Protection group worked with the area engineers to develop a Feeder Protection Map (FPM) for each DLM device in their district. The map needed to include the following information:

- Summer (May-October) max load, 3LG, & 1LG fault duties at each DLM device
- DLM device "EOL" 3LG, 1LG, & LL fault duties
- Max downstream fuse sizes from each DLM device
- WUI zones marked on the map

An example FPM is shown in Fig. 6. With the FPM, the 50_{OR} elements can be set to ensure that the "end of line" laterals for each device are protected with sufficient sensitivity, which in normal operations are considered to be protected by fuses. Avista is winter peaking, so knowing summer max loads at the DLM devices allows the $50P_{OR}$ element to be set more sensitively than the yearly max allows and still be secure against cold load. Knowing summer loading along with max fuse size allows for additional sensitivity in the $50G_{OR}$ pickup value, if necessary. Having the WUI zones on the maps ensures critical portions of the circuit are covered when facing unique load- and/or fuse-limiting situations.

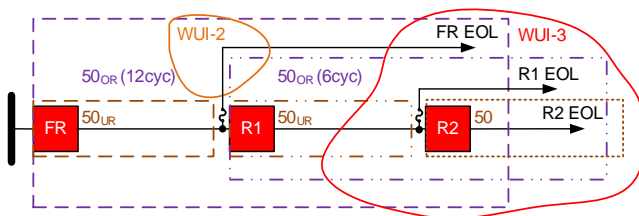

Fig. 6. Example Feeder Protection Map

Table I indicates that the 50_{UR} elements are set at 110% of the downstream DLM device fault duties. If there is further confidence in the fault values for a specific feeder, the underreach percentage can be lowered. Again, these fault duties are for bolted faults, so aside from modeling inaccuracies, overreach is not a concern.

Note from Table I the $50Q$ elements are utilized for DLM operation. The $50Q$ elements offer additional sensitivity to LL faults over that of the $50P$ element. The symmetry of the positive- and negative-sequence networks means that the LL phase fault duty will be $\sqrt{3}/2$ (0.87) as large as the 3LG fault duty at a given location. The difference in fault values means the $50Q_{UR}$ element, when set according to Table I, is 15.5% more sensitive to LL faults compared to the pickup setting of $50P_{UR}$, an important feature considering subsequent faults, which will be discussed in an upcoming subsection. The $50Q_{UR}$ element does have a 1.5 cycle delay, as recommended by the manufacturer, to avoid tripping on transient negative-sequence current when picking up balanced load. Also, note in Table I the $LL_{DS_DLM_Device}$ value is defined as the LL fault phase current value and must be multiplied by $\sqrt{3}$ to convert to I_Q prior to setting $50Q_{UR}$.

It is important to mention that I_Q is largest for LL faults at a given location. Because of the zero-sequence network involvement in double-line-to-ground faults and 1LG faults, I_Q will be lower for these faults compared to LL faults, so setting $50Q_{UR}$ as shown in Table I ensures security against overreach. Lastly, the $50Q_{OR}$ element in Table I is set in the same manner as $51Q$ to provide additional sensitivity for the overreaching LL fault detection.

B. DLM Breaker-Coordination Delay

As indicated in Fig. 5b, the 50_{OR} elements have a breaker-coordinated, definite-time-delay, $50D_{OR}$. The delay value is 6 cycles for the middle DLM device (R1) and 12 cycles for the furthest upstream DLM device (FR) when it reaches beyond the middle device's instantaneous 50_{UR} elements (presently, Avista doesn't have any circuits with more than three DLM devices in series). The 6 cycle breaker coordination time is derived from the following:

- Rated recloser trip time, incl. arcing (3 cyc \pm 0.5 cyc)
- Full-cycle cosine filter attenuation time (1.25 cyc)
- Safety margin/Inrush blocking buffer (1.25 cyc)

Fig. 7 depicts a recloser's operating time and familiar relay filter attenuation. The B-phase current is plotted for what was a 3.5 kA BC fault. The $51Q$ element (not shown) timed out and issued the trip command (TRIP3P digital). The breaker opens and the unfiltered B-phase current (green trace) ceases to flow at its zero-crossing 55 ms following the trip. Thereafter, the full-cycle cosine filtered current (blue) takes one cycle to completely attenuate and the magnitude (red), computed using quadrature filter samples, fully attenuates 0.25 cycles later. Because the relay processes its protection functions at a rate of four samples per cycle, the $50P1$ element deasserts shortly after the current magnitude drops below the $50P1P$ level and 75 ms following the initial trip (orange marker). It is worth noting that of the handful of relay event records checked for total operation

time (i.e. time from trip initiate to 50 element deassertion), the record in Fig. 7 was the longest observed, with the shortest at 1.75 cycles and most around 3 cycles in length.

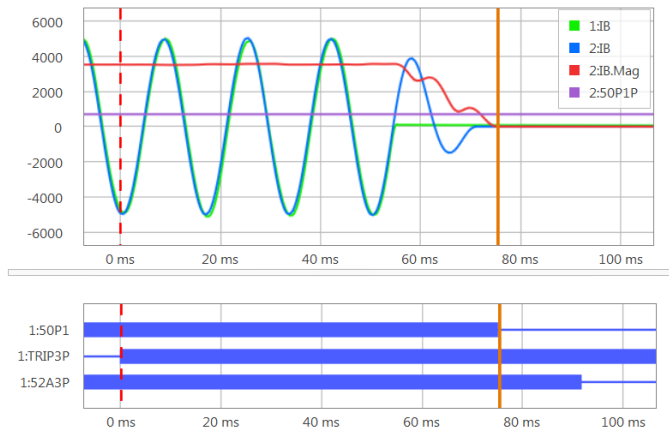

Fig. 7. 3.5 kA BC Fault with B-Phase Current's Unfiltered (Green), Filtered (Blue), and Magnitude (Red) Signals Plotted, and the 50P1P Setting (Violet)

The aforementioned inrush blocking buffer of 1.25 cycles provides sufficient time for the inrush security logic to stabilize, which will be discussed further in an upcoming subsection.

Since operating speed is the primary concern for DLM operations, a feeder relay breaker coordination delay of 12 cycles can be reduced under the proper circumstances. If the minimum fault sensitivity the feeder DLM relay needs to provide is confirmed to be larger than the pickup of the instantaneous 50_{UR} elements of the immediate downstream DLM device, the breaker-coordination delay for the feeder relay can be lowered to 6 cycles, as demonstrated in Fig. 8a. In the figure, FR's 50_{OR} elements provide sufficient sensitivity for its longest lateral (FR EOL) while being set greater than recloser R1's 50_{UR} elements, ensuring that FR's overreaching zone stops short of R1's instantaneous zone and permitting a single breaker-coordination delay of 6 cycles for FR.

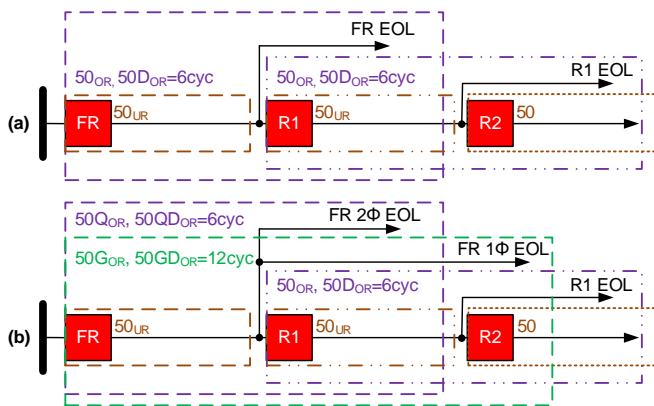

Fig. 8. Lowering the Feeder Relay's (FR) Overreaching Element Breaker-Coordination Delay, 50_{DOR} , when Circuit Layout Allows, for All Elements (a) or Individual Elements (b)

Additionally, because the Phase, Ground, and I_Q 50_{OR} elements all have independent timers, the delays can be further tuned, if circuit conditions allow. Fig. 8b demonstrates a situation where FR's longest two-phase lateral, FR 2 Φ EOL, is such that sufficient protection via FR's 50_{QOR} stops short of

R1's 50_{UR} reach, but the longest single-phase lateral protected by FR, FR 1 Φ EOL, is such that FR's 50_{GOR} reaches past the 50_{GUR} of R1. In such a case, 50_{QDOR} for FR can be set at 6 cycles while 50_{GDOR} for FR would be left at 12 cycles.

C. Custom Sequencing Logic for Base DLM Operation

Relay sequencing applies to distribution protection schemes which use 50 or fast-curve 51 elements exclusively for initial recloser shot(s) (e.g. SH0) and then switch to slow-curve 51 elements for subsequent shot(s) (e.g. SH1, SH2), such as in a hybrid fuse-saving/fuse-tripping scheme. Sequencing logic will automatically advance the reclosing shot counter in an upstream device that sees specified protection elements assert and deassert without resulting in a trip signal, an indication that a downstream device operated in response to a fault. In this way, when the downstream device recloses and switches to slower elements, the upstream device doesn't trip and reclose, but coordinates via its slow-curve elements when supervising the fast elements with the shot counter.

As an example, if FR and R1 in Fig. 9 are both operating in Base DLM (Fig. 1) and a permanent fault occurs on the trunk downstream of R1 (F_1), then R1 would trip instantaneously on a 50 element and the breaker would clear before 50_{DOR} timed out for FR. When R1 recloses back into the fault, R1 disables its 50 elements and starts timing on a 51 element. Without applying sequencing, FR would trip on its 50_{OR} element 6 cycles after R1 recloses, and then FR would reclose and switch to its 51 elements and coordinate with R1's 51 element. Sequencing logic prevents the unnecessary upstream trip by FR.

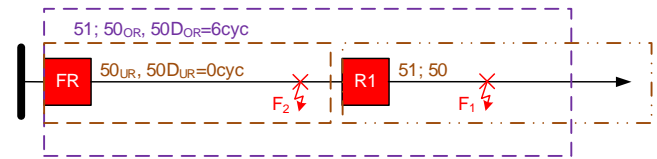

Fig. 9. An Initial Fault (F_1) Results in a Subsequent, Temporary Upstream Fault (F_2)

The relay's sequencing logic setting specifies the elements used to identify a downstream fault (e.g. 51 pickup). When those elements are asserted for at least 1.5 cycles, the sequencing logic advances the shot counter when the sequencing logic setting deasserts. The shot count is used to supervise the 50 elements in the tripping equation. Avista's initial deployment of the DLM settings made use of the relay's sequencing logic but later moved to a custom sequencing logic solution after considering the possibility of subsequent, temporary upstream faults, something Avista has witnessed numerous times.

One example of a subsequent fault occurring is when experiencing a fault downstream of a recloser (F_1 in Fig. 9), which the recloser clears, and shortly thereafter (< 1 s) a subsequent fault occurs upstream (F_2). Often the initial and subsequent faults are line-to-line, and the working explanation is when the phase fault currents flow in opposite directions in adjacent conductors, the resulting magnetic forces cause the conductors to push apart. Once the fault is cleared and the

forces removed, the conductors start to swing upstream of the open recloser and can result in a line-slapping fault.

Because these slapping faults tend to be temporary in nature, system reliability can be improved by allowing the relay to go through the full trip and reclose cycle for the subsequent, slapping fault. However, the relay sequencing logic wouldn't allow the relay to reclose because it advances the shot counter in the reclosing (79) logic (e.g. SH0 to SH1) when the initial fault (F_1) occurs. While in Base DLM, if the relay trips in response to a subsequent fault (F_2) with the shot counter at anything greater than SH0, it automatically goes to lockout.

Avista recognized this limitation of the relay's sequencing logic to subsequent, temporary faults. With the user-customizable logic available in the relay, Avista built its own sequencing logic, as shown in Fig. 10a. The overreaching element blocking bit, OR_{BLK} , asserts when any of the overreaching 50 elements ($50P_{OR}$, $50G_{OR}$, $50Q_{OR}$) deassert while a trip hasn't been issued, which occurs when a downstream breaker-based device clears a fault. Another possible situation is a small fuse at the end of a lateral clearing a fault before the overreaching timer, $50D_{OR}$, expires (e.g. a fault at FR EOL in Fig. 6). The OR_{BLK} logic won't engage when the relay does issue a trip because the trip duration dropout timer ensures TRIP is asserted when the overreaching elements deassert in response to their breaker clearing the fault.

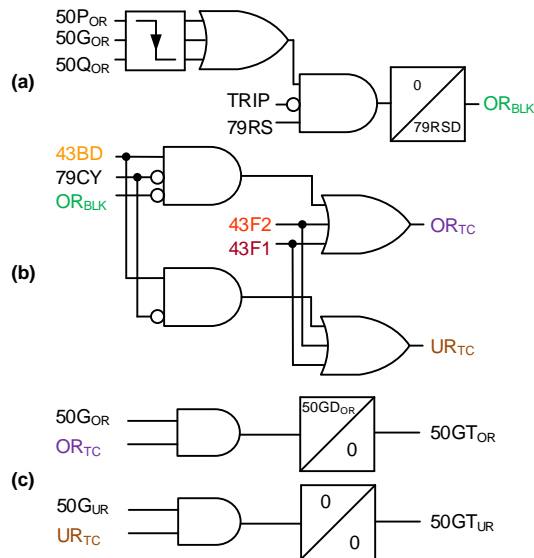

Fig. 10. Custom Sequencing Logic (a) Overreaching (OR_{TC}) & Underreaching (UR_{TC}) Torque Control Logic (b) and Overreaching ($50GT_{OR}$) & Underreaching ($50GT_{UR}$) Ground Overcurrent Tripping Elements. The Phase and Negative-Sequence Overcurrent Tripping Elements are Similar (c)

The falling edge detector in Fig. 10a ensures the blocking logic doesn't remain asserted, and a dropout time equal to the relay's recloser reset delay, $79RSD$ – set to 2 minutes, ensures that OR_{BLK} stays asserted until the downstream device has reset itself (assuming a temporary downstream fault). The relay has three recloser logic states, the reset state ($79RS$), cycling state ($79CY$), and lockout state ($79LO$), and the use of $79RS$ in Fig. 10a ensures that OR_{BLK} doesn't engage on inrush currents when the relay automatically recloses (i.e. $79CY$ state) or following a manual close, where the relay remains in the $79LO$

state for 30 s following the manual close (as specified by the $79RSLD$ delay setting) before switching to the $79RS$ state. Note that the 50_{OR} elements in Fig. 10a are pure, level-detector 50 elements uninhibited by the inrush security supervising logic, which is discussed in the next subsection.

The overreaching and underreaching element torque control logic (OR_{TC} and UR_{TC} , respectively) is shown in Fig. 10b. The Base DLM, Fire 2-Shot, and Fire 1-Shot switches ($43BD$, $43F2$, and $43F1$, respectively, in Fig. 10b), are programmed in the customizable relay logic to be mutually exclusive and can be set either locally, via the relay's front panel pushbuttons, or remotely, via DNP binary outputs, and control which DLM the relay operates in. When operating in Base DLM ($43BD=1$), the overreaching elements are only allowed to operate if the relay isn't in the $79CY$ state (when only 51 elements are active) and OR_{BLK} is deasserted. Conversely, the underreaching elements are enabled as long as the relay isn't in the $79CY$ state, which allows them to respond to a subsequent fault (e.g. F_2 in Fig. 9) and reclose, even if the overreaching elements are blocked via OR_{BLK} .

The use of $79CY$ in Fig. 10b also enables the 50 elements following a manual close while the relay is in the $79LO$ state until it resets. Fig. 10b indicates that the overreaching and underreaching elements are always enabled while in Fire 2-Shot ($43F2=1$) or Fire 1-Shot ($43F1=1$) where sequencing isn't necessary. Lastly, Fig. 10c shows how the torque control logic is routed to the overreaching ground element ahead of its breaker-coordination delay, $50GD_{OR}$, and also routed to the underreaching ground element. Binary points $50GT_{OR}$ and $50GT_{UR}$ are routed to the relay's tripping logic. The $50P$ and $50Q$ tripping element logic is similar to Fig. 10c.

D. Inrush Security

Anytime a breaker energizes devices that can store residual magnetism there is the potential for magnetizing inrush currents, the severity of which depends on the residual magnetism relative to the system voltage "point-on-wave" at the breaker closing instant and the system strength behind the breaker [9]. Inrush currents can reach peak levels as high as 10 times the rated current of the connected kVA but will significantly subside within the first several cycles. While rich in second-harmonic content that results in a substantial reduction to the relay's filtered 60 Hz (fundamental) component used by its protective functions, inrush currents are still capable of asserting 50 elements, especially when set for sensitivity.

With DLM operation, the two instances most likely to trigger the 50 elements are: 1) following a manual close, and 2) when reclosing while operating in Fire 2-Shot mode. In both cases, the lower-set, overreaching elements are enabled and most prone to assert on inrush. A reclose while operating in Base DLM is not a concern because the 50 elements are disabled.

Of the relays on the DLM roster, approximately 70% of them have second-harmonic inrush blocking capability, while the remaining 30% do not. We will discuss the harmonic blocking considerations first and then discuss inrush security for those relays which don't have harmonic blocking.

1) Second-Harmonic Blocking Considerations

Second-harmonic blocking works by extracting the fundamental and 2nd harmonic magnitudes from each of the unfiltered phase current signals and calculating the percentage of 2nd harmonic component with respect to the fundamental (Fig. 11). If this percentage is above a user-settable threshold (HBL2P) the harmonic-blocking element for that particular phase asserts. The assertion of any of the three phase harmonic elements asserts a harmonic cross-blocking bit (HBL2T).

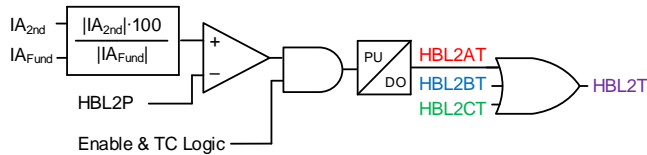

Fig. 11. Second Harmonic Blocking Logic

Avista has been using the harmonic blocking logic in its distribution relays for the last 6 years. The inrush shown in Fig. 12 was captured from a feeder relay when the feeder picked up 40 Apri of load from an adjacent feeder which served some mining facilities. When the tie switch was closed, the large inrush currents caused the relay's 50 elements to immediately assert and trip the breaker. This relay operation was the motivating event for Avista to seek an inrush security solution [8].

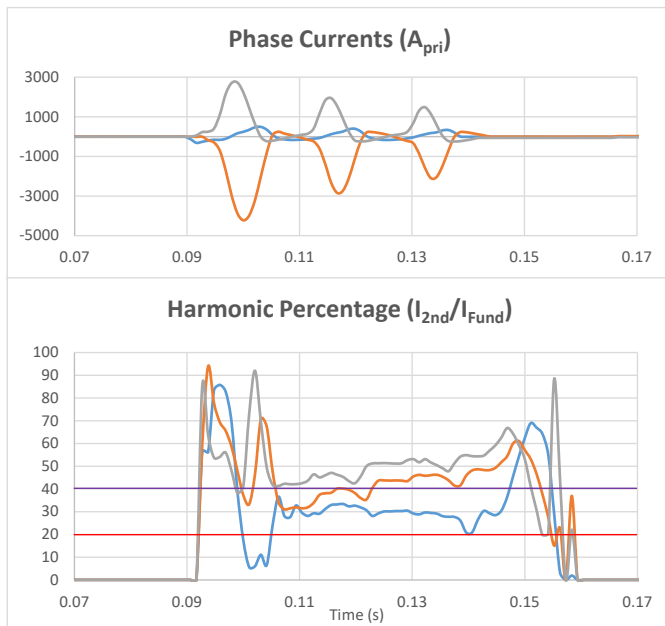

Fig. 12. Inrush Currents (A-Phase: Blue; B-Phase: Orange, C-Phase: Grey) when Picking Up Adjacent Feeder Load and Their Corresponding Harmonic Percentages

To set the harmonic blocking logic, Avista played the waveforms from Fig. 12 back to a relay in the shop, along with a couple of other inrush events, and tuned the HBL2P setting until the inrush blocking was sufficient. Monitoring the HBL2T relay word bit, a HBL2P setting of 40% was selected which provided enough blocking time until the inrush current attenuated below the level of the 50 elements. From Fig. 12, it is clear that the C-phase harmonic percentage (grey) remains above the 40% threshold until the breaker opens, which leaves

HBL2T asserted the entire time, even though the other two phases drop below the threshold. Avista placed the HBL2T blocking bit into the 50 elements' torque control equations to supervise them during inrush conditions.

When considering DLM protection, Avista made several changes to the way the relay implemented inrush security. First, the relay needed to move to a per-phase inrush blocking scheme, in order to speed up the relay response when reclosing into a fault while in Fire 2-Shot mode. Fig. 13 depicts a relay reclosing into a C-phase fault, with inrush current appearing on phases A and B. It is clear from the harmonic percentages that a cross-blocking inrush scheme (blocking with HBL2T) results in a significant delay to relay tripping. With a blocking percentage of 40%, the harmonic content in A-phase (blue) and B-phase (orange) would prevent the relay from responding to the fault until both phases drop below 40%, at least 500ms after fault inception. However, the harmonic percentage of the fault current in C-phase drops below the 40% threshold within 12ms of the breaker closing (the transient assertion is an unavoidable byproduct of the 2nd harmonic filter [10]), so if the C-phase 50 element were supervised with just the C-phase harmonic blocking component (HBL2CT) the relay could respond significantly faster.

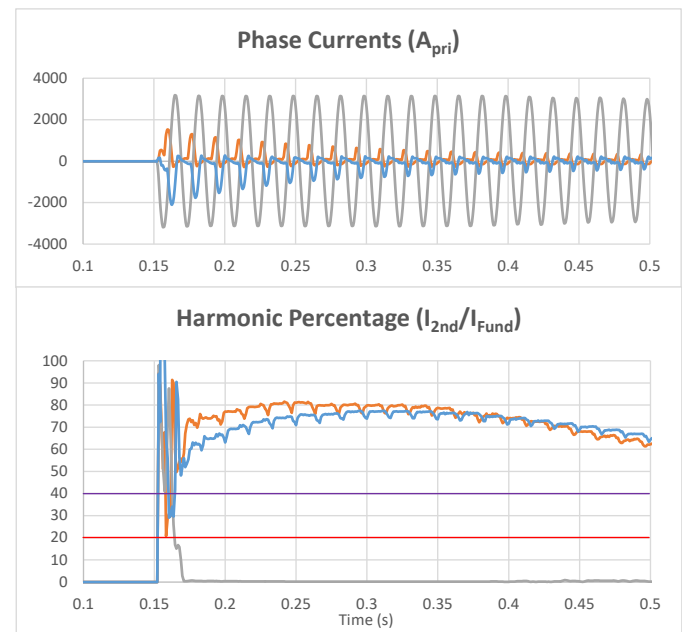

Fig. 13. Feeder Relay Reclosing Into a C-Phase (Grey) Fault with Harmonic-Rich Inrush Current on A-Phase (Blue) and B-Phase (Orange)

The per-phase harmonic blocking implementation is shown in Fig. 14 for the overreaching 50 elements (the underreaching 50 element logic is similar). Note that cross-blocking is necessary for the 50G and 50Q elements as there are no blocking elements which monitor the 2nd harmonic content of the ground and negative-sequence currents.

A second change Avista made to the inrush security for DLM operations was to lower the harmonic pickup setting, HBL2P. Returning to Fig. 12, A- and B-phase currents both are below the 40% harmonic threshold and, thus, not blocked. The A-phase current is not a concern in this particular event with

the filtered current magnitude maxing out at 230 Apr (50P for a feeder is often set higher than that), but the B-phase current's harmonic percentage dips below the 40% threshold for one cycle around the 0.11 s mark with the B-phase filtered current magnitude in this period at 1500 Apr, which is likely to operate under the newly configured per-phase harmonic blocking.

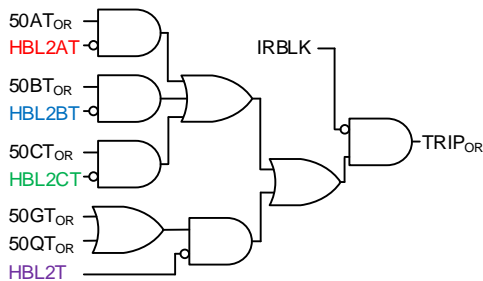

Fig. 14. Custom Overreaching Overcurrent Tripping Element Logic. The Underreaching Overcurrent Tripping Element Logic is Similar

To select the new blocking percentage, Avista analyzed feeder relay and recloser records from across the system for inrush events, fault events, and steady-state operation to find the optimal blocking value. A HBL2P setting of 20% provided sufficient security while also leaving some sensitivity for the ground and negative-sequence elements. Because 50G and 50Q are blocked with the cross-blocking bit (HBL2T in Fig. 14), if the harmonic percentage is set too low, they will both be inoperable for a significant period of time when reclosing into a fault if there is any amount of harmonic content in the unfaulted phase(s). However, even if the 50G and 50Q elements are blocked for an extended period of time, the per-phase blocking of the lower-set, overreaching phase elements allows for significant sensitivity to 1LG and LL faults. From the fault records analyzed, a HBL2P setting of 20% will typically allow the relay to unblock for a fault within 0.5-1 cycle.

Even with the lowered harmonic blocking level of 20%, transient “holes” in the harmonic percentage can leave the relay briefly unprotected from inrush. From Fig. 12, the A-phase harmonic percentage drops below the 20% level around the 0.1 s mark for approximately 5 ms. These holes are most likely to occur within the first cycle of line energization, where it appears that the phases impact each other due to the magnetic interaction within three-phase, three-legged transformers on the feeder [11]. From Fig. 12, the A-phase inrush current begins with a negatively-increasing amplitude, but when C-phase is energized, the A-phase current changes to a positively-increasing amplitude. When B-phase is energized and experiences a significant positive increase in current, the C-phase current simultaneously experiences a large negative increase in current.

These interactions between the phases within the first cycle following energization that result in the inrush current briefly flattening or its slope changing direction cause a transient attenuation in the magnitude of 120 Hz filter and results in the hole captured in the A-phase harmonic percentage of Fig. 12. A separate inrush event Avista analyzed had a more severe hole in the harmonic percentage, lasting just under 1 cycle. To guard against these holes, a separate blocking inrush blocking logic is

added (IRBLK in Fig. 14) which asserts for 1.25 cycles following line energization. This blocking delay should be sufficient to cover all holes in the harmonic blocking logic when considering the inrush current waveforms appear to “stabilize” and repeat themselves after the first cycle and the 120 Hz filter is fully “charged” after one 60 Hz cycle. The inrush blocking logic that defines IRBLK will be discussed shortly. Note that Avista sets the pickup and dropout delay included in the harmonic blocking logic to zero (Fig. 11).

One final change made in the implementation of the DLM inrush security was to move the harmonic blocking action out of the 50 elements' torque control equations. The benefit of this change is a harmonic blocking assertion doesn't “stall” the breaker-coordination timer of the overreaching 50 elements (e.g. 50GD_{OR} in Fig. 10c). As pointed out in Fig. 13, the response of the 120 Hz filter to any change in the current will result in a temporary assertion of the harmonic blocking element, even with pure 60 Hz fault current. Further, if any CT saturation occurs during a fault, the assertion of the harmonic blocking element is prone to extend during the saturated period. By supervising the timed 50 element output (e.g. 50GT_{OR} in Fig. 14) with the harmonic blocking logic it helps to speed up tripping and maintain coordination with the upstream DLM protection.

2) Inrush Blocking Timer

A significant challenge to overcome in the new DLM scheme was providing inrush security for the relays that didn't have second-harmonic blocking capabilities (~30%) while still maintaining coordination with the harmonic blocking-based ones. The solution that Avista devised is to block the relay for a set period of time following energization of its line section. The blocking time allows the inrush current to subside and drop below the level of the 50 elements.

The first component to this method is to reliably detect line energization situations. Initially, Avista elected to use the assertion of the relay's load current element (50L) to indicate an energized line. The 50L element was chosen over a 52a contact because of the possibility of an upstream device tripping, reclosing, and energizing the feeder or recloser line section while the downstream relay's breaker was still closed.

The 50L element is simply a sensitive 50P element. Given the minimum setting values and the CT ratios Avista uses, the 50L element can detect down to 40 Apr in the feeder relays and 25 Apr in the recloser. The max summer loading information that Avista's Protection group requested from the area engineers were well above these thresholds. However, upon inspection of the minimum summer loading values, it became clear that some of these feeder relays and, especially, reclosers can regularly see load current below the minimum 50L thresholds (see Fig. 4), especially at night. The consequence of this behavior is when a fault occurs while the loading is below the 50L threshold, the inrush blocking timer will engage on an initial fault and block the element, which could result in a miscoordination with an upstream relay's overreaching 50 element. As will be discussed, the inrush-blocking-timer method depends on the timer only engaging for line energization situations.

The fix to the 50L sensitivity issue was to incorporate the 50L element, 52a contact, and source-side voltage together as shown in Fig. 15. When the breaker is closed with source-side voltage present and 50L is deasserted (low load current), the logic is disengaged. Once the breaker opens, then the blocking logic, IRBLK, picks up. When the breaker closes, the presence of inrush current will assert 50L, the input to the blocking timer will deassert, and the dropout timer will extend the IRBLK assertion for the amount of time set by IB_{DLY} .

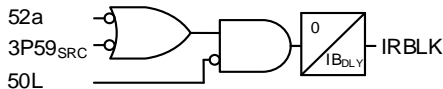

Fig. 15. Custom Inrush Blocking Timer Logic

For the case of a closed breaker and an upstream device deenergizing the line section, a source-side, three-phase overvoltage element, $3P59_{SRC}$, will deassert (Avista only does three-phase tripping on its distribution and transmission systems) and engage the blocking logic. Once the upstream breaker closes, the presence of inrush current at the downstream device will again assert 50L and start the blocking timer.

With reliable detection of line energization in place, the other component to the inrush blocking timer method is to determine the inrush blocking time (IB_{DLY}). The concern with setting a blocking timer is when energizing a line into a fault and the relay's inrush blocking timer disrupts the breaker-coordination delay (6 cycles) with the DLM device upstream of it and both DLM devices trip. The situation that must be avoided is both devices tripping to lockout.

Recall the two instances of inrush most likely to assert a DLM 50 element, and thus most critical to secure against, are following a manual close and when reclosing while operating in Fire 2-Shot mode. In either of these cases, if there is a fault present on the line and the relay trips, it will go to lockout. As mentioned previously, following a manual close the relay will remain in the lockout state (79LO) for 30 s, as established by the 79RSLD delay setting. Any tripping action occurring during this 30 s period immediately locks the breaker out. When reclosing into a fault while operating in Fire 2-Shot the relay trips and, by definition, goes into lockout.

Another important observation is any amount of inrush blocking time could result in a coordination issue. Section V Subsection B mentioned the DLM breaker coordination time of 6 cycles has a 0.75 cycle safety margin built-in, but that isn't sufficient blocking time for inrush current. From the inrush event records Avista has reviewed, the 50 elements asserted for up to 3 cycles in response to inrush. A 3 cycle inrush blocking time will likely create a coordination issue with the upstream device and still may not provide sufficient blocking time for all cases of inrush or lower-set overreaching 50 elements. Thus, the inrush blocking time should be set as conservatively as possible.

Taking all these observations into account, Avista decided to set the inrush blocking timer (IB_{DLY} in Fig. 15) to 6 cycles. If the relay closes into a fault, the 6 cycle delay guarantees both the closing relay and upstream relay will trip, but the closing relay will trip to lockout while the upstream device will reclose.

The one exception is when manually closing an inrush-blocking-timer-based relay operating in Fire 1-Shot. In this case, the upstream device will need to be moved down to Fire 2-Shot or Base DLM operation to provide the reclosing action if the closing relay does close into a fault. The inrush-blocking-timer-based reclosers are programmed with a DNP binary input that provides indication to the operators when they are attempting to close one of these specific reclosers so they can take the appropriate action with the upstream device.

As mentioned, the inrush records Avista reviewed showed 50 element assertion times of up to 3 cycles following line energization, so the 6 cycle blocking time provides sufficient inrush blocking time plus includes a 3 cycle margin if the inrush happens to be more severe. As with the harmonic blocking bits, the inrush blocking bit (IRBLK in Fig. 15) is used to block the breaker-coordinated, definite-time 50 elements' outputs. For example, in Fig. 14, IRBLK is used in place of the four harmonic blocking bits, which are unavailable to the relays under consideration.

The DLM feeder relays are prone to larger inrush currents than the reclosers (more connected kVA; smaller source impedance) and can still have low-set overreaching overcurrent elements, so the DLM feeder relays are programmed with two separate inrush blocking timers as shown in Table II (where "HB" refers to harmonic blocking).

TABLE II
DLM INRUSH BLOCKING DELAY TIMER VALUES

Elements	Non-HB Feeder Relay	Non-HB Recloser	HB Relay/Recloser
50_{UR}	$IB_{DLY_UR} = 6 \text{ cyc}$	$IB_{DLY} = 6 \text{ cyc}$	$IB_{DLY_HB} = 1.25 \text{ cyc}$
50_{OR}	$IB_{DLY_OR} = 9 \text{ cyc}$		

From Table II, the feeder relay's higher-set, instantaneous underreaching elements are blocked for 6 cycles following a line energization, while the lower-set, breaker-coordinated overreaching elements are set with a 9 cycle delay to provide more time for the inrush current to attenuate. When examining different feeder inrush records, there was a beneficial reduction in the inrush current occurring between cycles 6 and 9 following energization, while only incremental attenuation occurred between cycles 9 and 12. Note that if a DLM feeder relay has a 12 cycle breaker-coordination delay for its overreaching 50 elements (e.g. Fig. 6), the inrush blocking time is effectively 12 cycles via the coordination delay. Table II indicates that the DLM reclosers block both their under- and overreaching 50 elements with a 6 cycle inrush blocking delay. Lastly, as previously mentioned, the harmonic-blocking-based relays utilize a 1.25 cycle inrush blocking delay.

E. Future Considerations

Avista is considering several additions to their DLM protection operations. First, the latest generation reclosing relay Avista uses is capable of high-impedance fault (HIF) detection [3]. Avista plans to add this functionality, when appropriate, to provide additional protection year-round, but especially during fire season. One stipulation of the HIF algorithm is it requires the load current not drop below 25 Apr (CTR=500) for more

than four hours or it will retune the level detector it uses to identify HIF activity (24 hour tuning period). As mentioned, Avista has some feeders and reclosers that have low nighttime loading (e.g Fig. 4) and would not be eligible for the HIF algorithm.

Another consideration for future enhancements to the DLM scheme is the use of fault transmitter (FT) and fault repeater (RP) line units to provide fast trip blocking (FTB) capability [12], as shown in Fig. 16. These units clamp onto the conductor via a hot stick and harvest power from the line.

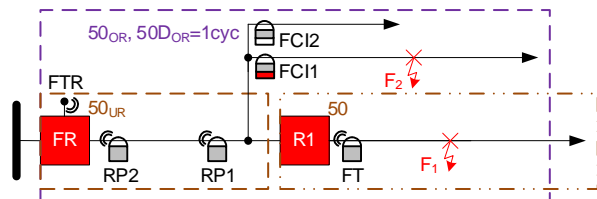

Fig. 16. A Fault Transmitter (FT) and Fault Repeater (RP) Line Units, Along With a Fault Receiver (FTR), Provide Fast Trip Blocking Capability for Faults Beyond Downstream Relays (F_1). Faulted Circuit Indicators (FCI) Aid Patrolling of Long Lateral Faults (F_2)

An FT unit is placed immediately past a downstream recloser (R1) and repeater units are placed at appropriate intervals going upstream. A fault receiver (FTR) unit is placed in the cabinet of the upstream device (FR) and links to the relay through a communication port. With FTB functionality, the upstream device's overreaching 50 element coordination delay can be lowered to 1 cycle, which provides enough delay for the FT and RP signal transmission. The FTB application is limited to situations where the two DLM devices (FR and R1 in Fig. 16) are within 1.5 miles of each other, the maximum, conservative distance supported between the FT and FR units. Clearer line-of-sight applications can span further distances.

Finally, Avista plans to install faulted circuit indicators (FCI) on circuits with long laterals to aid patrolling (e.g. FCI1 indication in response to F_2 in Fig. 16).

VI. CONCLUSION

While electrically-induced fires can pose a severe danger to public and property, electricity is an essential, often vital, resource our societies depend on. While in certain situations, preemptive events, such as Public Safety Power Shutoff, are a necessary course of action, having a tiered operational approach to wildfire resiliency allows for a balance between responding to fire risk and maintaining the essential service electric utilities provide to society.

Avista's improvements to its Dry Land Mode operational procedures seek to achieve that balance by considering circuit-specific fire risks and adjusting system protection accordingly. Using a method that leverages large amounts of publically available weather and fire data along with its existing protection and integration infrastructure, Avista was able to add measured, dynamic wildfire protection to a significant portion of its fire-risk service areas, relatively quickly, and provide the groundwork for the remaining areas to be upgraded over the next several years.

As it pertains to utility-based wildfire protection, there is no silver bullet. Utilities should continue to take a multi-faceted approach to their preventative maintenance and operational procedures in response to wildfire risks, and continue to collaborate and share their ideas and experiences within our industry.

VII. ACKNOWLEDGEMENTS

The authors wish to thank all the involved groups and individuals at Avista for their contributions to make the work presented in this paper possible. Avista's Wildfire Resiliency team, especially David James and Douglas Forkner, contributed to the creation of the dynamic Dry Land Mode operating concept and spearheaded the efforts in producing the Fire Risk Potential calculations. Avista's Innovation Lab team, especially Ben Shannon and Kenneth Wilhelm, provided power system simulation and hardware-in-the-loop support to help test and troubleshoot the proposed scheme. Avista's area engineers provided the distribution circuit information required to properly set the relays. Distribution Operations, especially Jill Ham, provided valuable insights that helped improve the relay's DLM behavior. Avista's SCADA group, especially Lamont Miles, provided the upgrades to the DMS system to support the dynamic DLM relay operations. Shane Pacini oversaw the large upgrade efforts of the 2021 DLM relay roster. Avista's Relay Shop, as always, provided excellent work in handling the DLM relay upgrades and commissioning activities. Last, but certainly not least, Avista's Protection group helped with reviewing the relay DLM settings templates, creating relay settings files, and handling other protection tasks, allowing the authors to more fully focus on these wildfire resiliency efforts.

VIII. REFERENCES

- [1] B. Smith, D. James, "Wildfire Mitigation Using Satellite Analytics: Leading IOU Real World Implementation," *T&D World*, April 28, 2021. [Video recording]. Available: <https://events.tdworld.com/tdworld2021/session/479273/webinar-wildfire-mitigation-using-satellite-analytics-leading-iou-real-world-implementation>, Accessed on: May 5, 2021.
- [2] S. Augustine, B. Kirkpatrick, T. Tran, "Implementing Asset Incipient Failure Detection Technology to Mitigate Wildfires at Southern California Edison," *T&D World*, April 6, 2021. [Video recording]. Available: <https://events.tdworld.com/tdworld2021/session/439518/webinar-implementing-asset-incipient-failure-detection-technology-to-mitigate-wildfires-at-southern-california-edison>, Accessed on: April 6, 2021.
- [3] M. Kistler, F. Heleniak, T. Varshney, "Practical Experience With High-Impedance Fault Detection in Distribution Systems," proceedings of the 46th Annual WPRC, October 2019.
- [4] Avista Utilities, Wildfire Resiliency Plan, <https://www.myavista.com/-/media/myavista/content-documents/safety/wfreswoaddendum.pdf>
- [5] USDA, Wildfire Hazard Potential Map, <https://www.firelab.org/project/wildfire-hazard-potential>
- [6] US Drought Monitor, <https://droughtmonitor.unl.edu/>
- [7] National Interagency Fire Center, <https://www.nifc.gov/fire-information>
- [8] K. Damron, R. Spacek, "Smart Grid – Smarter Protection: Lessons Learned," proceedings of the 42nd Annual WPRC, October 2015.
- [9] D. Taylor, J. Law, B. Johnson, N. Fischer, "Single-Phase Transformer Inrush Current Reduction Using Prefluxing," *IEEE Transactions on Power Delivery*, vol. 27, no. 1, pp. 245, 252, January 2012.

- [10] B. Kasztenny, M. Thompson, D. Taylor, "Time-Domain Elements Optimize the Security and Performance of Transformer Protection," proceedings of the 71st Annual Conference for Protective Relay Engineers, March 2018.
- [11] J. Brunke, K. Fröhlich, "Elimination of Transformer Inrush Currents by Controlled Switching. Theoretical Considerations," *IEEE Transactions on Power Delivery*, vol. 16, no. 2, pp. 276, 280, April 2001.
- [12] E. McCollum, K. Hao, S. Achanta, J. Blair, D. Keckalo, "Low-Cost Fast Bus Tripping Scheme Using High-Speed Wireless Protection Sensors," proceedings of the 45th Annual WPRC, October 2018.

IX. BIOGRAPHIES

Douglas Taylor received his BSEE and MSEE degrees from the University of Idaho in 2007 and 2009. He joined Schweitzer Engineering Laboratories, Inc. in 2009 and worked as a protection engineer and as a research engineer in the Research and Development division. In 2019, Doug joined the System Protection group at Avista Utilities and currently serves as a senior protection engineer. He is a registered professional engineer in the state of Washington. Doug's main interests are power system protection and power system analysis. He holds 3 patents and has authored or helped author 20 technical papers in the area of power system protection.

Kevin Damron received his BS in electrical engineering from the University of Kentucky in 2001 and a 'Power Systems Protection and Relaying' certificate from the University of Idaho in 2009. Kevin has broad experience in the field of power system operations, maintenance, and protection. Upon graduating, he joined Schweitzer Engineering Laboratories, Inc. as a power engineer in the research and development division. Prior to joining Avista Utilities in 2010, he was employed by Eta Engineering Consultants, PSC providing engineering and consulting services. Kevin went on to complete his Master of Engineering in Transmission and Distribution Engineering degree from Gonzaga University in 2020. Kevin is a registered professional engineer in Washington State and is an IEEE Senior Member.