

OPTIMIZATION OF DISTANCE PROTECTION PERFORMANCE USED IN WIND FARMS' COLLECTION NETWORKS

Alexander Tsylin¹, Zoran Gajić², Mike Kockott³

¹Ørsted, Denmark

²Hitachi Energy, Sweden, ³Hitachi Energy, USA

¹alets@orsted.com

²zoran.gajic@hitachienergy.com

³mike.kockott@hitachienergy.com

Keywords: COLLECTION NETWORK, DIRECTIONAL ELEMENT, DISTANCE PROTECTION, WIND WARM, WIND POWER.

Abstract

Distance protection provides fast fault clearance time, improved sensitivity and selectivity. Nowadays its applications include collection networks of Wind Farms (WF) which normally have resistive grounding, where distance protection is used as a main protection for the array cable systems. However, distance protection is not optimized for such applications and practical experience shows that it might maloperate during earth faults due to incorrect determination of fault direction. The paper provides a solution for this problem which is to utilize non-directional ground distance protection zones with additional supervision logic containing directional check based on directional earth fault protection functionality supplemented by other criteria. Recommended typical settings for the utilized functional elements and the overall performance of the optimized ground distance protection's logic have been proven via software simulations in DlgSILENT PowerFactory and the results have been verified by testing of a commercial distance protection relay in a laboratory environment. The proposed optimized logic for ground distance protection used in WF collection networks can be implemented to increase its selectivity and stability during earth faults. This in turn will improve reliability and availability of power generation which is high priority for WF developers, operators, and owners.

1 Introduction

Distance protection provides fast fault clearance time, improved sensitivity and selectivity, and is traditionally used for transmission-class High Voltage (HV) systems. Widespread use of numerical Intelligent Electronic Devices (IEDs) has made it possible to achieve all the benefits of distance protection application for systems of a lower voltage class such as distribution and sub-transmission Medium Voltage (MV) systems. These applications nowadays include collection networks of Wind Farms (WF) which normally have resistive grounding via a Neutral Grounding Resistor (NGR), where stepped distance protection is used as a main protection for the array cable systems. However, distance protection is not optimized for such applications as it is primarily designed for protection of HV overhead lines in a solidly grounded power system where current will lag voltage in the faulty phase or loop.

Theoretical analysis as well as practical experience show that a combination of several factors such as large capacitive currents, current-limiting impedance in the system neutral point, high Wind Turbine Generators (WTGs) infeed, etc. during a single line-to-ground fault (earth fault) makes the distance protection used in MV array system of a WF prone to maloperation due to incorrect determination of a fault direction [1]. The issue is mainly applicable to the faulty array cable's protection, however, it might also affect healthy cables' distance protection response. Such a maloperation might lead to adverse

consequences such as longer fault clearance time or undetected faults, and thereby even excessive damage to the primary equipment and revenue loss.

Proper operation of the distance protection in MV array system of a WF can be ensured by taking special measures intended to optimize the protection's response during earth faults which are described in the paper.

2 Problem description

2.1. Distance protection in WF collection networks

A typical Single Line Diagram (SLD) of an offshore WF is presented in Fig. 1.

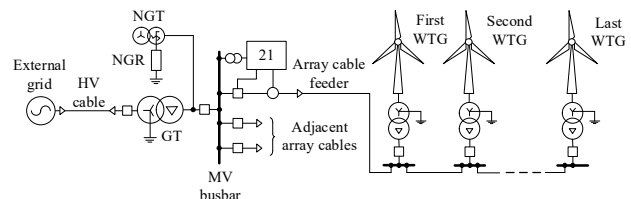

Fig. 1 Typical SLD of an offshore wind farm

An offshore WF is connected via a Grid Transformer (GT) and a long HV submarine cable to an onshore HV transmission grid. In case of an onshore WF GT is connected directly to the HV grid. It shall be noted that analysis and findings presented in this paper are applicable to both offshore and onshore WFs.

The MV system of a WF, which typically operates at 33 kV or 66 kV level is grounded via a Neutral Grounding Transformer (NGT) and NGR – refer to Fig. 1. The earth fault current on the MV side is then limited to a certain value (typically in the range from 600 A to 2500 A primary) and is dominantly resistive in nature due to the NGR and NGT sizing. However, installation sites do exist where NGR is completely omitted and only the NGT is used. In such installations the earth fault current component through the grounding impedance is inductive in nature, hence, the analysis and conclusions which are described in the next sections are not directly applicable to such systems and alternative solutions shall be used if required, however, they are out of scope of this paper.

Array cable feeders outgoing from the WF MV bus are used to collect power produced by several WTGs and are individually equipped with distance protection IED (21), as shown in Fig. 1. Such array cable feeders can be up to 40 km long especially when 66 kV voltage level is used. When an earth fault occurs in one of the array cable feeders voltage in the faulty phase will drop almost to zero and all distance protections both on the faulty but also on all healthy feeders will measure impedances close to zero (i.e. close to an origin of an operating characteristic). At the same time quite large capacitive earth fault current contribution from parallel connected healthy array cable feeders will be present. This capacitive earth fault current component from each healthy feeder varies but in extreme cases it can be up to 100 A primary per 33 kV feeder and even up to 400 A primary per 66 kV feeder.

The distance protection IED installed in the faulty feeder will measure the faulty phase current (I_{L1}) which is equal to the vector sum of the capacitive earth fault current component from healthy and faulty feeders ($I_{\Sigma cap}$ and I_{Fcap} respectively), the resistive current component from the NGR/NGT combination (I_R) and the active/reactive power export current component from the WTGs (I_{WTG}). It can be shown [1] that the faulty phase current under certain conditions may lead (i.e. not lag as typically expected) the faulty phase voltage – refer to Fig. 2a, where $3I_0$ – zero sequence current, U_0 – zero sequence voltage, U_1 – polarizing voltage used by the ground distance protection directional element. Consequently, the impedance measured by the distance protection in the faulty phase and its locus of the operating point might actually reside in the fourth impedance quadrant as shown in Fig. 2b. This might cause a conventional ground distance directional element not to declare this as a forward fault at all. Consequently, for such installations additional measures shall be taken to ensure proper behavior of the ground distance directional element for the faulty feeder.

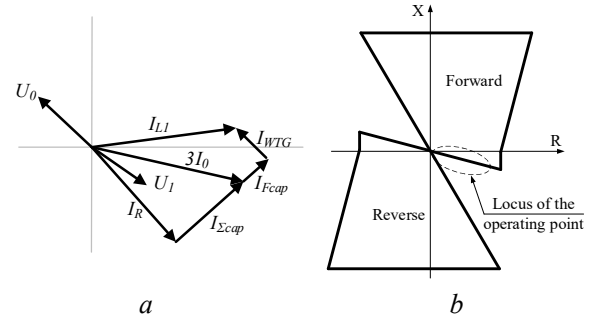

Fig. 2 Array cable exposed to an earth fault
(a) phasor diagram at the distance protection location,
(b) potential locus of the operating point in the 4th quadrant

As the MV bus voltage level in WFs is increasing (e.g. from 33 kV to 66 kV) the capacitive earth fault current contribution from healthy array cable feeders is also becoming much larger (e.g. up to 400 A primary per feeder at 66 kV depending on the length of the cable feeder sections). Such high earth fault current level in a healthy feeder during an earth fault somewhere else in the MV system might cause problems for distance protection which is installed on the healthy feeder. Namely, when this capacitive earth fault current may have approximately the same order of magnitude as a phase load current supplied by WTGs or be even higher than the load current depending on the actual wind conditions. If during such operating scenario zero sequence-based directional check within the distance protection has been chosen for phase-to-ground measuring loops, then the distance protection may declare such reverse fault to be in forward direction and consequently it can maloperate.

2.2. Directional earth fault protection in WF collection networks

Directional earth fault protection (67N) can be used in MV collection networks of WFs and in some cases its directional elements can provide more stable determination of a fault direction in comparison to the ground distance protection directional elements [1]. Analysis of the 67N function operation during earth faults in a MV collection network can be done using its zero sequence equivalent circuit.

It shall be noted that the WF MV system's zero sequence circuit is completely independent from the WTG low voltage side due to the Dy connection of the WTG power transformers and also from the HV system due to the Yd connection of the GT. Based on earth fault theory given in references [2], [3] a simplified zero sequence equivalent circuit, as shown in Fig. 3, can be drawn for the WF MV system for an earth fault in the array cable feeder 1. When an earth fault occurs (i.e. when the switch at the fault location closes in Fig. 3), the zero sequence voltage source $U_0 = -U_{Ph-Gnd}$ at the fault location will energize the distributed capacitances C_{F1} , $C_{F1'}$, C_{F2} and C_{F3} in all feeders connected to the MV busbar as well as the grounding impedance which is dominantly resistive in WF

installations. The current I_{N_F1} flowing through the faulty feeder equipped with directional earth fault protection 67N-F1 equals the sum of the resistive current component I_R which flows towards the grounding equipment and current components I_{N_F2} and I_{N_F3} from all parallel connected healthy array feeders which are of capacitive nature. The capacitive current component I_{CAP_F1} from the faulty array cable feeder will flow through the capacitances C_{F1} and $C_{F1''}$ of the cable itself and is not shown in Fig. 3 as it is not measured by any IED. Note also that I_{N_F1} current will flow in the opposite direction from the set forward direction of the 67N-F1 relay (i.e. towards the bus). All the above-mentioned currents shown in Fig. 3 are divided by three to be properly represented in the zero sequence equivalent circuit.

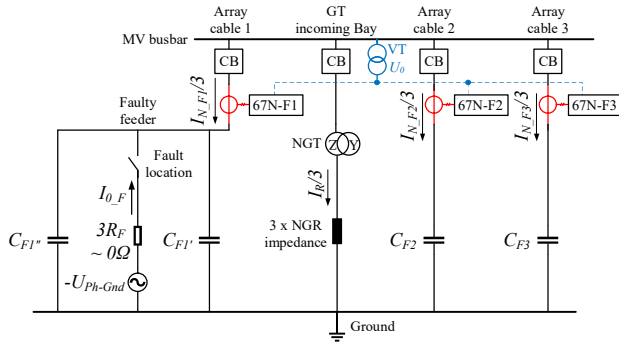

Fig. 3 Simplified zero sequence circuit

The resistive current component I_R will be approximately in phase (or actually will lag with a small angle due to the NGT reactance) with the $3U_0$ voltage. At the same time the capacitive array cable feeders' currents I_{CAP_F1} , I_{N_F2} and I_{N_F3} will lead the $3U_0$ voltage with 90° . Based on that the phasor diagram for the faulty array cable feeder 1 is then given in Fig. 4a.

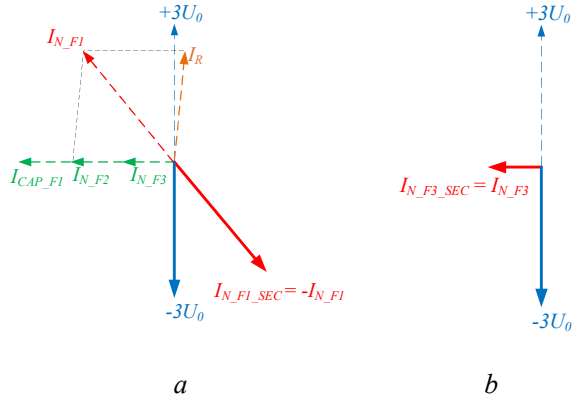

Fig. 4 Phasor diagrams
(a) for the faulty array cable 1,
(b) for the healthy array cable 3

As shown in Fig. 4a the secondary side current $I_{N_F1_SEC}$ which is actually measured by 67N-F1 directional earth fault

protection in the faulty array cable feeder 1 based on the set forward direction will lead the reference voltage $-3U_0$.

The response of the 67N directional earth fault protection in a healthy array cable feeder can be analyzed based on the example of feeder 3. The current I_{N_F3} in the healthy feeder will flow in the same direction as the set forward direction of the 67N-F3 relay (i.e. towards the feeder). The phasor diagram for the healthy array cable feeder 3 is shown in Fig. 4b, where the secondary side current $I_{N_F3_SEC}$ which is actually measured by 67N-F3 directional earth fault protection in the healthy array cable feeder 3 based on the set forward direction will lag the reference voltage $-3U_0$ with 90° . It shall be noted that such a phasor diagram looks very similar to the one drawn for the forward earth fault in a solidly grounded system.

Based on the comparison of the phasor diagrams for healthy and faulty array cable feeders presented in Fig. 4a and Fig. 4b it can be concluded that implementation of the 67N directional earth fault protection based on the $I_N \cdot \cos(\Phi)$ principle shall be best suited for use in WF MV system having resistive grounding as it will provide reliable direction determination of an earth fault for the most challenging operating conditions. The directional characteristic of such 67N protection is shown in Fig. 5, where I_{N_FAULTY} is the earth fault current measured by the 67N protection in a faulty array cable feeder, $I_{N_HEALTHY}$ is the neutral current measured by the 67N protection in a healthy array cable feeder, RCA is the settable relay characteristic which is to be higher than the set pickup value for the directional element to operate.

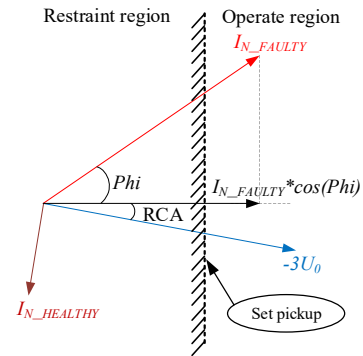

Fig. 5 Directional characteristic of 67N protection

3 Optimized ground distance protection logic

During an earth fault in the WF MV collection system only the 67N earth fault protection installed in the faulty feeder will measure the resistive current component caused by the NGR. This fact can be used to enable additional directional supervision of the ground distance element and optimize its performance during earth faults. Such supervision shall be arranged in a way as described below [4].

First, the logic given in Fig. 6 shall be used to detect a genuine forward earth fault which has occurred in the protected feeder.

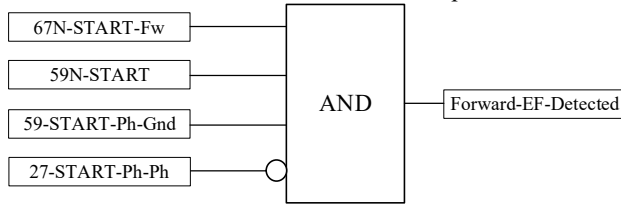

Fig. 6 Logic to detect a forward earth fault

The signals associated with the AND gate shown in Fig. 6 are described in the list below:

1. The “67N-START-Fw” signal shall come from the 67N directional earth fault protection function. The pickup current for this directional element shall be set to 20% of the earth fault current component determined by NGT and NGR sizing. The RCA angle for the 67N function shall be set to 0° (or even to -5° in order to increase the margin towards the capacitive earth fault current in the healthy feeders). This signal shall verify that a resistive earth fault current component from the NGR is measured in the protected array cable feeder.
2. The “59N-START” signal shall come from the 59N residual over-voltage protection function. Its pickup shall be set to 30% of the rated phase-to-ground voltage. This signal shall verify that a residual voltage is detected which typically means that a fault involving ground has occurred.
3. The “59-START-Ph-Gnd” signal shall come from the 59 overvoltage function which measures three phase-to-ground voltages. Its pickup level shall be set to 125% of the rated phase-to-ground voltage. This signal shall verify that a high voltage is detected in at least one of the three phases. During an earth fault in a WF MV system two phase-to-ground voltages will typically exceed this set level.
4. The “27-START-Ph-Ph” signal shall come from the 27 undervoltage function which measures three phase-to-phase voltages. Its pickup level shall be set to 75% of the rated phase-to-phase voltage. This signal shall verify that a low phase-to-phase voltage is not detected among any two phases (note that this binary signal is inverted). Consequently, its pickup prevents operation of this logic in case of a multi-phase faults in the protected MV system.
5. The “Forward-EF-Detected” signal shall indicate that a forward earth fault is detected on this feeder.

Once the forward earth fault is detected in the MV system the logic shown in Fig. 7 shall be used in order to secure proper operation of all forward-looking distance protection zones.

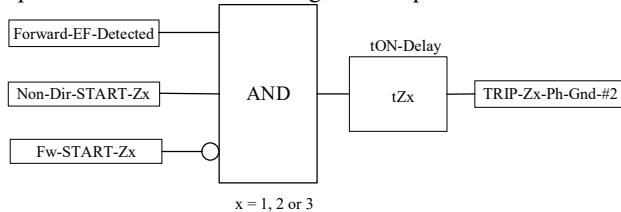

Fig. 7 Additional directional supervision logic for each forward distance protection zone

One AND gate, as shown in Fig. 7, shall be added for each forward-looking distance protection zone. The signals associated with this AND gate are described in the list below:

1. The “Forward-EF-Detected” signal shall indicate that a forward earth fault is detected. See Fig. 6 for more information.
2. The “Non-Dir-START-Zx” signal shall come from distance protection function “Zone x”. This signal indicates that a non-directional start has been given from that zone.
3. The “Fw-START-Zx” signal shall come from distance protection function “Zone x”. This signal indicates that the relevant distance protection zone has started in forward direction. Note that this binary signal is inverted in this logic.
4. The output signal from the AND gate shall be connected to a settable timer. This timer shall be set accordingly (i.e. with the same time delay) as “Zone x”. The only exception would be the Zone 1 which typically has no intentional time delay (i.e. its delay is set to 0.0 s). It is then recommended to add a small time delay (e.g. 30 ms) for Zone 1 in order to avoid any possible racing issues for the involved binary signals during earth fault clearance in a neighbouring array feeder connected to the same MV bus.
5. The “TRIP-Zx-Ph-Gnd-#2” signal shall indicate that ground distance protection with optimized directional criterion has operated.

Note that the above-described logic works in parallel with standard ground distance protection zones which perhaps will still operate for the majority of the fault cases. The standard ground distance protection zone will also operate during cross-country faults.

By implementing this logic in a distance protection IED [5] proper operation of the ground distance element during earth fault in an array cable feeder will be ensured. Therefore, it is strongly recommended to implement such optimized logic for WF installations.

In order to optimize the performance of the ground distance elements of the healthy array cable feeders during an earth fault occurring somewhere else in the MV system the following solution can be used. The magnitude of an earth fault current supplied by the grounding equipment (i.e. a combination of NGT and NGR) in practice is typically larger than the capacitive earth fault current contribution from the longest healthy feeder. If that statement is true, then it is possible to set a neutral current level above which the phase-to-ground measuring loops within distance protection are to be released for operation. When this neutral current level is properly set this will effectively disable the phase-to-ground loops for all healthy feeders during reverse earth faults and only enable distance protection phase-to-ground loops in the faulty feeder. The following settings are proposed:

1. The required threshold of an earth fault current release for the distance protection shall be set higher than the capacitive current of the array cable feeder with a safety margin.
2. A time delay for the earth fault current release for the distance protection is normally not required. However, for more challenging applications (e.g. if the capacitive earth fault current of the array cable feeder is close to the set level) a small time delay (e.g. 25 ms) can be used in order to avoid transient pickup of this element during an earth fault inception.

4 Verification of the optimized ground distance protection logic

4.1. Software simulations

The basic concept of the optimized ground distance protection logic has been tested in DlgSILENT PowerFactory using a generic model of an offshore WF and further verified via studies performed with the model of a real offshore WF.

The concept studies for the generic simplified offshore WF model (refer to Fig. 8) were designed in such a way as to analyse the response of all the additional functional elements utilized in the optimized ground distance protection logic and verify the proposed settings for the worst-case/boundary conditions in various fault scenarios using Complete method steady-state simulations [6].

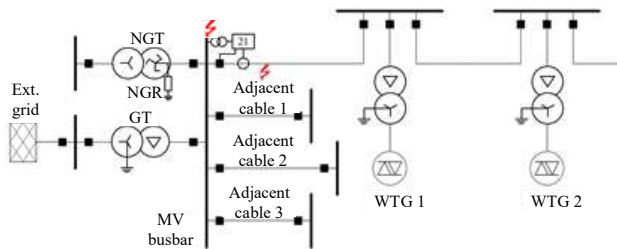

Fig. 8 SLD of generic simplified PowerFactory model

The behaviour of standard and optimized ground distance directional elements under various system conditions for the faulty array cable feeder is shown on the basis of four test cases which were carried out with the 66 kV system model presented in Fig. 8. A close-in phase L1-to-ground fault in forward and reverse direction with the fault resistance $R_F = 0 \Omega$ was simulated on the 33 km long array cable consisting of 630 mm², 400 mm² and 150 mm² sections with total zero sequence capacitance $C_0 = 9.43 \mu\text{F}$. The chosen NGR rating of 16 Ω allows high enough resistive fault current which cannot be extremely damped or overlapped by capacitive currents of the faulty and healthy adjacent array cables and the WTGs' load current. The setup of the test cases is as follows.

1. No power flow from WTGs; total length of adjacent cables of coupled collection network is 0 km. Forward fault is simulated.
2. No power flow from WTGs; total length of adjacent 400 mm² cables of coupled collection network is 100 km with $C_0 = 25.3 \mu\text{F}$. Forward fault is simulated.
3. Maximal power flow from 8 x WTG ($P = 8 \text{ MW}$, $Q = 3 \text{ Mvar}$); total length of adjacent 400 mm² cables of coupled collection network is 100 km with $C_0 = 25.3 \mu\text{F}$. Forward fault is simulated.
4. Maximal power flow from 8 x WTG ($P = 8 \text{ MW}$, $Q = 3 \text{ Mvar}$); total length of adjacent 400 mm² cables of coupled collection network is 100 km with $C_0 = 25.3 \mu\text{F}$. Reverse fault is simulated.

Table 1 presents a summary of the simulation results for the four test cases where rows 67N FW, 59N, 59PhG, 27PhPh and FW EF represent additional functional elements utilized in the optimized ground distance protection logic described in

section 3 as signals "67N-START-Fw", "59N-START", "59-START-Ph-Gnd", "27-START-Ph-Ph" and "Forward-EF-Detected" respectively; row 21N corresponds to standard distance protection element. Table 1 contains measurements of the operating values corresponding to the additional functional elements 59N, 59PhG, 27PhPh along with assessment (YES, NO) of whether the functional elements issue operating signals. For the FW EF and 21N elements an indication of the determined fault direction is also presented as FW for the forward, REV for the reverse and UDT for undetermined.

Table 1 Summary of simulation results

Function	Case 1	Case 2	Case 3	Case 4
67N FW	YES	YES	YES	NO
59N	YES 119.63 kV	YES 148.23 kV	YES 156.33 kV	YES 156.34 kV
59PhG	YES 80.7 kV	YES 99.62 kV	YES 105.06 kV	YES 105.06 kV
27PhPh	NO 55.41 kV	NO 61.91 kV	NO 65.29 kV	NO 65.29 kV
FW EF	FW	FW	FW	REV
21N	FW	UDT	UDT	REV

Analysis of data provided in Table 1 shows that the optimized ground distance protection logic works as expected for all the test cases whereas the standard ground distance protection element cannot provide correct fault direction determination for cases 2 and 3. This leads to a conclusion that the proposed optimized logic makes overall performance of the distance protection during earth faults more stable and provides reliable fault direction determination in the most challenging system conditions.

The optimized ground distance protection logic along with the proposed settings for the additional functional elements was also verified via detailed steady-state studies run on the model of a real offshore WF and it was concluded that it performs as expected for all the test scenarios.

4.2. Laboratory tests

The results and conclusions considering the performance of the optimized logic for ground distance protection directional elements obtained during steady-state Complete method software simulations has been verified in two steps as follows.

1. All the various test scenarios were reproduced with dynamic EMT simulations [6] using DlgSILENT PowerFactory and the resulting output waveforms of currents and voltages were translated into COMTRADE files.
2. The waveforms from the COMTRADE files were injected into a commercial distance protection IED where the investigated optimized ground distance protection logic was implemented. This was performed with a secondary injection test kit in a laboratory environment.

The main results and conclusions were confirmed via the secondary injection tests which showed that the response of the commercial IED using the optimized ground distance protection logic was stable in terms of correct direction determination for all the test cases including the worst-case scenarios.

5 Testing of the optimized ground distance protection logic

The following steps are proposed for factory and site acceptance secondary injection testing procedure for the IED using optimized logic for ground distance protection elements.

1. Testing of individual directional ground distance zone settings via conventional search tests or shot tests which is a standard test for ground distance protection.
2. Testing of individual settings for additional functional elements used in optimized forward earth fault detected logic for ground distance protection and its overall response. This includes pickup current and RCA for 67N directional earth fault element, pickup settings for 59N, 59 phase-to-ground, 27 phase-to-phase elements and overall test of the new forward earth fault detected logic presented in Fig. 6.
3. Testing of individual non-directional ground distance zone settings via conventional search tests or shot tests which forms a part of the test for optimized directional supervision logic for each forward-looking distance protection zone presented in Fig. 7.
4. Testing of tripping logic for optimized directional supervision functional block for each forward-looking distance protection zone presented in Fig. 7. This is to be done via shot tests for faults simulated outside of the zone of standard directional ground distance protection with fulfilled conditions for the operation of the new forward earth fault detected logic and non-directional start of ground distance zone – refer to Fig. 9.

It shall be noted that design of a fully automated testing sequence for the optimized ground distance protection elements might be troublesome due to the necessity of performing the search or shot tests for the non-directional operating characteristics of ground distance zones and fulfilling the conditions for the operation of the new forward earth fault detected logic at the same time. That's why the above-mentioned stepped testing might be a preferred option to follow.

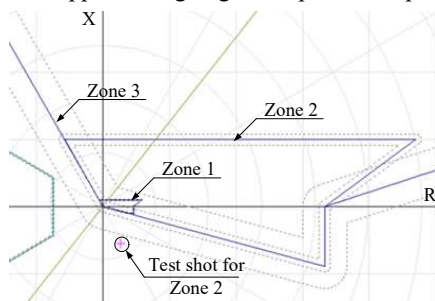

Fig. 9 Shot test for the optimized ground distance protection

6 Conclusions

This paper elaborates the problem of distance protection performance used in collection networks of WFs with resistive grounding during earth faults due to incorrect fault direction determination. A basic theory for the zero-sequence network has been introduced to explain the issue and its potential solution in more details.

It has been revealed that special measures shall be taken to optimize ground distance protection logic and ensure its proper response during earth faults which are also described in the paper. Recommendations for selection of settings for all the additional functional elements used in the optimized logic are provided.

The optimized ground distance protection logic has been tested via software simulations with the results verified in the laboratory via secondary injection testing of a commercial IED and has been proven to be fully functional and stable. Recommendations for the factory and site acceptance secondary injection testing procedures of the optimized logic are given.

The new logic proposed in the paper can be implemented to optimize the performance of the ground distance protection used in WFs collection networks and improve its selectivity and stability during earth faults. This in turn will improve reliability and availability of power generation which is high priority for WF developers, operators, and owners.

7 References

- [1] Tsylin A., Kruse-Nielsen R., Yang G., Sedaghat B.: 'Influence of collection network parameters on performance of distance protection directional elements in offshore wind farms', IET 15th Conference on Developments in Power Systems Protection, Liverpool, UK, March 2020.
- [2] Gajić, Z.: 'Challenges for earth-fault protections due to extensive use of cables in the grid', IET 15th Conference on Developments in Power Systems Protection, Liverpool, UK, March 2020.
- [3] Gajić, Z., Aganović, S., Pajunen, R., Zubić, S.: 'Universal earth-fault protection method for high impedance grounded power system', IET 15th Conference on Developments in Power Systems Protection, Liverpool, UK, March 2020.
- [4] HAPG Application Note: 'Distance Protection Application for Wind Farms', 1MRG501137, 2020. <https://search.abb.com/library/Download.aspx?DocumentID=1MRG501137&LanguageCode=en&DocumentPartId=&Action=Launch>
- [5] HAPG: 'REL670-V2.2-TechnicalManual- 1MRK506370-UEN'. Hitachi ABB Power Grids, 2021. <https://search.abb.com/library/Download.aspx?DocumentID=1MRK506370-UEN&LanguageCode=en&DocumentPartId=&Action=Launch>
- [6] DIgSILENT: 'PowerFactory 2020. User Manual', 2020.