

Transmission Line Falling Conductor Protection System Development at SDG&E®

Tariq Rahman, Chris Bolton
San Diego Gas & Electric® Company

Eric A. Udren
Quanta Technology LLC

Introduction

Many utilities are facing unprecedented levels of fire risk from routine electrical faults and failures in transmission and distribution system lines and equipment. This results from changing weather patterns which produce extreme drought conditions and violent storms. These utilities are confronting the need to deal with aging power apparatus and difficult-to-detect failure scenarios. Major fires in recent years have elevated public awareness of the risk.

San Diego Gas & Electric Company (SDG&E®) is among the California utilities facing this risk and paying close attention with innovative solutions, experimenting with, and implementing a variety of new technologies and strategies. There is not a single fix – SDG&E pursues a variety of apparatus upgrading programs, real-time situational awareness, operational and event responses, and development of protection and control (P&C) equipment and methods.

This paper begins by summarizing SDG&E's range of strategies for reducing fire risk, including grid hardening replacements, weather monitoring, adaptive operating procedures, adaptive distribution fault detection and tripping designs, and faster and more sensitive new transmission line protection schemes.

When transmission or distribution line conductors fail and fall to the ground, the resulting high-impedance arcing fault may be difficult to detect electrically yet may be capable of igniting dry flammable vegetation or creating an electrical hazard for people in the vicinity of the live downed conductor. SDG&E pioneered development of a distribution falling conductor protection (DFCP) system that collects streaming synchrophasor measurements from along a distribution circuit and can detect a break and open adjacent breakers or switches by the time the overhead conductors have fallen only a few feet. The broken conductor ends land dead; there is no arcing fault or public risk. SDG&E first deployed trial DFCP in 2015 and reported at industry forums; over 100 deployments are now in progress in high fire risk areas.

In 2019-2021, SDG&E carried out a development program for a transmission system falling conductor protection (TFCP) system, based on PMU or synchrophasor voltage and current measurements from two or three line terminals - data already being gathered for engineering and operational situational awareness client systems. This scheme is further enhanced with a sensitive backup ground differential protection scheme for very high impedance faults triggered by tree contact before or without a conductor break; this protective scheme demonstrates prospects for expanding backup fault protection with schemes based on PMU data. The new TFCP scheme is to be deployed for trial on 69 kV transmission circuits in 2022.

Grid hardening and operating adaptations

SDG&E has developed a broad fire safety enhancement program combining fundamental common-sense upgrading efforts to reduce root causes of risk with developments of new technologies to detect impending or immediate risk events at specific locations on the grid. The company has invested billions over more than a decade on its risk assessment and mitigation phase of its wildfire risk control and mitigation plan. The technical innovations described in this paper are part of this broad program.

Operational planning begins with an assessment of the cross-functional activities that impact wildfire risk reduction. These include:

- Climate change adaptation - bolstering system resilience; reducing greenhouse gas emissions.
- Asset management program including inspection and fleet assessment to identify and repair apparatus or facilities for reduction of fire risk.
- Emergency preparedness and response, including proactive response to potential risk situations and post-event analysis of response effectiveness.
- Safety management systems, including communications systems and comprehensive training of company teams on safety issues and procedures.
- Workforce training, qualification, and planning for all risk mitigation and response activities.
- Records management for continuing internal and regulatory tracking.



Figure 1: SDG&E wildfire risk bowtie

Risk Bowtie

The left side of the Figure 1 risk bowtie lists the drivers or triggers for wildfires. The common result from all these 10 driver categories is that any of them can ignite a wildfire. This is illustrated by the central red disk in the risk bowtie configuration.

Should a fire occur, the consequences shown on the right in Figure 1 are independent of the triggering event. [5] presents details of operational programs can mitigate the impact of a fire ignition, and risk scoring systems that focus investments to get the optimum risk reduction outcome. The focus of this paper, however, is technical developments to reduce the risk of ignition from triggers DT.1, DT.4, DT.5, and DT.6.

Strategies in application of conventional fault protection relays

For distribution fault protection, SDG&E uses two adaptations:

Sensitive Relay Profile (SRP) settings - With conventional time-overcurrent protection settings, it may take seconds to clear a fault. A special group or profile of relay or recloser protection sensitivity and tripping time settings can be engaged by distribution operations at times of high fire risk. The setpoints are set as sensitively as possible without tripping for normal load conditions and will clear a fault in less than 4 power cycles or 70 ms.

To achieve optimum speed and sensitivity, historical five-year loading profiles on individual devices and circuits are gathered via SCADA data communications from each recloser. SDG&E has developed an automated data processing tool that analyzes the loading history of every device in high fire risk districts to flag SRP setpoints that need reverification and updating of operator decision logic.

When elevated or extreme fire risk weather conditions are forecasted by SDG&E's meteorologists, operators remotely switch a pre-defined list of reclosers to SRP profile the prior night. These SRP settings do not coordinate with other protective devices such as fuses or other reclosers further down the circuit—fault will trigger uncoordinated tripping of multiple devices and will de-energize larger sections of the feeder, impacting more loads and requiring more extensive patrols to locate the problem and ensure that the circuit is clear for re-energization. In service experience, SRP has prevented fire ignitions, outweighing the loss of protection coordination and larger extent of outages.

Sensitive Ground Fault (SGF) protection - Some distribution faults cannot be detected by relays or reclosers using standard ground overcurrent protection settings. The standard settings are typically high enough to avoid tripping for normal phase load imbalances, which look to the relays and reclosers like low-current ground faults of the same magnitude as the imbalance. SGF replaces standard ground current magnitude trip settings with values that are customized for each device, set just above the normal unbalance seen by that device.

Just as with SRP, setting SGF protection requires constant review and adjustment of individual protection settings in comparison to field load data history to avoid trips for load imbalance. SDG&E uses specially developed analytic tools to study the actual range of load-induced circuit current imbalance for each relay or recloser reporting load profiles, using system-wide continuous operating measurements collected by SCADA - the same loading data and tool

systems used to determine annual baselines for SRP settings before each fire season. With this device-customized load imbalance profile, each device can be set just above its worst normal imbalance level with minimized risk of false tripping for normal loading. On well-balanced circuits, the setting can be far lower and more sensitive than standardized settings.

SDG&E applies SGF settings year-round. As with conventional time-overcurrent protection, SGF is time-coordinated by setting a half-second delay interval between tripping times of reclosers along a circuit. This time delay minimizes the reliability impact by isolating a smaller section of the circuit when a fault occurs, and thus enables the full-time use of SGF.

Distribution falling conductor protection (DFCP)

The purpose of FCP is to detect an energized conductor that has broken and to de-energize it before it strikes the ground, thereby eliminating the risk of fire ignition or public exposure to live conductors. SDG&E and other utilities experience such conductor breaks even with vigorous circuit-hardening programs. An SDG&E project team invented and patented the concept and scheme of FCP while developing new synchrophasor-based distribution circuit monitoring and protection system technology.

Figure 2 shows the time sequence for a broken overhead distribution conductor falling from a height of 30 feet (9 m). Accelerating from the moment of the break, one or both ends reach the ground 1.37 s later. The FCP scheme can detect the break from circuit voltage signatures and issue trip commands so that the broken circuit section is de-energized 200 to 500 ms after the break—when the conductors have fallen only a few feet.

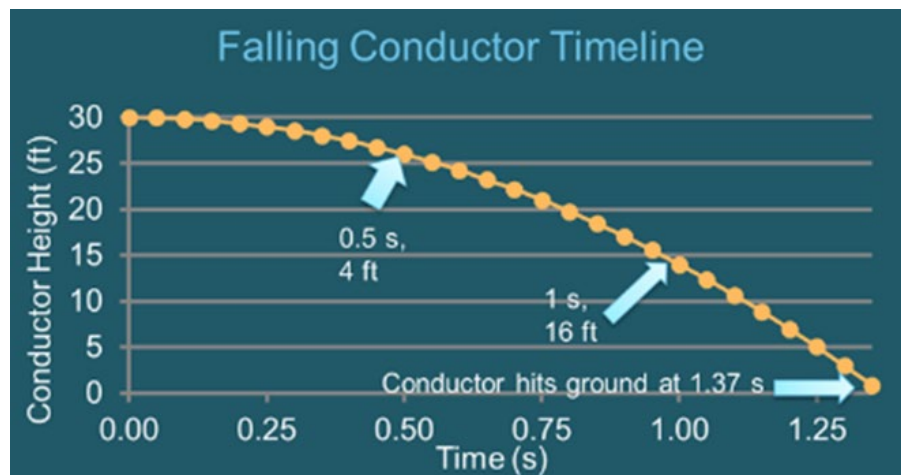

Figure 2: Distribution falling conductor protection (DFCP) operational timing

Scheme components

The system utilizes PMU-enabled protection and control intelligent electronic devices (IEDs) along the distribution circuit, an Ethernet circuit-area high-speed data communications system, and a substation-based phasor data concentrator (PDC) that streams collected synchrophasor streams to an adjacent real-time automation controller. The controller holistically processes all the circuit measurements with algorithms developed by the SDG&E project team to detect the break between two measurement locations. The controller can send trip commands to the

circuit protection IEDs on circuit switching devices that can isolate the break, typically within 100 milliseconds of detection.

Figure 3 shows a typical distribution circuit radiating from a distribution substation with arrays of circuit IEDs communicating with the substation scheme controller. The normally open Recloser 3 can be included in the FCP scheme with its streaming PMU measurements to handle changing circuit configurations.

Substation and circuit IEDs

The IEDs participating in circuit FCP include the protective relays at substation circuit breakers and recloser controllers and voltage monitors distributed along the circuit. The scheme uses commercially available IEDs that are, in addition to their conventional protection and control and SCADA functions, capable of streaming synchrophasor voltage and current measurements from circuit voltage and current sensors via high-speed communications at a rate of 30 or 60 synchrophasor sets per second.

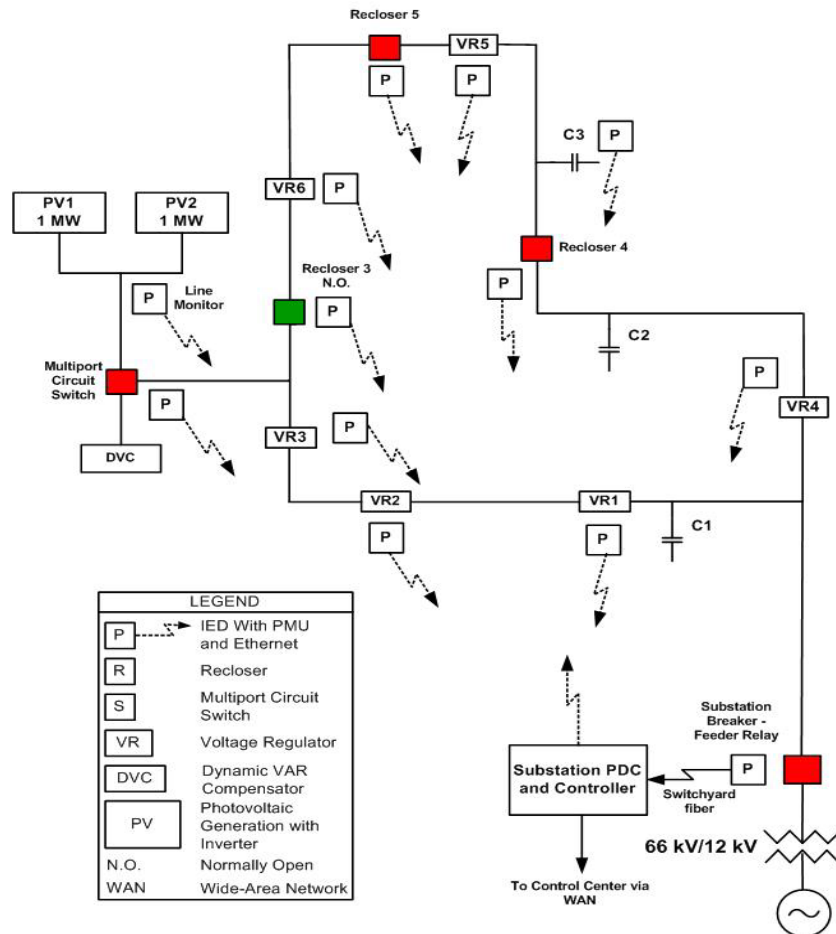

Figure 3: FCP circuit IED deployment example

If the substation controller detects a conductor break, it sends high-speed tripping commands to circuit switching devices – reclosers, circuit breakers, or high-speed transfer switches – over

the same communications network that is used to collect the synchrophasor measurements used by the algorithms.

High-speed data communications

Figure 4 shows how circuit IEDs are each coupled to an Ethernet radio network to transport the PMU data stream of 30 to 60 frames per second back to the substation for processing. For returned FCP tripping commands, the controller publishes high speed tripping commands using the standard IEC 61850 Generic Object-Oriented Substation Event (GOOSE) message packet specification; circuit controller IEDs subscribe to the Ethernet GOOSE message packet stream.

Fiber-optic connections are used within the substation to connect PMU-enabled feeder relays to the PDC; fibers along distribution circuit paths may be available in place of radio paths in selected service areas with high load density.

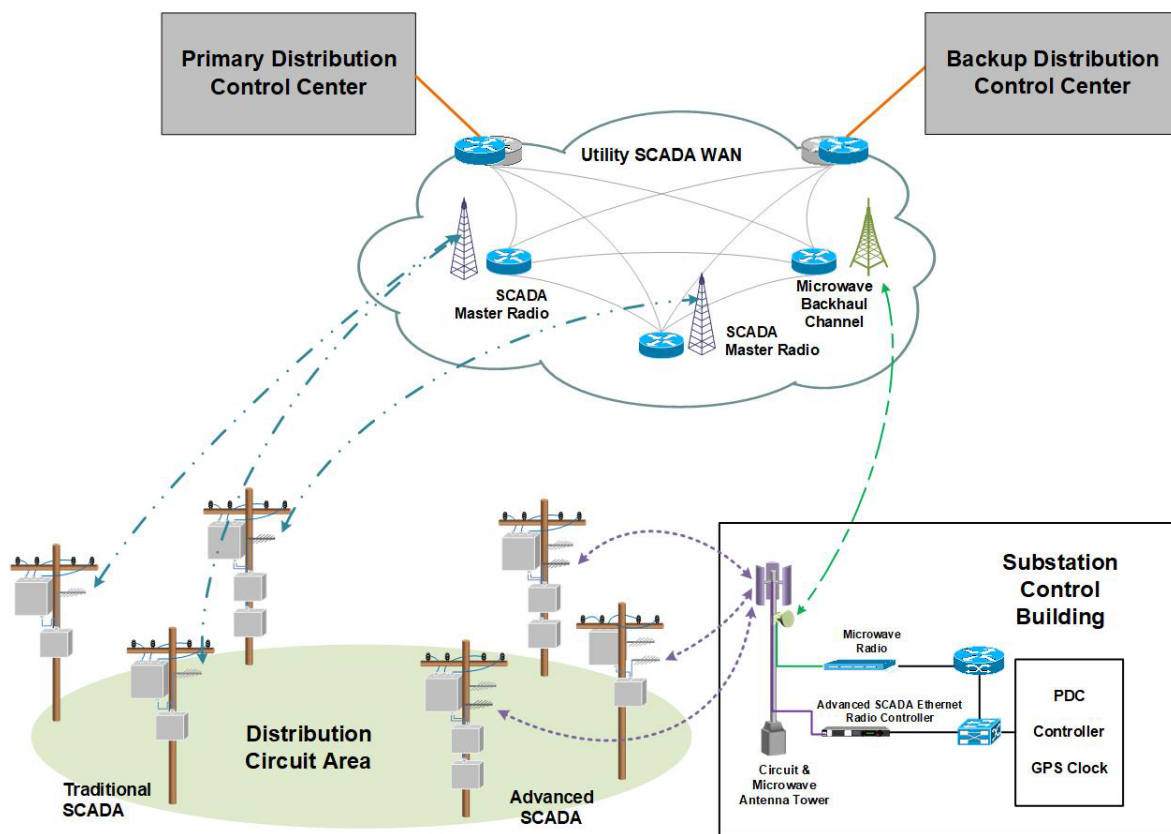

Figure 4: FCP radio communications architecture

FCP requires robust communications links that provide consistently high data rates and low packet loss rates. Recent FCP deployments use wideband ethernet mesh, point-to-point, and point-to-multipoint radio systems with repeaters that can transport synchrophasor streams with latency or time delay of under 50 ms. Figure 5 also shows how the high-speed radio communications for PMU data and tripping are overlaid on SDG&E's legacy wide-area and lower-speed distribution SCADA radio system so that both systems can operate simultaneously over the many years during which advanced high-speed data collection and communications are deployed across the SDG&E distribution system. The lower right portion shows a

substation-based radio communications hub tied to FCP controller system components as explained just below. Circuit synchrophasor measurements and FCP system data are transferred to control centers via the backhaul connection from the substation through the wide-area network to control centers. The traditional SCADA communications system on the lower right comprises a lower-speed, wide area radio system exchanging data with circuit devices across the service area every few seconds. The traditional and advanced communications paths can be overlaid even on a single communications circuit.

SDG&E is deploying privately owned LTE cellular radio systems for a variety of grid monitoring and control applications; new FCP deployments operate over this expanding cellular communications network with its effective coverage and modern cybersecurity management.



Figure 5: FCP substation IEDs

Substation processing array

At the substation terminating each FCP-equipped circuit, the high-speed data radio system host transceiver node is combined on a rack with PDC, FCP-programmed automation controller, Ethernet switch, and GPS receiver for precision system measurement and event timing as shown in Figure 5. In newer deployments, PDC and FCP functions are combined in a single next-generation automation controller

In some FCP installations, the PDC concentrates and streams the entire circuit PMU data array from across the circuit over a wideband backhaul channel to a wide-area network data-center server as Figure 4 showed. These full PMU measurement records are available to engineers for near real-time circuit observation, event analysis, archiving, and development of other distribution PMU applications like circuit voltage and current profile monitoring.

Scheme operation

The controller receives a new set of phasor frames from across the monitored circuit 30 or 60 times per second. With each new frame, the controller executes a sequence of five algorithms that analyze three-phase voltage relationships over a series of frame times. A

conductor break produces a unique shift in relationships among phase voltage magnitudes and/or angles. For example, Figure 6 shows how a composite extraction of angles from the three-phase voltages (negative- and zero-sequence voltage angles) across the circuit bracket the location of a break. At the moment of a break, the extracted angles shift position, showing a characteristic difference between angles on either side of the break. Comparison of these extracted angles across the circuit and over several synchrophasor frame intervals gives a reliable indication of the circuit section with the broken conductor and triggers an IEC 61850 GOOSE trip command to the nearest switching devices on either side of the break. The controller delivers a SCADA alarm to the control center to alert an operator on specifics of the FCP isolation of a broken wire. This prompts an immediate field response to investigate the open circuit section, repair the break, and restore service.

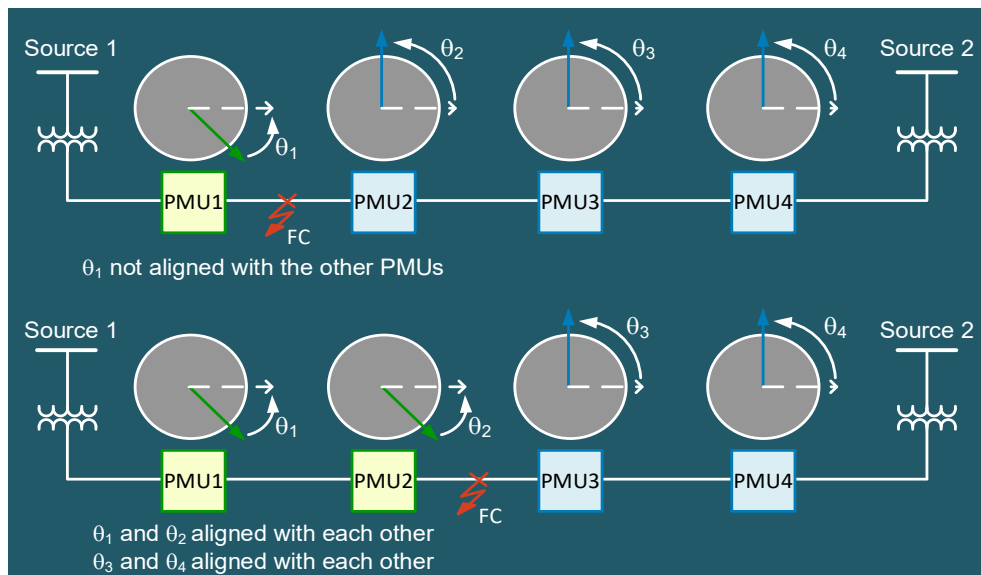

Figure 6: Conductor break location from relationships of V_2/V_0 phase angles along circuit

FCP experts perform post-mortem analysis on historized synchrophasor and event records to ensure the system operated correctly and to guide algorithm improvements.

The five algorithms have been developed in extensive laboratory testing on a real-time digital simulation of a real feeder with varying loads, imbalances, and connected inverter-based energy sources. Each algorithm has the strongest detection capability for certain operating conditions. For the full range of circuit loading, load unbalance, and photovoltaic generation at high or low levels, multiple algorithms can detect a conductor break. The testing regimen also demonstrated security, or resistance to undesired operation, for normal switching events and unbalances from single-phase load switching or misalignments of voltage regulator taps. For faults, relay or recloser control pickup blocks FCP so the relays and fault protective devices on the circuit can execute properly located and timed trip decisions.

Experience and deployment plans

FCP is currently operating on seven distribution circuits with dozens more in development. Ultimately, SDG&E is planning FCP deployment on more than 150 distribution circuits. FCP

applies to all circuits within Tier 2 and Tier 3 of the California utilities' high fire threat districts. Thousands of PMU-enabled IEDs will be placed in service to gather measurements from across these circuits.

Other drivers for FCP system deployment

SDG&E has seen massive penetration of customer photovoltaic and distributed energy resources on its transmission and distribution systems for more than a decade, fundamentally altering power flows and electrical behavior of the grid as well as the business of coordinating energy supply across the region. Although FCP has drawn attention as wildfires become a chronic threat, drivers for other applications of PMU data collection are also growing to critical importance. The movement towards high DER penetration brings new visibility and operating requirements and adds huge value to the new synchronized data gathering system that serves FCP. Among the new use cases for the FCP gathering and processing infrastructure are:

- High-accuracy fault detection and location
- Wide area visualization and advanced monitoring of the distribution grid
- Advanced real-time distribution system operation beyond today's SCADA capabilities
- Advanced distribution system planning
- DER integration and operation
- Distribution load, DER production, and electric vehicle demand forecasting
- Monitoring and control of electric transportation infrastructure
- Power apparatus monitoring and diagnosis
- Asset management of critical infrastructure
- Advanced microgrid applications and operation

PMU data streams already being collected from the first FCP installations assist with development of these new use cases.

Transmission initiatives for fast fault clearing and fire risk reduction

Transmission line fault protection and teleprotection

Quickly and accurately locating faults is key for long transmission lines traversing difficult-to-patrol terrain, and this becomes even more critical during fire season. SDG&E is now deploying the latest generation of relays with traveling wave fault location for 500 kV, 230kV, and 69kV transmission lines. The location can potentially be determined within one tower span and reported to operations from the relay the instant the fault occurs. SDG&E is also using an overlaid GIS map to help field crews pinpoint the location reported by the relay. Traveling wave line monitoring also can detect temporary disturbances from equipment such as specific insulators that could cause permanent faults in the future, flagging circuits for inspection and repair.

PMU-based wide-area situational awareness (WASA) and transmission visualization system

SDG&E is among many utilities deploying WASA systems in which PMUs distributed across the grid are streaming data to system operators at control centers for situational awareness of dynamic wide-area behavior of the grid. The WASA deployment has evolved from a grid observation system built on PMU deployment over the last decade, now extending to most transmission lines and other system elements. It is presently covering all 230 kV and 500 kV buses and transmission lines and is proliferating into the 138 kV and 69 kV systems. The PMUs are streaming data at 30 or 60 frames per second providing exact time and angle relationships of power-frequency voltage and current measurements from most lines.

Today's system serves as a tool for engineers and operators to observe system behavior and perform post-mortem analysis of disturbances and events. The system has been installed in the transmission system operator console as a non-operational tool for the past decade. This has enabled operators to get familiar with the new technology, understand system events and data in real-time, and review events and data which are not observable via the EMS. Streamed grid measurements and system status displays are available for operators as the example of Figure 7 shows (actual system map which operators see on the left of the screen is redacted). A new WASA architecture with advanced cybersecurity design and regulatory security compliance is currently being deployed for real-time operations to complement the EMS system.

Several wildfire management applications are being developed for the WASA system, including a multi-layered GIS map-based visualization software system that will show accurate fault location, plus point-on wave event and weather (wind, fire, and lightning) data, helping the company quickly dispatch personnel, conduct event analyses and restoration, and manage public safety power switching (PSPS) events.

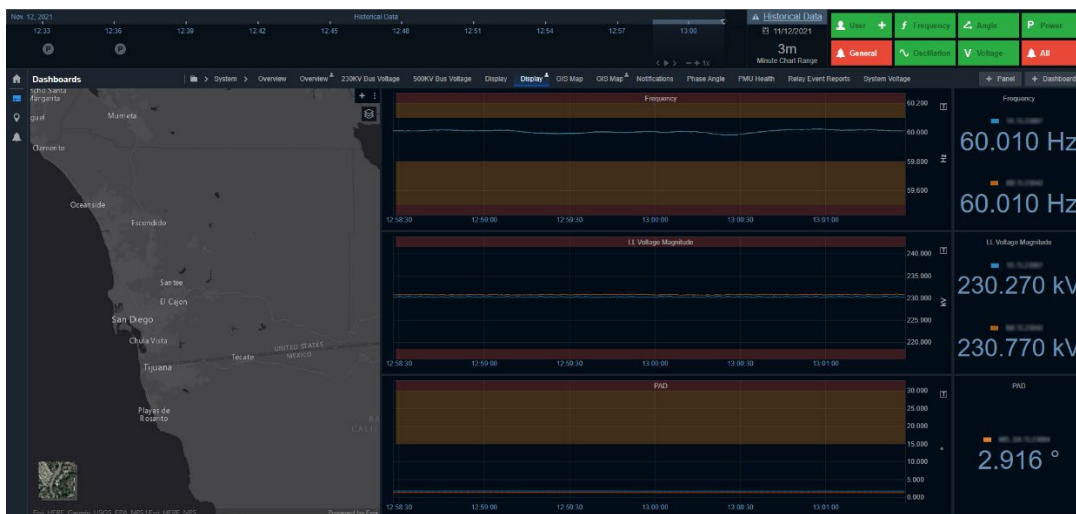

Figure 7: Typical WASA display for system operator

Transmission Falling Conductor Protection (TFCP) Systems

We explained above how SDG&E pioneered development of a distribution FCP system that collects streaming synchrophasor measurements from along distribution circuits and rapidly trips a circuit section with a broken conductor so that the conductor lands dead. In 2019-21, SDG&E built on this experience to develop TFCP systems. One scheme is based on real-time

processing of the PMU data streams already being collected from ubiquitous transmission substation PMUs serving the WASA system. Figure 9 shows a typical TFCP system configuration for a two-terminal transmission line. TFCP schemes are being deployed for trial on 69 kV transmission circuits in 2022.

Figure 2 showed the timeline for a falling distribution conductor from 30 feet or 9 m. A broken overhead transmission conductor 60 feet (18 m) in the air takes even longer - almost 2 seconds to reach the ground as shown in Figure 9. With PMU measurements and detection algorithms, substation controllers and relays can trip line terminal breakers and clear the line by the time the failed conductor has fallen only a few feet. It lands on the ground or underbuilt infrastructure de-energized, and fire ignition risk is avoided.

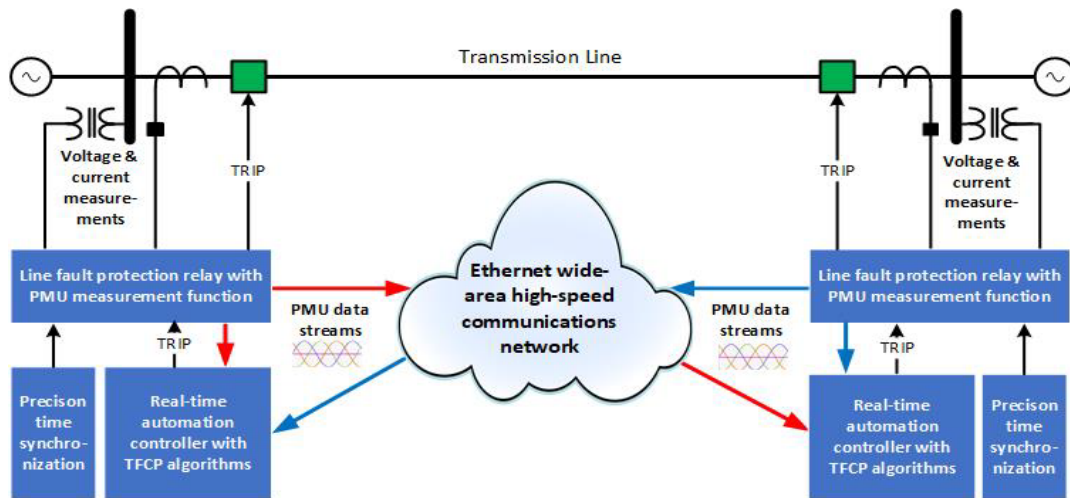

Figure 8: Components of a transmission falling conductor protection (TFCP) system

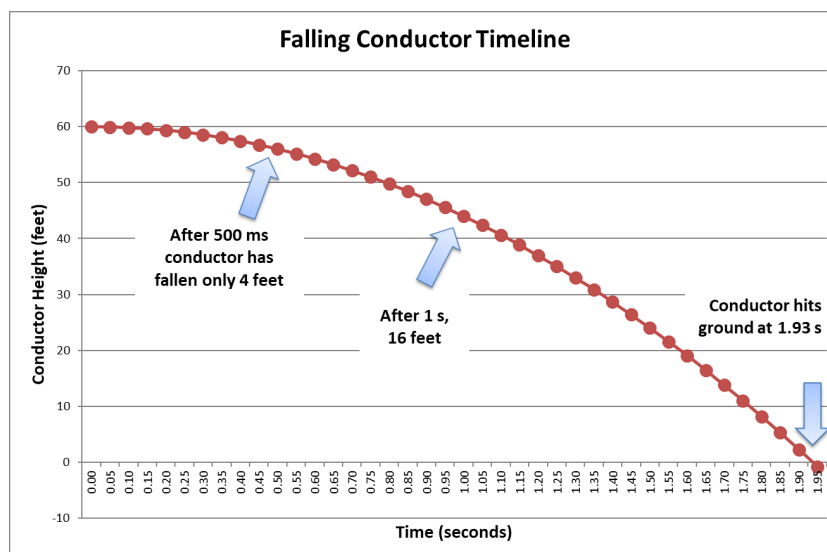

Figure 9: Transmission falling conductor operational timing

The TFCP measurement system and algorithms are fundamentally different from those developed for distribution FCP and depend more heavily on circuit current measurements. One

TFCP method uses synchronized current comparisons from the line terminal PMU data streams to observe pre-event load flows and rapidly detect conductor breaks, even on multiterminal lines. Charging currents into the broken conductor sections from each end help to locate the break for rapid field crew deployment. Along with the FCP algorithms, the TFCP scheme includes high-sensitivity ground fault detection to trip within a few power cycles for non-break fire-risk events like tree branches falling on or blowing into lines from outside the vegetation-management right-of-way, as described further below.

The TFCP system can detect and de-energize the line in less than 400 ms for falling conductor events or arcing ground faults of thousands of ohms whether accompanied by a break or not. The design is based on automation controllers installed in substations adjacent to protective relays. PMU data streams from local relays and remote line terminals – the same data streams supplied to the WASA system at the control center – supply the controller with complete real-time current and voltage measurements. Programmed algorithms detect evidence of a conductor break or low-current ground fault and issue trip commands through local relay outputs to line circuit breakers. Some relays are also programmed with internal logic that can detect conductor breaks in parallel with the scheme based on PMUs and automation controllers.

TFCP equipment and programming have been extensively tested on a model of a section of the SDG&E 69 kV transmission system, programmed on real-time digital simulator (RTDS®) arrays in the SDG&E Integrated Technology Facility (ITF) laboratory and at developer sites. In laboratory hardware-in-the-loop tests, the TFCP solution has demonstrated its tripping speed, dependability, and avoidance of undesired operation for a host of break simulations, faults, and operating events on the protected line and the adjacent power system elements. The TFCP controllers capture records of PMU data surrounding an apparent break or ground fault in Excel format for post-mortem plotting of algorithm performance and event replay using PC tools.

Figures 10a and 10b show example plots of TFCP operation for a simulated break of a 69 kV line carrying load. Each time increment (trace dot) is a synchronized measurement frame time of 16.7 ms (60 PMU data frames per second). The real-time digital simulator model of the break event includes a simulation of the series arc that may occur as the broken load-carrying conductor ends separate. Automation controller logic checks for normal line operation before the event as well as a variety of conditions to distinguish a conductor break from other types of events. Break detection is confirmed within 2 to 3 data frames or less than 50 ms.

Architectural flexibility

For laboratory testing and first field demonstration, the project team programmed PMU data processing algorithms on a real-time automation controller that can be installed at one of the terminal substations. However, a system-wide deployment does not require ubiquitous substation controllers.

For widespread long-term deployment, a TFCP algorithm implementation is programmed in client software in a control or data center platform networked to PMU data collection already being done for WASA or wide area protection, automation, and control (WAMPAC). This is simply another WAMPAC application on these central servers, protecting the entire PMU-

instrumented transmission grid from falling conductor issues. It adds no new equipment at substations, although it requires channels through which to rapidly trip substation breakers if a conductor break or fault is detected. Tripping can be via IEC 61850 GOOSE to substation relays and breakers over the same Ethernet network used to collect PMU data, or another form of transfer trip communications.

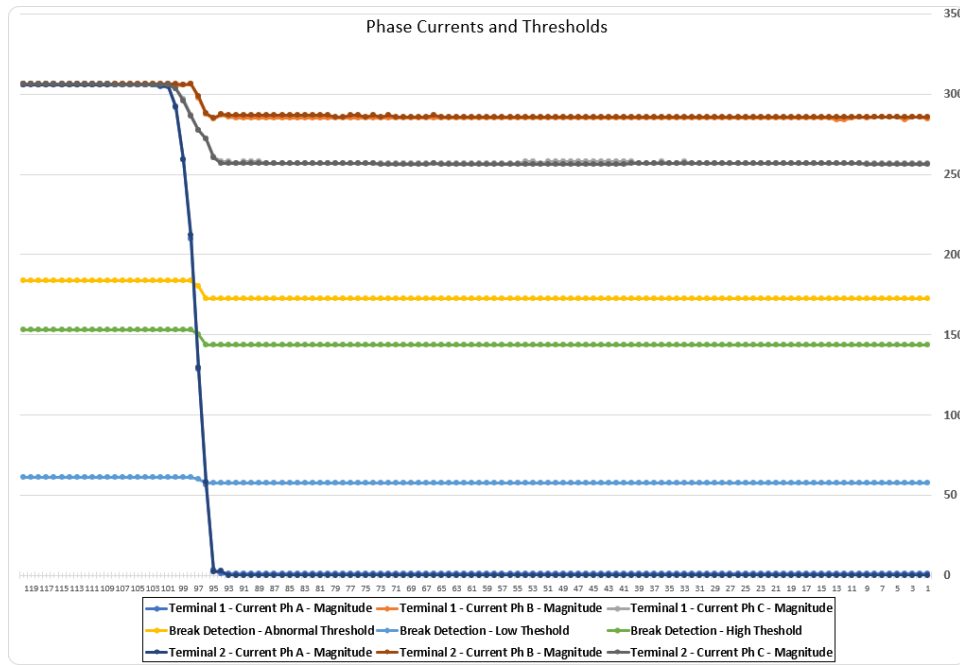

Figure 10a: Break detection in Phase A – phase currents and thresholds

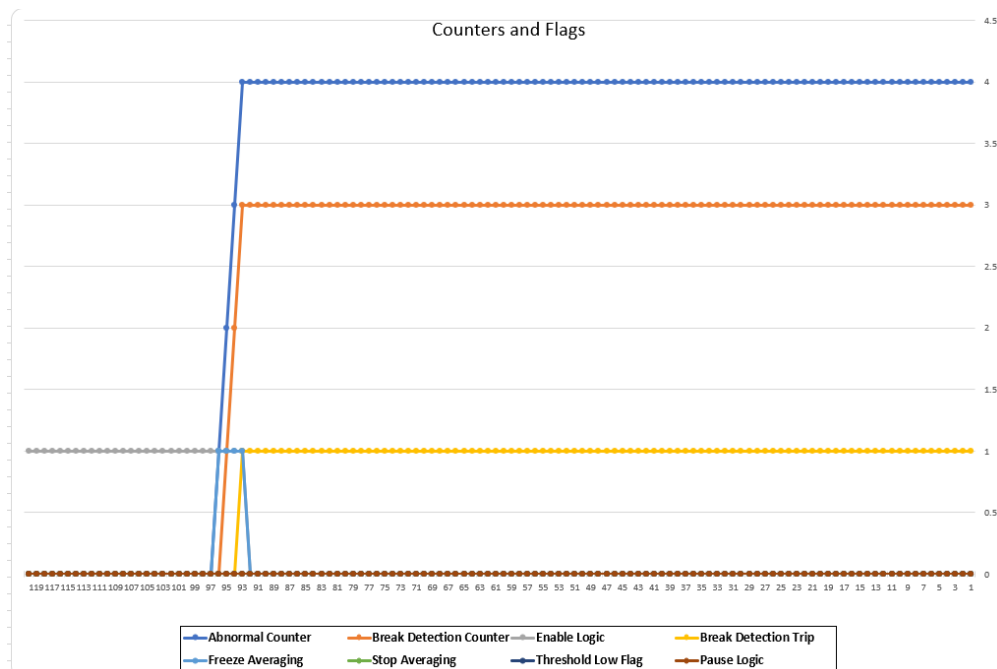

Figure 10b: Break detection in Phase A – counters and flags

The entire scheme of PMUs, communications, servers, & outbound tripping channels are self-monitoring and thus bring no additional maintenance requirements for the new protection capability. This scheme does not add significant equipment to achieve FCP or backup fault protection benefits for the entire transmission grid.

Limitations

TFCP works on single line conductors that break – this covers the overwhelming majority of HV transmission lines, including those in high fire risk areas. It is not effective for EHV bundled-conductor lines. If one conductor of a bundle breaks, phase current continues without disturbance and there is no change to measure until a ground fault occurs. These EHV lines are not the primary source of fire ignition risk with robust construction, fewer circuit miles, and wider and more carefully maintained rights of way.

PMU-based 87LN fault detection

The developers considered the reality that TFCP is not effective if a tree branch contacts a live conductor. What can we add to TFCP to help with high-impedance non-break fault incidents? Can we detect very low current faults, tough for existing ground relays to detect?

The same filtered and stable PMU current value streams used for WASA and TFCP can be integrated in a ground current differential 87LN calculation, in the same computing platform used for TFCP. Separate current differential algorithms detect ground faults, even with thousands of ohms of resistance, and issue trip commands within a similar detection time frame.

87LN protection comprises a summation of PMU current measurements from two or three line terminal phase currents, with additional supervising and sequencing logic for security during switching and startup. The net ground current sum is close to zero during normal line operation. Familiar zero-sequence harmonic distortion is suppressed in PMU data, at the cost of 2-3 cycles of filtering delay. CT errors create small errors in summation current which are stable and can be compensated. Tapped loads from delta-wye connected transformers do not impact protection measurement.

The operating regime is restricted to fault currents below about 2 p.u. – high-current faults that could saturate CTs and cause misoperation of differential schemes are well handled by conventional line relays. Thus, a percentage-differential characteristic not needed. The design uses load magnitude adjusted pickup sensitivity which has proven effective in testing described below.

The benefit of PMU-based 87LN is the potential for sensitivity to high-resistance ground faults. RTDS® tests have shown reliable tripping for faults of 3000 to 5000 ohms without external fault tripping risk. Even this sensitivity is limited by concern for CT error currents only approximated in the RTDS model; field experience may support more sensitive decision thresholds. The developers are also now working with patented new detection overlay methods that may have even much higher sensitivity – favorable results will be reported in the future if the methods succeed.

Wide-area fault and swing protection (WASP)

For utilities deploying WASA or WAMPAC with high-density PMU measurements across the transmission grid as in the Figure 11 example, the 87LN sensitive ground fault function is demonstrating effective, secure PMU-based backup fault protection from synchrophasor streams. Strong test results for 87LN in TFCP development show how a combination of this ground fault detection and 87L phase protection can be applied in a WASP scheme that offers a backup fault protection capability that is precisely selective. [4] gives a complete explanation of the concept; it also explains how voltage synchrophasors can be used for swing and stability protection in addition to differential fault protection with PMU current streams.

WASP is implemented in an application platform at the control or data center, as we proposed above for TFCP implementation without new substation equipment. WASP is slower than primary relaying (3 cycles or more) but much faster than remote distance backup. In data-center applications, protect expanding zones to back up all protection & breaker failures in a transmission voltage tier, faster than Zone2/Zone3 backup. It comprises a completely independent, self-monitoring backup protection system with no critical application settings, in contrast to distance backup which are difficult to coordinate and whose settings must be studied and evolved as bus duties and generation source mix change. WASP trips dependably with weak or variable infeed from IBR or other DER.

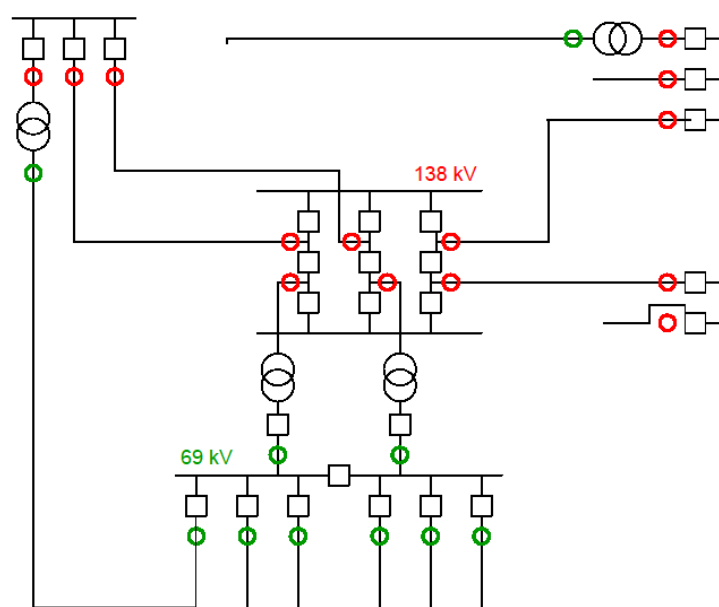

Figure 11: Transmission system with full PMU deployment across voltage tiers for WASA and WASP

In the description of [4], a centralized PMU-based backup fault protection controller observes current summations across the region and backs up local relays. After observing prolonged fault duration, the backup scheme surgically removes faults left by failed relays or stuck

breakers, tripping only the breakers required to deal with the specific local protection malfunction. The scheme does not inhibit the performance of local high-speed relays, and it isolates the fault with less time delay and more surgically focused tripping than would be carried out by distance backup relays. Non-communicating Z2/Z3 distance relay zones can be left in service as a safety net – they will always be lagging the PMU-based wide-area protection scheme. This safety net role for the distance relays brings relief from today’s critical setting demands.

Wide-area synchrophasor-based backup protection is sensitive and effective even for systems with low or unpredictable fault current caused by major penetration of inverter-based generation, and it does not trip for stable or unstable system swings.

Laboratory testing

Figures 12 and 13 show the configuration of relays, automation controllers, real-time simulator signal output connections, relay test sets serving as simulator signal amplifiers for relays, and data-gathering communications in the SDG&E Integrated Test Facility (ITF) test laboratory.

The relays include PMU capability and streamed synchrophasors to the automation controller for TFCP testing. In addition to the PMU-based scheme, the tests included parallel testing of falling conductor protection logic embedded in logic of a new relay design from a commercial vendor.

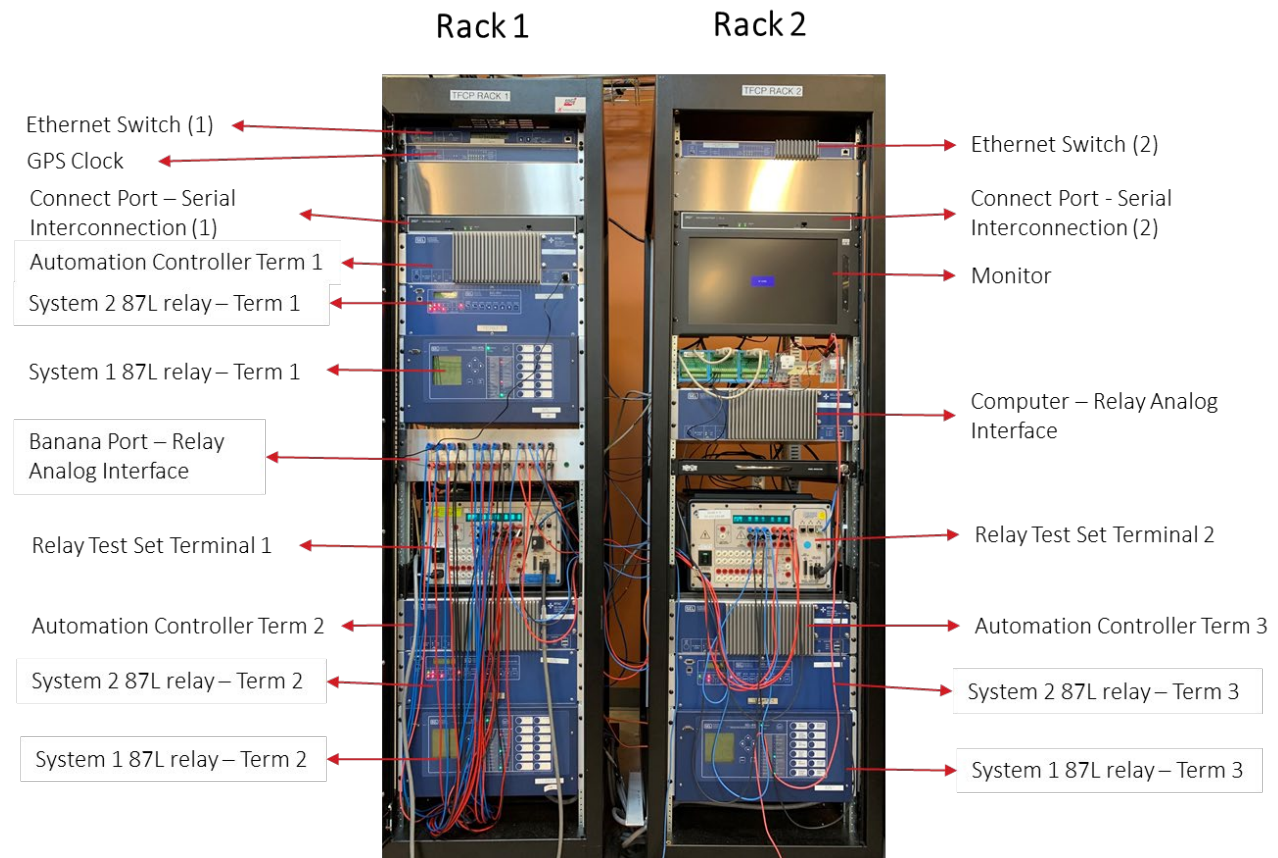

Figure 12: RTDS equipment rack configurations for TFCP and 87LN testing

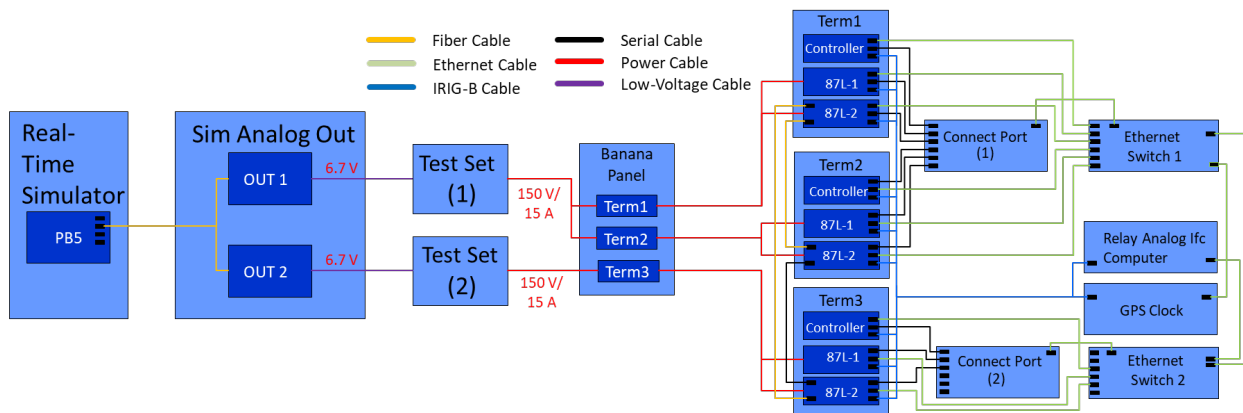

Figure 13: Connection of RTDS and test rack equipment for TFCP tests and evaluation

Figure 14 shows the RTDS model for a section of the SDG&E 69 kV transmission system. The model included simulations of conductor breaks that include modeling of the series arc that occurs as the broken conductor ends separate. The breaks were placed at moveable locations on the protected line and on adjacent lines, for which the scheme should not operate. The modeling also includes application of high-resistance ground and phase faults for testing of the 87LN high-impedance fault detection scheme in the TFCP PMU controller system.

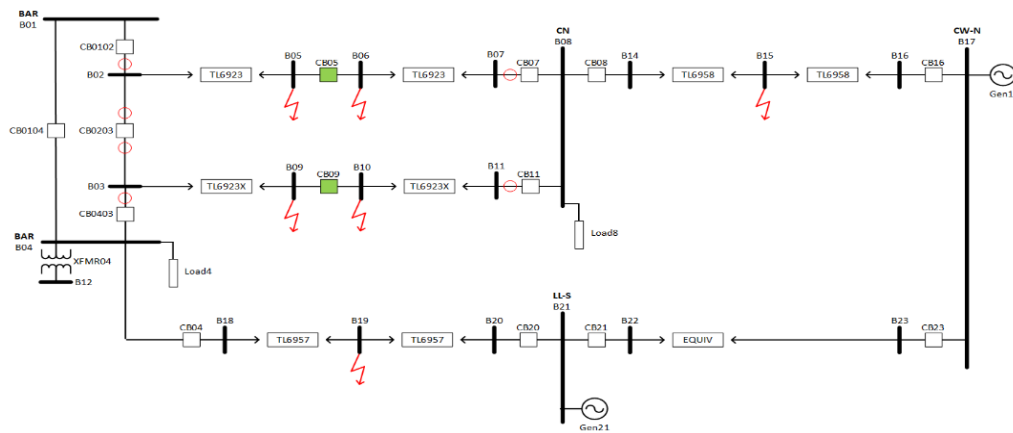

Figure 14: Simplified illustration of RTDS model of 69 kV transmission system with simulated breaks and high impedance faults

Figure 15 shows an example of the many operational displays that can be viewed on a PC connected to the TFCP controller for performance observation, monitoring, and data retrieval. The PC viewing can be remote from the substation via data communications to the automation controller web server and is not required for TFCP or 87LN operation. Displays include the shown running overview & event screen, logic states & measurement details, single-ended break detection details, multi-terminal break detection details, settings & validation screen, alarm screen, and real-time V & I calculations.

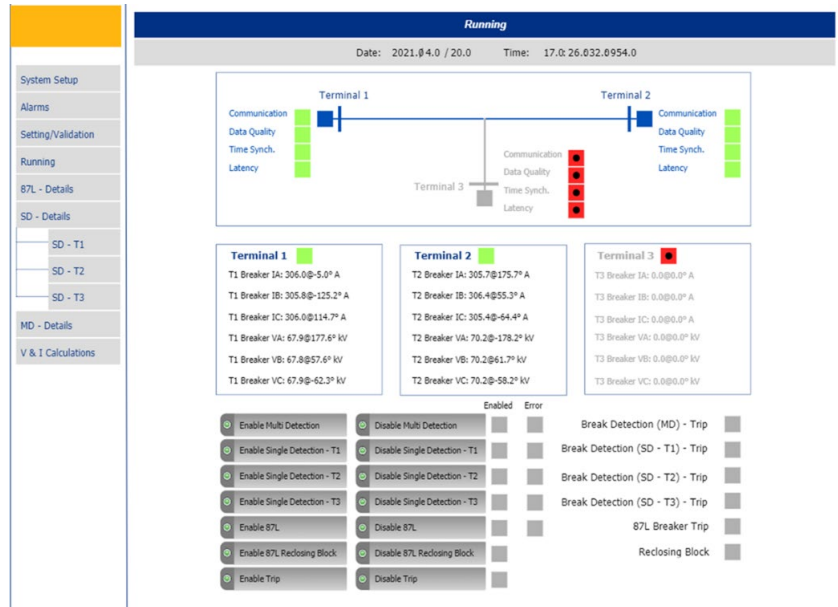

Figure 15: Example PMU TFCP and 87LN protection scheme operating display on PC

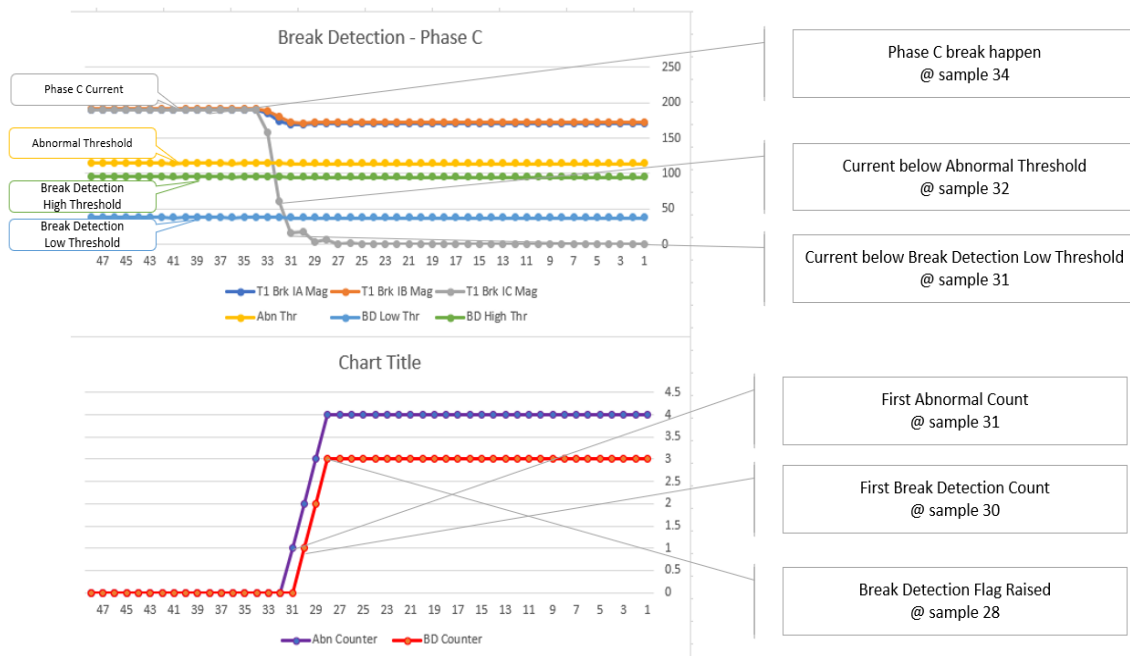

Figure 16: Example TFCP test result

Test results

Figure 16 shows the result of an example TFCP test. The controller exports .csv files readable in Microsoft Excel or other applications. The system developers created a batch processing tool that gathers multiple FCP or 87LN operating records, formats the Excel data, and plots the results as shown. The completed design operated as expected in all cases. It operates from PMU data streams at either 30 or 60 value sets per second; SDG&E PMUs operate at 60 per second. It trips for every case of single-phase or two-phase conductor break within 200 ms,

under a full range of load flows from charging current to 80 MW. It does not trip for external breaks, faults, or breaker operations.

Figure 17 shows a typical 87LN tripping response for a high impedance fault. It trips for any fault impedance up to the sensitivity limit of 3500 to 5000 ohms (I_R range 3-5 A pri.) depending on the load flow. Typical trip time is 4 cycles. It does not operate for external faults or conductor breaks.

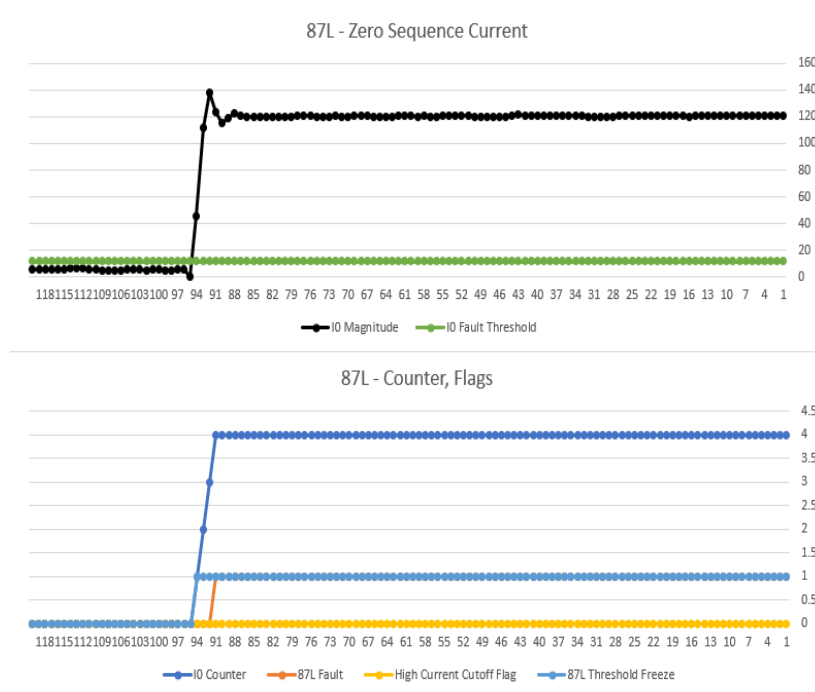

Figure 17: Example 87LN fault test result

Parallel test of commercial relay product with internal detection logic for TFCP

In one laboratory testing session, the PMU-based scheme and a commercial relay product with internal TFCP logic were tested in parallel on an RTDS model of the three-terminal 69 kV transmission line chosen by SDG&E for subsequent field evaluation. Figure 18 summarizes the test results. For the cases tested, both systems performed exactly as expected.

Test Status	Test Number	Broken Conductor or Phase	Broken Conductor Distance (miles)	Loading	Should conductor break be detected?	CW Relay Behavior	DE Relay Behavior	GC Relay Behavior
Previously Tested	1	B	0.1 behind CW	Normal	No	No Trip	No Trip	No Trip
	2	C	Close in at CW (99% tap-CW)	Normal	Yes	Trip - C phase detected	Trip - DTT	Trip - DTT
	3	A	50% tap-CW	Normal	Yes	Trip - A phase detected	Trip - DTT	Trip - DTT
	4	B	Close-in at tap (1% tap-CW)	Normal	Yes	Trip - B phase detected	Trip - DTT	Trip - DTT
	5	C	0.1 behind DE	Normal	No	No Trip	No Trip	No Trip
	6	A	Close in at DE (99% tap-DE)	Normal	Yes	Trip - DTT	Trip - Phase A Detected	Trip - DTT
	7	B	50% tap-DE	Normal	Yes	Trip - DTT	Trip - Phase B Detected	Trip - DTT
	8	C	Close-in at tap (1% tap-DE)	Normal	Yes	Trip - DTT	Trip - Phase C Detected	Trip - DTT
New Tests	9	A	Close-in at tap (99% GC-tap)	Normal	Yes	Trip - DTT	Trip - DTT	Trip - Phase A Detected
	10	B	0.05 from Tapped XFMR (50% slider)	Normal	Yes	Trip - DTT	Trip - DTT	Trip - Phase B Detected
	11	C	Close-in at GC (1% GC-tap)	Normal	Yes	Trip - DTT	Trip - DTT	Trip - Phase C Detected

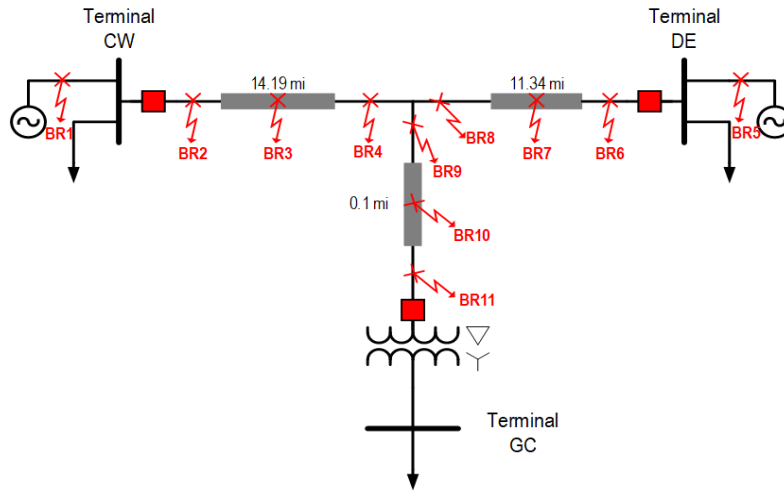

Figure 18: RTDS parallel test of PMU-based TFCP and relay internal logic for FCP on SDG&E field test line model

Summary

SDG&E is among electric utilities facing an alarming increase in wildfire risks due to changing weather patterns and drought. Fires can be triggered by faults and failures or by dry vegetation contacting operating power apparatus. SDG&E has confronted this risk for over a decade with a combination of operating and situational awareness innovations, organizational preparedness, hardening of system infrastructure, and sustained technical innovation.

On the innovation front, initiatives include invention of distribution and transmission falling conductor protection (FCP), based on PMU measurements. For distribution applications, SDG&E has been deploying FCP on circuits in high fire risk areas, with 150 circuits to be equipped over years.

For transmission, TFCP can be implemented with existing PMU streams from relays supporting the already-deployed control center WASA system. Tests using a substation controller demonstration platform show dependable tripping performance for conductor breaks under the full range of circuit operating conditions.

The TFCP implementation is augmented with an 87LN ground differential protective function that can trip the line for non-break events of tree contact with fault resistance of up to 5000 ohms, with further development on methods to increase this sensitivity. Demonstrated 87LN

performance sets the stage for development of WASP wide-area backup system protection based on the same PMU measurements.

RTDS laboratory tests of multiple TFCP schemes including the PMU-based demonstration controller scheme have shown effective, secure, and stable performance with field trials in planning.

References

- [1] “Catching Falling Conductors in Midair – Detecting and Tripping Broken Distribution Circuit Conductors at Protection Speeds”, W. O’Brien, E.A. Udren, K. Garg, D. Haes, and B. Sridharan, Georgia Tech Protective Relay Conference, May 2016.
- [2] “When Power Lines Break, a New Control System Keeps the Sparks from Flying”, Interview of W. O’Brien of SDG&E by P. Fairley, *IEEE Spectrum*, September 2018.
- [3] “WASA and the Roadmap to WAMPAC at SDG&E”, E.A. Udren and T. Rahman, CIGRÉ Grid of the Future Symposium, October 2019, Atlanta, GA.
- [4] Udren, E., “Principles for Practical Wide-Area Backup Protection with Synchrophasor Communications”, Paper B5-112, CIGRÉ 2014 General Session, Paris, France.
- [5] Udren, E., Bolton, C., Dietmeyer, D., Rahman, T., Flores-Castro, S., “Managing Wildfire Risks”, *IEEE PES Power and Energy Magazine*, January-February 2022.

Biographies

Tariq Rahman is a Principal Engineer in the Electric Engineering Department at San Diego Gas & Electric Company (SDG&E), California. He obtained his BSEE in 1980 and MSEE in 1985. Tariq has 35+ years’ electric utility industry working experience in Electric Grid Control Room Operations, Generation Planning, and System Protection & Control Engineering. Tariq has been leading SDG&E’s Transmission Synchrophasor-based Wide Area Situational Awareness (WASA) project since 2010. In 2017 his effort and the accomplishment of SDG&E has earned him the NASPI “Synchrophasor Technology Champion” award, and SDG&E the “NASPI 2017 Outstanding Utility” award. Tariq led the development of an advanced Visualization Software System (VSS) for SDG&E’s next generation WASA system (WASA2) that is currently being commissioned in SDG&E’s Grid Control Room for real-time operations complementing the EMS system. Tariq also led SDG&E’s transition from TDM/SONET to MPLS communication for teleprotection, WASA/WAMPAC systems and SCADA. He has been presenting at many protective relay conferences, NASPI, NERC SMS, WECC JSIS, IEEE and SMART conferences and working groups. He is a licensed Professional Engineer in the states of New York and California and is a Senior Member of IEEE.

Chris Bolton joined San Diego Gas & Electric in 2011 as an Associate Engineer, landing in Substation Engineering as his first permanent assignment. There he worked on the Capital Projects Team, managing and providing engineering support for various greenfield and brownfield electric substation and synchronous condenser installations. In 2016, Chris transferred to the Substation Technical Analysis & Support team at Kearny Maintenance and Operations where he managed the construction and commissioning of various greenfield and

brownfield electric substation and synchronous condenser installations. Chris then took a position as Team Lead in System Protection Maintenance where he supervised Relay Technicians responsible for installing, commissioning, and maintaining SDG&E's electric substation control and protection infrastructure. Most recently, Chris has assumed the position of Manager of System Protection Automation & Control Engineering where he now oversees the engineering of all SDG&E control and protection / automation equipment for electric infrastructure. Chris graduated with a bachelor's degree in Electrical Engineering from California State Polytechnic University, Pomona and is a Licensed Professional Engineer in the State of California.

Eric A. Udren has a distinguished 53-year career in design and application of protective relaying systems, substation control, IEC 61850, wide-area monitoring and control systems, PMU applications, and communications systems. He works with major utilities to develop new substation protection, control, communications, and remedial action scheme designs based on Ethernet, IEC 61850 integration, and synchrophasor techniques. Since 2008 he has served as Executive Advisor with Quanta Technology, LLC of Raleigh, North Carolina; with his office in Pittsburgh, Pennsylvania. Eric is Life Fellow of IEEE, and twice served as Chair of the Relaying Communications Subcommittee of the IEEE Power System Relaying and Control Committee (PSRC). He is Technical Advisor to the US National Committee of IEC for TC 95 relay standards; and is SME member of NERC System Protection and Control Working Group (SPCWG). He has written and presented over 100 technical papers and book chapters and holds 12 patents. Eric appeared as PACworld Magazine Industry Guru in September 2016. In 2019 Eric was elected to the US National Academy of Engineering 'for leadership in advancing protection technologies for electric power grids.'