

Types of System Oscillations and Their Detection - Concepts and Applications

Jason Byerly
American Electric Power

Zhiying Zhang
GE Grid Solutions

Mark Adamiak
Adamiak Consulting

I. Abstract

Oscillations on the power system represent an exchange of real or reactive power between entities on the grid or quantities induced onto the grid or as the result of a resonance. Due to the electromechanical make-up of the grid, oscillations have existed from the beginning of power system time. In the beginning, the primary source of oscillations was machine-to-machine hunting – resulting in what is known today as Inter-Area Oscillations. As the power system has grown and expanded into new realms, the sources and frequencies of oscillations have expanded and has been classified by NERC as Forced Oscillations. Yet another type of oscillations is torsional/subsynchronous mode oscillations, happening due to interaction of the turbine-generator or wind farms with the series-compensated lines.

All these oscillations have different effect on the power system and have different frequency ranges, but reality is that it's important that all of them can be detected. Many utilities including AEP have experienced a number of subsynchronous oscillations on the transmission network forcing the need to detect these conditions in real-time to mitigate possible effects of poorly damped oscillations.

This paper first identifies a set of ranges of sub-synchronous oscillations, introduces a new high-performance measurement technique for these oscillations, and identifies possible mitigation strategies. It illustrates detection of system oscillations using real system events recorded in AEP system.

II. Oscillation Definition

Oscillations can be characterized by:

- Frequency
- Magnitude
- Synchro Angle
- Damping constant

In the example in Figure 1, one can see examples of both Positively (Figure 1a) and Negatively (Figure 1b) damped oscillations. The August 10, 1996 Western US system breakup has been attributed to negatively damped electromechanical oscillations on the grid₃.

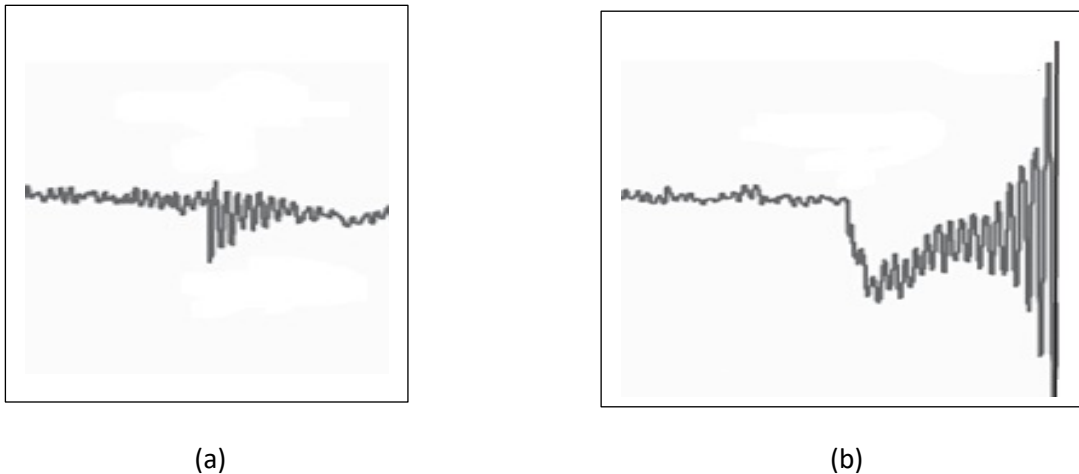

Figure 1. Positively damped oscillations (a), Negatively Damped Oscillation (b)

III. Sources and Ranges of Oscillations

Oscillations in power system are caused by the interaction of different power system components with each other, usually happening after system disturbances and system re-configuration. A new class of oscillations termed Forced Oscillations has been identified by NERC. Forced oscillations are driven by external inputs to the power system and can occur at any frequency.

Oscillations can be classified by certain types, with each type exhibiting a certain range of the oscillation frequency when this phenomenon occurs. These major types are as follows:

- Local plant mode oscillations- happen when some generators are oscillating against the rest of the power system with a characteristic frequency of 1-2Hz
- Inter-area mode oscillations happen when generators in the one part of the system are oscillating against other generators in another part of the system. Characteristic frequency of inter-area oscillations is 0.1Hz to 1Hz.
- Torsional mode oscillations- happen due to interaction of the turbine-generator mechanical system and with a system, connected through the series-compensated line. Characteristic frequency of interarea oscillations is 10Hz to 46Hz.
- Control mode oscillations - happen due to poorly tuned exciters, governors, HVDC converters, Static Var Compensators, large wind farm connections to the system. Frequencies here range from 1 to 15 Hz

The following taxonomy of ranges of oscillations on the power grid are proposed:

- a. DC to 0.01 Hz – this range is designed to capture the “almost” DC component of Geomagnetically Induced Currents (GIC). GIC currents result from the coupling of solar storm particles with power lines. Note that DC Coupled current and voltage sources are available as inputs to oscillation calculations
- b. 0.01Hz to 0.1Hz – this is the expanded GIC range
- c. 0.1Hz to 1.0Hz – this range captures the inter-area oscillations
- d. 1.0 to 10Hz – this is the “new” range identified by NERC as the Forced Oscillation₁ range which captures most of the control mode oscillations
- e. 10 Hz to 55 Hz – this range is known as the Sub Synchronous Oscillation range – typically resulting from resonance of series capacitors with the power system. Forced oscillations can also occur in the lower end (10 to 15 Hz) of this range

IV. Detection and quantification of Oscillations

Oscillations appear on the grid as a modulation of the fundamental frequency voltage and current signals – much like an AM Radio transmission. Often time, voltages and currents are integrated in a device and combined to create sequence components (phasors), and real and imaginary power values. When fundamental frequency values are converted to power, the resulting values are typically a straight line (as shown in Figures 1a and 1b).

There are several mechanisms that have been used in the industry for the extraction of oscillations_{2,3} - many of which use Synchrophasors. Although Synchrophasor analysis can roughly identify oscillation modes, it does take an appropriately sized window (based on the oscillation frequency of interest) to capture the data needed for analysis – which adds latency to the calculation. Additionally, Synchrophasors cannot be used for high-frequency analysis – especially for oscillation frequencies greater than 30 Hz due to the window size of the Synchrophasor. Of note, for P-Class Synchrophasors have a 2-cycle integration window which limits them to oscillation measurements of less than 15 Hz; M-Class Synchrophasors have up to an 11 cycle window which limits them to oscillation measurements of less than 3 Hz.

A new approach for the extraction of oscillation information is proposed – one that uses RMS signals such as Voltage, Current, and Power for lower frequency signals and the signal sample data for the extraction of the higher-order frequencies from 10 to 55 Hz. On lower frequency signals, High Pass (to remove DC components) and Low Pass (for smoothing) filters are applied to the input signal. On higher frequency signals (10 Hz to 55 Hz), a digital filter bandpass filter can be applied to the sample data to remove the fundamental frequency component of the samples – leaving the raw oscillation signal (see Figure 2 – red trace). The resulting oscillation signal can then be analyzed in the same manner as combined signals which is by passing the resulting oscillation waveform through digital High and Low Pass filter resulting in the MAGENTA trace in the middle graph in Figure 2. From this signal, the frequency and magnitude of the oscillation can be computed.

This algorithm enables high-speed of identification of an oscillation. In the bottom graph in Figure 2, we see the green trace which is labeled as the Validation Flag. For a 10 Hz oscillation (which has a

period of 100ms), it can be seen that the Validation Flag is set in about 53ms – about half the period of the oscillation.

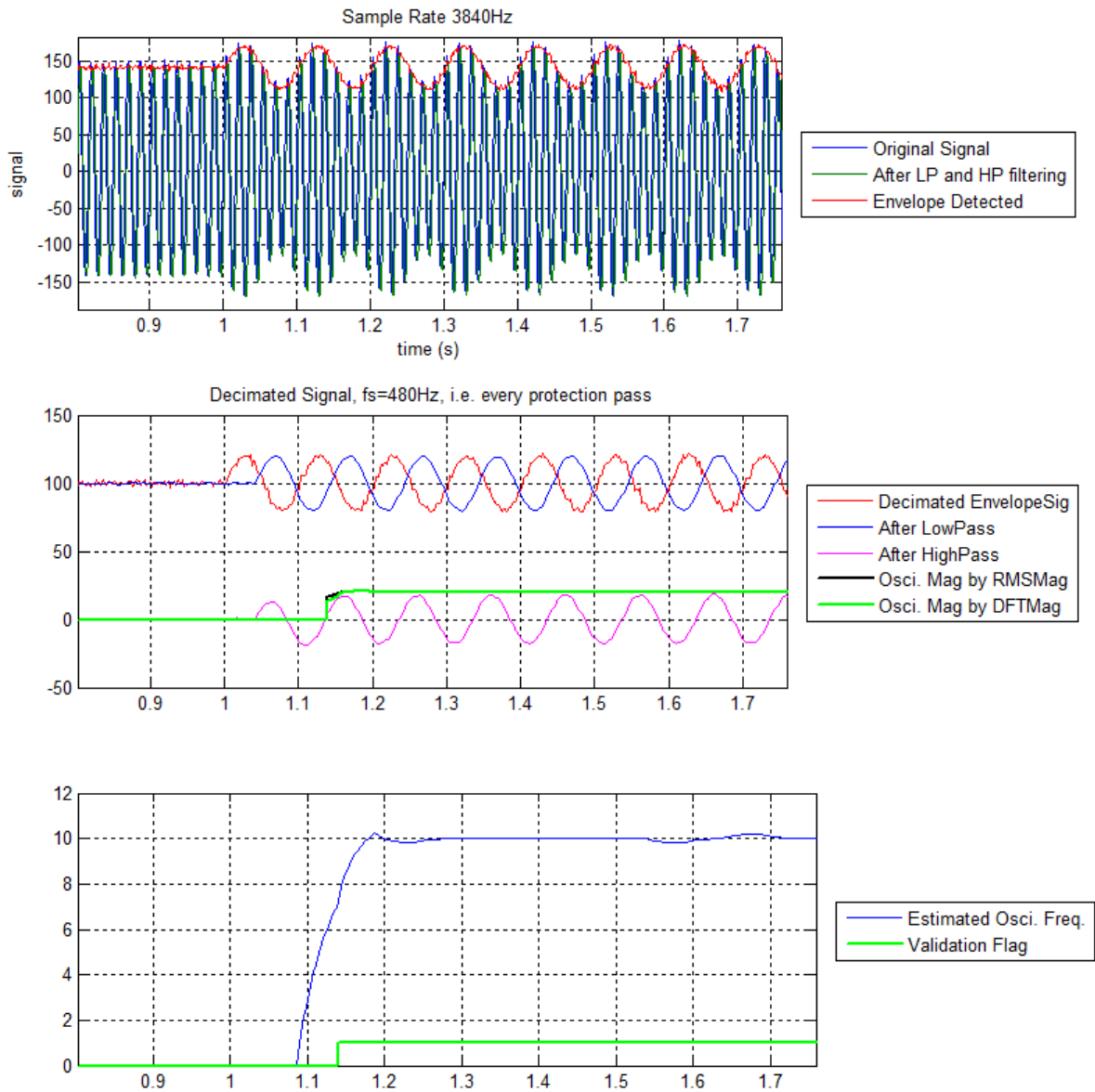

Figure 2. Demodulation Process, Frequency Detection, and Oscillation Validation of a 10 Hz Oscillation

The computed magnitude from the Discrete Fourier Transform (DFT) of the oscillation can be checked against absolute limits or it can be compared to an Inverse Time curve such that larger magnitude oscillations can result in an output quicker and lower magnitude oscillations can take longer to respond.

A given oscillation can have 3 different decay modes, namely: Positively Damped (the oscillation is diminishing), Undamped (neither growing or diminishing), and Negatively Damped (the magnitude of the oscillation is increasing). Most oscillations on the grid are damped, meaning that as time goes on,

the oscillation lessens in magnitude – as in Figure 1a. A negatively-damped oscillation is just the opposite wherein the oscillation grows in magnitude over time as in Figure 1b; an undamped oscillation is where the oscillation neither decreases nor increases over time. The oscillation signal can be modeled by equation 1:

$$y(t) = \sqrt{2}A(1 + m \cdot e^{\sigma(t-t_0)}) \cdot \sin(\omega_m(t - t_0)) \cdot u(t_0) \cdot \sin(2\pi f_1 t) \quad \text{Eq. 1}$$

Where A is the magnitude of the sinusoidal signal, f_1 is the system frequency, ω_m is the angular frequency of the modulating signal (this is the oscillation frequency that will be estimated), m is the magnitude of the modulating signal (in fraction of magnitude A, note that “m” is the oscillation magnitude to be estimated), σ is the exponential growth (or decay) rate of the modulating signal, $u(t)$ is the step function, i.e. when $t > t_0$, the oscillation starts.

The damping ratio of this oscillation signal is defined per Eq. 2:

$$\xi = \frac{-\sigma}{\sqrt{\sigma^2 + \omega_m^2}} \quad \text{Eq. 2}$$

When σ is a negative number, the damping ratio is positive which means that the oscillation is damped, i.e. the oscillation magnitude will get smaller with time; when σ is a positive number, the damping ratio is negative which means that the oscillation is negatively-damped, i.e. the oscillation magnitude will get larger with time.

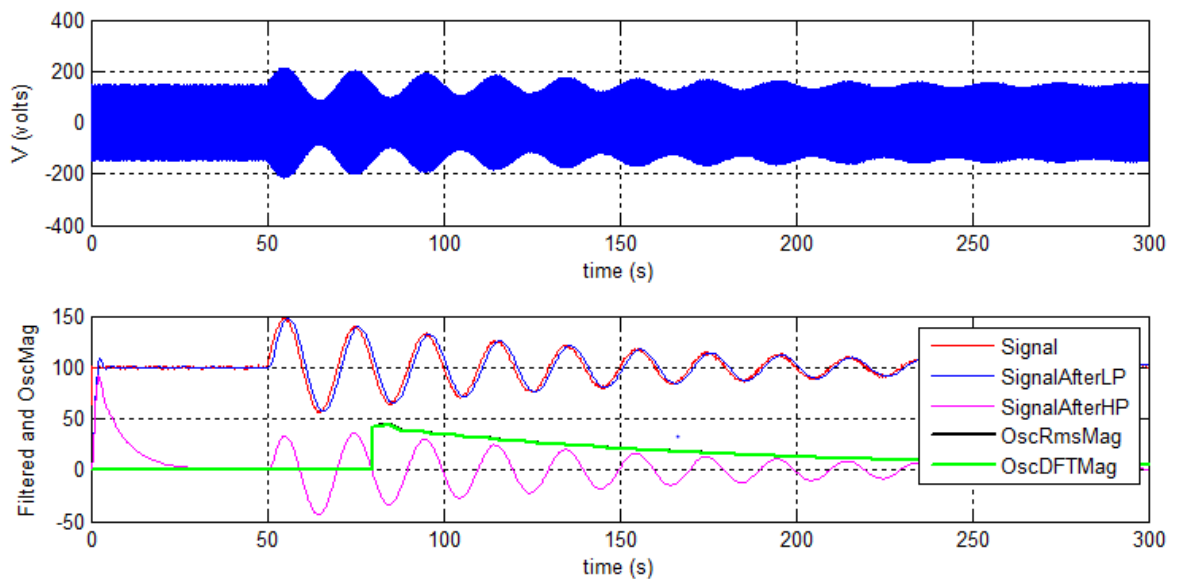

Figure 3. Positively Damped .05Hz Oscillation

IV. Synchro Oscillation Angle

Similar to fundamental frequency signals, an oscillation signal has a Synchrophasor – which is the Magnitude and the Angle of the oscillation at the oscillation frequency. The computation of the

Synchro Oscillation phasor is possible since the sample values used in the oscillation analysis are time stamped to absolute time. Of significance is the fact that the Synchro Oscillation Angle can be used to identify “groups” of generators that are oscillating with other “groups” of generators. The identification of which groups of generators are oscillating with which other groups of generators can then be used to damp inter-area oscillations. One can visualize this concept through the analogy of a see-saw. At any instant in time, when one end is up, the other end is down. The Synchro Oscillation Angle can be visualized as the angle between a measurement at each power plant and some reference point (which is the horizontal axis in Figure 4).

In the implementation proposed above, in as much as the processed signals are passed through digital filters, without removal of the phase shifts resulting from these filters, the Synchro Angle will only align on devices with similar digital filters.

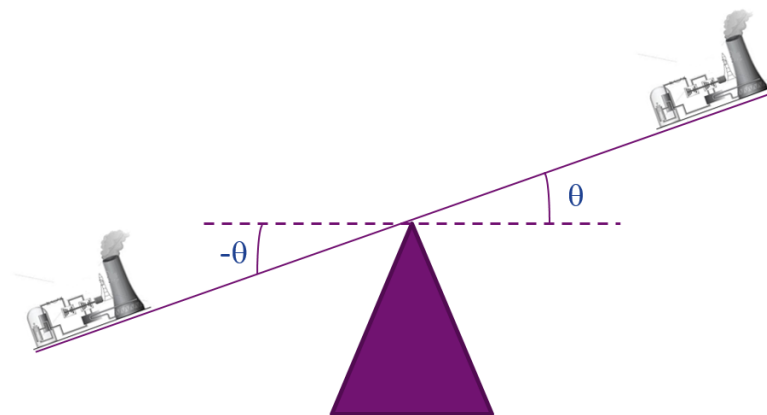

Figure 4. Synchro Oscillation Angle Visualization

V. Application of Oscillation Detection

The application of oscillation information can take two paths in the power system, namely, situational awareness and Remedial Action. For situational awareness, the information from the various oscillation bands (frequency, magnitude, damping constant, synchro oscillation angle) at all locations on the grid can be mapped into a SCADA system via protocols such as Modbus, DNP, IEC 60870, and IEC 61850 and then mapped into Energy Management System displays as appropriate. One example would be showing a moving “power” bar between nodes or regions in a display to indicate power flows during inter-area oscillations. Operators viewing this information could act – via changes in power dispatch – to damp the power exchange. Additionally, identification of Geomagnetically Induced Current in a transformer could allow an operator to unload a transformer. One note – the IEC 61850 models for single frequency oscillations need to be defined and incorporated in the standard. An array of oscillations frequencies as one might get from a Fast Fourier Transform can be accommodated today but the semantics would not include features such as damping.

For faster reporting / response times, oscillation data can be included in a Synchrophasor stream – which can then be communicated at rates up to 120 messages per second. Mapping the data into a GOOSE/Routable-GOOSE message is another possibility and any changes detected by the oscillation detection process would initiate a launch of a GOOSE message.

Many times, such as during an unstable oscillation, there is little time for the operator to act. During this time, the result of an oscillation in a system can be configured to result in automatic action. An example of this is forced oscillations which occur in areas where there are high concentrations of inverter-based interfaces (i.e. – wind farms) which are interfaced to transmission lines. Resonance conditions have been observed between the inverter-based generation and series capacitors on the transmission line. An oscillation monitoring system could, upon detection of a specific frequency range and oscillation magnitude, dynamically implement controls such as bypassing of the series capacitor.

VI. Field cases

Case #1

On August 24th, 2017 in AEP 345 kV system, a personnel error at station E, shown in Figure 5, caused an erroneous DTT signal to be sent to station D, resulting in opening of the line D-E. This event caused the windfarms (shown as WF B and WF C) connected to station D to become connected through the station D to station C line in series with the in-service series capacitor banks shown below.

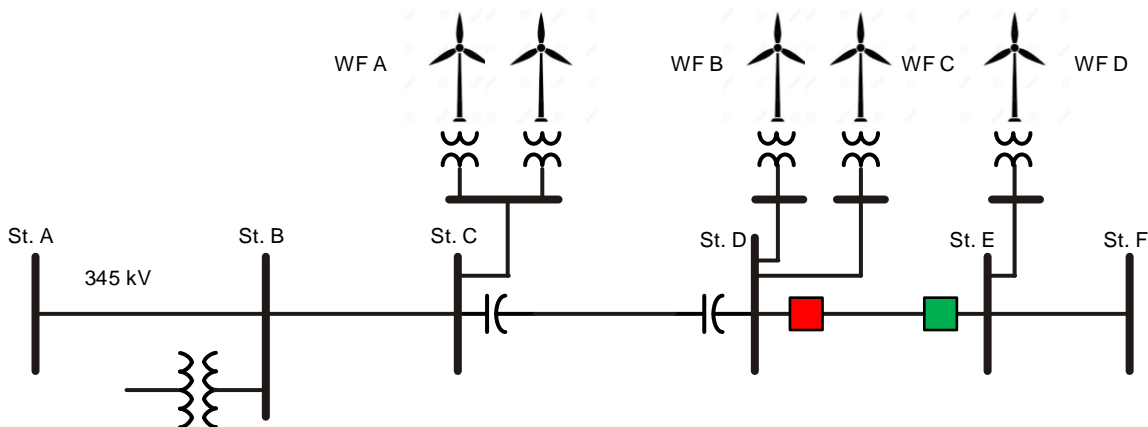

Figure 5. Case #1 single line diagram

Approximately 0.3 seconds after the opening of the line between the two stations due to the DTT, the Figure 6 oscillography was recorded on the line relaying at station D towards station C line relaying. After nearly 2 seconds of steady state conditions, similar to that shown in Figure 6, the series capacitors which were both initially in service bypassed automatically on protective trip of subsynchronous overcurrent function.

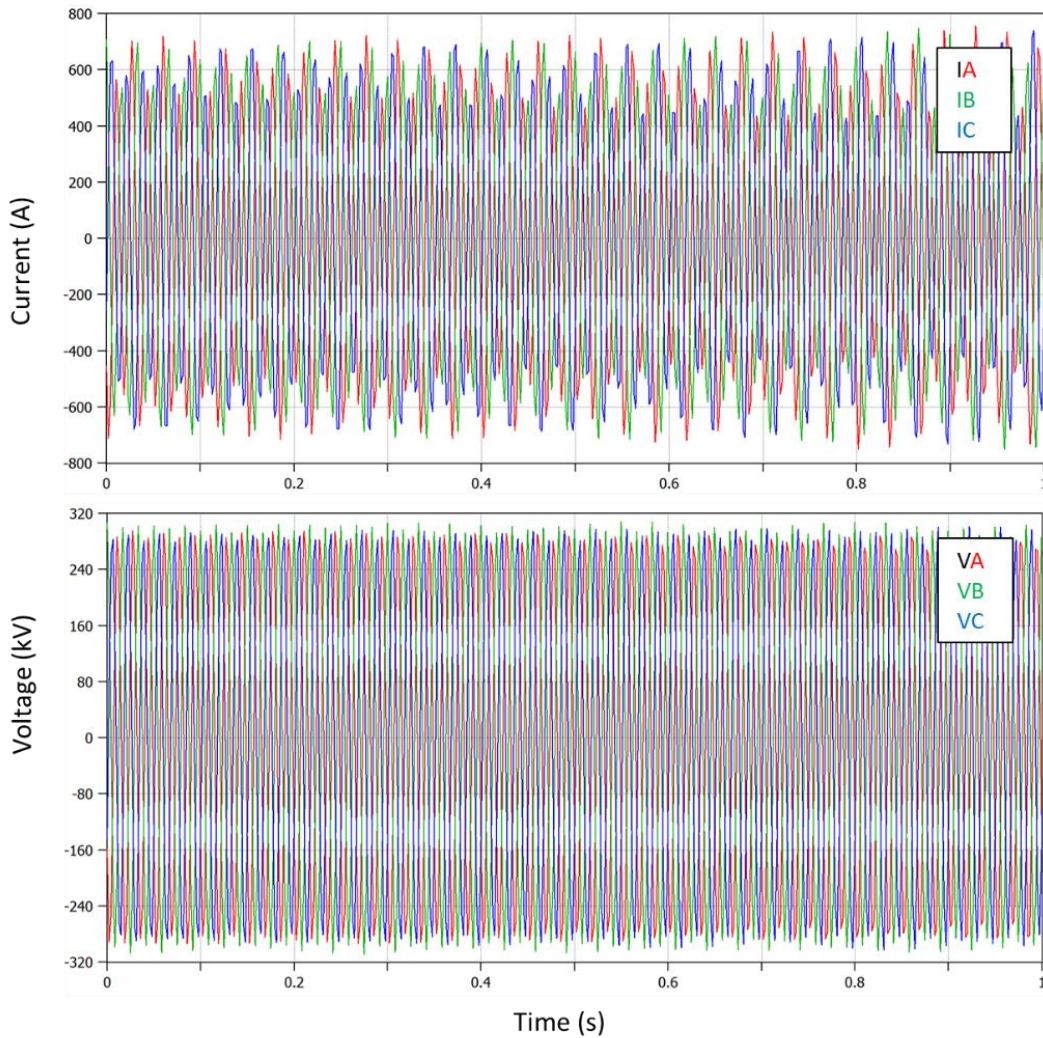

Figure 6. Case #1 currents and voltages at station D after line D-E trip

Algorithm (MSOD – Multi Range Oscillation Detection) described above is used to detect and measure oscillation for this system event.

The settings of the MSOD element are shown Figure 7 below. First of all, frequency oscillation band where oscillation can occur is selected. Secondly signal used to detect oscillations is selected, which depends on the available signal from the instrument transformers. When frequency is detected within this band, algorithm will report exactly measured frequency. Separate alarm and trip pickup settings are provided to initiate a desired action once oscillation magnitude exceeds the threshold. Alarm and trip delay is provided as well.

Oscillation damping supervision is optional and can be enabled or disabled. If enabled, then damping ratio has to be properly selected.

SETTING	PARAMETER
MSOD 1 Function	Enabled
MSOD 1 FreqBand	BAND 4
MSOD 1 Source	SRC 1
MSOD 1 Input Signal Band 4	IA
MSOD 1 Low Freq Band 4	15.00 Hz
MSOD 1 High Freq Band 4	45.00 Hz
MSOD 1 Alarm Pickup	0.10 pu
MSOD 1 Trip Pickup	0.20 pu
MSOD 1 Deadband	0.02 pu
MSOD 1 Alarm Delay Band 4	0.10 sec
MSOD 1 Trip Delay Band 4	0.20 sec
MSOD 1 Damping Ratio Superv	Enabled
MSOD 1 Damping Ratio Level	0.1 pu
MSOD 1 Oscillation Phase Offset	0.0 deg
MSOD 1 Block	OFF
MSOD 1 Events	Disabled

Figure 7. MSOD settings, band #4 15-45 Hz used for case #1

To measure precisely synchro-angle, a phase offset setting is provided which allows the user to calibrate the input source to offset the phase errors introduced by VTs, CTs, cabling or connections (such as polarity or vector group configurations).

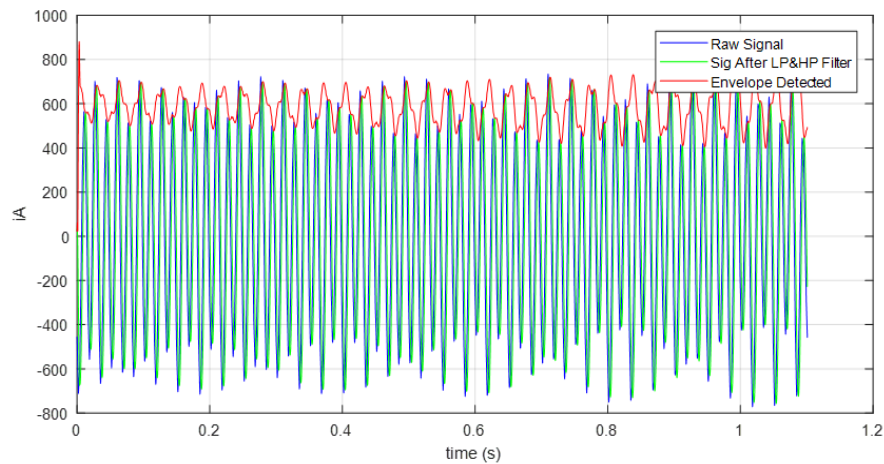

Figure 8. Raw IA signal and oscillation envelope of the signal

Once signal oscillation is detected and validated per settings, it's considered measurable. Algorithm measures magnitude and frequency of oscillation. Figure 9 below is showing that signal was detected valid at about 0.2s in the plot and measured filtered frequency of 32.36Hz.

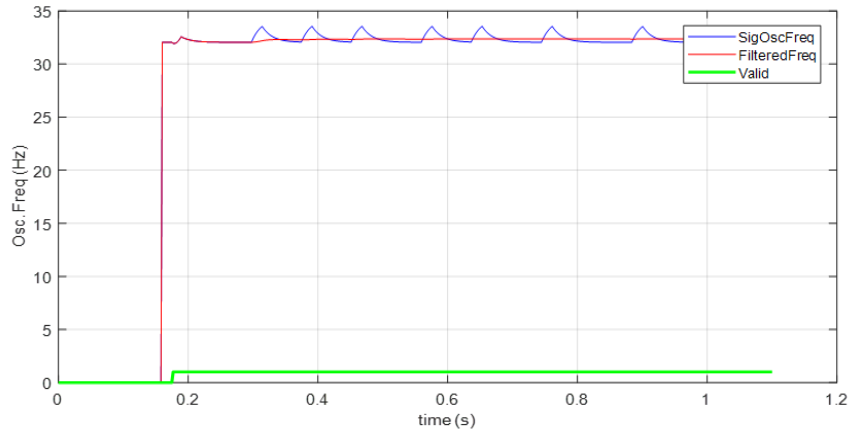

Figure 9. Filtered oscillation frequency from IA signal

Further algorithm detects the damping ratio, which in this case was around -0.3%, i.e. negatively damped, indicating that the magnitude of the oscillation is increasing with time and proper remedy actions, such as bypass series capacitors, must be taken to mitigate the oscillation before it endangers equipment or system.

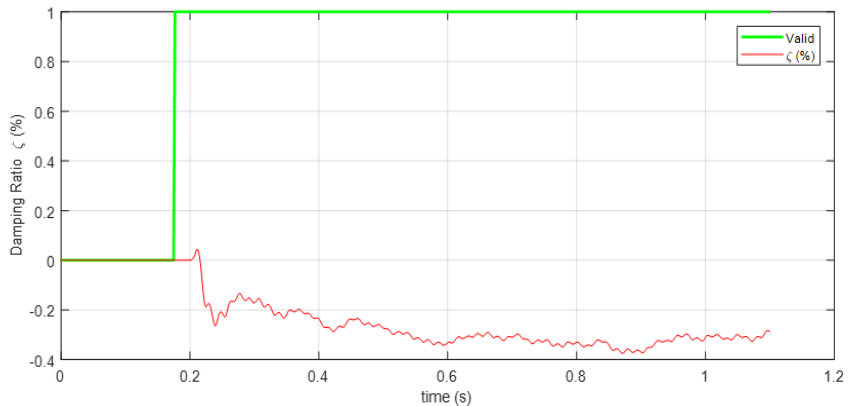

Figure 10. Measured damping ratio from IA signal

It is not shown here but should be noted that using voltage as an input signal gives very close oscillation frequency estimation at 32.45Hz and very close damping ratio of -0.3. It implies that both current and voltage can be used to detect oscillations.

Nearly 20 minutes passed, and dispatch personnel manually reinserted the two series capacitors on the line C-D, at nearly the same time. This manual re-insertion caused significant distortion in both voltages and currents and significant oscillations observed in the Figure 11 below. Significant overvoltage, peaking above 600kV in each phase, which is higher than 2.1 times normal phase voltage, caused tripping of the WF B and WF C windfarms. Isolation of these windfarms stopped oscillations and returned voltage back to normal.

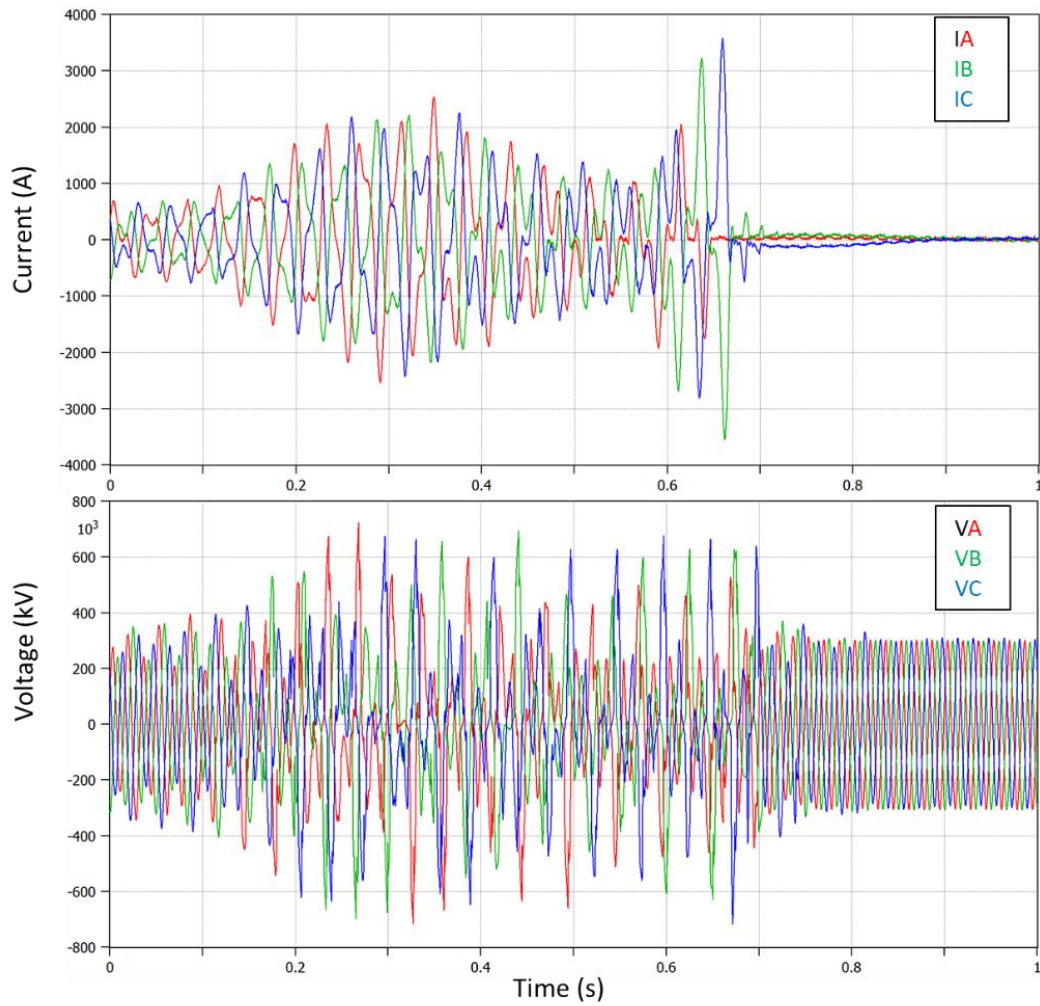

Figure 11. Case #1 currents and voltages at station D after line D-E series-capacitors re-insertion

Analysis of the second wave of oscillations is demonstrated below using VA signal.

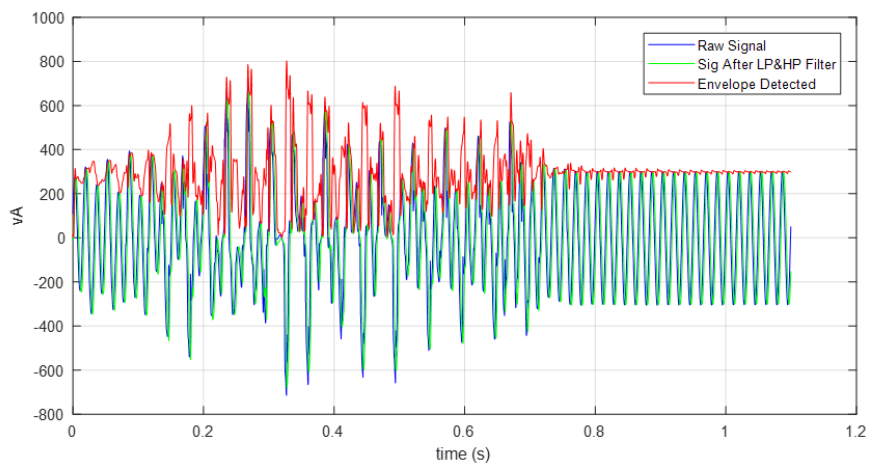

Figure 12. Raw VA signal and oscillation envelope of the signal

Figure 13 below is showing that signal was detected valid at about 0.2s in the plot and measured filtered frequency of close to 35 Hz.

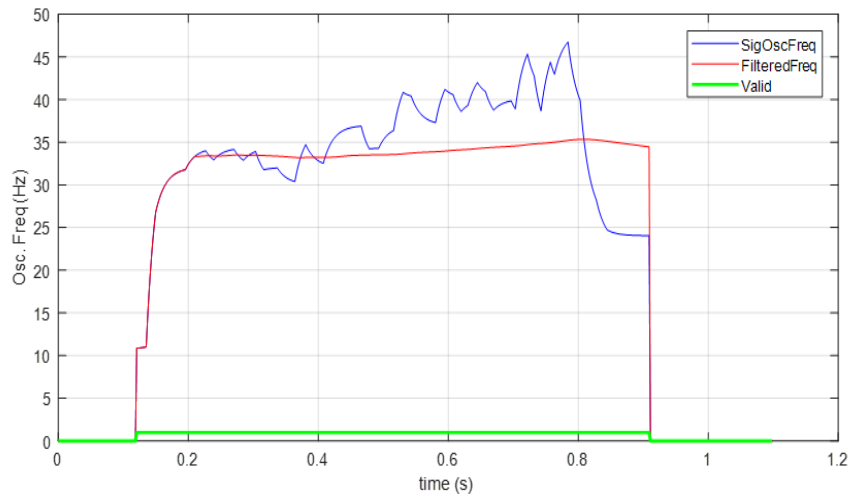

Figure 13. Filtered oscillation frequency from VA signal

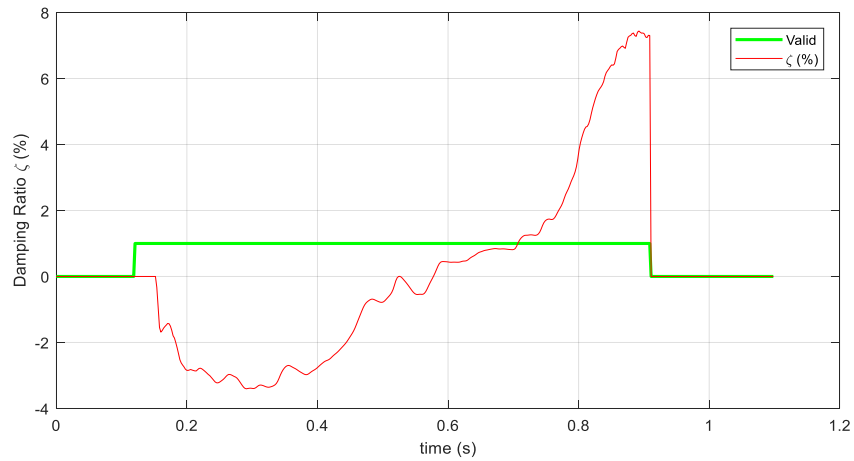

Figure 14. Measured damping ratio from VA signal

From the Figure 14 it can be seen that damping ratio turns from negative to positive at 0.65s indicating that the system changed from the initial unstable oscillation to a stable oscillation after WF B and WF C were removed from the system. .

Case #2

On October 27th, 2017 in AEP 345 kV system, an AG fault between stations D and E, caused this line trip. After line D-E trip the windfarms (shown as WF B and WF C) connected to station D to become connected through the station D to station C line in series with the in-service series capacitor banks shown below. This caused oscillations, recorded on the line C-D and windfarms WF B and WF C, which subsided sometime later.

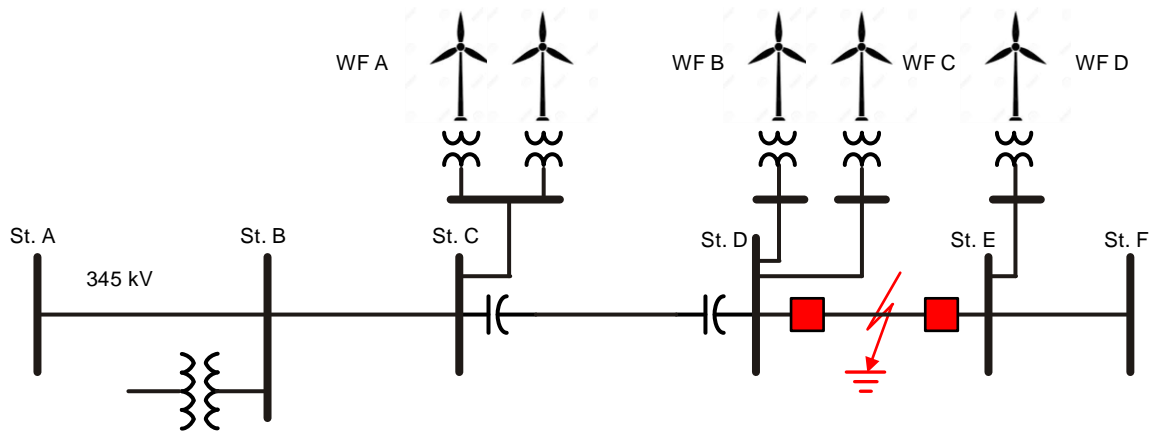

Figure 15. Case #2 single line diagram

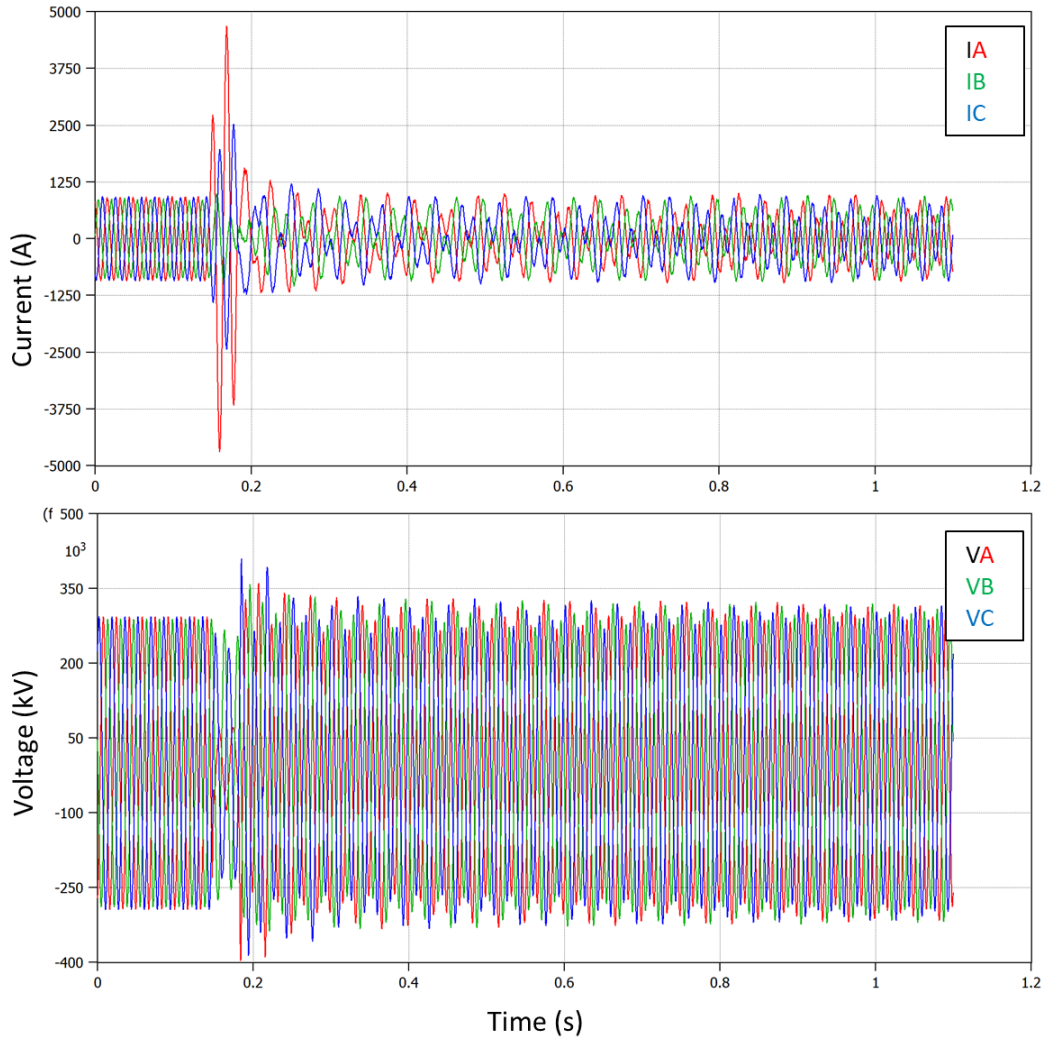

Figure 16. Case #2 oscillation on the line C-D after line D-E trip

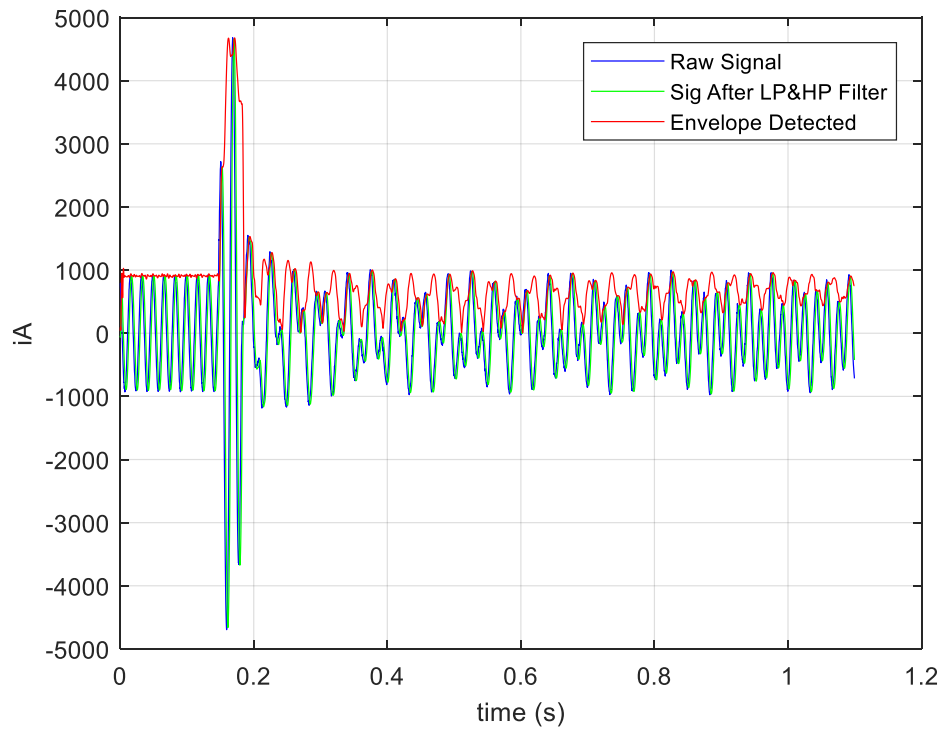

Figure 17. Raw IA signal and oscillation envelope of the signal

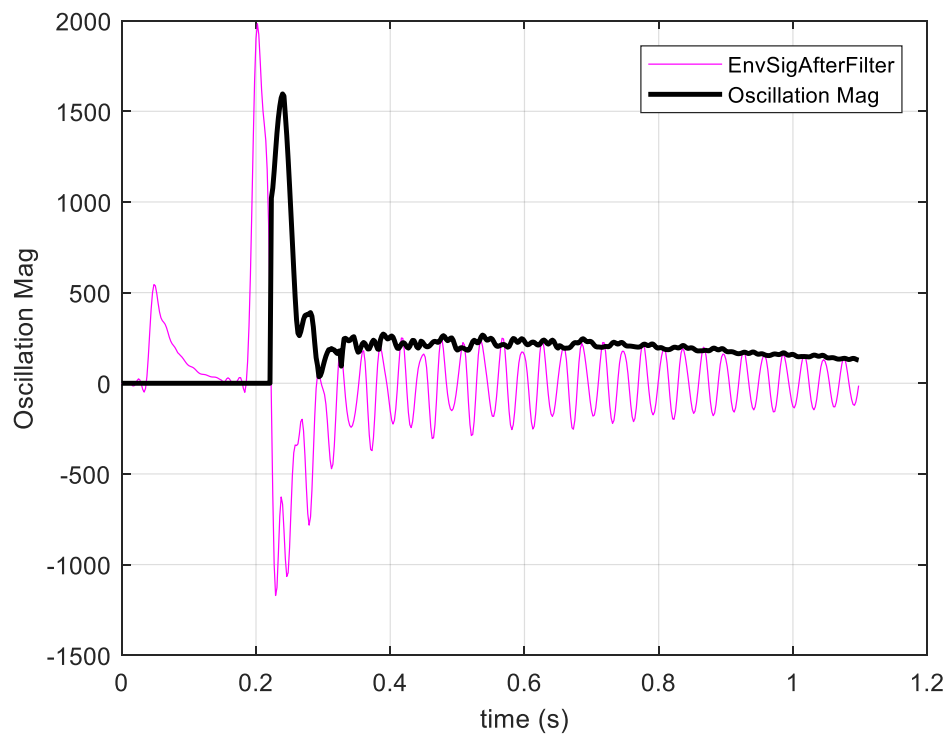

Figure 18. IA signal oscillation magnitude

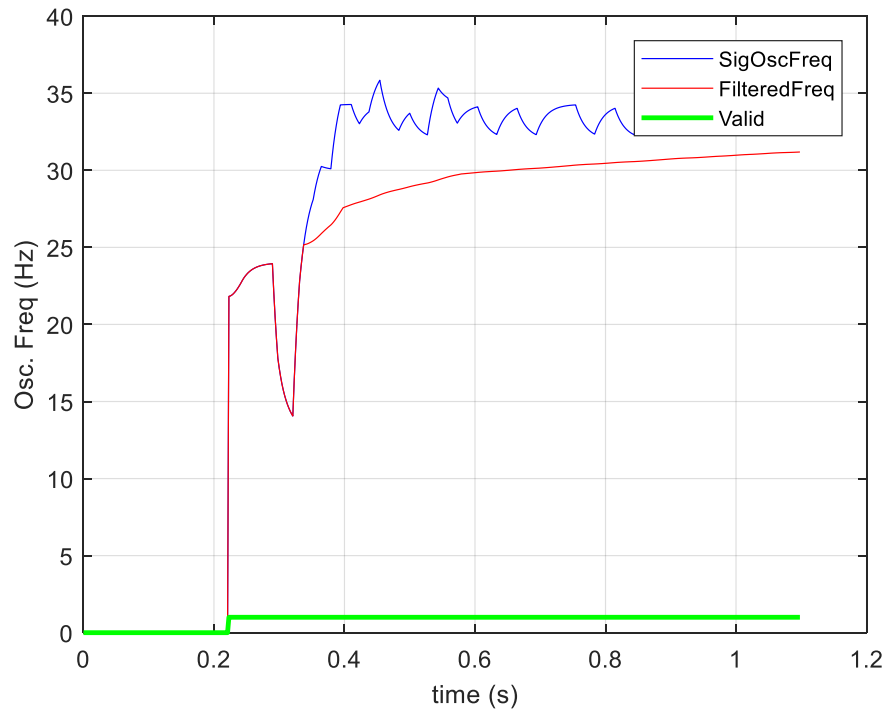

Figure 19. Filtered oscillation frequency from IA signal

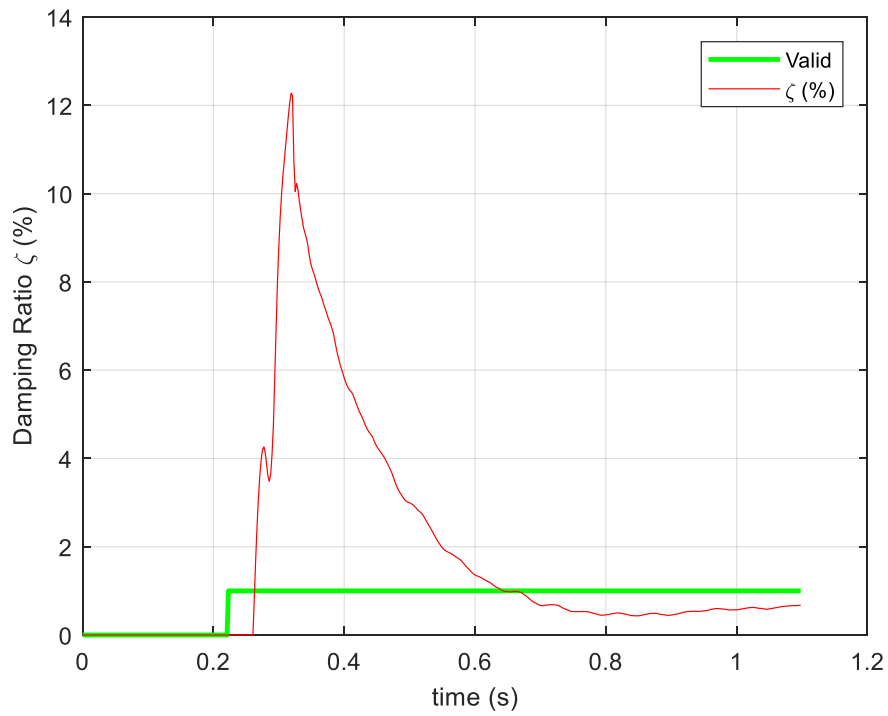

Figure 20. Measured damping ratio from IA signal

From the Figure 19 it can be seen that oscillation frequency was measured nearly 30Hz and from the Figure 20 can be seen oscillation was positively damped, in which the magnitude of the oscillation is decreasing with time . Note that the reason that the damping ratio was measured with a large value initially was because partial of the fault current was actually included in the oscillation magnitude calculation due to filter effect as shown in Figure 18. Approximately 3 minutes after line D-E trip, line was manually reconnected to the system, restoring the transit. Sub synchronous oscillation started again.

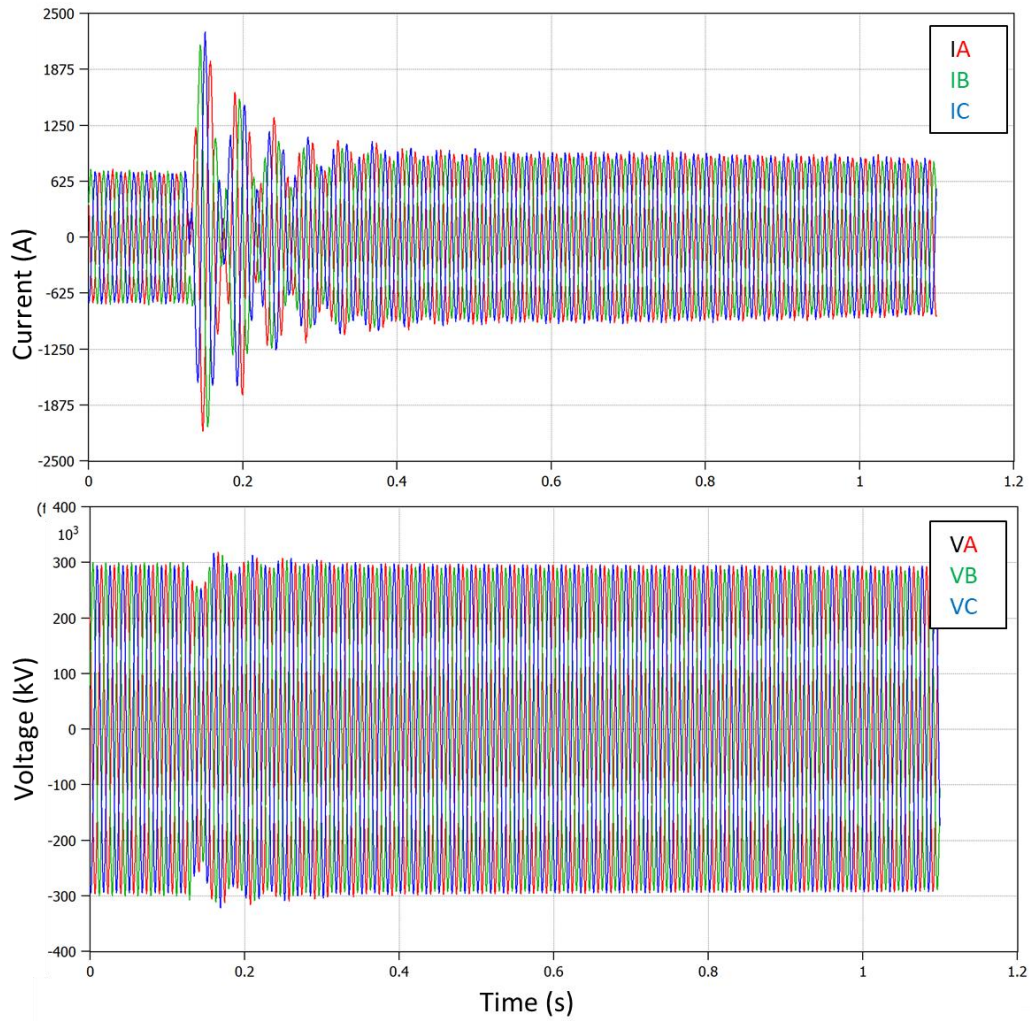

Figure 21. Case #2 oscillation on the line C-D after line D-E manually reclosed

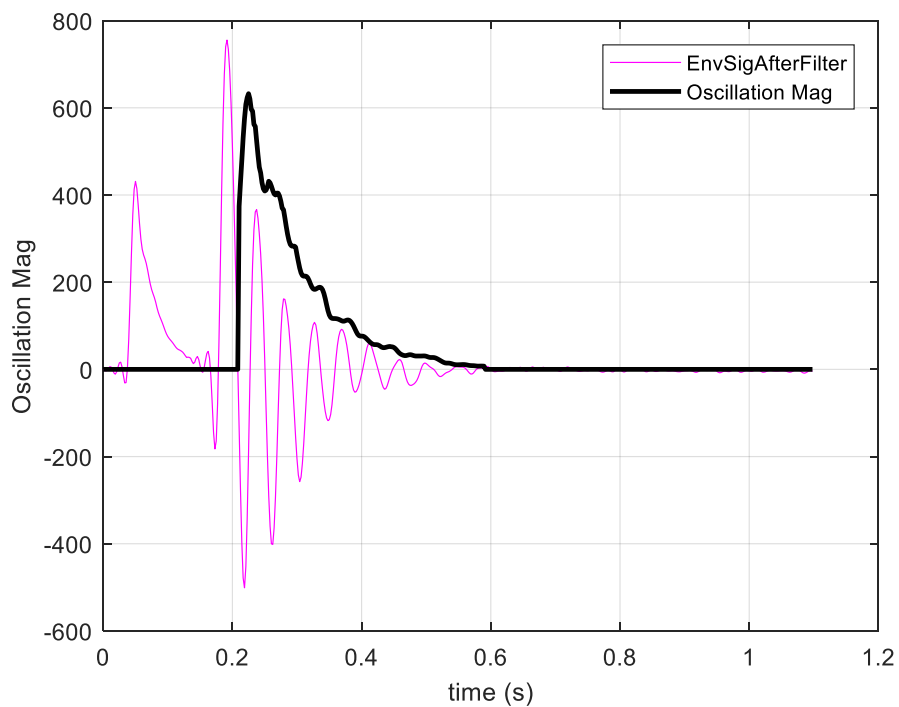

Figure 22. IA signal oscillation envelope and magnitude

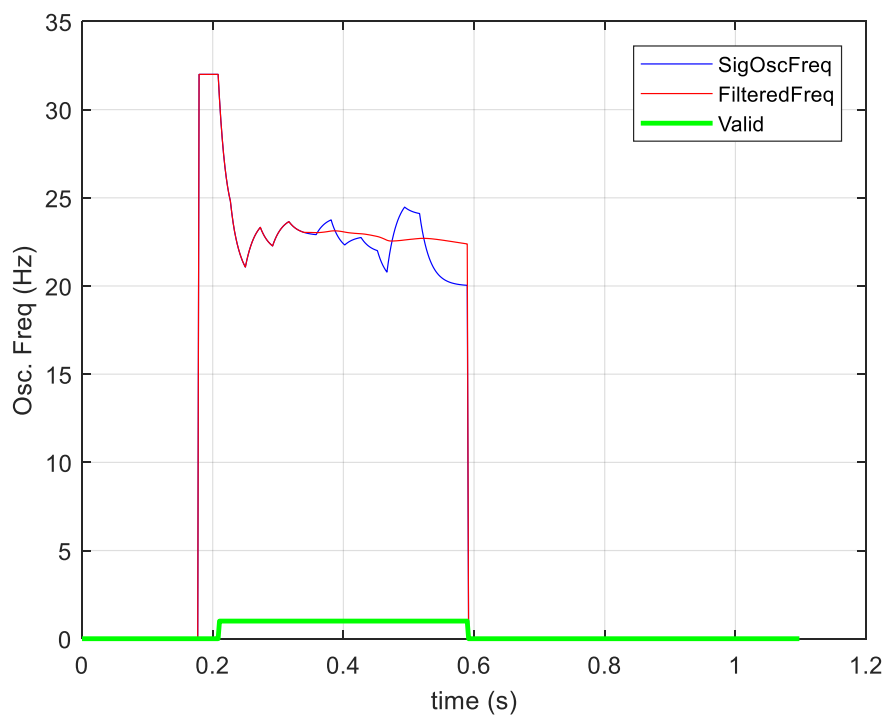

Figure 23. IA signal oscillation frequency

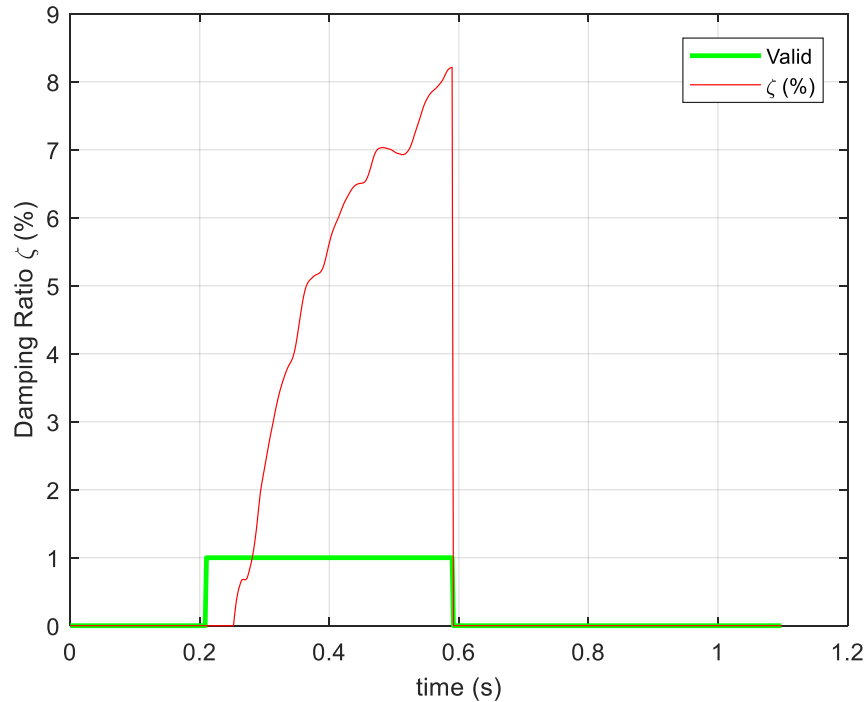

Figure 24. Measured damping ratio from IA signal

From the Figure 23 it can be seen that oscillation frequency was measured at around 23Hz and from Figure 22 it can be seen that the measured oscillation magnitude rapidly decreased, which was indicated with a large positive damping ratio as shown in Figure 24. Because of the rapid damping, in about 0.4 seconds after the D-E line was reconnected, the system returned to normal.

VII. Conclusions

Oscillations exist on the grid due to the electromechanical nature of the electric power grid as well as forced from external controls. In general, these oscillations are well damped and not an issue. High-energy oscillations can be unstable and do need to be mitigated before they can result in system instabilities. Today's digital sampling technologies are capable of detecting such oscillations and instabilities, reporting them for situational awareness, and are able to take immediate remedial actions to mitigate effects from the oscillations.

From the field oscillations experienced at AEP network, we can see that connections of the windfarms to the system are presenting prominent problem. Many oscillations today are unnoticed until major trip occurs. Digital relays today are capable to detect oscillations along with performing protection functions. Early detection of oscillations can help mitigating bigger problems later.

Different measured parameters can be used for oscillation detection, such as phase current or voltage, sequence components, real or reactive power and others. Also simultaneous oscillations in different frequency bands can be detected using separate element. Once oscillation is detected, it will be

recorded and major oscillation parameters will be reported such as, frequency, magnitude, synchro-angle and damping ratio. Action can be initiated as well to stop oscillation.

VIII. References

1. NERC Reliability Guideline, "Forced Oscillation Monitoring and Mitigation", 2017 Draft Oscillation Detection; NERC.COM;
https://www.nerc.com/comm/PC_Reliability_Guidelines_DL/Reliability_Guideline_-_Forced_Oscillations_-_2017-07-31_-_FINAL.pdf
2. NASPI publication, "Using Synchrophasor Data for Oscillation Detection"
https://www.naspi.org/sites/default/files/reference_documents/crstt_oscillation_detection_20180129_final.pdf
3. "Oscillation Detection Algorithm Development Summary Report and Test Plan"; PNNL-18945;
https://www.pnnl.gov/main/publications/external/technical_reports/PNNL-18945.pdf
4. The Electric Power Engineering Handbook; Edited by L.L. Grigsby; IEEE Press
5. GE publication GEK-134150A, "N60 Network Stability and Synchrophasor Measurement System", instruction manual, June 2020