

Case Studies of IEC 61850 Process Bus Systems Using GOOSE and Sampled Values: Recent Installations and Research

John Bettler

Commonwealth Edison Company

Jesse Silva

Southern California Edison

Dan Morman

Puget Sound Energy

Ricardo Abboud, David Bowen, Ed Cenzone, and David Dolezilek

Schweitzer Engineering Laboratories, Inc.

Presented at the

47th Annual Western Protective Relay Conference

Virtual Format

October 20–22, 2020

Case Studies of IEC 61850 Process Bus Systems Using GOOSE and Sampled Values: Recent Installations and Research

John Bettler, *Commonwealth Edison Company*

Jesse Silva, *Southern California Edison*

Dan Morman, *Puget Sound Energy*

Ricardo Abboud, David Bowen, Ed Cenzone, and David Dolezilek, *Schweitzer Engineering Laboratories, Inc.*

Abstract—This paper illustrates design and operational considerations for use when replacing elements of hardwired protective relay trip circuits with digital messaging via process bus networks based on IEC 61850 GOOSE, Sampled Values, and Precision Time Protocol. The paper introduces topology designs and process bus communications designs in use at Southern California Edison and Commonwealth Edison Company, as well as research being done at Puget Sound Energy.

The discussed operational considerations include cost, complexity, performance, testing, diagnostics, maintenance, data acquisition effects on equipment monitoring, carbon footprint reduction, trench replacement with conduit, and physical and cyber fault and threat avoidance and tolerance.

The paper introduces definitions and requirements produced by several technical standards development organizations in order to define acceptance criteria for process bus components and operation. Working Group K15 of the Substation Protection Subcommittee of the IEEE Power System Relaying and Control Committee has defined the terms *merging unit*, *remote input/output module*, *process interface unit/device*, and *intelligent merging unit*. IEC 61869-9:2016 has added two new conformance classes of merging units, bringing the total to four. These are consistent with the switchgear controller classes defined by IEC 62271-3:2006.

Finally, the paper considers replacing traditional field wiring with process bus technologies connected to relays that also perform station bus functions. A comparison is made based on the three most prevalent station bus topologies (performing interlocking and substation automation, SCADA, engineering access, and event retrieval) in use within thousands of IEC 61850 utility installations across many countries. The most prevalent topologies are used as the basis to compare and test three process bus scenarios added to relays used in the station bus designs. The three process bus designs are analyzed based on the impact to the substation when connected to a single line relay installed in a station bus network. The line relay station bus implementation remains a constant across all three process bus designs. The comparative analysis includes the performance, cost, complexity, resiliency, and security of devices used for process bus and station bus applications based on the IEC 61850 communications standard. Many similarities and differences are observed with the work done by the three utilities as well as unique considerations for adding new technology to existing designs.

I. INTRODUCTION

This paper presents the use of IEC 61850 methods to extend digital secondary systems from station bus applications (supervisory control and data acquisition [SCADA], interlocking, and engineering access) in the control building out into the substation yard among the primary equipment for process bus applications (protection and interlocking). This paper focuses on relays with station bus connections that support numerous protocols, such as IEEE 1815 (DNP3), Modbus, Telnet, File Transfer Protocol, and several IEC 61850 protocols. These relays simultaneously connect to a process bus using IEC 61850 Sampled Values (SV) messaging to receive digitized analog quantity measurements. IEC 61850 Generic Object-Oriented Substation Event (GOOSE) messaging sends and receives status and control messages, and IEC/IEEE 61850-9-3 Precision Time Protocol (PTP) receives time synchronization information.

The energy delivery system is a specialized industrial control system that delivers electricity to all points of consumption while satisfying customer quantity and quality requirements. The primary system (i.e., process components, including generators, transmission lines, and breakers) is monitored, protected, and controlled by an energy control system secondary system of digital devices and communications networks. The energy control system, like other industrial control systems, is best designed using defense-in-depth levels based on required applications, as illustrated in Fig. 1 [1]. This paper focuses on the devices installed within the process level among the primary equipment in the substation yard.

The Utility Communications Architecture (UCA) working group briefly considered bus topologies in the late 1990s, but they were replaced by direct connections and networks before the work was harmonized with IEC 61850. However, the terms “station bus” and “process bus” were coined at that time, and they are still used today to refer to different but overlapping groups of communications applications among power system intelligent electronic devices (IEDs).

Protocols that send operator control commands and transmit and receive system information use human-to-machine (H2M) connections to networked IEDs on the station bus. Engineering access, metering, monitoring, and SCADA are accomplished via automatic and human-activated client-server communications.

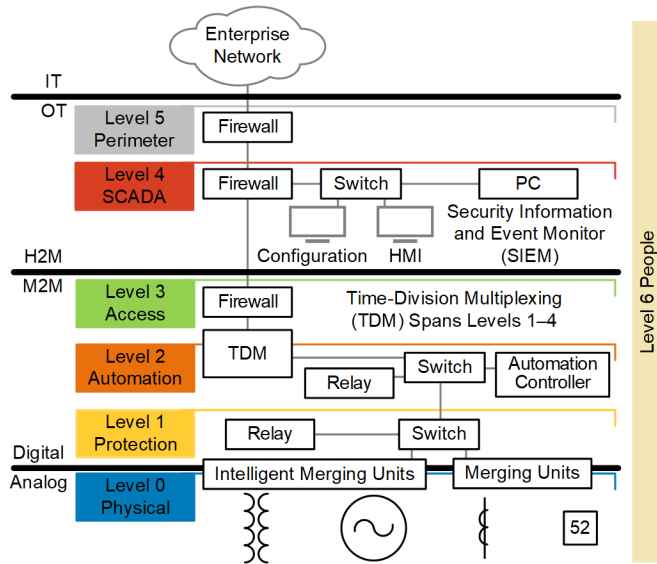

Fig. 1. Defense-in-Depth Levels Diagram [1]

Communications among instrumentation and control devices and IEDs within the specific industrial process of generating and distributing electric power are called process bus communications. These devices exchange energy delivery system I/O process information via machine-to-machine (M2M) connections and protocols between IEDs and process instrumentation and control devices, including data acquisition devices, instrument transformers, and controllers [2].

Protection, interlocking, and automation signal exchange and time distribution are accomplished on the station bus, process bus, or both via M2M communications among IEDs.

Numerous protocols are in use in modern energy control system networks for process bus communications and copper reduction strategies, including GOOSE and SV messaging, IEC 61158 EtherCAT, and IEEE C37.118.2-2011 Synchrophasor Protocol, PTP, and MIRRORING BITS® communications [3].

Energy control system designs must be economically feasible and satisfy the performance requirements for protection (i.e., reliability, security, speed, selectivity, and sensitivity) appropriate to the criticality and characteristics of each application [4].

II. INTERNATIONALLY STANDARDIZED PROCESS-LEVEL I/O DEVICE DEFINITIONS

Several international technical standard development organizations have created definitions of station bus and process bus components based on their intended purpose and capabilities.

A. IEEE PES Power System Relaying Committee

The “Centralized Substation Protection and Control” report is written by Working Group K15 of the Substation Protection Subcommittee of the IEEE PES Power System Relaying and Control Committee [5]. This report does not prohibit or endorse the use of specific protocols, but rather focuses on descriptions of devices and architectures for centralized protection and control (CPC) systems in the substation, as shown in Table I.

TABLE I
IEEE CENTRALIZED PROTECTION AND CONTROL DEFINITIONS

Device	Description
CPC system	“A system comprised of a high-performance computing platform capable of providing protection, control, monitoring, communication and asset management functions by collecting the data those functions require using high-speed, time synchronized measurements within a substation” [5]. The CPC is deployed as a standalone protection, automation, and control system.
Merging unit (MU)	“Interface unit that accepts multiple analog CT/VT [current transformer/voltage transformer] and binary inputs and produces multiple time synchronized serial unidirectional multi-drop digital point-to-point outputs to provide data communication.” [5]. IEEE considers MUs as devices that measure and digitize low-level energy field signals and publish messages that contain resulting binary statuses and/or raw analog signals to other IEDs. Many connections are possible, including private, point-to-point connections and time-synchronized, unidirectional Ethernet.
Remote I/O (RIO) module	“[The module] is intended to be the status and control interface for primary system equipment such as circuit breakers, transformers, and isolators” [5]. Again, numerous connections and methods are possible for communications, including private, point-to-point connections, such as MIRRORING BITS communications and unidirectional Ethernet. RIO modules based on IEC 61850 communications optionally support Manufacturing Message Specification (MMS) as they publish Boolean equipment signals via GOOSE messaging and subscribe to GOOSE messages to accept control signals to actuate output contacts.
Process interface unit/device (PIU/PID)	“[This unit] combines an MU and a RIO into one device” [5]. PIU/PIDs subscribe to control signals for equipment operation via messages, such as GOOSE messages and MIRRORING BITS communications. They also publish these messages to transmit the equipment status and alarms, and they also publish raw analog values as SV messages or something similar.
Intelligent MU (IMU)	“The IMU ... adds RMS-based [root-mean-square-based] (simple to derive from sampled values) overcurrent and overvoltage backup protection functions in a PIU/PID to prevent damage to the related primary equipment in the event of total communication failure between the IMU and CPC during abnormal system conditions” [5]. An IMU is simply an MU that transmits and receives digital communications and performs logic in the field. For example, a discrete programmable automation controller or a relay can be an IMU.

B. IEC 61869-9:2016 Digital Interface for Instrument Transformers

IEC 61869 is a standard describing general requirements for instrument transformers. Part 6 defines low-power instrument transformers (LPIT), and Part 9 defines LPITs with a digital interface. UCA's "Implementation Guideline for Digital Interface to Instrument Transformers Using IEC 61850-9-2" defined the first methods for interoperable exchange of SV messages and is still in use today [6]. These methods are grandfathered into IEC 61869 Part 9 [7]. IEC 61869 defines conformance classes based on which functions are available within the device, as shown in Table II.

TABLE II
IEC 61869 MU CLASSES

Conformance Class	Definition
Class a	A device with "the minimal set of services required to transmit MU data using sampled values" [7]. This device subscribes to M2M time synchronization messages and publishes M2M SV messages.
Class b	A device with "class a capabilities plus the minimal set of services required to support GOOSE messages" [7]. This device subscribes to M2M time synchronization and GOOSE messages and publishes M2M SV and GOOSE messages.
Class c	A device with "class b capabilities plus the implementation of the IEC 61850 series' information model self-descriptive capabilities" [7]. This device subscribes to M2M time synchronization and GOOSE messages, publishes M2M SV and GOOSE messages, and supports ad hoc H2M queries of the IEC 61850 data model.
Class d	A device with "class c capabilities plus services for file transfer and either one or more of un-buffered reporting and buffered reporting, or logging" [7]. This device subscribes to M2M time synchronization and GOOSE messages, publishes M2M SV and GOOSE messages, and supports ad hoc H2M queries of the IEC 61850 data model and H2M reporting and logging.

C. IEC 62271-3 High-Voltage Switchgear and Controlgear – Part 3: Digital Interfaces Based on IEC 61850

IEC 62271-3 describes digital interfaces based on IEC 61850 for switchgear and control gear and specifies equipment to perform digital communications with other parts of the secondary system. This equipment, which replaces energy signals over field wiring with information within digital messages, can be mounted on the gear internally or externally.

IEC 62271-3 class definitions are shown in Table III.

TABLE III
IEC 62271-3 MU CLASSES

Conformance Class	Definition
Class a	A device with "minimal services to operate switchgear – simple GOOSE only device" [8]. This device subscribes to and publishes M2M GOOSE messages and optionally subscribes to M2M time synchronization messages.
Class b	A device with "services to support IEC 61850 information model (logical nodes) with self-description" [8]. This device subscribes to and publishes M2M GOOSE messages, optionally subscribes to M2M time synchronization messages, and supports ad hoc H2M queries of the IEC 61850 data model.
Class c	A device with "all services applicable for a specific LN [logical node]; configuration, file transfer, logging" [8]. This device subscribes to and publishes M2M GOOSE messages, optionally subscribes to M2M time synchronization messages, and supports ad hoc H2M queries of the IEC 61850 data model and H2M reporting and logging.

III. ANALYSIS OF THREE PREVALENT TOPOLOGIES FOR INTERNATIONAL IN-SERVICE PROCESS BUS APPLICATION SCENARIOS

Separate from the three North American utilities discussed later in the paper, the previous work in [9] summarized observations from utilities in many countries using thousands of IEC 61850 station bus systems. These systems were performing interlocking and substation automation, SCADA, engineering access, and event report retrieval. The most popular topologies were used as the basis to compare and test three process bus scenarios added to relays used in the station bus designs. The three process bus designs were analyzed based on the impact to the substation when connected to a single CPC installed in a station bus network. The CPC station bus implementation remains a constant across all three process bus designs. The comparative analysis includes performance, cost, complexity, resiliency, and security of devices used for the process and station buses based on the IEC 61850 communications standard.

Table IV summarizes the work done by international utilities and compares the three process bus application scenarios.

TABLE IV
PREVIOUS PROCESS BUS SCENARIO COMPARISON

Scenario	Description
A	A CPC relay with IEC 61850 station bus connections also connected across an Ethernet network via an IEC 61850 SV and GOOSE messaging process bus to a field-installed MU (the MU is actually an IMU with logic disabled).
B	A CPC relay with IEC 61850 station bus connections also connected via IEC 61158 process bus direct connections to a field-installed MU.
C	A CPC/IMU relay with IEC 61850 station bus connections installed in the field.

Analysis methods for cost (see Table V) and complexity (see Table VI) are simple aggregations of the components for each scenario and methods first illustrated in [4] and are used to compare the availability of the designs (see Fig. 2).

TABLE V
COMPARATIVE COST ANALYSIS OF INTERNATIONAL SCENARIOS

Item/Solution		Scenario A	Scenario B	Scenario C
Hardware	Protection and control relay	X	X	X
	IMU or MU	X	X	
	Switch	X		
	GPS	X	X	X
	Ethernet fiber interface	X	X	X
Services	Relay panel design	X	X	X
	Project panel MU	X	X	
	Automation panel design	X		
	Fiber launch	X	X	X
	Relay configuration	X	X	X
	MU configuration	X	X	
	Network configuration	X		
Cost Rank*		3	2	1

* Lower is better.

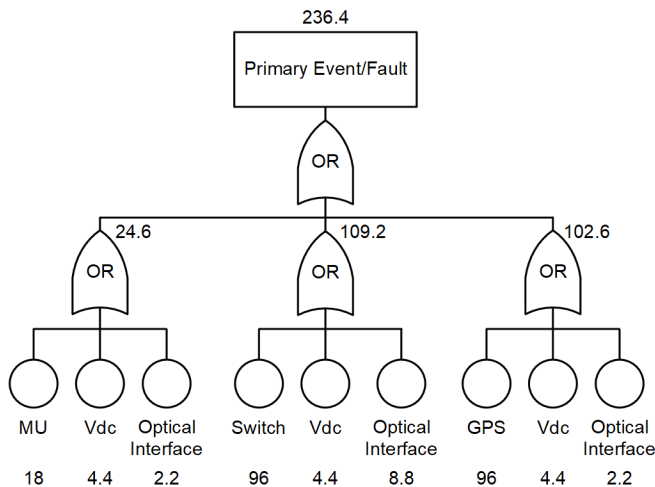

Fig. 2. Comparative Availability Analysis of International Scenarios [4]

TABLE VI
COMPARATIVE COMPLEXITY ANALYSIS OF INTERNATIONAL SCENARIOS

Item	Scenario A	Scenario B	Scenario C	
Tools	Relay software	X	X	X
	MU software	X	X	
	Switch	X		
	GPS software	X	X	X
	Conventional test enclosure	X	X	X
	SV test enclosure	X	X	
	Network analyzer	X		
Knowledge	Protection engineering	X	X	X
	SV network engineering	X		
Complexity Rank*	3	2	1	

* Lower is better.

IV. ANALYSIS OF TOPOLOGIES FOR THREE NORTH AMERICAN UTILITY PROCESS BUS SCENARIOS

As mentioned, this paper introduces topology designs and choices for the process bus communication designs in use at Southern California Edison (SCE) in Rosemead, California, and Commonwealth Edison Company (ComEd) in Chicago, Illinois. It also discusses the research being done at Puget Sound Energy (PSE) in Snoqualmie, Washington. There are many similarities and differences among the designs created by these three utilities and by the international systems mentioned previously.

This section provides valuable insight from the electric utilities willing to share their ideas and observations as an effort to improve the collective experience of the market. Each utility uses modern digital techniques to replace hardwired protective relay trip circuits with digital messaging via IEC 61850 GOOSE, SV, and PTP. Their communication topologies and choices for the process bus communication designs are summarized in the following subsections.

A. ComEd

ComEd provides electric service to more than 4 million customers across Northern Illinois, or 70 percent of the state's population. ComEd is a subsidiary of Exelon Corporation.

1) *Background*

ComEd began using IEC 61850 GOOSE messaging in their first generation of IEC 61850 systems 9 years ago in a distribution station that was part of a distribution automation initiative. The first-generation design included both GOOSE messaging on a station bus and traditional hardwired trip circuits implemented in parallel while the utility gained experience with the new technology. The second-generation IEC 61850 design implemented protection tripping on a station bus using IEC 61850 GOOSE messaging with traditionally wired CT and VT secondary circuits. The third-generation IEC 61850 system, presently in the design phase, will be a full IEC 61850 implementation with a station bus using GOOSE messaging, time synchronization, and H2M communications and a process bus for digitized CT and VT circuits. Lessons learned during the first-generation design influenced the second-generation design station bus and have led ComEd to create a physically separate process bus.

The protocols currently in use on the station bus include IEC 61850 GOOSE messaging, IEEE 1815 (DNP3), PTP, and engineering access protocols. Presently, ComEd is not using IEC 61850 MMS. ComEd staff members have experience with existing DNP3 mapping standards, so those will continue to be used. ComEd will further evaluate the advantages and disadvantages of using MMS to consider if they will use it in the future. One consideration is to move from DNP3 to MMS protocol inside the station bus to supplement the engineering access protocol support of GOOSE and SV event reports in the relays. MMS logical nodes for GOOSE and SV subscriptions (LGOS and LSVS) provide a subset of this information, as described in IEC 61850, and all of the information is available for monitoring GOOSE and SV messages in enhanced implementations of LGOS and LSVS. Valuable statistics that provide information on protection channel performance are calculated and made available within the IEDs that ComEd is implementing. Use of these enhanced logical nodes and other standardized data models may be leveraged by the utility once they migrate from DNP3 to MMS.

One station is currently at the design stage to include SV messaging. To have consistent, repeatable designs as ComEd moves through different generations of IEC 61850 designs, the station bus design will remain the same. ComEd uses the term “process bus” to refer to a network separate from the station bus that will only have SV messages or other digitized CT and VT messages among MUs and subscribing relays. In the initial third-generation installation, the bus differential scheme will be the only protection implemented based on SV messaging and MUs. This will provide ComEd the opportunity to gain the valuable experience needed to understand the new technology. The new system will include a parallel, traditionally wired relay system supporting a supervision or voting scheme for security until ComEd engineers become satisfied with the security of the technology. Table VII further explains ComEd’s operational considerations for the new system.

TABLE VII
COMED’S OPERATIONAL CONSIDERATIONS

Operational Consideration	Description
Cost reduction	Cost reduction is obviously a primary driver. With a rock-solid and repeatable design, the initial investment made in the first few stations will pay off via repetitive, successful implementations in the long run.
Carbon footprint reduction	A reduced carbon footprint is a corporate goal for ComEd. ComEd does not see a strong relationship between these projects and their carbon footprint. Any cost savings from designs, installation, and maintenance will translate to some reduction, but it is difficult to quantify and is not a primary driver for ComEd.
Future nonconventional instrument transformer (NCIT)	ComEd had a previous experience with fiber-optic CTs that was not overly successful. NCITs are not currently part of the roadmap or a consideration for ComEd’s process bus implementation.
Corporate modernization and international standardization	It is important for ComEd to have a modern solution where digital communications are continually monitored. It is not necessarily tied to IEC 61850 alone but is more in line with modernizing substations with various digital communications to minimize maintenance and have more monitoring capability by including a local HMI and enhanced SCADA capabilities. In the future, ComEd will be able to perform tasks, such as completing CT and VT checks and verifying that there are no discrepancies between present relay settings and issued relay settings.

2) *Technology Choices*

ComEd has used IEC 61850 GOOSE messaging since their first-generation designs. They used PTP for time synchronization in second-generation designs and will do the same for their third-generation designs. They are currently studying different process bus technologies, such as time-synchronized, packetized Ethernet IEC 61850-9-2 LE and direct fiber point-to-point time-domain links. DNP3 will remain the station bus SCADA and data concentrator protocol of choice until ComEd further evaluates MMS. The protocol from the station back to the ComEd SCADA system will remain DNP3 for the foreseeable future.

ComEd has been actively considering testing methods during the design phase, and they have purchased modern IEC 61850 test equipment as part of this phase. ComEd has used relay logic to enhance the security of IEC 61850 Mode and Behavior. Changing relay and MU modes (test, block, on, or off) is done locally through the IED front panel. Logic in the IED then prevents the user from resetting the device mode without all the associated conditions first being met. This allows relay logic to be used to condition when the modes are changed. A key goal of the design is to prevent a user from changing IED modes if certain values, such as a protection trip, are asserted. In addition, the relay logic is programmed such that initiating a test trip using local methods can only be done when the IED is in the expected mode. This provides an additional level of security as ComEd field engineers and technicians move from traditional blocking methods to the new testing methods required for the new technology.

ComEd is committed to separating the station and process bus networks. Their designs include redundant networks for the station bus and process bus communications. Station bus networks will be identified as LANs A and B while process bus Parallel Redundancy Protocol (PRP) networks will be labeled LANs C and D. ComEd has selected software-defined networking to provide resilient connections that detect and isolate Ethernet failures and re-establish communications in under 100 microseconds. In addition to this resiliency, ComEd plans to use PRP on LANs A and B. Additionally, ComEd is using best-known methods of unique virtual local-area networks (VLANs) for each GOOSE and SV message.

3) *New Technology in the Workplace*

ComEd plans to train their staff on the new technology. A key initiative of the design is standardization. ComEd has implemented standardization internally through several pre-engineering choices, including consistently using the same GOOSE data sets with the same payload. For example, they have chosen to use the logical node class Generic Process I/O (GGIO) with each indication number representing the same function at every station. Although the logical nodes are labeled GGIO according to the standard, they are not generic in the IEDs ComEd is using, and every data object aligns with a unique internal logic variable in the IED that consistently represents the same function in every IED in every station. This allows ComEd staff to be trained on internal specifications and familiar nomenclature rather than the extended specifications of logical node classes included in IEC 61850.

The focus of ComEd designs is to keep things as simple as possible for training field technicians and new engineers. This method of ComEd terminology embedded within the IEC 61850 data model is a powerful tool for standardization and acceptance of the new technology.

ComEd may decide to use a contractor to assist in training. New training initiatives include a video training series for new staff. This delivery method will be more effective with the third-generation design and will allow staff to access training on demand as needed.

4) *Topology*

ComEd MUs for initial designs will have the ability to provide full line and/or feeder protection in addition to being IEC 61850-9-2 LE publishers. These MUs have station bus and process bus connections. ComEd will use LANs A and B PRP connections to the station bus ports on the MUs. The MUs will use fast failover between redundant process bus ports and software-defined networking within the process bus. In the future, ComEd will consider adding PRP to the process bus LANs. They are considering additional process bus technologies, such as including up to four direct fiber time-domain connections, rather than switched packets, from each MU to multiple subscribers.

The MUs selected by ComEd support GOOSE messaging on the station bus and process bus connections to the device. However, ComEd will implement digital tripping communications via GOOSE messaging on the station bus, rather than the process bus, to allow for repeated designs in

stations with and without a process bus. Some technologies, such as a direct fiber point-to-point process bus, will require support station bus and direct link trip commands.

5) *Metrics*

ComEd is primarily focused on design standardization across all voltage levels as a key metric of their substation enhancement program. Standardizing on hardware is a key component of this approach. ComEd's goal is to have the same look and feel for all new IEC 61850 substations. In some instances, ComEd plans to use only a subset of features available in an IED, which, although not an added cost, does not maximize the value-added metric. They believe that the standardized approach to hardware will provide savings due to the standard designs, similarity in station and process bus deployment, and familiarity of the equipment during testing and maintenance operations. Reduced engineering costs is also a key metric for ComEd. It may be several years before this metric can truly be analyzed because the designs move through generations and are adjusted from lessons learned.

As with any new technology or staff, additional training will be required as field technicians and design engineers are introduced to the IEC 61850 stations. A key identifier of the success of the program will be how the design engineers and field technicians react to working on these new systems. The goal is to have them prefer to work on these systems rather than traditional systems that use hardwired circuits. When this happens, the program will be considered a success.

The IEC 61850 upgrade program represents a significant change in deployed technology at ComEd. This modernization in the long run will allow ComEd to move out maintenance activities to the longest allowable interval indicated in the North American Electric Reliability Corporation (NERC) requirements.

Monitoring digital protection channels is another key metric to moving maintenance activities to the longest possible intervals. This includes all of the information in the extended LGOS and LSVS.

6) *Lessons Learned*

The second-generation designs include PTP for time synchronization. Time synchronization that is capable of high accuracy will be critical for an SV-based implementation in the third-generation design. During second-generation design testing, ComEd expects that all PTP and network-related issues will be resolved. This will simplify the process bus implementation in the third-generation design because ComEd will already have a proven PTP design that has been verified with in-service experience.

ComEd's major concerns with security are tied with operational issues, including locking down firmware and updating designs moving forward. Implementing software-defined networking for both process and station buses provides defense-in-depth and deny-by-default security that prevents any unauthorized or nonengineered traffic. Any unauthorized traffic can be routed to an intrusion detection appliance for analysis.

B. SCE

SCE is the largest subsidiary of Edison International and provides electricity across Southern California. They provide electric power to approximately 15 million residents across a service territory of approximately 50,000 square miles.

1) Background

In 1994, SCE introduced networked communications with Modbus Plus protocol. In 2004, SCE introduced the first generation of modern Transmission Control Protocol/Internet Protocol (TCP/IP) networking in the substation with use of Modbus TCP/IP. In 2014, SCE standardized on IEC 61850 MMS communications within distribution substations, and they are currently working on standardizing MMS at transmission substations.

In 2016, SCE started investigating and evaluating process bus products in a laboratory to determine the feasibility of process bus technology in their system. In 2017, SCE started a process bus demonstration project along with an evaluation of optical CTs. The scope was limited to a single subtransmission line with an optical CT and conventional MUs. SCE left the traditional distance protection in place in order to compare the performance of the traditional designs with the new process bus network. This system has been in service since June 2019 and has performed as expected thus far.

A field demonstration served as the next step into SCE’s process bus exploration. The equipment for the demonstration project was installed in an existing station, not a greenfield station. SCE was looking to gain experience designing and testing a process bus field installation. Table VIII further explains SCE’s operational considerations for the new system.

TABLE VIII
SCE’S OPERATIONAL CONSIDERATIONS

Operational Consideration	Description
Cost reduction	If standardized, the process bus system replaces hundreds of copper cables with fiber-optic cables, may shrink the necessary footprint of the control house by 30 to 50 percent, saves panel space with digital controls, and enables easier and simpler installation.
Carbon footprint reduction	California has made a major effort to combat climate change, and SCE will be a key player in this effort. Although this demonstration system did not specifically address reducing their carbon footprint, future phases will include a more thorough analysis and evaluation.
Future NCIT	The evaluated unit operated as expected. If there is a need for this technology in the future, SCE can use what was learned in the demonstration. Potential benefits are reducing electrical hazards; eliminating CT saturation; offering a lightweight solution; and supporting protection, metering accuracy class, and IEC 61850 SV messaging.
Corporate modernization and international standardization	SCE is moving toward open standard technologies, such as IEC 61850, for substation modernization.

2) Technology Choices

SCE used MMS on the station bus and PTP, SV, and GOOSE messaging on the process bus during the demonstration.

SCE tested various methods in the laboratory and field. In the laboratory, a system representative of the field installation was constructed in order to provide the best testing environment possible. SCE used traditional test sets to connect to MUs and simulate secondary voltage and current, which would normally have conventional current inputs hardwired from the field. A real-time digital simulator (RTDS) was also used to run through hundreds of automated tests to ensure that the system behaved as expected, which provided additional confidence. Test sets also provided the capability to mimic MUs, thereby allowing relay protection functions to be tested in the network instead of using traditional protection test plugs for analog injection. This method was tested in the laboratory and provided good results.

However, during the system commissioning, SCE decided to include the MUs and not simulate them. This method of testing was necessary to accurately represent the system end-to-end. For testing the optical CT, copper wiring was wound around the CT in order to simulate primary current. Therefore, 1 ampere would simulate 30 amperes of primary current. This was also included in the field installation of the optical CT and terminated at a terminal block in the circuit breaker cabinet for easy access. The test plans for the system had to be slightly modified from the standardized plans in order to properly test the protection. IEC 61850 Edition 2 test modes were not available in the units at the time and will be evaluated in future projects.

For the demonstration, separate process and station buses were designed in order to isolate the SCADA traffic from the process bus traffic. PTP, SV, and GOOSE messages were restricted to the process bus network, and the monitoring system was used to compare traditional analog data with process bus data. Periodic and event-triggered Common Format for Transient Data Exchange (COMTRADE) captures were obtained for analysis. An MMS/Modbus TCP converter was required in order for reclosing automation to work with the substation programmable logic controller. The traditional MU, which was primarily used for voltage sensing, also served as a secondary current source for the protective relay. If the relay detected an issue with the optical CT, it would swap over to the current stream from the traditional MU (see Fig. 3).

SCE chose not to create unique message VLANs for this single breaker bay. SCE will be establishing more comprehensive traffic management in future projects.

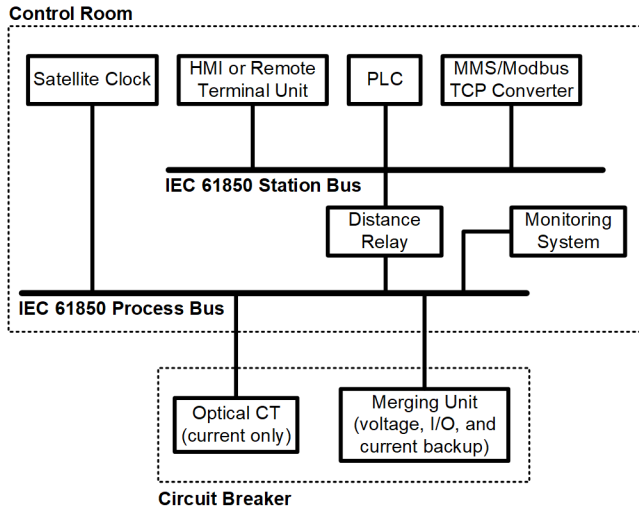

Fig. 3. Topology Diagram for the Demonstration

3) *New Technology in the Workplace*

Training was limited to the personnel directly involved with the demonstration, and there was no need to hire additional resources. Documentation, maintenance, and operational training procedures were created to support the field personnel. Two manufacturers provided onsite training during testing and installation.

4) *Topology*

A traditional MU in the circuit breaker provided the relay with circuit breaker status and control information. A monitor mode was implemented in the relay to provide additional confidence and to analyze the relay behavior for a month after being put into service. The monitor mode allowed the relay to sense faults and pickup protection elements but not trip the breaker. This was acceptable, since traditional protection was in parallel.

5) *Metrics*

For the demonstration, the overall hardware costs were double the traditional design. These include one-time costs, such as seismic testing and a modified circuit breaker design to accommodate the process bus equipment. However, some of these costs are expected to be either reduced or eliminated once the hardware is standardized. The optical CT was significantly more expensive than a traditional CT; however, it may provide a better cost benefit ratio in high-voltage applications (220 kV or greater).

Similar to the hardware costs, initial engineering and design costs were double the traditional costs. However, these costs are expected to be reduced as the elementary and wiring diagrams are standardized.

For the limited scope, relay test plans were designed similar to traditional testing with the addition of process bus communications testing. This simplified field training.

Traditional methods of analyzing COMTRADE files created by relays were used. Additional analog, network, and SV analyzers were also used in order to evaluate performance. Periodic and event-triggered captures of the system allowed for steady-state and fault analyses between the traditional and process bus systems.

6) *Lessons Learned*

Time synchronization plays a critical role in process bus systems. Yet there may be methods to minimize the reliance on the Global Positioning System (GPS) clock, such as using a single MU for applications that require voltage and current. Redundant clocks should be considered if there is protection dependency on time synchronization. For the demonstration, the traditional MU also had conventional current inputs and served as a fallback current source if an issue arose with NCIT or time synchronization was lost.

Thorough cybersecurity and NERC CIP compliance design considerations should be made when designing the process bus system.

If possible, it is recommended to use an analyzer that can subscribe to SV messages and also have inputs to analog current and voltage channels to analyze performance comparisons.

Manufacturers should have a clear definition of the sensor head-to-bushing number. They should also have all process bus equipment going in the circuit breaker when they manufacture it to make sure that all equipment fits properly.

It was observed that many basic features and functionalities were lacking from manufacturer products in the area of IEC 61850 file management, such as exporting or importing Substation Configuration Language files and supporting the MMS server. Therefore, optical CT technology users should carefully evaluate the IEC 61850 functionality prior to manufacturer selection.

Locking down specific firmware is critical to commissioning the system because there may be inadvertent failures in the field regarding the unit showing up with new firmware. What was tested in the laboratory should be what is installed in the field, unless there is a valid reason to upgrade and it has been tested in the laboratory.

It quickly became apparent that connectivity to the field devices in circuit breakers became valuable for test set and MU access. Careful cybersecurity and NERC CIP compliance design considerations should be made when designing device access.

Power system simulator test set connections should be designed into the system. The design should include test set access to outside devices from the control room. For the demonstration, existing test power connections were made to achieve this.

Optical CTs require primary or simulated primary currents to perform testing. SCE requested for the manufacturer to implement 30 turns around the optical CTs to simulate primary currents using conventional power system test sets.

For complete process bus substations, circuit breaker redesign or modification should be considered to accommodate built-in MUs.

C. *PSE*

PSE serves approximately 1.1 million electric and 840,000 natural gas customers within a service area of 6,000 square miles, primarily in the Puget Sound region of Western Washington.

1) *Background*

PSE has been installing Ethernet networks into substations since 2012. Currently, highly reliable, high-speed Ethernet networks are in all transmission substations and approximately half of the distribution substations.

The currently installed substation Ethernet networks are considered station bus systems. They are responsible for passing DNP3/IP SCADA data and remote user access traffic. However, there are two substations that do pass some GOOSE messages between local relays in a noncritical application.

In 2017, PSE began exploring the potential of using IEC 61850-based GOOSE and SV messaging for protection and control in a substation. To date, a process bus has been implemented in a laboratory. PSE is in the process of designing its first substation that will use IEC 61850 GOOSE and SV messaging with a separate station bus and process bus architecture. Table IX further explains PSE’s operational considerations for the new system.

TABLE IX
PSE’S OPERATIONAL CONSIDERATIONS

Operational Consideration	Description
Cost reduction	Before the research started, PSE compared the cost of labor and materials between a traditional substation and a new IEC 61850-based substation. The study was based on a traditional transmission substation that was built in 2018–2019 time frame. Approximately 40,000 feet of copper cabling was used in that project. The substation control house had a large footprint because of the number of racks and the size of the cableway. In the analysis, a new IEC 61850 substation would use approximately twice the number of microprocessor-based pieces of equipment. This included additional dual MUs for each field apparatus, additional switches for the process bus, and the same number of protective relays. The amount of control house space and field cableway size and the number of racks, separate lockout relays, and standard control switches were reduced. To keep an equivalent comparison between the traditional substation and the new IEC 61850 substation, PSE did not include the labor cost for adding features and functions that were not available in the traditional substation. For this particular substation comparison, there would be a total cost reduction of approximately \$300,000.
Carbon footprint reduction	PSE estimated that their new design reduced their transmission substation carbon footprint by an average of 90 percent. This preliminary calculation simply looked at the difference in energy needed to manufacture copper wire versus fiber-optic equipment. PSE anticipates this will further be affected by the amount of fuel needed to transport materials or manufacture a smaller control house and other items that are associated with reduced weight and physical size.
Future NCIT	PSE did not significantly consider the impact on future use of NCITs. This is perceived as a nice addition for the future but is a step too far for their first IEC 61850 substation.
Corporate modernization and international standardization	PSE’s directive is to move into the forefront of new technology. Being in the Seattle area, many of their customers are very technology-forward. They routinely ask PSE about their position on grid modernization.

2) *Technology Choices*

Throughout the years, proprietary protocols have come and gone. PSE, and probably many other utilities, still have to support some legacy SCADA protocols. These protocols were the first of many serial-based protocols in which special hardware was required. The mindset of the utilities is that the equipment should have a lifetime of at least 10 years. However, it is unlikely that utilities truly follow a 10-year replacement cycle of their microprocessor-based equipment in a substation. Also, substations are routinely expanded and not very often completely replaced. Therefore, when considering protocols and their compatibilities, the designer strives to build a substation control system that will perform its core function and allow microprocessor-based equipment to come and go over the course of 15 or even 20 years.

In recent years, PSE has installed bulk battery storage systems. These systems have equipment that needs to communicate with traditional substation devices. It seems that the future requires more standardized communication compatibility rather than more proprietary protocols. PSE has had many internal discussions about the direction of the substation control systems. Anything proprietary is hard to justify when taking a holistic, long-term viewpoint. Therefore, at this time, PSE is only considering using standardized protocols that are open to all manufacturers.

PSE is currently completing laboratory testing and has started at the basics. Equipment is connected to mimic the proposed substation control system architecture. The device sequence of events recordings are monitored to determine if it is performing correctly. So, switches and cables are unplugged or powered down to simulate a cable or device failing in the substation. The device sequence of events logs are then analyzed to determine if protection or control was lost to either or both of the dual-primary systems. At this time, to match their legacy system, PSE designs for complete redundancy. Protection speed testing has been completed through black-box testing compared to PSE’s standard relaying. The laboratory has the standard protective relays and the new IEC 61850-based relaying system. PSE injected the same fault into both systems at the same time and compared the timing of the trip output contacts. These tests are run repeatedly to ensure that there are no outliers and to determine the average speed penalty when using the new system.

PSE is designing a system that uses a separate station bus and process bus. Their architecture has a Station Bus A and Process Bus A system and a Station Bus B and Process Bus B system. The dual-primary protection and control system also follows this A and B system. The entire A system can be taken offline without a loss in functionality at any time. Although this seems simple, it can be challenging to accomplish.

Currently, PSE is still researching the best communication architecture. They are evaluating standard, managed switches and software-defined networking switches. As with everything, there are both pros and cons to each type of switch and architecture. Also, PSE is evaluating PRP and High Seamless Redundancy (HSR) networks as well as a hybrid of these. The exact architecture is determined in some respects by the

capability of all the connected devices. The evaluation is still proceeding at this time.

3) *New Technology in the Workplace*

PSE is extremely fortunate that their operations staff members are very competent, forward-thinking, and supportive about digital substation implementation. PSE has had many discussions regarding the workflow processes associated with the change in substation design. The modification of the workflow process can be very challenging and will consume a lot of time.

The initial internal training for groups that are impacted by the new technology has been very important. This training provided a critical feedback channel from the many engineering and operations groups. As a result, PSE has taken a step back and started to clearly define the roles and responsibilities of each group in the development and implementation of this technology. It is recognized that the relay technicians, wiremen, and communications technicians will have to significantly change their work practices. The relay technicians will become Ethernet-savvy, and the wiremen will complete fiber-optic terminations. All this has been perceived as a positive change because they want to learn new skills that keep them relevant in the future.

PSE has not hired new engineering staff to implement digital substation technology, but they fortunately do have some staff members who have been hired in the last 5 years who have experience with this type of implementation. Also, PSE continues to work with manufacturers to learn and implement the technology. PSE does recognize the need to implement significant internal and external training for the relay technicians because they are the primary troubleshooters at PSE.

4) *Topology*

Successful implementation of the technology at this time requires some flexibility. This became evident when taking into account the functionality of all the devices that are required in a substation control system. There are optimal balance points, much like protective relaying systems, that balance speed, selectivity, and security. The digital substation topology does require some give and take. PSE first chose the devices that were revisions of their current devices. They tried not to introduce all new device manufacturers for the specific functions.

The core function of the devices and why they used them in the past held significant importance. Sometimes, this required that the topology be modified in order for the device implementation to work. Mechanical packaging, user interface, software, speed, reliability, cost, and more were all considered when selecting devices. At this time, the MU and IMU are connected to redundant process bus switches and to the station bus. However, there may be a limited amount of traffic that will traverse the process bus to get to the station bus because of device limitations. Allowing this flexibility in some cases allows the flexibility to use preferred relay and MU devices.

PSE will use a digital trip signal. The relays produce the trip signal and issue a proper GOOSE message. The MU subscribes to the appropriate GOOSE bit and will trip or close the breaker appropriately. This architecture lends itself to using virtual lockout relays. The lockout functionality will be in the relays, and the reset is initiated by using relay pushbuttons.

5) *Metrics*

PSE estimates the smart device hardware cost will be increased by 80 percent, and the control house, racks, cabling, terminations, and cable trench will be decreased by an aggregate of 40 percent.

PSE estimates that the engineering cost after the first project will decrease by 20 percent for greenfield designs and will be the same cost for brownfield, hybrid systems as compared to the traditional architecture.

PSE has analyzed the pros and cons associated with the need for knowledge. Although the digital substation project will take the brunt of the cost associated with training, many other areas will benefit. For example, PSE is installing bulk battery storage systems and a new advanced distribution management system. Both of these programs will benefit greatly from the Ethernet network training and troubleshooting of bits, bytes, software code, logic, and all of the smart device capabilities. This growth area is seen as benefiting all of their grid modernization efforts. It can help them build a smart-grid-ready workforce.

It is expected that the first installation will take 30 percent more time testing because of the learning curve, and many hours will be spent developing test plans. However, PSE believes that these costs will eventually be the same or less when compared to testing the traditional substation protection and control system.

When researching the IEC 61850 digital substation system, PSE used Wireshark and the sequence of events logs in the smart devices. Much more needs to be done in this area during the next phase of project development. PSE plans on working with the manufacturer of their relay test set to develop methods for testing at the bit level in the future. For the current project, it will be tested similarly to a traditional substation by injecting current and voltage into the system and noting the timing of the trip contact outputs and reviewing the sequence of events logs.

6) *Lessons Learned*

During the initial research, PSE did observe the critical nature of time synchronization. Virtually all of the protection will cease to work if the GPS or Global Navigation Satellite System (GNSS) time system is down. The PSE architecture employs three or more IEEE 1588 clocks that maintain the proper clock signal to support protection. Although this is acceptable for the pilot project, PSE plans on investigating this further for more solutions.

Although it is out of the scope of this paper, PSE's position on cybersecurity is the same as for traditional substations that use Ethernet for both SCADA and remote access.

V. CONCLUSION

The summary of international station bus installations and process bus investigations provides a great backdrop for the discussion of digital secondary systems. Ideas, observations, lessons learned, and topology design choices for recent process bus IMU and digital trip circuit implementations, shared directly by the engineers at three North American utilities, provide valuable insight to the collective experience of the industry.

Cost reduction is an important driver for adopting a process bus system. The utilities expect that with a rock-solid and repeatable design, the initial investment will pay off with repetitive, successful implementations in the long run. Some areas where expressive cost reductions are forecasted include copper control cables, equipment racks, control house space, control cable trenches, and conventional lockout relay and control switch elimination.

However, each utility points out that it is critical to design a protection system that is economically feasible for the initial and future implementations. The designs must also meet the appropriate performance requirements for protection (i.e., speed, security, reliability, selectivity, and sensitivity) for the criticality and characteristics of each application.

The authors predict that the future utility implementations will rely on standardized station bus and process bus communications compatibilities. One utility is considering also adding proprietary process bus connections for simplicity and security and another is installing an NCIT.

The authors preferred using IMUs as described in the technical report “Centralized Substation Protection and Control” [5], rather than MUs. This is because IMUs can provide local protection to prevent damage to the related primary equipment in the event of a total communications failure between the publisher and subscriber in a process bus installation. The selected IMUs can be connected to the station bus and process bus simultaneously. However, each utility expressed a preference for an engineering design that uses separate station and process buses.

The utilities favor using digital trip signals, since they gained experience and confidence using them during previous station bus projects. Each of these utilities, like most around the world, chose to apply GOOSE messaging on the IMU station bus connections for digital tripping. This permits a standardized digital trip circuit standard design to be applied in stations with and without process buses.

It is unanimous among all three utilities that time synchronization plays a critical role in process bus systems that apply IEC 61850 SV protocol when IEDs subscribe to SV streams from multiple MUs. PTP is the preferred method for time synchronization within the substation, and redundant clocks are considered necessary because digital process bus protection depends on time synchronization. One utility is also implementing a direct fiber point-to-point process bus with trip commands over a dedicated fiber-optic link to minimize the reliance on the GPS clock.

Careful cybersecurity and NERC CIP compliance design considerations should be made when designing process bus systems and device remote access. SDN is considered a technology that creates a more cybersecure network while also providing the fastest healing time for the network.

Presently, only SCE is considering using NCITs. PSE and ComEd perceive this as a possible enhancement to the system in the future but is out of the scope for their initial process bus implementations.

Modifying the workflow process imposed by implementing digital trip circuits and process buses is very challenging and requires a considerable amount of time. The initial training for groups that are impacted by the new technology is very important as is the step to clearly define the role and responsibilities of each group in the development and implementation of the new technology.

It is recognized that relay and communications technicians will face a significant change in their work processes. For instance, relay technicians will need to learn more about Ethernet networks. This is not perceived as a negative effect of the new technology but as a positive change that will allow them to learn new skills that keep them relevant in the future.

VI. ACKNOWLEDGMENTS

Though MMS and GOOSE installations date back to 2001, Comisión Federal de Electricidad (CFE, the state-owned electric utility of Mexico) designed and installed the world’s first successful IEC 61850 station bus system in the La Venta II substation in 2006. This substation performed digital tripping via GOOSE messaging on the station bus as well as SCADA and engineering access. Lessons learned from this important digital secondary system milestone benefit the industry greatly, and we owe CFE a debt of gratitude for sharing their experience publicly. Similarly, the industry will learn more about process bus installations because of this paper. The authors gratefully acknowledge the contributions of ComEd, SCE, and PSE because this paper could not have happened without them sharing their experiences.

VII. REFERENCES

- [1] D. Dolezilek, D. Gammel, and W. Fernandes, "Complete IEC 61850 Protection and Control System Cybersecurity Is So Much More Than Device Features Based on IEC 62351 and IEC 62443," proceedings of the 10th Annual Protection, Automation and Control World Conference, Glasgow, UK, June 2019.
- [2] D. Dolezilek, P. Lima, G. Rocha, A. Rufino, and W. Fernandes, "Comparing the Cost, Complexity, and Performance of Several In-Service Process Bus Merging Unit Solutions Based on IEC 61850," proceedings of the 15th International Conference on Developments in Power System Protection, Liverpool, UK, March 2020.
- [3] D. J. Dolezilek and A. Kalra, "Comparison of Standardized Protocols Available to Replace Substation Copper Field Wiring With Digital Communications," proceedings of the 14th International Conference on Developments in Power System Protection, Belfast, UK, March 2018.
- [4] G. W. Scheer and R. E. Moxley, "Digital Communications Improve Contact I/O Reliability," proceedings of the 7th Annual Western Power Delivery Automation Conference, Spokane, WA, May 2005.
- [5] Working Group K15, "Centralized Substation Protection and Control," IEEE PES Power System Relaying Committee Report of Working Group K15 of the Substation Protection Subcommittee, December 2015. Available: pes-psrc.org/kb/published/reports/IEEE_PES_PSRC_WG%20K15_Report_CPC_Dec_2015.pdf.
- [6] UCA International Users Group, "Implementation Guideline for Digital Interface to Instrument Transformers Using IEC 61850-9-2," July 2004. Available: iec61850.ucaiug.org/Implementation%20Guidelines/DigIF_spec_9-2LE_R2-1_040707-CB.pdf.
- [7] IEC 61869-9, Instrument Transformers – Part 9: Digital Interface for Instrument Transformers, 2016.
- [8] IEC 62271-3, High-Voltage Switchgear and Controlgear – Part 3: Digital Interfaces Based on IEC 61850, 2015.
- [9] D. Dolezilek, P. Lima, G. Rocha, A. Rufino, and W. Fernandes, "Cost and Performance Comparison of Numerous In-Service Process Bus Merging Unit Solutions Based on IEC 61850," proceedings of the 10th Annual Protection, Automation and Control World Conference, Glasgow, UK, June 2019.

VIII. BIOGRAPHIES

John Bettler has a BSEE from Iowa State and an MSEE from Illinois Institute of Technology. John has worked at Commonwealth Edison Company (ComEd), a power company in the Chicago area, for 29 years. He has experience as a field engineer and protection engineer. Currently, he is the principal engineer for ComEd's relay section. His team's purview includes 4 kV and 12 kV feeders up to 765 kV transmission lines and all transmission and distribution equipment in between (e.g., TR, buses, cap, and inductors). John's team also reviews interconnections, independent power producers, and distribution generation projects. John is also adjunct faculty at IIT and UW Madison teaching power and protection classes. He is a PE in Illinois.

Jesse Silva received his Bachelor of Science in electrical engineering from the University of California, Irvine. He is a senior engineer at Southern California Edison (SCE). In 2006, Jesse joined SCE in the substation automation department as an automation engineer where he supported the commissioning of substation automation systems across the SCE territory. He currently works in the T&D Innovation organization where he evaluates and demonstrates new substation automation technologies for SCE.

Dan Morman received his Bachelor of Science in electrical engineering from North Dakota State University in 1992. Dan has been involved in the electric power industry for 28 years. Dan has a wide background, having spent 13 years at different utilities in substation engineering roles, 9 years as a design consultant for power plants and substations, 4 years as a field integration and support engineer, and 2 years in product development. He has worked for Black & Veatch, Central Power Electric Cooperative, Inc., Arizona Public Service, and Schweitzer Engineering Laboratories, Inc. Currently, he is a consulting engineer at Puget Sound Energy in the protection, automation, and controls group. His career focus is centered on substation integration and automation as well as many elements of grid modernization. Dan is a registered professional engineer and a member of IEEE.

Ricardo Abboud received his BSEE degree in electrical engineering from Universidade Federal de Uberlândia, Brazil, in 1992. In 1993, he joined CPFL Energia as a protection engineer. In 2000, he joined Schweitzer Engineering Laboratories, Inc. (SEL) as a field application engineer in Brazil, assisting customers in substation protection and automation. In 2005, he became the field engineering manager, and in 2014, he became the engineering services manager. In 2016, he transferred to Pullman, Washington, and is currently an international technical manager. He is a certified instructor at SEL University, and has authored and coauthored several technical papers.

David Bowen, CTech, is a graduate of the EET program at Georgian College in Barrie, Ontario, Canada. He is currently an application technologist for automation products in the sales and customer service division at Schweitzer Engineering Laboratories, Inc. (SEL). David has held this position with SEL since 2008. In this role, he provides training and assistance to customers applying SEL power system protection, automation, and communication products. Before coming to SEL, he spent 17 years working in protection, control, and automation departments at utilities in the greater Toronto area. During this time, he performed system integration for protective relays in applications ranging from 230 kV utility substations to low-voltage distribution and from electromechanical relays to modern digital relays. David specializes in power system automation, legacy system integration protocols, and modern IEC 61850-based systems.

Ed Cenzone is an engineering manager at Schweitzer Engineering Laboratories, Inc. (SEL). Ed joined SEL in 2005 as an integration/automation engineer. He contributes to the development, maintenance, and support of communications protocols and functionality in SEL's transmission and substation lines of protective relays. Prior to SEL, Ed worked at ABB Systems Control in Santa Clara, California, where he concluded his 5 years of service as a senior systems engineer. Prior to that, he was at the Guam Power Authority, completing 11 years of service as a system planning engineer, maintaining the SCADA system he helped install. He is a registered professional engineer (Guam) and is a member and officer of various working groups in the IEEE PSCCC and PSRC. He received his Bachelor of Science in Electrical Engineering from Marquette University in Milwaukee, Wisconsin in 1990.

David Dolezilek is a principal engineer at Schweitzer Engineering Laboratories, Inc. and has three decades of experience in electric power protection, automation, communication, and control. He develops and implements innovative solutions to intricate power system challenges and teaches numerous topics as adjunct faculty. David is a patented inventor, has authored dozens of technical papers, and continues to research first principles of mission-critical technologies. Through his work, he has created methods to specify, design, and measure service level specifications for digital communication of signals, including class, source, destination, bandwidth, speed, latency, jitter, and acceptable loss. As a result, he helped coin the term operational technology to explain the difference in performance and security requirements of Ethernet for mission-critical applications versus IT applications. David is a founding member of the DNP3 Technical Committee (IEEE 1815), a founding member of UCA2, and a founding member of both IEC 61850 Technical Committee 57 and IEC 62351 for security. He is a member of the IEEE, the IEEE Reliability Society, and several CIGRE working groups.