

Redundant Bus Protection Using High-Impedance Differential Relays

Josh LaBlanc

Schweitzer Engineering Laboratories, Inc. (formerly of Minnesota Power)

Michael J. Thompson

Schweitzer Engineering Laboratories, Inc.

Presented at the

47th Annual Western Protective Relay Conference

Virtual Format

October 20–22, 2020

Previously presented at the

71st Annual Conference for Protective Relay Engineers, March 2018

Originally presented at the

53rd Annual Minnesota Power Systems Conference, November 2017

Redundant Bus Protection Using High-Impedance Differential Relays

Josh LaBlanc, *Schweitzer Engineering Laboratories, Inc. (formerly of Minnesota Power)*
 Michael J. Thompson, *Schweitzer Engineering Laboratories, Inc.*

Abstract—Minnesota Power is assessing ways to improve redundancy of protection systems for compliance with North American Electric Reliability Corporation (NERC) Standard TPL-002 — System Performance Following Loss of a Single BES Element. Historically, buses rarely included dual differential systems and relied on time-delayed remote backup to cover a failure of the bus protection system. Today’s highly stressed power system is less tolerant of delayed fault clearing with loss of multiple branch circuits for a single-contingency failure. Therefore, determining ways to achieve dual high-speed protection systems for buses has become important. Historically, Minnesota Power has used high-impedance bus differential (87Z) protection systems. This principle has many advantages, including high performance, virtually no limit to the number of branch circuits, simple current transformer (CT) wiring, and simple settings calculations. This paper examines various options for obtaining redundancy. The paper includes an emphasis on examining various methods of applying dual 87Z relays in an existing bus differential CT circuit.

I. INTRODUCTION

Minnesota Power is assessing ways to improve redundancy of protection systems as part of compliance with North American Electric Reliability Corporation (NERC) Standard TPL-002 — System Performance Following Loss of a Single BES Element. We have reviewed our protection schemes at substations that contribute the most to bulk electric system (BES) stability and security. From this review, we identified several system protection single points of failure resulting in greatly extended tripping zones or fault clearing times. As a result of this review, we are taking steps at one of our most important substations, shown in Fig. 1, to greatly reduce the risk of a single point of failure having a detrimental effect on the reliability and security of the transmission system.

Minnesota Power identified two single points of failure that resulted in an extended clearing zone at this critical site. The first single point of failure was the use of a single tie breaker at the site. The impact of this failure was mitigated with the installation of dual tie breakers in series, both equipped with breaker failure schemes and an additional tie bus relaying scheme. This improvement is not in the scope of this paper and is not discussed further.

The second identified single point of failure, and the focus of this paper, was the use of a single bus electromechanical relaying protection scheme. These relays did not provide redundancy for single-line-to-ground faults, which resulted in

an extremely extended tripping zone. Different options for achieving redundancy to mitigate the impact of this failure are studied and discussed within this paper.

II. BACKGROUND

The substation in the Minnesota Power case study has a 115 kV straight bus arrangement with two bus sections, which are now separated by tandem bus-tie breakers, as shown in Fig. 1. Comments regarding the applicability of various solutions to other bus arrangements, such as breaker-and-a-half, are included in this paper for completeness of discussion.

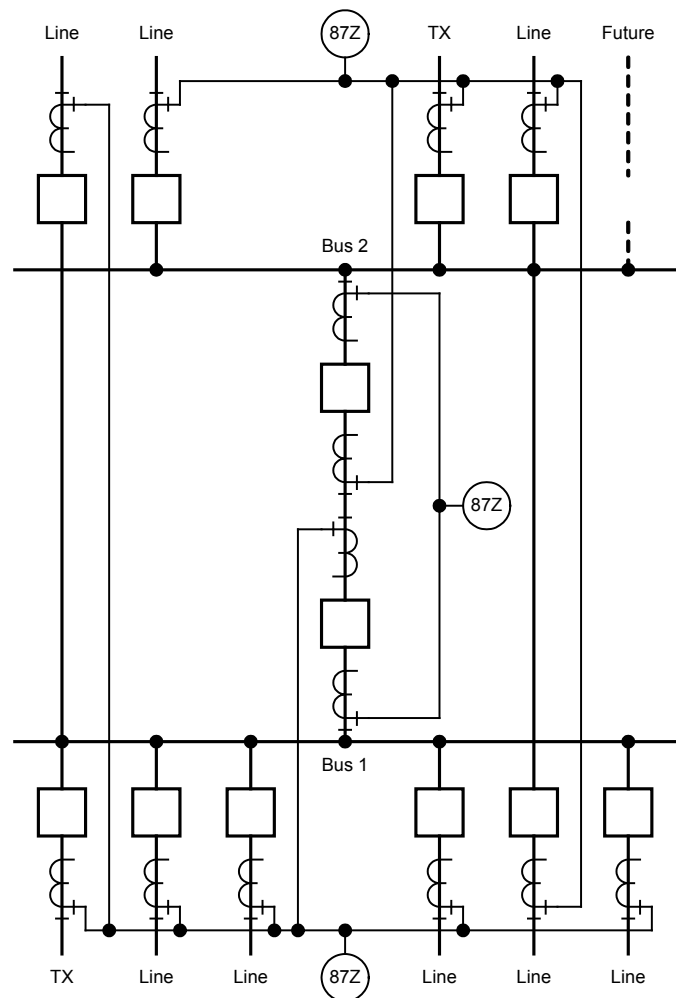

Fig. 1. Substation single-line diagram

Redundant bus protection systems were uncommon in the past for the following reasons:

- Bus protection systems require high selectivity to provide clearing with no intentional time delay. For this reason, differential relaying is the preferred principle. Traditionally, differential relaying required a dedicated current transformer (CT) circuit and CTs were not often available for two differential relaying protection systems.
- Remote backup using the branch circuit time-delayed overreaching elements is dependable. A fault on the bus section is electrically indistinguishable from an in-zone, end-of-line fault for the remote relays. Thus, failure of a nonredundant bus protection system did not result in a failure to trip—it only resulted in delayed tripping and loss of the various branch circuits connected to the bus.

Today's highly stressed power system is less tolerant of delayed fault clearing with loss of multiple branch circuits for a single-contingency failure. Therefore, determining ways to achieve dual high-speed protection systems for buses has become important.

Minnesota Power prefers high-impedance bus differential (87Z) protection systems. This principle has many advantages, including:

- High performance, including high speed, high sensitivity, and high security.
- Virtually no limit on the number of branch circuits connected to the bus.
- Simple CT wiring with CTs wired to a summing junction located in the yard and a single set of leads brought into the control building.
- Extremely simple settings calculations.

While the focus of this paper is examining the feasibility of applying dual high-impedance (87Z) relays in the existing high-impedance bus differential CT circuit, other means of obtaining redundancy are also discussed.

III. METHODS TO OBTAIN REDUNDANT BUS PROTECTION

In general, it is better if the redundant bus protection system is independent of the primary bus protection system to eliminate the possibility of common mode failures.

Redundant relays that share the same CT circuit do not provide complete independence. However, this approach significantly improves the situation over relying strictly on remote backup. If the system is designed with proper means for isolation, installing redundant relays in the same CT circuit supports periodic testing and maintenance by allowing a protective relay to be isolated and taken out of service without disabling selective high-speed relaying. This scheme also provides dependability for failure of one of the relays until repairs can be made. Considering that the CTs and associated wiring are extremely reliable and not prone to failure, this approach covers the components of the circuit that are most likely to fail or require periodic maintenance.

This section discusses alternatives to achieve the desired redundancy. To introduce the discussion, it is first necessary to consider the options available. The following summarizes Table 1 of IEEE Standard C37.234-2009, IEEE Guide for Protective Relay Applications to Power System Buses [1]. The five protection systems considered are:

1. Differentially connected overcurrent scheme.
2. Percentage restrained (standard and advanced) differential scheme.
3. High-impedance differential (87Z) scheme.
4. Zone-interlocked directional blocking scheme.
5. Time-coordinated relays that overlap the bus zone scheme.

A. Constraints to Consider in Evaluating Options

There are, of course, many constraints governing which options are viable for any given application. The following three subsections briefly discuss some of these constraints. A utility may consider some of these options as alternatives to applying dual 87Z protection, depending upon the circumstances.

1) Availability of Panel Space

Some options discussed require additional relays. To add separate bus protection systems such as a multirestraint, low-impedance bus differential relay, space for the new relays and their associated test switches must be available either in the existing panel or in a new panel in the substation control building. In the case study substation, an additional panel would be required because the buses share the same panel and there is not room for both high-impedance and low-impedance options for each bus on one panel. Furthermore, the substation control house lacks the space to add another panel.

2) Outage Requirements to Install and Test Each Option

Some options discussed may require full outages on the bus. Some options may only require outages on individual circuits. Some options may require longer outages to install and test than others.

Because of the criticality of the case study substation bus, Minnesota Power desires the shortest possible outage. For example, the outage duration would be much longer for the percentage restrained differential option because more CT circuits would need to be added to the existing panel, substantially increasing commissioning time. For the high-impedance option (shared CTs), the outage duration can be minimized because only one CT circuit requires wiring to and testing of the relay.

3) Availability of CTs and Cables to Implement a Particular Option

One significant barrier to adding an independent bus protection system is the availability of CTs and cabling to bring CTs from the yard into the relay panel for an added differential relay. Fig. 2 shows a branch circuit breaker connected to a straight bus, as would be the case in the substation shown in Fig. 1. The following subsections examine the various alternative bus protection systems in light of this constraint.

Several alternative assumptions can be made that are relevant to this issue:

1. Every branch circuit breaker has two CTs on the line side of the breaker (Y and Z). These CTs could be available for a redundant protection system.
2. The second set of CTs (Y) is wired and brought into the control building for other purposes, such as metering and supervisory control and data acquisition (SCADA). These CTs could be available for a redundant protection system.
3. The second set of CTs (Y) is not wired to bring into the control building. Making these CTs available for a redundant protection system is likely cost prohibitive.

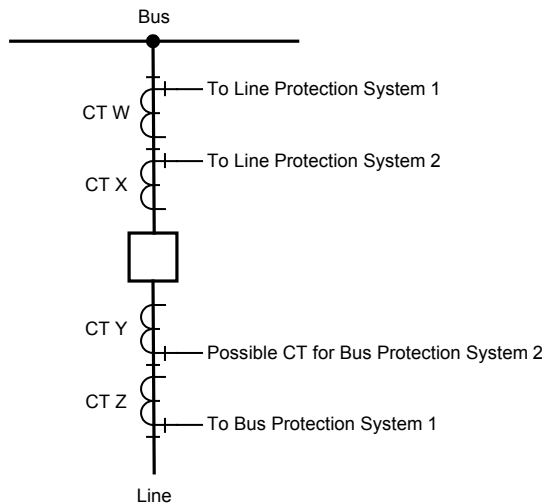

Fig. 2. Branch circuit breaker CTs

B. Option 1: Differentially Connected Overcurrent Scheme

This scheme requires the currents to be summed at a summing junction and a single set of leads in the differential current path to be wired to the relay panel. This requirement mostly precludes using the CTs for multiple purposes, as in the second assumption, because it is not recommended practice to interconnect CTs from multiple circuits to a single CT circuit. On the other hand, this practice can reduce the cost of adding cables if there is a means of adding short cables between each breaker and a nearby summing junction box and between the summing junction box and the control building.

Simple differentially connected overcurrent schemes are generally discouraged because of the relatively poor performance in security and speed. However, this may be considered an acceptable compromise for a backup to the existing primary 87Z protection system.

C. Option 2: Percentage Restrained Differential Scheme

This scheme requires each branch circuit current, the current from CT Y, to be available in the control building. In the past, the CT circuit had to be connected differentially, which restricted its use for other purposes (such as metering and SCADA), as mentioned in Section II. Burden considerations to ensure adequate transient performance also restricted the practice of sharing CTs among multiple applications. However, modern bus differential relays have isolated two-terminal

(six terminals in a three-phase set) CT circuits with the differential current summed mathematically instead of galvanically. Furthermore, modern relays and meters have no appreciable burden, so sharing the CT circuit does not have a significant impact on transient performance. Thus, this option is a possibility.

If the CTs are not used for other applications, as is the situation for the case study substation, existing cables could be repurposed for carrying the CT signals. However, this would require significant redesign of the dc logic wiring between the breaker and the control building with a high degree of risk that not all the branch circuits could be accommodated using this approach.

An alternative is to wire the advanced percentage restrained bus differential relays with two-terminal (six in a three-phase set) CT inputs into the existing branch circuit relaying CT circuits (W or X). This makes use of the CTs on the bus side of the breakers as shown in Fig. 3b. With normal zone overlap as shown in Fig. 3a, there is a nonselective zone where both zones are tripped for faults between the CTs and the interrupter.

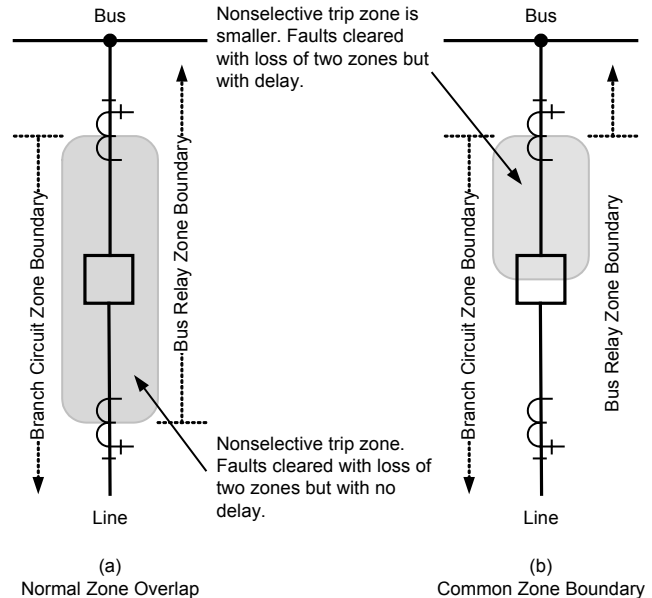

Fig. 3. Normal zone overlap and common zone boundary

The common zone boundary scheme shown in Fig. 3b does not violate the principle of overlapping protection zones in that the boundary between the branch circuit zone and the bus zone is precisely at the location of the shared CT. No fault location is *not* within the zone of protection of one of the two zone protection systems. However, there is a so-called blind zone where the protection zone and the tripping zone do not overlap. A fault between the CT and the interrupter is in the branch circuit protective zone; on the other hand, it is in the bus circuit tripping zone. Therefore, tripping the branch circuit breaker(s) does not clear the fault. This is similar to the common application with live tank breakers that have free-standing CTs on one side of the breaker. With advanced bus differential relays that have zone switching logic, the breaker CT is removed from the bus zone as soon as the breaker opens, which extends the bus-zone boundary to the open interrupter [1]. The

nonselective zone is smaller, but faults in this zone are not cleared as quickly.

D. Option 3: High-Impedance Differential Scheme

This scheme has CT cabling similar to Scheme Option 1. All the same concerns apply.

E. Option 4: Zone-Interlocked Directional Blocking Scheme

This scheme is an option for establishing a redundant bus protection system. It makes use of existing CT circuits and branch circuit relaying. However, it has some significant application constraints. This scheme is only suitable for straight bus applications where the individual branch circuit protection systems are selective in determining that a fault on the branch circuit is not on the bus. However, this scheme cannot be used for bus arrangements with double-breaker branch circuits, such as double-bus/double-breaker and breaker-and-a-half arrangements because the branch circuit relays cannot tell which bus a fault behind them might be on. Furthermore, this scheme requires that all branch circuits have modern relays with programmable logic and, in some cases, communications capability to implement the zone-interlocked protection scheme.

The zone boundary of this scheme is at the bus-side CTs as shown in Fig. 3b. As discussed before, this does not violate the principle of overlapping protection zones in that the boundary between the branch circuit zone and the bus zone is precisely at the location of the CT. In this case, a fault between the CT and the interrupter requires the breaker failure protection system to operate and trip all breakers around the bus. This is the same selection of breakers that would be called upon to trip for a bus fault. Thus, for the small exposure of a fault between the CT and the interrupter, the same breakers will be tripped. However, the tripping will be delayed by the breaker failure time delay. This delay may be considered an acceptable compromise for a backup to the existing primary bus differential protection system.

F. Option 5: Time-Coordinated Relays That Overlap the Bus Zone Scheme

This scheme is presently the backup for the existing case-study scheme. Because this scheme has been deemed inadequate, it is considered no further.

G. Summary of Bus Protection Options

If the second set of CTs (Y) on the branch circuit side of the breaker is brought into the control building for other purposes, these CTs can be used to supply a modern bus protective relay with isolated two-terminal (six terminals in a three-phase set) CT inputs.

A percentage restrained bus differential relay can make use of the branch circuit relay CT circuits to obtain redundant bus protection regardless of the bus arrangement and the branch circuit relaying. Zone switching logic can address coverage of the blind zone between the CT and the interrupter.

If the bus is a straight bus and the branch circuit protection systems are modern relays, a zone-interlocked scheme is a

viable alternative to consider for obtaining independent redundant bus protection. There is a small exposure to delayed tripping (62BF) for a fault between the branch circuit relaying CT and the interrupter.

If the substation has a cable trench system or system of conduits that allows the addition of cables to access the CTs that are presently not in use (Y), any of the protection systems discussed are viable alternatives. An 87Z system can reduce the amount of new cabling required to implement the scheme.

IV. HIGH-IMPEDANCE DIFFERENTIAL PROTECTION

This section discusses the general principle of 87Z relaying to provide a basis of understanding relative to adding redundant 87Z relays in a common CT circuit. The discussion summarizes the theory of operation of the 87Z relaying principle. Section V looks at approaches to provide the redundancy to allow dependability on failure of one of the relays and to allow periodic testing and maintenance of a single relay.

A. 87Z Element Application Considerations

To determine the application considerations for the differential elements in an 87Z relay, it is necessary to understand the basic operation of the system. To implement an 87Z protection system, all CTs defining the bus-zone boundary are summed at a summing junction. The CTs all must have the same CT ratio. The 87Z relay is connected across the summing junction and includes a high-burden impedance in the differential current path (see Fig. 4).

The 87Z scheme works on the principle that, for an external fault, the through current from all sources to a bus drives current through the faulted circuit. The faulted circuit CT may saturate under these conditions and produce a false differential current while the other CTs share this through current and are not as greatly stressed. The 87Z relay includes a high-burden resistor (e.g., 2,000 Ω) in the differential current path that presents a high-impedance path to the flow of this false differential current. On the other hand, the saturated CT presents a low-impedance path for current flow. Therefore, all CTs that are performing well drive the through current to the summing junction, and the current flows through the saturated CT instead of the differential relay.

For an internal fault, all CTs drive current through the high-impedance path, developing a high voltage that rises nearly instantaneously. To prevent damage from the high voltages, a nonlinear resistor, such as a metal-oxide varistor (MOV), is placed in parallel with the burden resistor. The resulting voltage wave appears as a rectangular pulse whose magnitude is the MOV clamping voltage and whose width is a function of the C class of the CTs. The duration of the pulse lasts until a CT saturates and shunts the summing junction until the next zero crossing. The overvoltage 87 element asserts on this nonsinusoidal voltage. To reduce the energy absorbed by the MOV and burden resistor, a contact on the 86B lockout relay shorts the high-impedance element, which then drops out once the impedance is shorted.

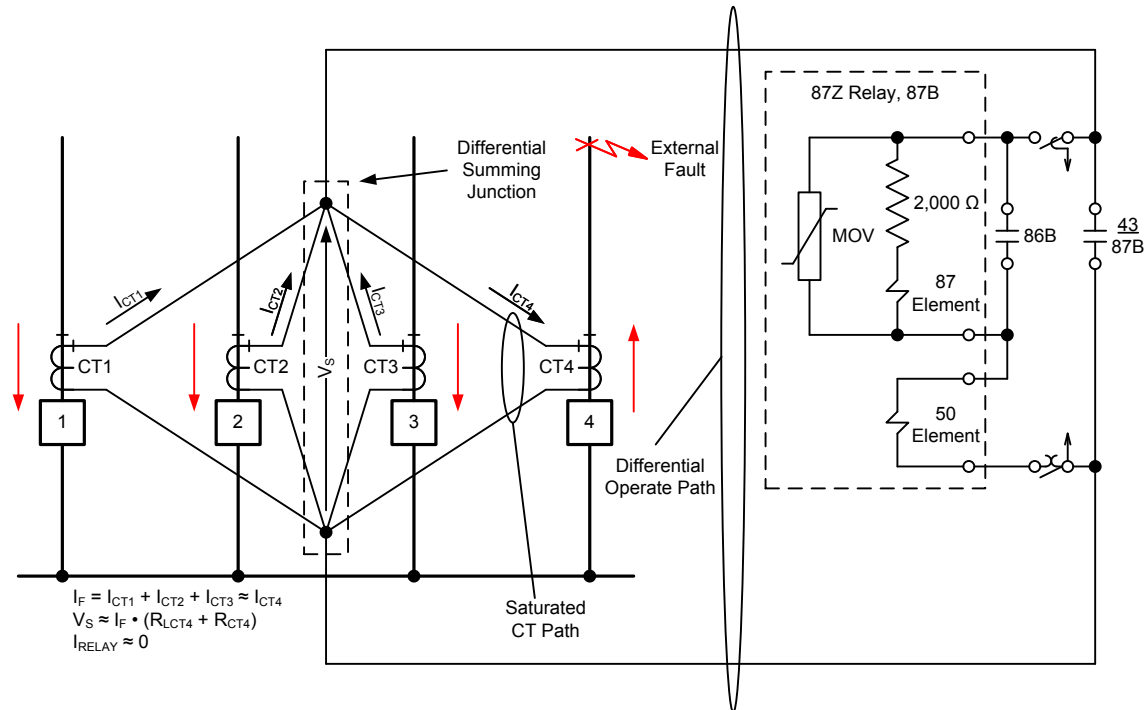

Fig. 4. Bus high-impedance differential protection scheme

Fig. 4 shows a 43/87B differential cutoff switch that Minnesota Power typically includes in their bus differential panels. The 43/87B switch disables the scheme by shorting the 87Z element so that no voltage develops across the relay, preventing a trip.

The following subsections summarize the information contained in [2], including considerations of security, dependability, and 87Z current element application.

1) Security Considerations

For an external fault, the difference currents sum to zero when the CTs perform adequately. If a CT saturates, as mentioned previously, the secondary winding of the CT becomes decoupled from the primary winding. The boundary assumption is that the impedance of the circuit reduces to the burden resistance of the CT windings and leads from the differential summing junction. This path is in parallel with the differential path of the circuit and acts as a shunt for differential current. The 87Z relay has a burden that is several orders of magnitude greater than the saturated CT shunt path so that near-zero current flows to the relay. The lead resistance from the differential summing junction can be ignored as it is in series with the relay burden.

The relay minimum voltage setting (security limit) is based on the boundary condition that one of the CTs saturates entirely for the external fault and produces no secondary voltage. The minimum secure voltage setting is based on the largest voltage drop from the summing junction to the saturated CT [3]. Fig. 5, which is a reproduction of Fig. 3 from [3], illustrates this concept. The following is a summary of the analysis provided in [3]. The reader is urged to consult the cited paper for a more complete discussion.

The four-CT circuit in Fig. 4 is simplified to a two-CT circuit in Fig. 5. CT123 is the equivalent of the three CTs on

the unfaulted circuits. CT4 is the CT on the faulted circuit. The relay set point is based on the voltage at the summing junction. We understand that the assumption that the saturated CT contributes zero voltage to the circuit is unrealistic. But, any contribution that it provides only serves to increase the security margin of the setting (green dashed line).

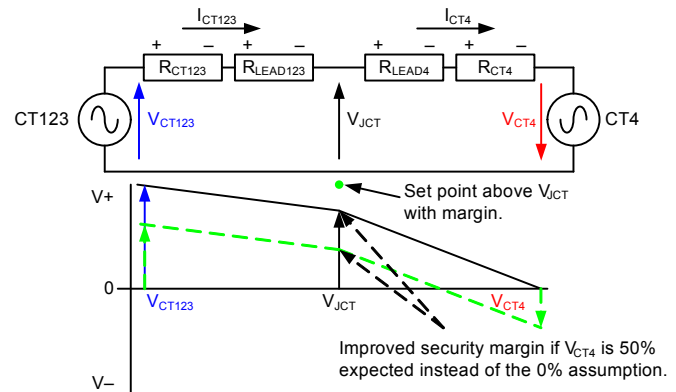

Fig. 5. Voltage at summing junction when faulted CT saturates completely (produces zero volts)

Rigorous analysis includes calculating the burden impedance times the maximum external fault current for each terminal of the bus zone. Typically, a conservative approach is to use the internal fault current (which includes contributions from every terminal) and the largest CT lead length and CT internal resistance.

There is very little security concern for through faults with this type of protection system. However, because of the high sensitivity of this type of protection, differential current caused by some in-zone circuits can result in undesired operation.

One security issue involves in-zone surge arresters that can cause a trip under normal operation when they successfully

conduct to clamp a surge [4]. In applications where the transformer bushing CTs are used (creating the zone boundary) instead of a dedicated transformer breaker, the transformer surge arresters can be in the protection zone and the presence of the arresters should be considered in the relay settings.

Another issue involves faults on the secondary circuit of in-zone station service transformers or voltage transformers [1]. Normally, it is not desired for the bus differential protection to trip before the transformer primary or secondary fuses can clear the secondary fault.

2) Dependability Considerations

For an internal fault, the CTs must drive their ratio current through the burden of the relay. This condition results in all the CTs saturating. The voltage in the circuit is impressed across the secondary winding of the CTs. All the CTs are affected because CT saturation is a function of the integration of the volt-time area at the terminals of the CT [5].

Consider a 20 kA internal fault. With a 400T CT ratio (2000:5), the secondary current through the differential path would be 50 A secondary. With an assumed burden of 2,000 Ω , the voltage across the relay would be 50 A \cdot 2,000 Ω = 100,000 V if the CTs do not saturate. Even with the expected saturation, the voltage developed would be significant. The MOVs connected across the 2,000 Ω burden resistor limit the voltage in the circuit to a level that will not damage the CT insulation, CT cables, terminal blocks, test switches, relay, etc.

One type of 87Z relay offers two options with the maximum clamping voltage specified at 1,500 V_{peak} or 2,000 V_{peak}. High-current laboratory tests [2] [3] showed that the clamping voltage of these two options is approximately 1,000 V to 1,100 V for the MOVs rated at 1,500 V, and 1,400 V to 1,500 V for the MOVs rated at 2,000 V [6]. This clamping voltage is significant to the performance of the relay.

Thus, for an internal fault, the voltage in the circuit goes through the following stages:

1. The voltage rapidly rises to the MOV conduction level. While the curve shape during this rise is sinusoidal, its steepness on the way to 100 kV makes it appear vertical.
2. The MOVs clamp the voltage by conducting the fault current until a CT in the circuit saturates.
3. All the CTs have nearly the same voltage impressed upon them. If they have the same C rating, they will all saturate at nearly the same time. If one of the CTs has a lower C rating, it will be the limiting factor and will saturate when its volt-time area capability is exceeded.
4. Once any CT saturates, the voltage in the circuit drops to nearly zero because the saturated CT effectively shorts the 2,000 Ω burden resistor and MOV. The saturated CTs are no longer coupled to the primary circuit and are therefore no longer driving current in the secondary circuit. However, the shorting effect of the saturated CTs removes the burden from the driving CTs in the circuit, so these CTs come out of saturation and drive their ratio current through the saturated CTs.

5. Once the primary fault current crosses zero, all CTs come out of saturation and the process begins again in the opposite polarity.
6. The resultant voltage signal measured by the relay is a series of positive and negative rectangular pulses with the magnitude determined by the MOV clamping voltage and the width determined by the CT volt-time area capability, which is determined by the C rating.
7. The relay samples this signal and calculates the magnitude. For a faster response, some relays use a half-cycle filter window.

The signal that the differential element of the relay measures for an internal fault is not a function of the fault current level. It is a function of the C rating of the poorest CT in the circuit and the MOV clamping voltage [2]. High-current tests and simulations determined that when a relay with a 2,000 V-rated MOV is used with a C100 CT it produces pulses too short to sample reliably. A C200 CT provides a signal that measures around 400 V and a C400 CT provides a signal that measures around 800 V to the relay [2]. Reference [2] does not provide the voltage level provided by C800 CTs; however, we can conclude that it exceeds the typical maximum relay setting of 800 V.

For very low levels of fault current, we need to perform more detailed analysis. For example, in an impedance-grounded system, the current flowing for an internal fault may not be great enough to cause the MOVs to conduct. The distribution of currents in every branch of the circuit for this low-grade internal fault must be analyzed. As mentioned previously, the voltage in the circuit is impressed upon every CT in the circuit. Thus, the excitation current drawn by these CTs must be considered in determining the minimum current required to trip for an internal fault. In a solidly grounded application, this analysis is not really necessary. Reference [7] provides further discussion on determining minimum sensitivity.

To summarize the dependability concerns, if the setting is greater than 200 V [6], the CTs are rated greater than or equal to C200, and the internal fault current is greater than the minimum required to create greater than 200 V to the relay, then there are no dependability concerns.

B. 87Z Current Element Application Considerations

Fig. 4 shows an overcurrent element in the protection system. This element serves three possible purposes in the scheme:

1. It keeps the relay breaker failure initiate output asserted until all breakers successfully open and the fault is cleared. The voltage element drops out as soon as it is shorted by the 86B contact, but the relay continues to operate as a differentially connected overcurrent scheme.
2. It provides dependable high-speed tripping for situations where an MOV has failed shorted. The relay operates as a differentially connected overcurrent scheme.
3. In applications with breaker bypass switches, it provides bus protection for situations where a branch

circuit breaker is bypassed for maintenance. Prior to bypassing a breaker, the high-impedance element is shorted via a maintenance switch to prevent excessive I^2R heating and false trips from the differential voltage caused by the missing breaker current. The overcurrent element is set above load and operates as a partial differential scheme, open to the circuit on bypass.

To summarize, the overcurrent element provides protection when the high-impedance element is disabled, shorted, or failed. When the scheme is operating normally, the overcurrent element is not required. The third purpose raises the question of whether an overcurrent element can be applied in the proposed dual relay application to cover situations where the high-impedance element is out of service. To consider this, a better understanding of the response of the overcurrent element is required.

Fig. 4 shows the placement of the overcurrent element in the differential circuit. The overcurrent element measures the current in the differential circuit flowing through the burden resistor and the MOVs.

The overcurrent element sees a highly distorted current during an internal fault when the MOVs are in the circuit. Fig. 6 shows the three stages of conduction during an internal fault. For Time A, the MOV is not conducting and the current flows through the $2,000\ \Omega$ burden resistor. For Time B, the MOVs are conducting and current divides between the $2,000\ \Omega$ burden resistor and the MOVs, but the sum flows through the overcurrent element. Once the volt-time area of the CTs is exceeded, the CTs saturate and shunt current away from the relay for Time C until the current crosses zero and unsaturates the CTs.

Time A in Fig. 6 is exaggerated for illustrative purposes. Time A lasts only a few microseconds. The voltage across the $2,000\ \Omega$ resistor rises to a very high level almost immediately. For example, if you have a $10,000\ \text{A}$ bus fault with 400T CTs, the secondary voltage attempts to reach $25\ \text{A} \cdot \sqrt{2} \cdot 2,000\ \Omega = 70\ \text{kV}_{\text{peak}}$. For that case, it will take only $56\ \mu\text{s}$ to reach a $1,500\ \text{V}$ clamping voltage.

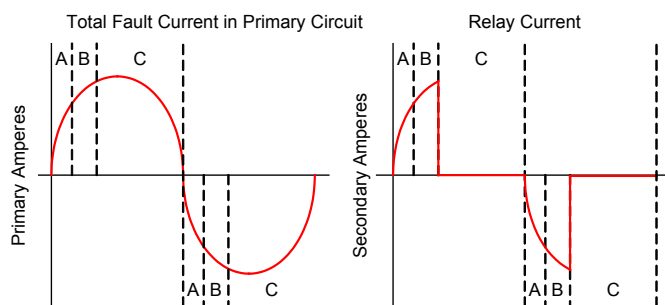

Fig. 6. Currents for an internal fault with 87Z element in service

Fig. 7, which is a reproduction of Fig. 31 in [2], shows the results of a high-current test and confirms the currents illustrated in Fig. 6.

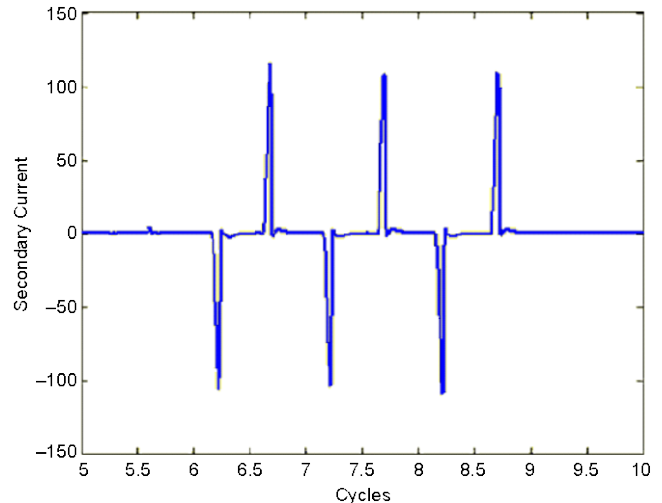

Fig. 7. Differential current for an internal $60\ \text{kA}$ fault with C200 1200:5 CTs [2]

In the case of a fault when the 87Z element is shorted, the current is typically not distorted and resembles the shape of the total fault current in the primary circuit shown in Fig. 6. Thus, the current seen by the relay when the high-impedance element is in service is greatly attenuated from the current seen by the relay when the 87Z element is shorted. We use this understanding of the scheme operation to assess the impact of various configurations of dual 87Z relays in the same CT circuit.

V. DUAL 87Z CONFIGURATIONS

This section examines three options for providing redundant bus protection using the existing 87Z CT circuit in the case study. The options include application of two 87Z relays in a series or parallel configuration. The third option uses a single 87Z relay with a differentially connected overcurrent protection scheme for backup (Scheme Option 1 in Section III).

Because the burden and nonlinear impedance of the MOVs have a significant effect on the waveshape of the current and voltage signals in the circuit, the analysis of the series and parallel arrangements focuses on the effect on the waveshape. Additional items for consideration are the relative complexity of the various circuits and operational flexibility.

The series and parallel circuits also affect the minimum sensitivity of the scheme. However, as explained in the dependability discussion in Section IV, the minimum sensitivity calculation covers faults with currents so low that the MOVs will not conduct. Because the minimum sensitivity is typically several orders of magnitude lower than the minimum fault current, it is not considered further.

A. Series Configuration

Fig. 8 shows a possible arrangement of cutoff switches and test switches for a series configuration. The use of a differential cutoff switch in this configuration is similar to the single-relay application with simply a shorting contact and no need for the complexity of an opening contact with make-before-break switch operation.

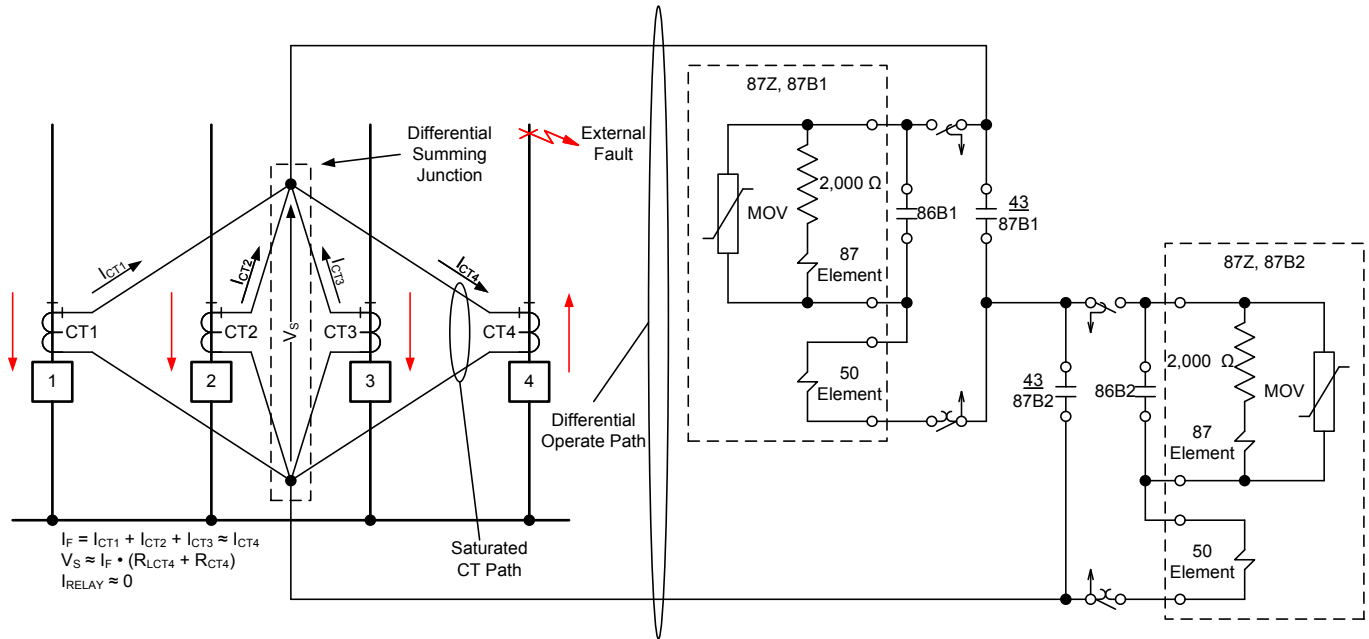

Fig. 8. Series configuration of dual 87Z relays in a common CT circuit

Because the 86B contact is strictly for reducing the thermal impact on the high-impedance circuit components and the application of the 50 element is considered important to the overall scheme, the 86B contact is located inside the CT shorting pair test switch.

If the two relays are connected in series, the MOV clamping voltage impressed upon the summing junction is doubled. This has ramifications on the sensitivity (dependability) of the relay and on the voltage withstand capability of the relay and CT circuit.

1) Impact on Protection Algorithm

The information in [2] can be extrapolated and used to examine the dependability of the scheme with two relays connected in series. The width of the voltage pulses that the relay must sample are a function of the volt-time area of the CTs, which is a function of the C rating of the CT. Doubling the clamping voltage by connecting two MOVs in series reduces the width of the pulse by approximately half. From [2], we know that a C200 CT provides a voltage pulse that is adequate for the relay to sample and obtain a strong voltage magnitude measurement. If we assume that the pulse width of the C800 CTs clamped at twice the clamping voltage would be roughly the same width as that of a C400 CT, the relay should easily trip for an internal fault.

If we use the same logic to examine the application with the poorest CT rated C400, the pulse width would be nearer that of the C200 case. Again, the sensitivity of the relay should be fine. However, if the poorest CT in the circuit is a C200, connecting two relays in series could impair the dependability of the protection system.

Because the minimum recommended voltage threshold is 200 V [6] and the voltage during an internal fault is much higher than this threshold, there is no need to modify the setting based on whether one relay or both relays are in service.

2) Impact on CT Insulation

Doubling the clamping voltage impresses greater stress on the turn-to-ground insulation and the turn-to-turn insulation of the CT, the lead wiring, and the relay. The higher voltage could cause the turn-to-turn insulation inside the CT to fail if windings connected to one terminal of the CT are in close proximity to a winding connected to the opposite end terminal of the CT. Similarly, this high voltage could cause the lead-to-lead insulation between the CT and the summing junction and between the summing junction and the relay to fail if the lead on one terminal is in close proximity to the lead on the opposite end terminal of the CT.

If turns or leads short, damage will occur and the CT and/or wiring will need to be repaired or replaced. However, the main concern is that, if turns are shorted in the secondary windings of the CT, the voltage in the differential circuit will be depressed and the relay may fail to operate, resulting in a dependability failure.

To fully assess the risk of turn-to-turn or lead-to-lead insulation failure, additional information on the voltage withstand capability of the 600 V class insulation used in these CTs and wiring is required. IEEE Standard C57.13-2016, IEEE Standard Requirements for Instrument Transformers [8] includes several clauses that describe the insulation requirements and testing for CTs.

The interturn overvoltage test described in Clause 12.3 is very similar to the conditions that might be expected in this application. This test is not a routine test. It is a type test that is similar to the open-circuit test described in Clause 6.7.1. The voltage of this test is limited to 3,500 V_{peak}. IEEE C57.13 cautions that this test is not to be used to verify the suitability of a CT to be operated with the secondary open-circuited. It states that CTs should never be operated open-circuited because of the potentially dangerous overvoltage and overheating that can occur.

This test level of 3,500 V_{peak} also compares favorably with the expected voltage of $2 \cdot 1,500 \text{ V} = 3,000 \text{ V}_{\text{peak}}$ across the X1 to X5 terminals using two MOVs with 1,500 V clamping voltage in series. Reference [3] provides more in-depth discussion of assessing overvoltage stress in CT circuits applied in an 87Z scheme.

3) Impact on Secondary Wiring Insulation

To fully assess the risk of lead-to-lead insulation failure, additional information on the voltage withstand capability of the 600 V class insulation used in the wiring is required. DC high-potential tests can be used to assess the ability of the wiring and terminal blocks to withstand the higher than normal overvoltages in the circuit for the series configuration. A typical value for dc high-potential testing is two times the insulation class plus 1,000 V times $\sqrt{2}$. So for 600 V insulation, 3,111 V would be applied.

B. Parallel Configuration

Fig. 9 shows an arrangement of cutoff switches and test switches for a parallel configuration. This configuration requires a 43/87B differential cutoff switch to short the high-impedance elements and open a contact to disconnect the high-impedance element in case the relay is isolated via the current shorting test switch. The parallel arrangement requires the added complexity that the cutoff switch be specified with make-before-break switch operation.

Because the 86B contact is strictly for reducing the thermal impact on the high-impedance circuit components, the 86B contact is located inside the CT shorting pair test switch. This simplifies the circuit so that an additional contact to open the 86B shorting contact via the 43/87B switch is not required. And, because the application of the 50 element is considered important to the overall scheme, these elements are connected

in series and require a separate set of current shorting test switches.

In this configuration, operating the differential cutoff switch does not completely disable its differential relay because the 50 element is still in the circuit. This arrangement assumes that the reason to disable one relay and not the other is to perform maintenance and testing on the disabled relay. In this case, technicians isolate both elements of the relay with the test switches.

The two 43/87B shorting contacts in series around the whole circuit keep the circuit safe when both differential cutoff switches are operated and will completely disable the scheme. This arrangement has the additional complexity that each 43/87B switch must have make-before-break action to prevent open-circuiting the CT circuit under some configurations. If it is desired that the 50 element also be disabled by the differential cutoff switches when operated singly, this can be accomplished by wiring a status input to the 87Z relay to block tripping by the 50 element. It is not necessary to short and isolate the overcurrent element to prevent I^2R heating as is the case with the 87Z element.

1) Impact on Protection Algorithm

If the two relays are connected in parallel, the MOV clamping voltage impressed upon the summing junction and paralleled CTs is no different than the single-relay application. Thus, the parallel configuration has no material impact on the sensitivity (dependability) of the relay. The current during Time A + B of the internal fault, as defined in Fig. 6, simply divides between the MOVs in the two relays, which reduces the I^2t heat buildup in these components during an internal fault. As stated previously, we are not concerned about the minimum sensitivity of this scheme in this application.

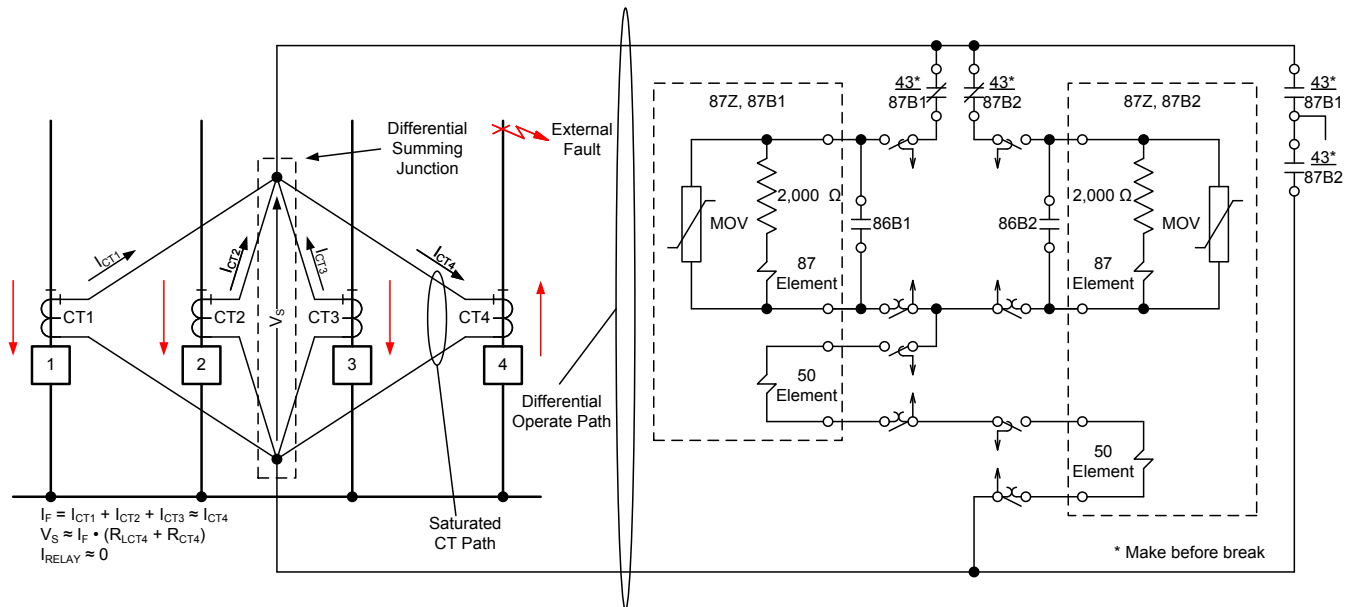

Fig. 9. Parallel configuration of dual 87Z relays in a common CT circuit

2) Impact on Insulation

If the two relays are connected in parallel, the MOV clamping voltage impressed upon the summing junction is no different than the single-relay application. Thus, the parallel configuration has no impact on the voltage withstand capability of the circuit.

C. Differential Overcurrent Backup Configuration

As discussed in Section III, simple differentially connected overcurrent schemes are generally discouraged because of the relatively poor performance in security and speed. Modern high-performance differential relays are economical to the point that there is now little financial incentive to choose this option. However, the reduction of CT circuit complexity this option provides makes it worth consideration in this case.

Fig. 10 shows an arrangement of cutoff switches and test switches using a differentially connected overcurrent scheme (50/51) as the redundant protection system. This configuration removes all concerns about reduced sensitivity and higher voltage associated with the series configuration and considerably reduces the complexity of the circuit associated with the parallel configuration.

Before analyzing the impact on protection, it is necessary to understand the application of differentially connected overcurrent protection. Annex C of [1] provides a discussion of how this protection is applied. In an unrestrained differential scheme, security is obtained through the use of an inverse timing element, as opposed to a percentage restrained differential element that automatically provides a higher pickup threshold the larger the through current is in the bus.

The inverse timing element is typically a short-time inverse curve. This curve is set based on the idea that the false

differential current is relatively small compared to the current when an internal fault occurs. For an external fault, the multiple of pickup is low and the delay allows the relay to ride through the external fault until the CT recovers from asymmetrical saturation. For an internal fault, the multiple of pickup is high and the inverse-time element does not introduce a large delay in tripping. One reason that this scheme is not generally recommended is that the settings criteria for the pickup and time delay tend to be based on engineering judgment and rules of thumb, as opposed to engineering analysis. Annex C of [1] provides suggested application criteria.

In this application, when the 87Z relay is in service, the high-impedance element prevents false differential current from flowing to the relay during an external fault. Therefore, this configuration does not require a delay to ride through the false differential current.

1) Analysis of CT Performance When MOVs Are Out of Service

When an MOV is shorted, the system operates as an unrestrained differential overcurrent scheme. Thus, it is a good idea to assess CT performance. The CTs were analyzed using the techniques described in [9] for the case study substation. The conservative assumption using the largest CT length and the highest internal fault current was used. The worst-case CT saturation voltage, V_s , was calculated as 21.3. This result is for a 20,620 A single-line-to-ground fault with an X/R ratio of 9.5 (angle = 84°) using a 2000:5 C800 CT. The calculation determines that saturation can occur if V_s is greater than 20. Thus, with a result of 21.3, false differential current from CT saturation is possible and should be considered. However, the result is only marginally above the limit, so saturation is not expected to be severe.

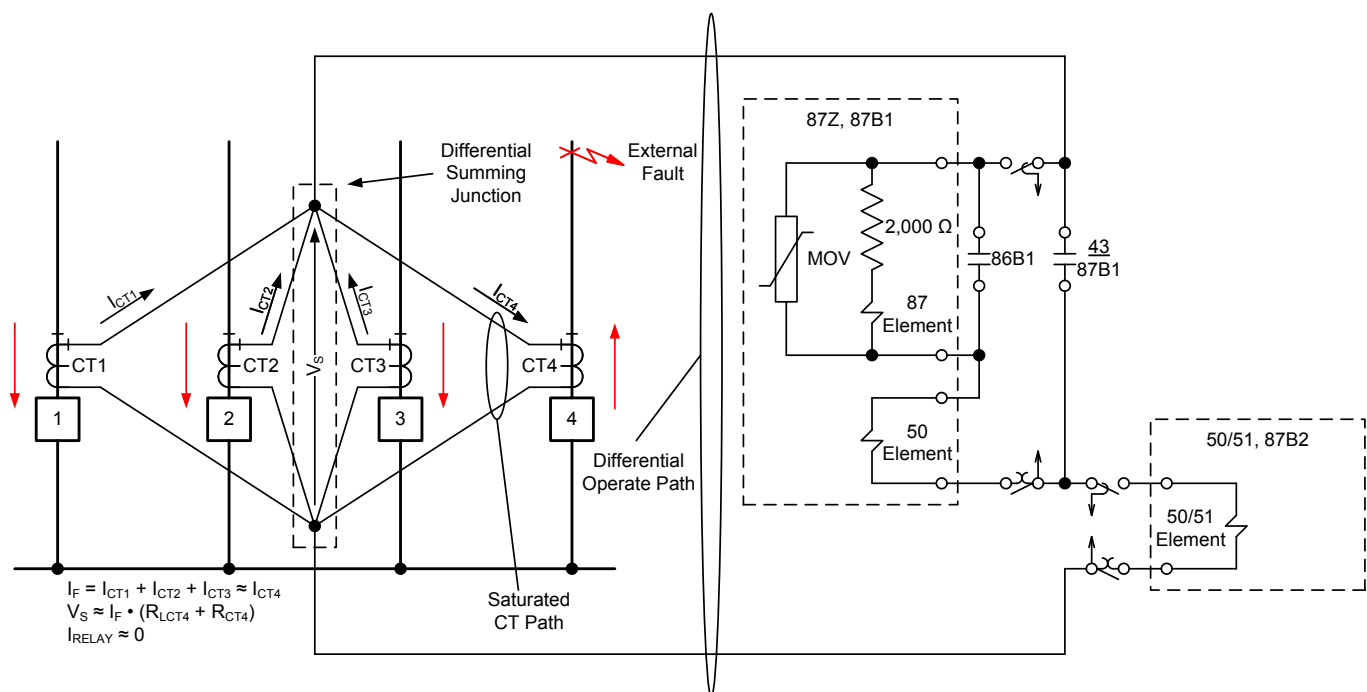

Fig. 10. Application with differentially connected overcurrent relay to provide redundancy

2) Analysis of Attenuation With MOVs in Service

This subsection includes analysis of the expected attenuation of the current signal to determine if the 50/51 element can be set to trip when the MOVs are in service.

A simulation of the relay's full-cycle cosine (COS) filtering algorithm was used to determine the expected degree of attenuation for the distorted waveform.

The distorted waveform was constructed using the following procedure:

1. The maximum and minimum fault current magnitudes and X/R ratios for internal bus faults were obtained, as shown in Table I.
2. The volt-time area of a C800 CT was interpolated based on data from Fig. 39 of [2]. A pulse width of $2.34 \text{ ms} \cdot 2 = 4.68 \text{ ms}$ was used in the simulation to determine the current seen by the relay before the CTs saturate and shunt current away from the relay. The data in Fig. 39 are for a relay with 2,000 V MOVs (with actual clamping voltage of 1,500 V).
3. Point on wave (POW) was varied from $+90^\circ$ to -90° in 30° increments to simulate the effect of the dc transient on the distorted waveform.
4. Faults were simulated for 2000:5 CTs.

TABLE I
FAULT DATA

Fault Type	Magnitude	Angle	X/R Ratio
Single-line-to-ground, maximum	20,620 A	-84°	9.5
Line-to-line, minimum (N-0)	15,033 A	-84°	9.5
Line-to-line, minimum (N-1)	10,415 A	-84°	9.5

For example, the waveform for a fault with X/R ratio of 9.5 at -30° POW with 4.68 ms pulse width is shown in Fig. 11. The sum wave is the summation of the sine wave and the exponential signal. The relay current signal is the current let through the MOVs until the CTs all saturate and short the summing junction. The scale is in per unit of peak of the symmetrical sine wave.

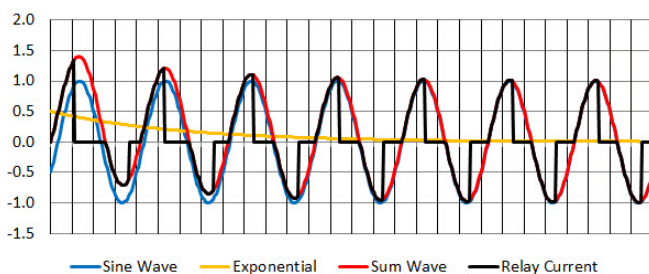

Fig. 11. Simulated waveform for 20,620 A fault at -30° POW and 4.68 ms pulse width

The relay current waveform was sampled at 16 samples per cycle and filtered to obtain the magnitude of the distorted waveform. Fig. 12 shows the filtered magnitude of the waveform in Fig. 11.

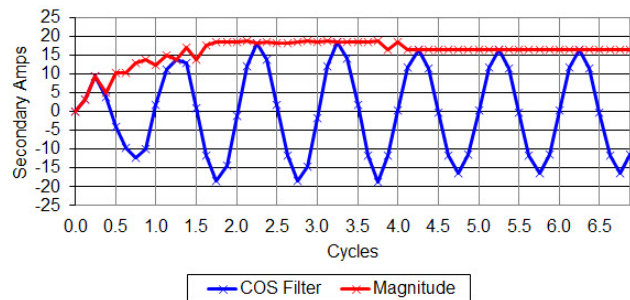

Fig. 12. Filtered current, CT ratio = 400T

The magnitude for each simulation was compared to the magnitude of the undistorted waveform (87Z element shorted) to determine the degree of attenuation caused by the high-impedance element and the relay COS filter.

For the 20,260 A fault, the ratio current is approximately 50 A secondary. The lowest attenuated magnitude from the simulation was 32 A. Similarly, for the 10,415 A fault, the ratio current is approximately 26 A secondary. The lowest attenuated magnitude from the simulation was 16.6 A. Thus, it was determined that the 50 element in the 87Z relay and the 50/51 relay would be attenuated around 64% by the high-impedance elements in the differential circuit—assuming C800 CTs and an MOV with 1,500 V clamping level. Lower-rated CTs would provide a narrower pulse width and greater attenuation.

D. Settings Criteria for 87B2, Differentially Connected Overcurrent Element

This subsection evaluates the settings criteria for the 50/51, 87B2 relay using a series of equations. Ideally, the relay will be dependable for the minimum fault with the MOVs in service and secure for the maximum fault with the MOVs shorted.

1) Security

Following the guidelines in [1], the pickup was set with five times margin for N-0 conditions and three times margin for N-1 conditions. The minimum fault current was used for each condition in the following calculations:

$$51\text{PU}_{\text{N-0}} < \frac{15,033 \text{ A}}{5} = 3,007 \text{ A}$$

$$51\text{PU}_{\text{N-1}} < \frac{10,415 \text{ A}}{3} = 3,472 \text{ A}$$

$$51\text{PU} = 3,000 \text{ A}$$

$$51\text{PU}_{\text{Secondary}} = 51\text{PU} \div 400\text{T} = 7.5 \text{ A}$$

A short-time inverse curve was used and a time dial was selected to provide four-cycle operation at three times pickup. The time to trip equation shown here is from [6]:

$$\text{TD} = \frac{4 \cdot 0.0167 \text{ s}}{\left(0.00262 + \frac{0.00342}{3^{0.02} - 1}\right)} = 0.43$$

2) Performance

The time to trip for the minimum fault with the MOVs in service was calculated as shown here:

$$T_p = TD \cdot \left(0.00262 + \frac{0.00342}{\left(\left(64\% \cdot \frac{10,415 \text{ A}}{51\text{PU}} \right)^{0.02} - 1 \right)} \right) \cdot \frac{60 \text{ cyc}}{\text{s}}$$

$$= 5.5 \text{ cyc}$$

Determine the time to trip for the minimum fault with the MOVs shorted as follows:

$$T_p = TD \cdot \left(0.00262 + \frac{0.00342}{\left(\left(100\% \cdot \frac{10,415 \text{ A}}{51\text{PU}} \right)^{0.02} - 1 \right)} \right) \cdot \frac{60 \text{ cyc}}{\text{s}}$$

$$= 3.5 \text{ cyc}$$

Determine the time to trip for the maximum fault with the MOVs in service as follows:

$$T_p = TD \cdot \left(0.00262 + \frac{0.00342}{\left(\left(64\% \cdot \frac{20,620 \text{ A}}{51\text{PU}} \right)^{0.02} - 1 \right)} \right) \cdot \frac{60 \text{ cyc}}{\text{s}}$$

$$= 3.0 \text{ cyc}$$

Determine the time to trip for the maximum fault with the MOVs shorted as follows:

$$T_p = TD \cdot \left(0.00262 + \frac{0.00342}{\left(\left(100\% \cdot \frac{20,620 \text{ A}}{51\text{PU}} \right)^{0.02} - 1 \right)} \right) \cdot \frac{60 \text{ cyc}}{\text{s}}$$

$$= 2.3 \text{ cyc}$$

E. Summary

The series configuration can be applied with C400 or C800 CTs with adequate dependability. The circuits are subjected to higher peak voltages during an internal fault. However, the voltages are likely within the insulation capabilities of the circuit components. Specifying an 87Z relay with the 1,500 V maximum clamping voltage MOVs would decrease the voltage stress in the series configuration versus specifying a relay with the 2,000 V MOV option. The series configuration provides a less complex configuration of test switches and differential cutoff switches compared to the parallel configuration.

The parallel configuration can be applied with no additional minimum CT class constraints or concerns about excessive voltage stress on the circuit components. In the parallel configuration, a shorted MOV disables the voltage elements in both relays, making the scheme rely on the 50 elements for protection for that single point of failure. The parallel configuration provides a more complex configuration of test switches and differential cutoff switches.

A differentially connected overcurrent relay can be applied for redundancy with adequate security and slightly slower performance. For cases with the 87B1 relay in service, the attenuation of the current signal caused by the high-impedance elements of the circuit results in a lower multiple of pickup of the short-time inverse tripping element, which results in a longer time to trip. However, in that case, the 87Z, 87B1 relay can trip in normal time. If the 87Z, 87B1 relay is disabled using the 43/87B1 differential cutoff switch, the tripping times for the 50/51, 87B2 relay improve significantly. This slight compromise in performance of the backup relay greatly simplifies the CT circuit configuration.

Alternatively, wiring the status of the 43/87B1 differential cutoff switch to an input on the 50/51, 87B2 relay improves performance. This status would be used to enable a 50 element when the 87Z, 87B1 relay is in service. The 51 element would be used to enhance security when the high-impedance element is shorted and the system operates as a differentially connected overcurrent scheme.

VI. IMPLEMENTED SOLUTION

Minnesota Power decided to pursue the third option of combining 87Z and differentially connected overcurrent protection in a common CT circuit as shown in Fig. 10.

We assessed the alternatives and chose this option because it met the needs for redundancy and for the simplicity of the CT circuit as compared to the other options. Minnesota Power did decide to wire the status of the 43/87B1 differential cutoff switch into the 50/51, 87B2 relay to improve performance by switching from a 50 element to a 51 element when the high-impedance element is shorted, as mentioned previously.

Minnesota Power evaluated all the options discussed previously in this paper and ran into multiple contingencies that lead to the decision to apply an 87Z and differentially connected overcurrent scheme. First, connecting the redundant relaying to a second CT circuit was ruled out as an option early in the project for the following reasons:

- Space constraints inside the control house ruled out the option to apply a low-impedance differential relay for redundancy. The control house does not have room to accommodate the additional panel that would be required.
- Applying another high-impedance differential relay as a redundant relay was also determined not an option because, though the spare set of breaker CTs are all C800 class, three different full-tap ratios exist on the spare CT set.

Before deciding on one of the dual 87Z configurations, Minnesota Power reviewed the zone-interlocked directional blocking scheme discussed in Section III (Scheme Option 4). This control scheme was rejected because of its complexities. When considering this scheme for redundancy, relaying outages on line panels also needed to be considered. These outages could be a result of maintenance or relay failure.

After evaluating all the redundant high-impedance relay schemes discussed in this paper, Minnesota Power came to the following conclusions:

- The 87Z series configuration was rejected because of the concerns of the increase in built-up voltage causing damaging CT cable insulation stress.
- In regard to redundancy, Minnesota Power's primary goal was to seek a solution that would guarantee to clear a bus fault before the line remote ends would clear the fault—any increase in speed was a bonus. All the 87Z options met this requirement. Based on this conclusion, both the parallel 87Z configuration and differentially connected overcurrent configuration remained options.
- Minnesota Power decided to apply the differentially connected overcurrent relay configuration instead of the parallel 87Z configuration because of the simplicity of the CT circuit in the differentially connected overcurrent option. Their theory is the simpler the circuit is, the less chance of human error that would lead to an unintended relay operation.

At the end of this study, the need for relaying redundancy was met. Deciding to apply the differentially connected overcurrent relay scheme meant a compromise of CT circuit redundancy. Minnesota Power determined this compromise to be acceptable because of the project contingencies.

VII. CONCLUSION

Redundant bus protection systems were rarely applied in the past, but new NERC requirements make it necessary to assess the impact on the reliability of the BES of any single point of failure. This can be a time-consuming task that must, at times, be performed with little notice. Thus, improving protection schemes to provide dual selective high-speed bus protection schemes is becoming more important.

The paper provided a review of bus protection methods and assessed their acceptability for obtaining redundancy in a retrofit application. Each scheme has constraints that may rule them out in a particular application. The paper delved into the question of how to apply dual 87Z type relays in a common CT circuit. This option has few constraints as it uses the existing CT wiring and requires minimal additional panel space.

Our investigation examined both series and parallel configurations of the relays and concluded that either configuration could be used. But, each has its own pros and cons that must be assessed. The third option of combining 87Z and differentially connected overcurrent protection in a common CT circuit was also examined and ultimately chosen for this project.

VIII. REFERENCES

- [1] IEEE Standard C37.234-2009, IEEE Guide for Protective Relay Applications to Power System Buses.
- [2] S. E. Zocholl and D. Costello, "Application Guidelines for Microprocessor-Based, High-Impedance Bus Differential Relays," proceedings of the 62nd Annual Conference for Protective Relay Engineers, College Station, TX, March 2009.

- [3] R. Franklin, H. Nabi-Bidhendi, M. J. Thompson, and H. J. Altuve, "High-Impedance Differential Applications With Mismatched CTs," proceedings of the 44th Annual Western Protective Relay Conference, Spokane, WA, October 2017.
- [4] K. Koellner, O. Reynisson, and D. Costello, "High-Impedance Bus Differential Misoperation Due to Circuit Breaker Restrikes," proceedings of the 67th Annual Conference for Protective Relay Engineers, College Station, TX, March 2014.
- [5] S. E. Zocholl and D. W. Smaha, "Current Transformer Concepts," proceedings of the 46th Annual Georgia Tech Protective Relaying Conference, Atlanta, GA, April 1992.
- [6] SEL-587Z Instruction Manual. Available: <https://selinc.com>.
- [7] K. Behrendt, D. Costello, and S. E. Zocholl, "Considerations for Using High-Impedance or Low-Impedance Relays for Bus Differential Protection," proceedings of the 49th Annual Industrial & Commercial Power Systems Technical Conference, Stone Mountain, GA, April 2013.
- [8] IEEE Standard C57.13-2016, IEEE Standard Requirements for Instrument Transformers.
- [9] M. Thompson, R. Folkers, and A. Sinclair, "Secure Application of Transformer Differential Relays for Bus Protection," proceedings of the 58th Annual Conference for Protective Relay Engineers, College Station, TX, April 2005.

IX. BIOGRAPHIES

Josh LaBlanc received his B.S. of Electrical Engineering from the University of North Dakota in 2011. Upon graduating, he served two years as a power systems engineer for an oil and gas pipeline company, Enbridge Energy. The next four years, he worked as a relay and maintenance engineer at Minnesota Power. Josh joined Schweitzer Engineering Laboratories, Inc. in January 2018 as an application engineer. He is a registered professional engineer in the state of Minnesota.

Michael J. Thompson received his B.S., magna cum laude, from Bradley University in 1981 and an M.B.A. from Eastern Illinois University in 1991. Upon graduating, he served nearly 15 years at a public utility, Central Illinois Public Service (now AMEREN). Prior to joining Schweitzer Engineering Laboratories, Inc. (SEL) in 2001, he was involved in the development of several numerical protective relays while working at Basler Electric. He is presently a fellow engineer at SEL Engineering Services, Inc. He is a senior member of the IEEE, member of the IEEE PES Power System Relaying and Control Committee (PSRCC), past chairman of the Substation Protection Subcommittee of the PSRCC and received the Standards Medallion from the IEEE Standards Association in 2016. Michael is a registered professional engineer in six jurisdictions, was a contributor to the reference book, *Modern Solutions for the Protection, Control, and Monitoring of Electric Power Systems*, has published numerous technical papers and magazine articles, and holds a number of patents associated with power system protection and control.

Previously presented at the 2018 Texas A&M Conference for Protective Relay Engineers.

© 2018 IEEE – All rights reserved.
20180213 • TP6826-01