

# Case Study: High-Density Distribution Coordination Using High-Speed Communications

Robert M. Cheney and John T. Thorne  
*Alabama Power*

Robert Van Singel, Andrew Hanson, Chris Anderson, and Joshua Hughes  
*Schweitzer Engineering Laboratories, Inc.*

Presented at the  
47th Annual Western Protective Relay Conference  
Virtual Format  
October 20–22, 2020

Original edition released April 2020

# Case Study: High-Density Distribution Coordination Using High-Speed Communications

Robert M. Cheney and John T. Thorne, *Alabama Power*  
 Robert Van Singel, Andrew Hanson, Chris Anderson, and Joshua Hughes,  
*Schweitzer Engineering Laboratories, Inc.*

**Abstract**—An increased density of protective devices on distribution networks can help improve reliability metrics by reducing the number of utility customers within any isolation zone. However, traditional relaying coordination methods become increasingly difficult to implement as the total number of devices increases. To maintain security and selectivity, traditional protection requires additional time delays for each sequential protective device, thus increasing the time that fault current is present on the system. This case study focuses on Alabama Power and how an advanced coordination scheme, not limited by traditional coordination considerations, was developed leveraging their high-speed communications infrastructure.

This advanced distribution-level coordination scheme, built on IEC 61850, uses topology-based coordination rather than traditional time-curve and directional coordination. This approach combines local knowledge of fault current presence and peer-based communications to quickly determine the closest up-line device to the fault location and interrupt the fault within 7 cycles, regardless of fault location within the network. In addition, this method removes the need for traditional coordination of each protective device and provides secure operation under changing system conditions (and any feeder configuration), independent of system density.

## I. INTRODUCTION

In the ongoing quest to reduce power outages and the number of utility customers affected by outages, one solution is to increase the number of fault-interrupting devices within a system. This decreases the physical size of individual protection zones, reducing the number of utility customers in each zone.

Smaller zones increase reliability in several ways; for example, fewer customers are impacted during a fault. However, the higher number of protective devices complicates traditional protection schemes. Using traditional protection with standard coordination between curves limits the maximum number of protective devices bounded by the protection operating speed and transformer damage curves, as shown in Fig. 1.

Although additional devices may be added if the delay between the curves of sequential devices is reduced, as shown in Fig. 2, doing so greatly increases the risk of protection miscoordination, defeating the purpose of added protective devices. This problem intensifies for interconnected networks, where systems are not always in normal configuration and coordination studies must be performed for multiple power flows.

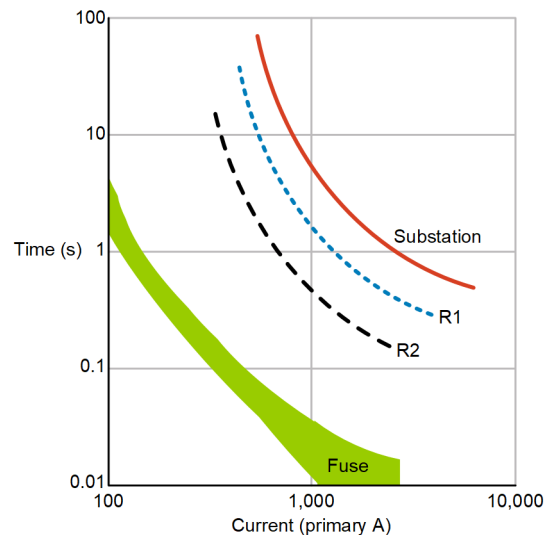

Fig. 1. Traditional coordination for high-density distribution. The maximum number of devices is limited by the substation damage curve and protection operating speed.

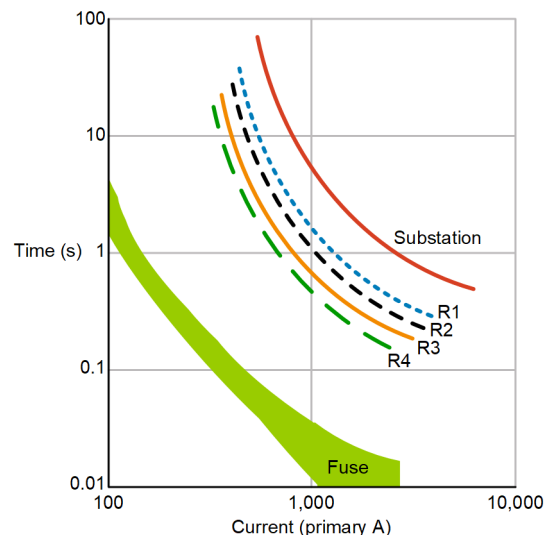

Fig. 2. Compressed coordination for high-density distribution. Additional protective devices may be added if the coordination margins are reduced but doing so increases the risk of protection miscoordination.

In these situations, peer-to-peer communications-based protection schemes can resolve many of the issues with traditional coordination schemes. High-speed communications protocols, such as IEC 61850 Generic Object-Oriented

Substation Event (GOOSE), allow a system to maintain a consistent operating interval, regardless of system size or depth of operating devices. However, maintaining protection-speed operations using a communications-based scheme requires a fast, reliable, and deterministic network that supports Ethernet protocols. For this reason, the most likely medium for implementation is fiber-optic Ethernet. Radio or cellular networks may be a feasible alternative only if fast, deterministic data delivery and cybersecurity can be guaranteed.

Alabama Power implemented a new communications-based coordination scheme that leverages a Gigabit Passive Optical Network (GPON) for utility communications. The power system topology consists of a single substation on the south side of Birmingham, Alabama with four distribution feeders. A total of 33 control devices are involved in the coordination scheme: the 4 substation feeder breakers and 29 recloser controls across feeders. The recloser control density on each feeder varies from 2 to 15 recloser controls each.

Alabama Power identified several objectives for the system. They required a high-density distribution coordination (HDC) scheme to provide the following:

- Identification of the faulted line segment, with tripping blocked on all other line sections within 3 cycles.
- Interoperability with various commercial off-the-shelf (COTS) devices that support custom protection logic.
- Simplicity of design and settings development.
- Ease of deployment.
- Ease of expansion and modification.
- Ease of field testing of network, device, and GOOSE configurations.

## II. HDC SCHEME

### A. Protection Blocking Scheme

To circumvent the limitations of traditional coordination, the HDC scheme blocks fast overcurrent element operation if a protective device receives at least two fault-detection notifications from neighboring protective devices within a 3-cycle coordination margin. If the protective device receives no indication or only one indication, then the fast overcurrent element may operate.

As backup to the HDC scheme, traditional protection with coordination is implemented across the protective devices, using larger zones and with some devices acting as switches or sectionalizers in case of a communications failure or another unanticipated event.

In the HDC scheme, each protective device that senses elevated fault current publishes a block signal on the network. In addition, each protective device subscribes to blocking signals from all electrically adjacent devices in both directions. An example of this subscription model is shown in Fig. 3.

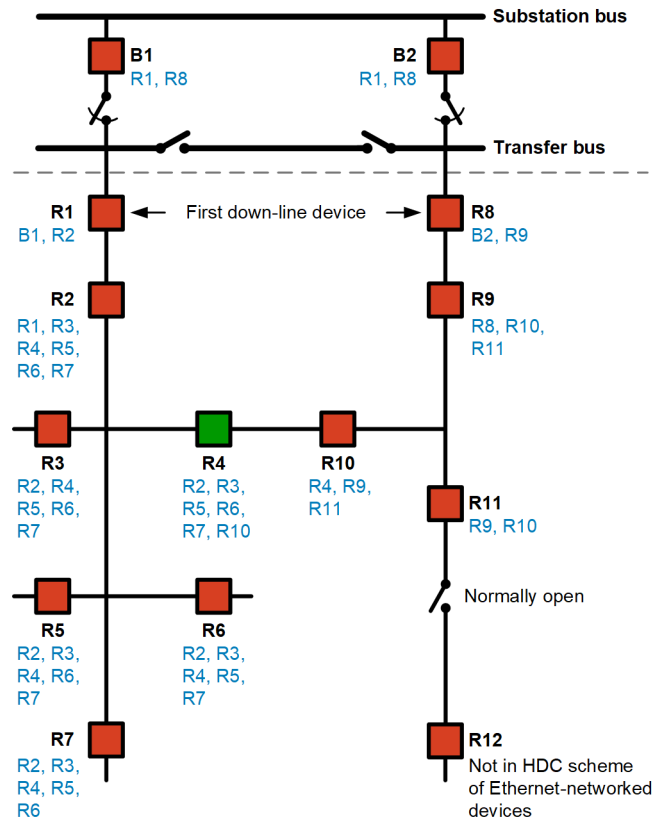

Fig. 3. Example HDC subscription model with subscriptions shown in blue.

If a device receives more than one block indication from adjacent devices, it cannot be electrically closest to the fault, because one of the two indications must be down-line of the device. The presence of two block signals is therefore used to block tripping of the fast overcurrent element for the device.

The device closest to the fault receives only one block signal, because the adjacent protective device down-line does not see any fault current. Fig. 4 shows a simple fault block illustration in which the protective device at Recloser R2 trips on the fast overcurrent element, because it received only a single block. The device at Breaker B1 does not operate on the fast overcurrent element due to a modified blocking scheme for source devices (described in Section III).

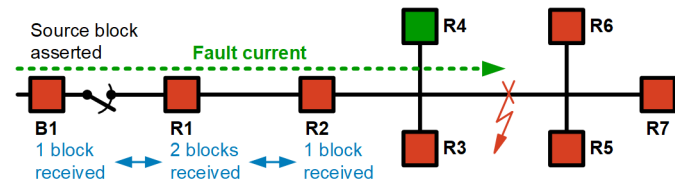

Fig. 4. Blocking signal propagation.

In this protection scheme, all protective devices can be configured for a single uniform pickup threshold and time delay

for HDC operation, regardless of position within the system or system depth. The protection coordination curves for this scheme are shown in Fig. 5. The substation curve is a backup protection curve; feeder breakers operate using the HDC fast trip curve for most operations. As a result, traditional coordination settings development is no longer necessary, and a standardized template can be used at all line-device locations.

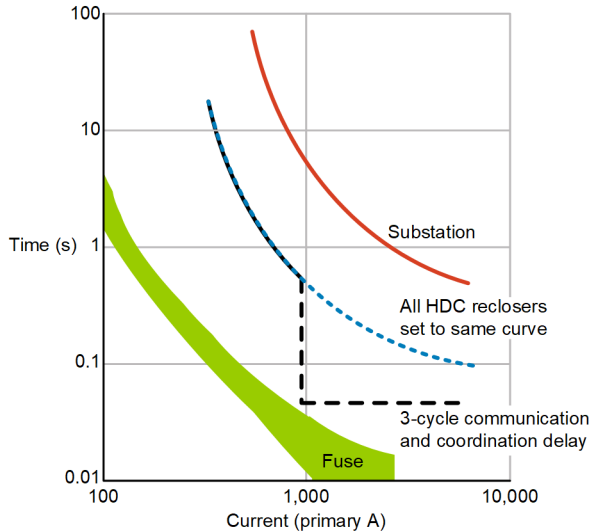

Fig. 5. HDC scheme operating curves. Operating times are independent of the total number of devices in the system. The improvement with this scheme is visible in comparison with the curves in Fig. 1 and Fig. 2.

### B. Interoperability

To allow interoperability with multiple types of COTS recloser controls, each installation contains both a recloser control and a programmable logic controller (PLC). The PLC contains all the logic for performing the HDC blocking scheme and communicating with neighboring units using GOOSE, as well as communicating with the specific recloser control. The recloser control contains pickup elements for triggering a block on fault current detection, as well as timing for receiving blocks from neighboring devices.

This separation of responsibility means that only the PLC must be configured for the system topology, while the recloser control only needs to communicate with the local PLC. PLCs have the advantage of more advanced logic than most recloser controls, allowing for settings that can automatically adjust to accommodate the number of adjacent protective devices. This combination allows for a standard settings file for each recloser control and a standard settings file for each PLC, based on the connected device and the substation configuration description (SCD) file that defines the communications topology of the scheme. In addition, this allows for protective devices that do not support IEC 61850 GOOSE to participate in the scheme.

These protective devices can use either a high-speed communications protocol or hardwired inputs and outputs that connect to the local PLC.

### C. IEC 61850 Configuration

One objective in this case was to keep IEC 61850 settings development and deployment simple, because this step is not required for traditional protection coordination.

For the system blocking scheme, only Boolean logical values need to be transmitted between devices. To simplify mapping of data sets and values between systems, these Boolean values are bit-packed into a standard 32-bit integer supported by IEC 61850, so the data set transmitted between neighbors consists of only that single 32-bit integer. The subscribed neighboring devices require configuration only to receive a single 32-bit integer from each neighbor. For example, configuration of the device at Recloser R1 in the example system requires the reading of one integer from the device at Breaker B1 and one integer from the device at Recloser R2. An example of the complete IEC 61850 receiving configuration in an intelligent electronic device capability description (ICD) configuration software is shown in Table I.

TABLE I  
BLOCKING SCHEME GOOSE RECEIVED VALUES FOR RECLOSER R1

Integer	Source Data Item	Description
INS001.stVal	B0001/CFG/LLN0/Blocks.HDC.GGIO1.IntIn001.stVal	B0001 HDC blocking signals
INS002.stVal	R0002/CFG/LLN0/Blocks.HDC.GGIO1.IntIn001.stVal	R0002 HDC blocking signals

### D. Changes to System Operating Principles

Another objective for this system was to minimize changes to field operating behaviors. Such changes can require field technician retraining or changes to existing operating procedures.

To this end, the scheme was designed to have no impact on normal operating procedures. The scheme automatically adapts for changes in the device open/closed status and requires no changes in switching procedures. The PLC requires no interaction following initial installation and configuration. Indicators can be added later to the PLC or protective devices to indicate system-armed or communications-failure statuses.

## III. SPECIAL CASE DESIGN

### A. Source Devices

The blocking scheme relies on the assumption that devices exist both up-line and down-line of a device (for detecting when

a fault is outside of the device zone). This logic works for units with devices both up-line and down-line and for devices at the end of radial feeds.

For a device situated at the start of the HDC network with devices only down-line, a fault beyond the local zone results in only a single block. This behavior is corrected by considering such devices to have a local block constantly asserted. Therefore, the device requires only one external block to prevent local high-speed operation.

In this specific implementation, the logic is implemented as a user setting and enabled by default for feeder breakers.

### B. Integration With Traditional Coordination Networks

Devices that border traditional protection schemes require special consideration. Depending on the power flow direction, these devices have HDC devices either up-line (in the case of power export) or down-line (in the case of power import) but not in both directions.

To account for this, edge devices have a local block constantly asserted, similar to source devices. The following two subsections describe operating behaviors under this condition.

#### 1) Fault Beyond the HDC System During Power Export

For a fault beyond the HDC system being fed through the HDC system, the edge device receives one external block which, combined with the local block, prevents local high-speed operation. As such, the edge device and all up-line HDC devices operate under the backup traditional protection coordination described in Section II, Subsection A.

The backup scheme reduces the number of protective devices within the HDC scheme, which can allow traditional coordination with out-of-network devices without extending device operating times outside of desired ranges. An example is provided in Fig. 6.

#### 2) Fault Within the HDC System During Power Import

For a fault within the HDC system being fed from the external network, the edge device receives one external block if the event is beyond its zone. It receives no external blocks if the fault event is within its zone. This logic, similar to the source device logic, allows high-speed operation for a fault anywhere within the HDC system. An example is provided in Fig. 7.

## IV. ADDITIONAL FUNCTIONALITY

### A. Protection During Communications Failure

Each device receives constant updates on the status of neighboring devices. If communications are lost with one or more neighboring units, then the device enters a loss-of-communications mode. While in this mode, enhanced coordination behavior is disabled, but the device maintains its configured traditional protection coordination behavior as a recloser, sectionalizer, or switch, with standard coordination times.

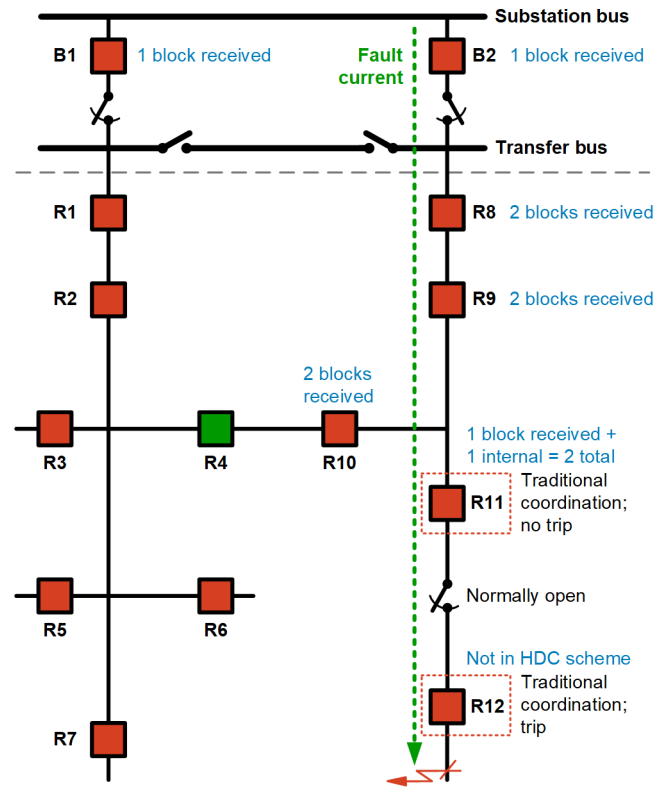

Fig. 6. Coordination for out-of-network faults.

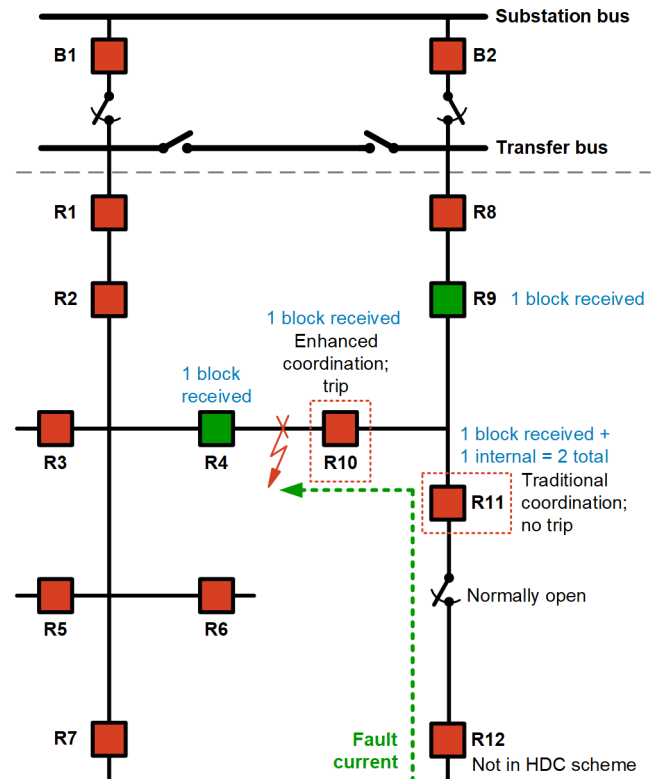

Fig. 7. Coordination for in-network faults with out-of-network sources.

However, the device still transmits enhanced coordination communications to neighboring devices to prevent the entire network from collapsing. Therefore, the unit still publishes block signals for neighboring devices even if the unit itself does not act based on blocks. An example is shown in Fig. 8. All devices not shown as having HDC disabled still operate using the HDC fast elements.

### B. Trip Failure

A simple breaker failure scheme can be built into the system to allow up-line protection to operate if an interrupting device fails to clear the fault (bottle failure or failure to operate). If a trip failure is detected, the protective device stops transmitting its block signal. This allows the next up-line device to operate on its high-speed overcurrent element immediately after the down-line device reports a trip failure. This scheme maintains operation speed and coordination while minimizing total fault duration and dropped lines. An example is shown in Fig. 9.

### C. Communications Testing

Network availability and speed are key to the HDC fast blocking scheme. Scheme provisioning and commissioning needed to be as simple as possible without compromising functionality. During commissioning, the deployment team had to verify the communications paths to and from each adjacent device on the network and between the PLC and recloser control within the cabinet. In addition, the team had to confirm GOOSE message publication and subscription mapping, and that the scheme could operate in the specified time.

Consideration for all the above led to the development and implementation of logic within the PLC template that provides local annunciation of the network communications health. This includes a receipt of subscribed data, as well as supervisory control and data acquisition data and engineering access communications status. The logic also records changes in communications to a sequence of events log. Finally, the logic provides a test (which can be initiated from a pushbutton on the control) verifying GOOSE message publishing to the appropriate devices and that the block signal transfer time is well within the margin to meet the 3-cycle operation time.

## V. REAL-WORLD EVENT ANALYSIS

The following analysis is from a live system operation of the HDC scheme on the Alabama Power distribution network.

### A. System Before Modifications

Initially, four feeders were selected to have the recloser control density increased and this HDC scheme applied. Feeder 1, the focus for this particular event (shown as B1 in Fig. 9), served 1,707 utility customers and had protection split between two protective devices located at Reclosers R1 and R2.

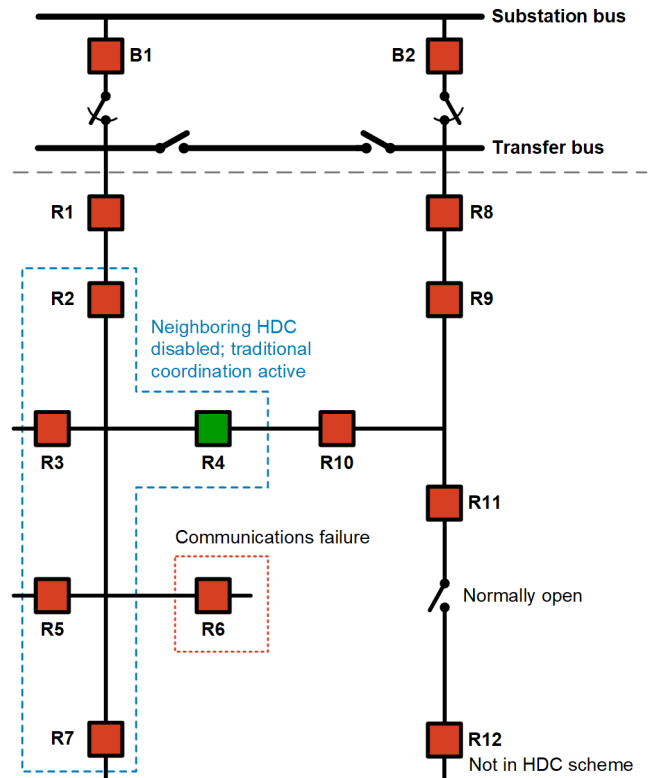

Fig. 8. Partial communications failure scheme.

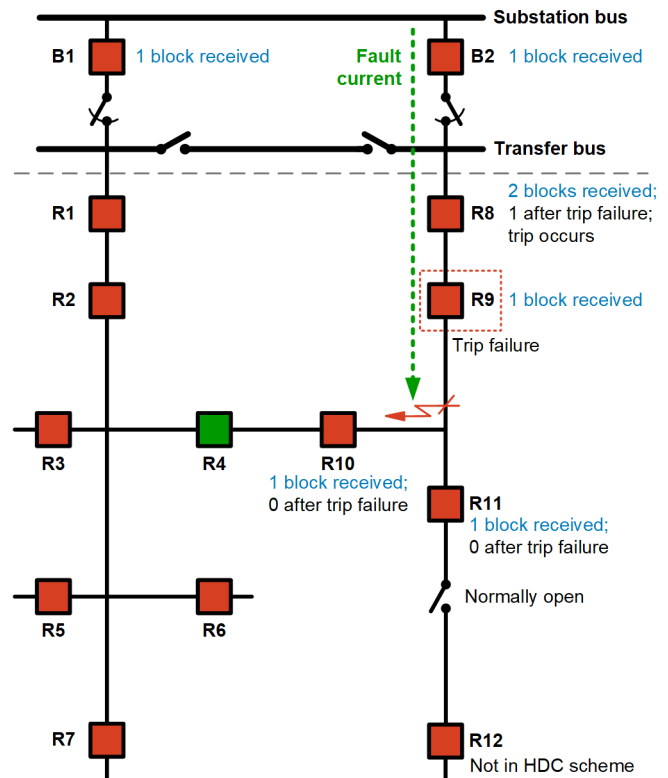

Fig. 9. Trip failure scheme.

Some months after the system was updated with additional reclosers, a storm caused a tree to fall on the line beyond Recloser R2. For comparison purposes with the HDC scheme, this fault is also considered in the original configuration to determine the impact to utility customers, as shown in Fig. 10.

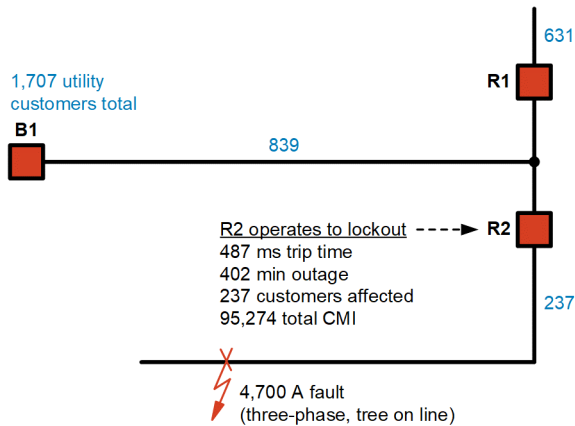

Fig. 10. Initial system configuration. Each line segment is labeled with utility customer count.

The fallen tree caused a 4,700 A three-phase fault on the line. In the original configuration, Recloser R2 would have tripped in 487 milliseconds based on the standard time-overcurrent curve settings applied. After the device locked out, 237 utility customers would have been affected by the outage.

The fallen tree was cleared by Alabama Power personnel, and the line returned to service in 402 minutes, which in the initial configuration would have resulted in a total Customer Minutes of Interruption (CMI) of 95,274 for this event.

### B. System After Modifications

Alabama Power wanted to reduce the utility customer count to under 400 for each line segment. They added recloser controls to line segments to strategically reduce the utility customer count at points where it made sense to physically locate reclosers. The resulting zones and utility customer counts are shown in Fig. 11.

The three-phase fault occurred on a line segment with two utility customers. The devices at Breaker B1 and Reclosers R3, R4, R6, R8, R9, R2, R13, and R14 all saw the fault current and asserted the HDC blocking signal. The device at Breaker B1 received one block from the recloser control at Recloser R3 and was also self-blocked due to being an edge device, so it blocked the HDC fast trip signal. The devices at Reclosers R3, R4, R6, R8, R9, R2, and R13 all received one block signal from up-line as well as one from down-line, so they also all blocked the HDC fast trip.

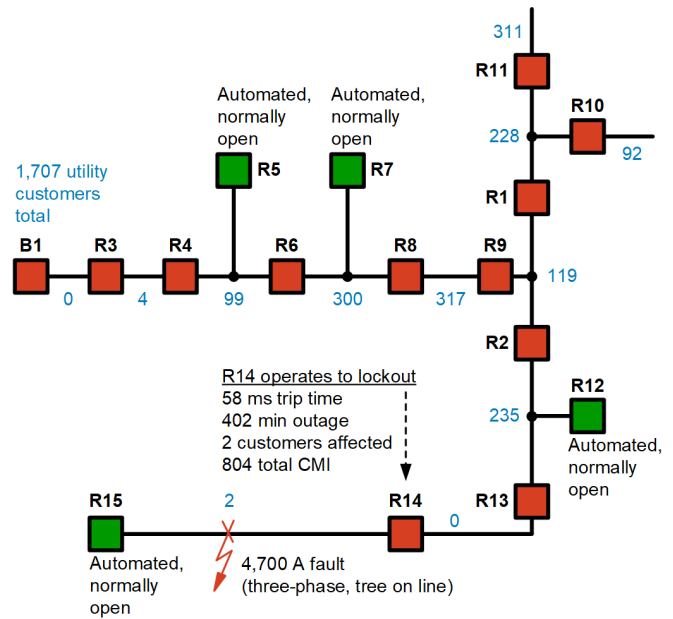

Fig. 11. System after addition of fiber-optic communications, more recloser controls, and the HDC scheme.

The device at Recloser R14 received a block signal from the up-line device at Recloser R13 but did not receive a block signal from the device at Recloser R15, because no fault current was flowing through the Recloser R15 device. After a short communications and coordination time delay of 3 cycles, the Recloser R14 device tripped, clearing the initial fault in 6 cycles. Reclosing was enabled, and the device at Recloser R14 eventually tripped to lockout.

### C. Event Data From Recloser R3 Device

Although the HDC scheme was tested in a lab setting, it was also important to confirm system performance and timing for real-world conditions. The data shown are from the device at Recloser R3, which is the furthest up-line recloser control. The Recloser R3 device should see the fault current, issue a block signal, and receive a block signal from the local PLC after blocks from both neighbors are received. The device at Recloser R3 should then block the HDC fast trip as long as the block signal is received, and eventually allow the traditional backup overcurrent element to operate if the fault failed to be cleared by down-line devices.

When the fault occurred, the traditional overcurrent minimum pickup (51\_PICKUP) asserted. This signal is used to send block signals (BLOCKSEND) to adjacent devices. The HDC fast trip element (HDC\_PICKUP), with a higher set point than 51\_PICKUP, picked up 4 milliseconds later due to the recloser control signal filtering algorithm. The two adjacent devices at Breaker B1 and Recloser R4 both sent blocking

signals, combined into the BLOCKREC signal, which was received 30 milliseconds after fault inception. While BLOCKREC was asserted, the HDC fast trip (HDC\_TRIP) was disabled and no trip occurred, allowing the device to continue to serve other utility customers outside the faulted zone. Fig. 12 shows the event data.

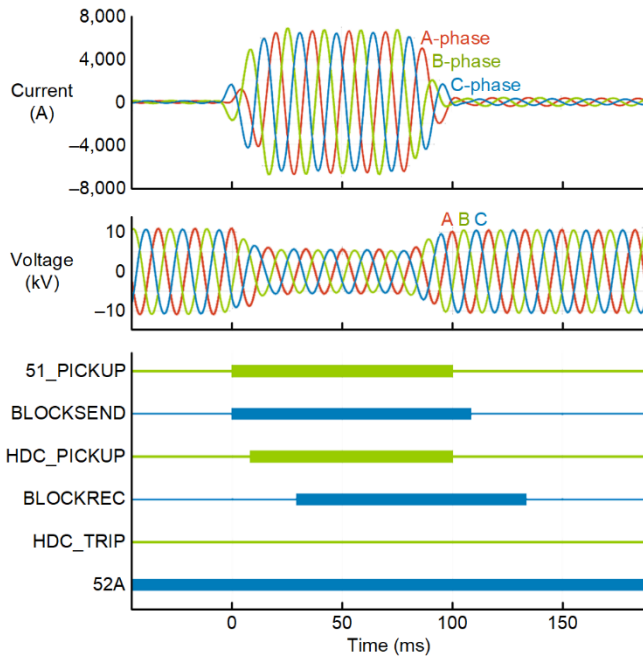

Fig. 12. Recloser R3 device event data.

#### D. Event Data From Recloser R14 Device

The device at Recloser R14 was the closest device to the fault and correctly tripped for this fault. This protective device was closer to the fault than the Recloser R3 device, which is evident in the Recloser R14 device event data, shown in Fig. 13: the voltage is almost completely depressed.

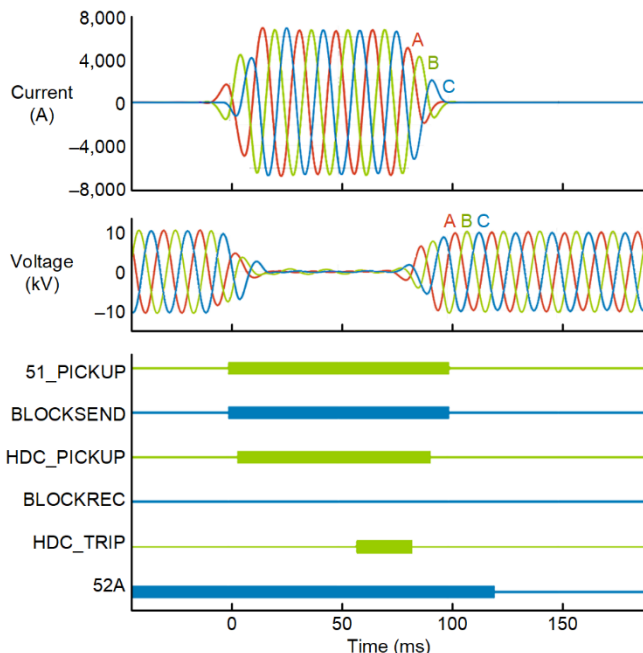

Fig. 13. Recloser R14 device event data.

As in the Recloser R3 device event data, 51\_PICKUP asserted on fault inception, which caused the protective device to send blocking signals to the adjacent devices at Reclosers R13 and R15. The HDC fast trip element picked up and began timing to trip. The device at Recloser R15 did not receive a blocking signal, so the combined blocking signal BLOCKREC did not assert. The HDC fast trip element timed out 58 milliseconds later and asserted the HDC\_TRIP signal. The protective device tripped and cleared the fault.

#### E. System Comparison

The fault that occurred after the system was modified to add recloser controls and implement the HDC scheme allows for a comparison between the improved system and an estimation of how the old system might have operated.

For the actual fault event on the modified system, two utility customers were left in an outage for 402 minutes before the line could be returned to service, resulting in a CMI of 804. Compared to the original system configuration, this new configuration and HDC scheme prevented 235 utility customers from experiencing an outage on the line segment between Reclosers R2 and R14. This reduced the CMI by 99.2 percent, to 804 from an original estimate of 95,274.

Although this is an extreme case, reducing the number of utility customers affected by an outage directly improves the System Average Interruption Duration Index (SAIDI) [1]. Fewer utility customers experience interruptions and reclosing cycles, so the System Average Interruption Frequency Index (SAIFI) is also improved.

## VI. CONCLUSION

Applying an HDC protection scheme for distribution purposes allows for an increased density of protective devices, increasing reliability metrics without impacting protection operating times and without adding undue burden to system design or deployment.

While the use of IEC 61850 GOOSE-based trip-blocking is not a novel concept, it is usually implemented with a very specific system architecture in mind. The use of it for large-scale distribution network protection with an emphasis on ease of deployment and scalability is new. The inherent directionality of this scheme, using a combination of blocking signals and fault current detection, provides an innovative and robust solution: a scheme that adapts instantly to any feeder configuration with no control settings changes or modifications to the communications path required. This case study illustrates the concept of a blocking scheme for distribution purposes and lists considerations for developing such a system.

The Alabama Power case is a good example of the improvements in reliability metrics that can be achieved when implementing high-density coordination schemes. While the specific requirements for implementing such a system are not feasible for all utilities or locations, the general concepts are still applicable and can inspire development of alternative communications-based protection schemes.

## VII. REFERENCE

- [1] IEEE Standard 1366-2012, IEEE Guide for Electric Power Distribution Reliability Indices.

## VIII. BIOGRAPHIES

**Robert M. Cheney** began working at Alabama Power Company in 1978 as a field engineer. He is currently serving as a Principal Engineer in the Distribution Engineering Support department. Part of his duties in this role are to initiate and implement new operating practices made possible by using modern electronic controls now available on switches and reclosers. Robert graduated from Auburn University with a BS in electrical engineering and later received his MS degree in electrical engineering from the University of Alabama at Birmingham.

**John T. Thorne** has twenty years of experience at Alabama Power Company, serving in various distribution engineering positions. He has experience in construction, protection, and reliability at the company. He presently holds the position of Power Delivery Test Lab Team Leader. He received his BS in electrical engineering from Auburn University in 2004.

**Robert Van Singel** received his BSEE and MSEE from Michigan Technological University in 2008 and 2010, respectively. He joined Schweitzer Engineering Laboratories, Inc. (SEL) in 2009 as an intern. After completing his MSEE, Robert joined SEL Engineering Services, Inc. as a protection engineer. In 2011, he changed focus and currently works as an automation engineer.

**Andrew Hanson** received his BSEE and BS in physics from Clemson University in 2015. Andrew joined Schweitzer Engineering Laboratories, Inc. (SEL), where he serves as a project engineer for SEL Engineering Services, Inc. in Atlanta, Georgia. His work focuses on designing, developing, and deploying automation schemes for distribution networks.

**Chris Anderson** graduated from ITT Technical Institute in 1999 with an AAS in electrical and electronics technology. He joined Schweitzer Engineering Laboratories, Inc. (SEL) in July of 1999, as a firmware test technician in research and development, later advancing to associate development engineer, associate product engineer for transmission, and product engineer for phasor measurement technology. Chris is currently a senior application engineer with a focus in automation, communications, and security. Chris is a Certified Information Systems Security Professional (CISSP) and a member of the IEEE.

**Joshua Hughes** graduated from Tennessee Technological University in 2004 with a BSEE focused on digital signals. He worked as a System Engineer at Tennessee Valley Authority nuclear substations providing commissioning services, root cause analysis, and system data trending to predict equipment failures. In 2009, Joshua joined Schweitzer Engineering Laboratories, Inc. (SEL), where he served SEL Engineering Services, Inc. as a project engineer and a senior application engineer. His work included providing application and product support and technical training for protective relay users. In 2020, Joshua joined Patterson Power Engineers, LLC as a protection consultant, providing system studies, testing, and root cause analysis. Joshua is a member of the IEEE and is a registered professional engineer in the state of Tennessee.