

---

---

# **Application of Phase and Ground Distance Relays to Three Terminal Lines**

**G. E. Alexander  
J. G. Andrichak  
General Electric Company  
Protection and Control  
Malvern, PA**

---

---

*Presented to*  
**Twenty Second Annual  
Western Protective Relay Conference  
Spokane, Washington  
October 25, 1995**

---

---

# **APPLICATION OF PHASE AND GROUND DISTANCE RELAYS TO THREE TERMINAL LINES**

G. E. Alexander  
J. G. Andrichak  
GE Protection & Control  
Malvern, PA

## **INTRODUCTION**

The ideal performance of a transmission line relaying system for either a two terminal or a three terminal line may be defined in broad terms as follows:

Trip all terminals simultaneously for any internal fault at any location on the line with any expected distribution of current contributions.

Do not trip any terminal(s) for any external fault at any location on the system with any expected distribution of current contributions.

The distance relay settings required to achieve these goals depend upon the configuration of the power system and the type of protective scheme employed. In order to provide simultaneous tripping of all three terminals, it is desirable that the over reaching distance functions be set large enough that relays at all three terminals will respond to all internal faults with all line breakers closed, regardless of a possible outage of an adjacent power system component. At the same time, the reach of the distance functions must not allow operation for the maximum load flow, or load swing conditions.

The application of distance relays to the protection of three terminal lines is more complex than the application to two terminal lines due to the infinite variety of tap locations, line impedances, source impedances, system loading requirements, and system operating conditions. One concept that is important in determining the settings of the distance functions is that of the apparent impedance seen by a distance relay for various system and fault conditions.

## APPARENT IMPEDANCE

The impedance "seen" by a distance relay is not always the actual line impedance from a relay terminal to the point of fault. This is because the relay measures impedance based on the voltage drop between its location and the fault and the line current at its location. Thus, the impedance "seen" by the relay will depend upon the current contributions from the other terminals. Consider the system shown in Figure 1. Due to the infeed current at terminal B, the distance relay at terminal A will see an apparent impedance of 3 ohms, which is greater than the actual impedance to the fault.

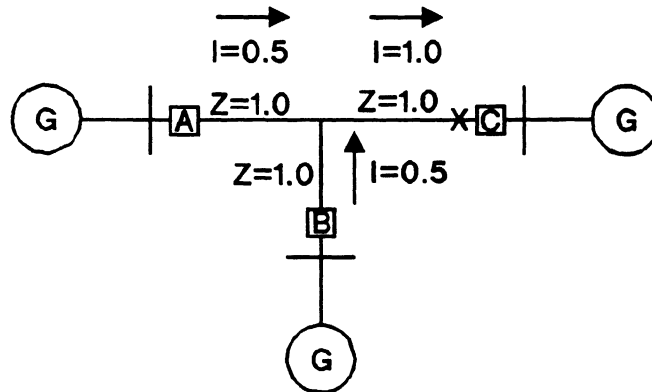

ACTUAL IMPEDANCE FROM A TO FAULT = 2.0 OHMS

$$\text{APPARENT IMPEDANCE} = \frac{E}{I} = \frac{(1 \times 0.5) + (1 \times 1)}{0.5} = 3.0 \text{ OHMS}$$

**Figure 1 - Current Infeed**

The system shown in Figure 2 has an outfeed current at terminal B rather than an infeed current. In this case, the apparent impedance seen by the relay at terminal A for a fault at terminal C is 1.5 ohms, which is less than the actual impedance to the fault. An additional problem is also introduced by the current outfeed at terminal B; since the current flows out of the line at B, a forward looking distance relay will not see this internal fault, in fact, if there is a blocking unit at B, it may "see" the internal fault as an external fault and thus prevent tripping.

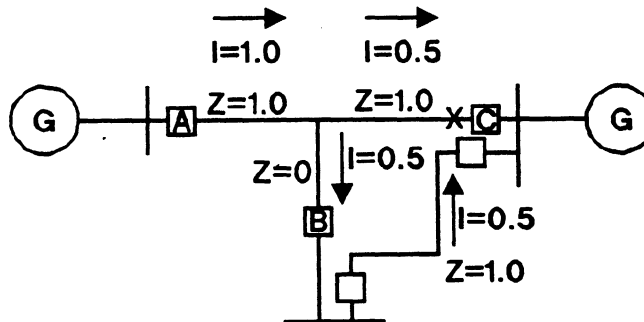

ACTUAL IMPEDANCE FROM A TO FAULT = 2.0 OHMS

$$\text{APPARENT IMPEDANCE} = \frac{E}{I} = \frac{(1 \times 1) + (1 \times 0.5)}{1.0} = 1.5 \text{ OHMS}$$

**Figure 2 - Current Outfeed**

From these simple examples it can be seen that the apparent impedance measured by the distance relay will be affected by the current contributions at the various line terminals. The setting of the direct tripping Zone 1 functions and the permissive overreaching functions must be calculated to provide the desired performance.

### **HIGH SPEED TRIPPING MODES**

It is desirable that any fault on a transmission line be cleared in high speed from all terminals. This is often referred to as "simultaneous" clearing. In actual fact, very few - if any - faults will be cleared simultaneously due to differences in relay operating times, channel delays, and breaker operating times. Near simultaneous high speed tripping can be initiated in several ways. The first is via the use of direct tripping Zone 1 functions. These functions will operate independent of the pilot scheme to provide high speed clearing. However, the Zone 1 functions at all terminals will not operate for all faults. For those faults that are not within the reach of the Zone 1 functions, the pilot tripping logic will provide a means to initiate high speed clearing of the fault. In order for the pilot scheme to initiate high speed clearing, all internal faults must be seen by the overreaching distance functions at all terminals of the line.

When the Blocking or Hybrid pilot schemes are used, it is also possible to have "sequential" high speed tripping of the circuit breakers at all terminals. When the line is protected with a Blocking scheme, high speed pilot tripping may be initiated at any terminal where the overreaching functions operate, provided that no blocking functions operate at any terminal. Therefore, even if the overreaching function at only one terminal sees the fault, the relay at that terminal can operate. Once its associated circuit breaker has opened, any infeed from that terminal is eliminated and the overreaching functions at the other two terminal will see the fault and issue a pilot trip. Thus, while all three breakers do not operate simultaneously, there is no intentional time delay added to clear the fault such as that needed for a time delayed backup trip. The Hybrid scheme can operate in a similar manner to the Blocking scheme; however, with the Weak infeed trip option the Hybrid scheme can initiate high speed tripping at all terminals if an overreaching function from at least one terminal sees the fault. Thus, with the Blocking or Hybrid scheme, the high speed tripping will be near simultaneous even though the fault could not be seen from all terminals.

### **PILOT RELAYING SCHEME LOGICS**

There is a variety of pilot relaying schemes in use on both two and three terminal lines. Some of these schemes may have application limitations on some three terminal line configurations. The type of pilot relay scheme will also affect the settings required for a three terminal line application. The following schemes will be considered:

- Direct Underreaching Transfer Trip
- Permissive Underreaching Transfer Trip
- Permissive Overreaching Transfer Trip
- Directional Comparison Blocking
- Hybrid

## Direct Underreaching Transfer Trip

In the Direct Underreaching Transfer Trip (DUTT) scheme the Zone 1 functions key a direct transfer trip to the remote terminals as well as tripping the local breaker. The DUTT scheme will provide near simultaneous tripping at all terminals. However, in order for this scheme to clear the fault, the fault must be seen by the Zone 1 functions from at least one terminal. Depending upon the settings of the Zone 1 functions required for the line configuration, this may not be possible.

Consider the system of Figure 3. Because the impedance between terminals A and B is small compared to the impedance from C to A or B, if a typical Zone 1 reach of 85 - 90 % is assumed, there will be a portion of the transmission line that is not covered by a Zone 1 function at any terminal. For this condition, the DUTT scheme will not provide adequate protection for the line.

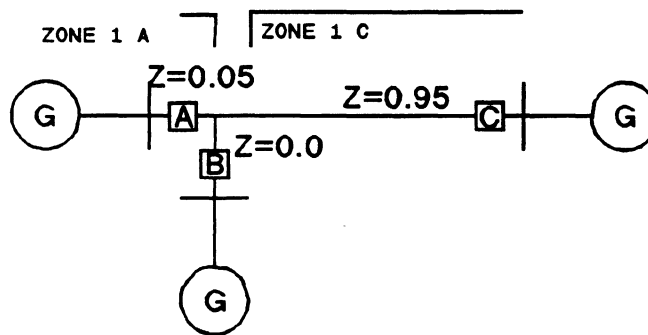

Figure 3

Consider the system of Figure 4. The Zone 1 distance functions at terminals A and C may typically be set to 0.85 ohm. Thus, when the breaker at terminal B is open, the DUTT scheme will not trip for fault locations near the tap because the reach of the Zone 1 functions at A and C do not overlap to provide full coverage of the line.

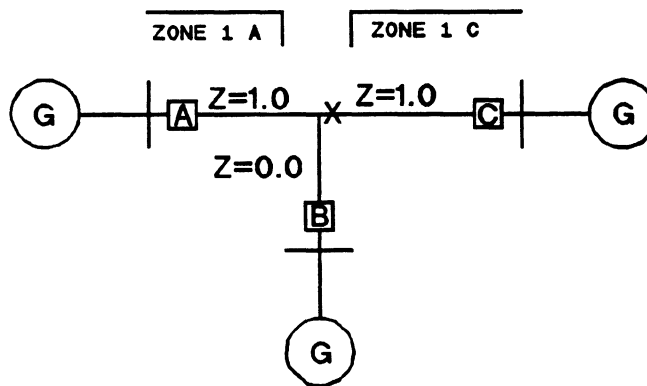

Figure 4

## Permissive Underreaching Transfer Trip

In the Permissive Underreaching Transfer Trip (PUTT) scheme the Zone 1 functions key a permissive trip to the remote terminals as well as tripping the local breaker. If the Zone 1 does not operate at a terminal, a trip will be issued if a permissive signal is received and an

overreaching distance function has operated. In order for this scheme to clear the fault in high speed, the fault must be seen by the Zone 1 function from at least one terminal and the overreaching functions from the other terminals. Since this scheme requires a Zone 1 function to respond to the fault, it has similar limitations to the Direct Underreaching Transfer Trip scheme. In PUTT applications on two terminal lines, it is a typical practice to use a circuit breaker 'b' switch to send a permissive signal to the remote terminal when a breaker is open. This allows high speed clearing for faults any where on the line via the overreaching units. In three terminal PUTT applications 'b' switch keying can not be employed as it could result in over-tripping for external faults.

### **Permissive Overreaching Transfer Trip**

In the Permissive Overreaching Transfer Trip (POTT) scheme the permissive channel is keyed by the operation of the overreaching distance functions. Tripping is initiated only if the local overreaching distance functions detect a fault, and a permissive trip signal is received from both remote terminals. Thus, the reach of the permissive tripping functions must be set to see all internal faults for all infeed conditions. This is a very secure scheme since all terminals must see the fault before tripping can be initiated at any terminal. In some systems, however, due to weak infeed at one or more terminals, or because the reach is limited by the maximum load flow over the line, or because there is current outfeed at one terminal as shown in Figure 2, it may not be possible to set the overreaching functions at one or more terminals to see all faults on the protected line. In this case, the permissive overreaching scheme will not provide high speed clearing of the fault at any terminal and an alternate scheme must be considered.

### **Directional Comparison Blocking**

Typically, the Directional Comparison Blocking scheme will employ an AM ON-OFF type of channel that is keyed for external faults. Therefore this scheme requires the addition of blocking functions at all terminals. Tripping is initiated if a local overreaching distance function has operated, and a blocking channel is not being received. If a blocking function operates at any terminal, pilot tripping will be prevented at all terminals. In order for this scheme to initiate high speed tripping at all terminals, the overreaching distance functions must be set to see all internal faults for all infeed conditions. However, high speed sequential fault clearing may be initiated if at least one overreaching distance function sees the fault and no blocking units operate and if the remaining terminals can see the fault after the remote breaker opens. This feature enhances the dependability of the Directional Comparison Blocking scheme. If current outfeed exists as shown in Figure 2, the blocking unit at B must be set so that it does not start the blocking carrier for any internal faults and thereby prevent tripping.

### **Hybrid**

The Hybrid scheme is a balance of the security of the Permissive Overreaching scheme and the dependability of the Directional Comparison Blocking scheme. The Hybrid scheme requires both permissive overreaching and blocking functions. It is essentially a Permissive Overreaching Transfer Trip scheme with blocking functions, channel repeat (echo) logic and a weak infeed trip logic option. As in a POTT scheme, tripping is initiated when a local overreaching function has operated and a permissive signal is received from both of the remote terminals; as in the

Directional Comparison Blocking scheme, the operation of a blocking function at any terminal will prevent pilot tripping at all terminals. Therefore, if current outfeed exists as shown in Figure 2, the blocking unit at B must be set so that it does not operate for any internal fault.

In the Hybrid scheme simultaneous high speed tripping may be initiated at all terminals even if the overreaching functions operate at only one terminal. This is accomplished via the channel repeat and weak infeed tripping logic. The channel repeat logic sends a permissive signal to the two remote terminals if a permissive signal is received and no local blocking function has operated. The weak infeed tripping logic can be used to initiate tripping if a permissive signal is received from both remote terminals and no local blocking functions have operated and there is some local fault indication.

## SETTING CONSIDERATIONS

### Zone 1 Distance Functions

Zone 1 distance functions are required for the DUTT and PUTT schemes and may be used in the POTT, Blocking, and Hybrid schemes to improve performance. Regardless of the relay scheme in which they are employed, the Zone 1 distance functions must be set so that they do not overreach the nearest remote line terminal. Typical settings would be 85 - 90 percent of the positive sequence line impedance to the nearest terminal. In those systems subject to current infeed, the impedance is based on the actual line impedances, rather than the larger apparent impedance due to current infeed because the breaker at the terminal contributing the infeed may be open. If the system can experience current outfeed, however, then the reach of the Zone 1 functions must be reduced to prevent misoperation on the apparent impedance, which will be less than the actual line impedance.

### Over Reaching Distance Functions

In the Permissive Overreaching Transfer Trip scheme the overreaching distance functions must be set to see beyond the farther terminal for all expected current distributions; if the overreaching functions at any terminal do not operate, none of the relays will be permitted to trip. In the Directional Comparison Blocking and Hybrid schemes, it is not required that the overreaching functions operate at all terminals for the fault to be cleared. It is possible to use shorter reach settings if high speed sequential tripping of the line is acceptable. A typical setting for the overreaching functions would be 125 - 150 percent of the larger apparent impedance to the remote terminals. It is also a requirement that the overreaching functions should not operate under the maximum load conditions on the line. On some systems it may not be possible to set the distance functions to see all faults with margin and to also meet the maximum load requirements.

Figure 5 shows an RX diagram view of several popular means available to reduce the susceptibility of a mho distance function to operation on load impedance. In Figure 5A the reach of the mho function has been reduced from the desired setting to meet the margin requirements between the characteristic and the maximum load impedance point. If only a circular mho function is available in the relay, this method must be employed. Figure 5B shows how a

lenticular characteristic may be used to reduce the susceptibility of a mho distance function to operation on load impedance without reducing the reach setting of the function. Many mho distance relays are designed with the capability of using either a circular or a lenticular characteristic. It is also possible to add other characteristics to reduce the coverage of a circular mho. One approach that adds 'blinders' in addition to the mho distance characteristic is shown in Figure 5C. In this approach, the impedance must plot within both the mho and the blinder characteristics to produce a trip output. If out-of-step blocking is employed on the line, allowance must be made for the out-of-step characteristic outside the over reaching permissive function. Figure 5D indicates how the addition of an Out-of-Step characteristic might reduce the maximum setting of the mho tripping function.

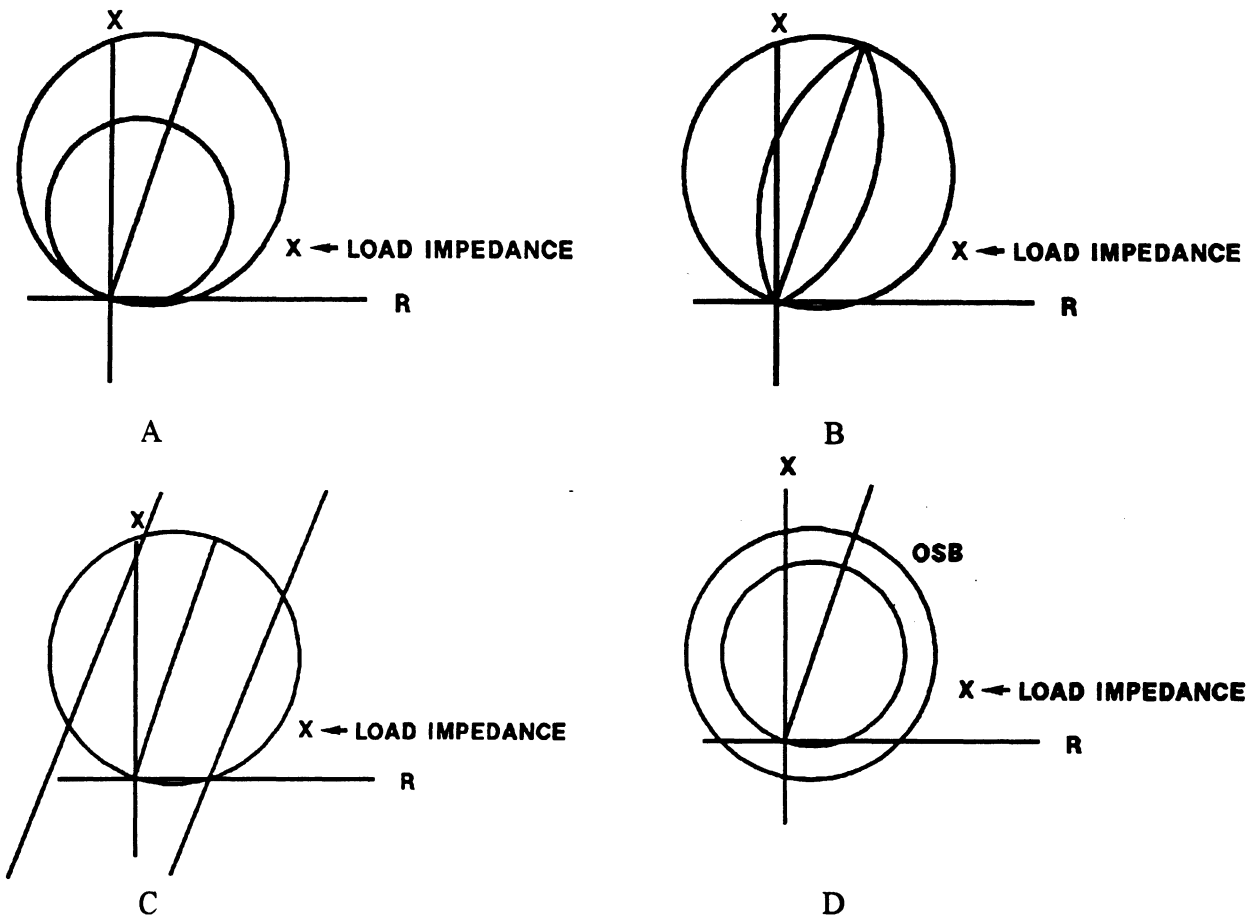

Figure 5

### *Phase Distance Functions*

The calculation of the apparent impedance that results from the infeed at the tap requires knowledge of the maximum current contributions from other terminals, and typically requires a fault study that takes into account possible outages of lines, generation, or both. For the relay at terminal A (Figure 6), the apparent impedance must be calculated for faults in front of both terminal B and C. Two methods may be used to calculate the apparent impedance seen by the

phase distance functions. The first method involves only the current and voltage applied to the relay. The apparent impedance seen by a phase to phase distance function may be calculated from the relationship:

$$Z_{\phi\phi} = \frac{V_{\phi\phi}}{I_{\phi\phi}} \quad (1)$$

The apparent impedance measured by a relay at terminal A (Figure 6) for faults at the remote terminals may also be calculated using the fault currents:

$$Z_{AB} = Z_{AT} + Z_{BT} \times \frac{I_{AT} + I_{CT}}{I_{AT}} \quad (2)$$

$$Z_{AC} = Z_{AT} + Z_{CT} \times \frac{I_{AT} + I_{BT}}{I_{AT}} \quad (3)$$

Where:

- $Z_{AB}$  is the impedance seen by the relay at A for a fault at B
- $Z_{AC}$  is the impedance seen by the relay at A for a fault at C
- $Z_{AT}$  is the positive sequence impedance from A to the tap location.
- $Z_{BT}$  is the positive sequence impedance from B to the tap location.
- $Z_{CT}$  is the positive sequence impedance from C to the tap location.
- $I_{AT}$  is the current contribution from terminal A.
- $I_{BT}$  is the current contribution from terminal B.
- $I_{CT}$  is the current contribution from terminal C.

Similar relationships, with the appropriate subscripts, apply for the apparent impedances seen by the relays at terminals B and C for remote end faults. The currents used to calculate the apparent impedance for the phase functions may be taken from a phase to phase fault or a three phase fault.

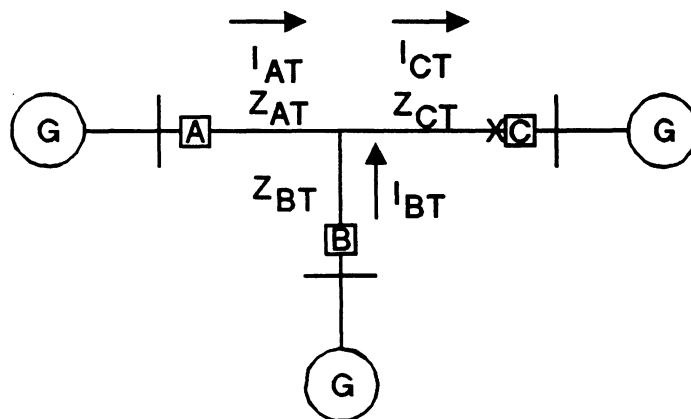

Figure 6 - Apparent Impedance from Terminal A

The reach setting of the distance functions is based on several requirements. For Permissive Overreaching schemes, the distance functions at all terminals must respond to all internal faults.

The minimum recommended reach setting is typically 125 percent of the maximum apparent impedance that the relay can see. In the Blocking scheme, two options are available. First, if near simultaneous high speed clearing is required, the reaches must be set as in the Permissive Overreaching scheme. If, on the other hand, high speed sequential tripping is acceptable, shorter reach settings may be employed. In this case, it is required that at least one relay responds to every internal fault. Thus the required reaches can be smaller and the setting procedure may be simplified. In the Hybrid scheme, the required reach settings are similar to those in a Blocking scheme. However, if weak infeed tripping logic is employed in the relay system, simultaneous high speed tripping can be initiated at all terminals even when the distance functions do not operate at all terminals.

An additional requirement for the phase distance functions is that they must not operate for any expected load conditions. Therefore, after the desired reaches have been determined, they must be compared with the maximum expected load conditions to insure adequate margin. The required margins are part of the standard relay setting calculations for both two and three terminal line applications. If the maximum load flow limits the reach settings of the distance functions, it may not be possible to use the Permissive Overreaching scheme as tripping may be prevented for some internal faults.

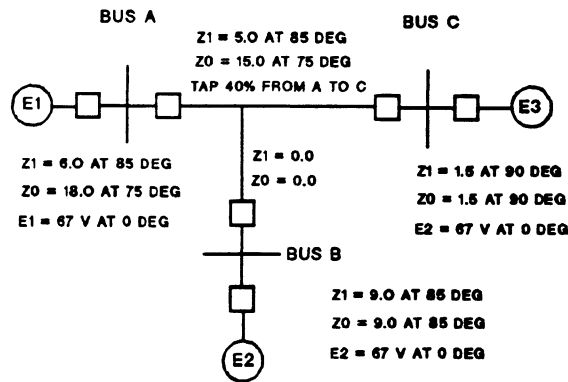

Figure 7

Consider the system of Figure 7 with a BC fault on the line side of the circuit breaker at bus C. A phase BC relay at bus A will see the following current and voltage:

$$V_{BC} = 65.1 \text{ at } -90 \text{ degrees}$$

$$I_{BC} = 8.524 \text{ at } -175 \text{ degrees}$$

The apparent impedance presented to the BC distance relay is:

$$Z_{\phi\phi} = \frac{65.1 \angle -90}{8.524 \angle -175} = 7.64 \text{ ohms at } 85 \text{ degrees}$$

The actual impedance of the line is only 5 ohms. The apparent impedance for this fault could also be calculated by using the current at A and the current at B. The phase BC current at B is 7.55 at -175 degrees. The apparent impedance is therefore:

$$Z = 2 + 3 \times \frac{8.524 + 7.55}{8.524} = 7.66$$

For this system, the maximum apparent impedance seen by the relay at A for an internal fault is for a fault at B. A typical reach setting for this function would be 125 to 150% of the calculated apparent impedance, or 9.5 - 11.5 ohms.

It is possible to simplify the required calculations in a Blocking or Hybrid scheme, if high speed sequential tripping is acceptable, or if the weak infeed trip option is used. This can be done by assuming that the infeed current is equal to the relay current. Using this "quick" calculation, the overreaching functions at terminal A would be set to the larger of:

$$OR_{AC} = 1.25 \cdot (Z_{AT} + 2 \cdot Z_{CT}) \quad (4)$$

$$OR_{AB} = 1.25 \cdot (Z_{AT} + 2 \cdot Z_{BT}) \quad (5)$$

These settings insure that at least one of the remote overreaching functions will operate for all internal faults, with a margin of 25 percent. If the reaches determined by equations 4 and 5 meet the load flow requirements, no further calculations are needed.

### ***Ground Distance Functions***

The apparent impedance calculation for the ground distance is similar to that used for the phase distance functions except that the currents are based on single line to ground faults. The apparent impedance seen by a typical phase A ground distance relay can be calculated from the following relationship:

$$Z_{AG} = \frac{V_{AG}}{IA1 + IA2 + K0 \cdot I0} \quad (6)$$

Where:

$V_{AG}$  is the phase to ground voltage at the relay location.

$IA1$  is the positive sequence component of the relay current.

$IA2$  is the negative sequence component of the relay current.

$I0$  is the zero sequence component of the relay current.

$K0$  is a phasor quantity typically set based on the ratio of  $Z0/Z1$  for the line.

In order to use equation 6 to calculate the apparent impedance seen by a ground distance relay on a three terminal line, the  $K0$  setting used in the relay must be known. In most ground distance relays, the  $K0$  factor is used to set the zero sequence impedance reach of the relay independently from the positive sequence impedance. In a two terminal line application, this setting is based on the actual zero and positive sequence line impedances; for three terminal lines the apparent impedances are used to adjust for the effects of infeed currents. Thus, for the ground distance

relays the required relay settings can not be obtained directly from this calculated apparent impedance. By using the infeed current from the other terminal the ground relay functions settings can be optimized for both the positive/negative sequence reach and the zero sequence current compensation.

Consider an AG fault on the line side of the circuit breaker at bus C in Figure 7.

	<u>Terminal A</u>	<u>Terminal B</u>
VAG	40.51 $\angle -0.8^\circ$	31.69 $\angle -1.3^\circ$
IA1	1.580 $\angle -84.9^\circ$	1.405 $\angle -84.9^\circ$
IA2	1.580 $\angle -84.9^\circ$	1.405 $\angle -84.9^\circ$
I0	0.4192 $\angle -70.9^\circ$	1.118 $\angle -80.9^\circ$

The apparent positive sequence impedance seen by the AG ground distance relay at A is:

$$\text{Apparent } Z1 = 2 + 3 \times \frac{1.580 + 1.405}{1.580} = 7.67 \angle 85^\circ$$

As might be expected, this is the same value of positive sequence impedance seen by the phase distance functions for a phase to phase fault at the same location. The ratio of apparent positive sequence impedance to the actual positive sequence impedance for this fault is 7.67/5, or 1.534. A typical positive sequence reach setting for this function would be 125 to 150% of the calculated apparent impedance.

The apparent zero sequence impedance seen by the AG ground relay at A is:

$$\text{Apparent } Z0 = 6 \angle 75^\circ + 9 \angle 75^\circ \times \frac{0.419 \angle -70.9^\circ + 1.118 \angle -70.9^\circ}{0.419 \angle -70.9^\circ}$$

$$\text{Apparent } Z0 = 38.87 \angle 68.8^\circ$$

The ratio of apparent zero sequence impedance to the actual zero sequence impedance for this fault is 38.87/15, or 2.591. Due to the system configuration, the zero sequence impedance is magnified by a larger factor than the positive sequence impedance. For a relay using the K0 factor of Equation 6, the apparent zero and positive sequence impedances should be used to calculate K0 rather than the actual line impedances. Thus the K0 factor setting should be:

$$K0 = \frac{\text{App. } Z0}{\text{App. } Z1} \quad (7)$$

$$K0 = 5.1 \angle -16.2^\circ$$

#### *Possible Loss of Ground Distance Function Directionality on External LLG Faults*

The previous discussion concerned the need to set the ground distance relay reach large enough to insure that the relay will respond to all faults on the protected line. It is well known that the

long reaches that may be required to insure distance relay operation on three terminal lines increase the susceptibility of the relay to load related problems. However, the long reaches may introduce other problems as well.

Consider the system of Figure 8. In this system, the impedance between Bus B and Bus C is small compared to the impedance from the tap point to Bus A. This results in large reaches for the permissive units at Busses B and C. The currents and voltages for the relay at Bus C for a BCG fault on the bus at terminal C are shown in the table.

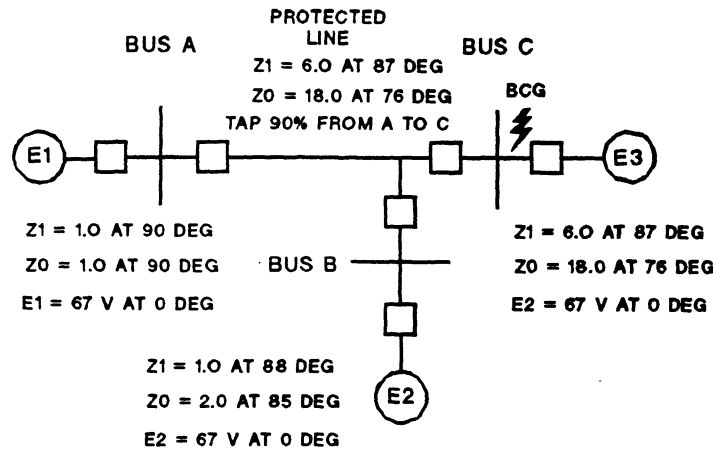

Figure 8

### FAULT CALCULATIONS

Sequence	Phase
$I_1 = 26.6$ A $\angle 93^\circ$	$I_A = 0.3$ A $\angle -96^\circ$
$I_2 = 19.1$ A $\angle -89^\circ$	$I_B = 42.5$ A $\angle -13^\circ$
$I_0 = 7.8$ A $\angle -81^\circ$	$I_C = 40.0$ A $\angle -161^\circ$
$V_1 = 28.0$ V $\angle -1.3^\circ$	$V_A = 84.0$ V $\angle -1.3^\circ$
$V_2 = 28.0$ V $\angle -1.3^\circ$	$V_B = 0.0$ V $\angle 0^\circ$
$V_0 = 28.0$ V $\angle -1.3^\circ$	$V_C = 0.0$ V $\angle 0^\circ$

Ground distance relays employ a zero sequence current compensation factor,  $K_0$ , in the operating quantity is to allow the ground distance relay to measure the proper impedance to the fault based on the positive sequence impedance of the line. However, this same zero sequence current compensation factor may cause a misoperation of the forward looking element on the unfaulted phase during an external double line to ground fault such as the one in Figure 8. Assume that the over reaching ground distance function has the settings shown below. Note that the reach of the unit is only set equal to the line impedance, in actual practice a longer reach setting would be desired to cover the apparent impedance due to infeed with a safety margin.

## ZONE 2 SETTINGS

$$Z_{R1} = 6.0 \Omega$$

$$Z_{R0} = Z_{R1}$$

$$\angle Z_{R1} = 87^\circ$$

$$K_0 = 3 \angle -11^\circ$$

Consider a simple phase A ground distance relay at Bus C looking towards Bus A having an operating quantity of:

$$(I_A - I_0) \cdot Z_{R1} + K_0 \cdot I_0 \cdot Z_{R1} - V_{AG} \quad (8)$$

The voltage phasors comprising the operating signal are shown in Figure 9; The  $(I_A - I_0) \cdot Z_{R1}$  term is neglected because of its low magnitude. Note that magnitude of the zero sequence current term is larger than that of the restraint voltage  $V_{AG}$ , and therefore this unit will operate. The phase A function operates for this condition, even though the phase A current is low and the fault is a reverse BCG. The choice of polarizing signal for the ground distance relay will have little effect on the performance for this situation; other means must be used to prevent misoperation, either in the design of the relay, or in the application and setting of the relay. This problem does not typically arise on a two terminal line application because the zero sequence current is limited by the impedance of the transmission line and extremely long reaches are not required.

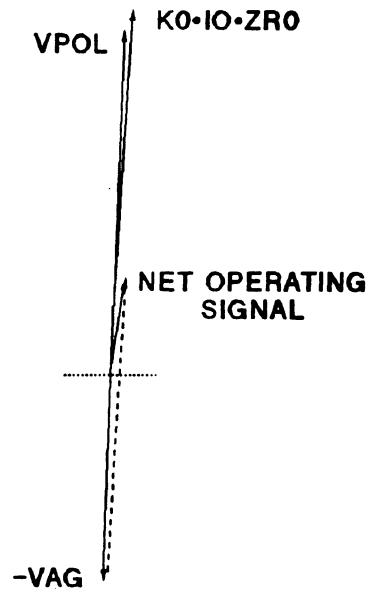

Figure 9

### *Effects of Fault Resistance*

The effect of fault resistance on ground distance functions has been well documented in the past. On three terminal lines, the effect of the infeed from the third terminal is to further magnify the apparent fault resistance. This will reduce the actual fault resistance for which the ground distance functions will operated.

## Blocking Functions

In the Directional Comparison Blocking and the Hybrid schemes, the blocking functions must be set to coordinate with the overreaching distance functions at the remote terminals. The reach of blocking function must be set to see all faults for which the tripping functions can operate, with a safety margin. Typically, the blocking functions would be set with a margin of at least 25% of the remote overreaching function with the greatest overreach. The greatest overreach will occur when one of the breakers is open and the infeed current is removed. For the example shown in Figure 10, the blocking function reach at terminal C would be set to at least the larger of:

$$BLK_C = 1.25 \cdot OR_A - (Z_{AT} + Z_{TC}) \quad (8)$$

or

$$BLK_C = 1.25 \cdot OR_B - (Z_{BT} + Z_{TC}) \quad (9)$$

Where:

$BLK_C$  is the minimum desired reach setting for the blocking function at C.

$OR_A$  is the reach setting of the overreaching function at terminal A.

$OR_B$  is the reach setting of the overreaching function at terminal B.

$Z_{AT}$  is the positive sequence impedance from A to the tap location.

$Z_{BT}$  is the positive sequence impedance from B to the tap location.

$Z_{CT}$  is the positive sequence impedance from C to the tap location.

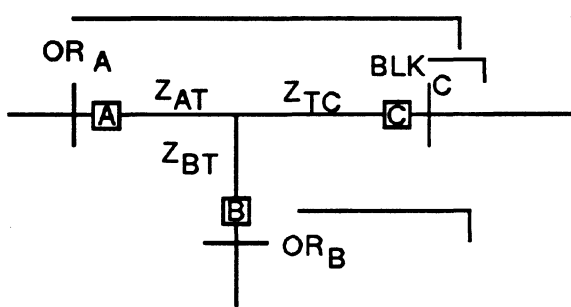

Figure 10

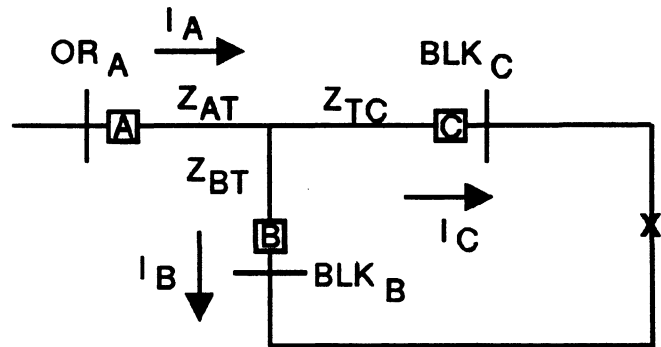

Figure 11

If the overreaching distance functions at a remote terminal have a large reach to accommodate the effects of infeed current, the blocking function may also require a large reach in order to coordinate with the trip functions. This large reach may cause the blocking functions to operate on high load for some system conditions. If this is undesirable, then the reach of the blocking functions must be reduced to prevent operation, and the reach of the remote overreaching functions must be reduced to coordinate with the reach of the blocking functions.

Current outfeed conditions will present additional considerations in setting the blocking functions. Consider the system of Figure 11. For an external fault at X, the overreaching relay at A will see the parallel impedance between the tap and the fault. The blocking functions at B and C will see less current than the relay at A and will see the actual impedance from their location to the fault. It is still desirable that the blocking units be set with a margin equal to 25% of the setting of the larger of the remote overreaching functions. In order to arrive at blocking function settings which are safe for this outfeed conditions with a minimum of calculations, it can be assumed that the

current is divided equally between the two outfeed terminals. With this assumption, the reach of the blocking functions at terminals B and C may be set to:

$$\text{BLK}_C = 2.5 \cdot \text{OR}_A - 2 \cdot Z_{AT} - Z_{TC} \quad (10)$$

$$\text{BLK}_B = 2.5 \cdot \text{OR}_A - 2 \cdot Z_{BT} - Z_{TB} \quad (11)$$

If the reaches determined by the above equations produce undesirably long reaches that compromise the load capability of the line, and if there is some minimum value of infeed current at terminal B or C for external faults, then it is possible to reduce the reach setting of the blocking functions at B, or C, or both. This is possible because the infeed current increases the apparent impedance of the circuits emanating from B and/or C. For the current outfeed case, the blocking unit reaches must also meet the requirements of equations 8 and 9 to insure proper coordination when one breaker is open.

## CHANNEL CONSIDERATIONS

The use of distance relaying schemes on multi-terminal lines not only complicates the setting considerations for the distance functions, it also affects the relaying channel.

### On-Off (AM) Power Line Carrier Channel

When a blocking scheme is applied on a multi-terminal line using On-Off type power line carrier equipment, only one transmitter and one receiver are required at each line terminal. When On-Off PLC is used, all transmitters have the same nominal frequency, and all remote receivers can respond to the receipt of any remote blocking signal. If more than one transmitter is sending the same frequency, it is possible that the signals will interact with one another causing beat frequencies and/or cancellation of the transmitted frequency. It is therefore a standard practice to slightly offset the transmitter frequencies at each terminal to prevent signal cancellation. There is no additional cost involved in the application of the On-Off carrier to multi-terminal lines.

### Frequency Shift (FSK) Channels

Frequency shift channels may be used in PUTT, POTT, and Hybrid distance schemes. Frequency shift channels may be used over the power line (PLC), over microwave, or fiber. When FSK channels are used, the equipment at each line terminal must consist of one transmitter (with a different frequency for each line terminal) and one receiver for each of the remote terminals. Thus for a three terminal line application, the FSK equipment at each terminal will include one transmitter and two receivers. The transmitter at each terminal will be at a different frequency. Therefore, additional FSK receivers must be added for multi-terminal line applications.

## CONCLUSION

There is an infinite variety of three terminal line configurations. This complicates the application of distance relays on these line. The user may be required to compromise the relay settings. In some applications, it may be possible to set the phase distance relays to provide adequate

coverage for the line, but encounter problems with the ground distance relay settings. For example, the zero sequence infeed from a terminal with a grounded wye transformer may so magnify the apparent zero sequence impedance that it may not be possible to see single line to ground faults that include fault resistance. In these cases, it may be necessary to use ground directional overcurrent functions to supplement, or replace, the ground distance relays.

The traditional protective schemes described herein were first developed for electromechanical relays. In these electromechanical schemes there is a cost penalty for added zones of protection, thus a POTT scheme might be applied without Zone 1 distance functions, and a Blocking or Hybrid scheme might be viewed as more costly than a POTT or DUTT scheme. With today's integrated packages of both analog and digital design, the cost penalty for added zones of protection is minimal, or in some cases non-existent. Therefore the protection engineer has more flexibility to design a better scheme for the protection of three terminal lines.

#### BIBLIOGRAPHY

IEEE PSRC Report, "Protection Aspects of Multi-Terminal Lines," IEEE publication 79 TH0056-2-PWR, 1979.

J. L. Blackburn, *Protective Relaying: Principles and Applications*. New York: Marcel Dekker Inc., 1987.

G. E. Alexander, J. G. Andrichak, and S. D. Rowe, "Evaluating Line Relaying Schemes in Terms of Speed, Security, and Dependability," *Twenty First Annual Western Protective Relaying Conference*, October 1994.

G. E. Alexander and J. G. Andrichak, "Ground Distance Relaying: Problems and Principles," *Eighteenth Annual Western Protective Relaying Conference*, October 1991.