

# Advanced Protection and Control for a Power System Serving Industrial Customers

Marco F. Jorge, *Iberdrola Energía Monterrey*

David Sánchez, Héctor J. Altuve, and Jorge L. Soto, *Schweitzer Engineering Laboratories, Inc.*

**Abstract**—To serve industrial customers in the Monterrey, México area, Iberdrola Energía Monterrey completed a project that consisted of building five 115/13.8 kV substations, several 115 kV lines, and the protection and control system for the 115 kV and 13.8 kV networks. In this paper, we describe the protection and control system of the 115 kV network, which uses multifunction relays with communications and logic programming abilities. We describe an adaptive protection and control logic that allows operators to reconfigure the network for some permanent faults and adapts relay settings to the new network configuration. We show the results of a PCS factory-staged test, provide system operation statistics, and describe the protection scheme operation for an actual fault event.

## I. INTRODUCTION

Until 2000, the Planta Eléctrica del Grupo Industrial (PEGI) power system was a 13.8 kV network isolated from the Comisión Federal de Electricidad (CFE) system. The PEGI system fed several industrial customers from PEGI I and PEGI II power stations. Iberdrola Energía Monterrey acquired PEGI in 2000 and started a power system modernization project, called the ALFA-PEGI project. This project included building five 115/13.8 kV substations (MONTERREY III, FIQUISA, PEGI I, PEGI II, and NYLON), and building a looped 115 kV network to interconnect these substations. The new system is connected to the CFE system at the MONTERREY III power station and supplies energy to CFE and the industrial customers under a long-term contract.

The project also included building the protection and control system (PCS) for the 115 kV and 13.8 kV networks, and the integrated systems for the new substations. The PCS uses multifunction relays to provide redundant line and transformer protection. Protection of 115 kV lines includes a line differential scheme and a directional-comparison scheme using fiber-optic communication.

A set of motor-operated disconnect (MOD) switches allows operators to reconfigure the 115 kV loop in such a way that, when a fault causes a line loss, one of the substations becomes a tapped load. When this network reconfiguration occurs, the PCS switches the line differential protection schemes from two-terminal to three-terminal configurations. The PCS also modifies the settings of the backup line protection schemes to adapt them to the new network topology. Fiber-optic communication and the adaptive PCS logic allow personnel to perform switching operations and trigger relay settings changes without traveling to the substations.

In this paper, we describe the PCS of the 115 kV network and the adaptive logic. We show the result of a PCS factory-staged test, provide system operation statistics, and discuss protection scheme operation for an actual fault event.

## II. POWER SYSTEM DESCRIPTION

The 115 kV transmission system (see Fig.1) includes two lines between the Monterrey III power station and the PEGI II

load. Hence, loss of one line does not interrupt power supply to the system.

The 115 kV loop connecting PEGI II, PEGI I, NYLON, and FIQUISA substations ensures power supply to loads at PEGI I, NYLON, and FIQUISA substations even upon loss of any of the loop lines. Only the simultaneous loss of the two lines feeding the NYLON substation from the FIQUISA and PEGI I substations would cause service interruption to the NYLON substation.

PEGI II, PEGI I, and NYLON substations have ring-bus arrangements. FIQUISA substation has a single bus configuration.

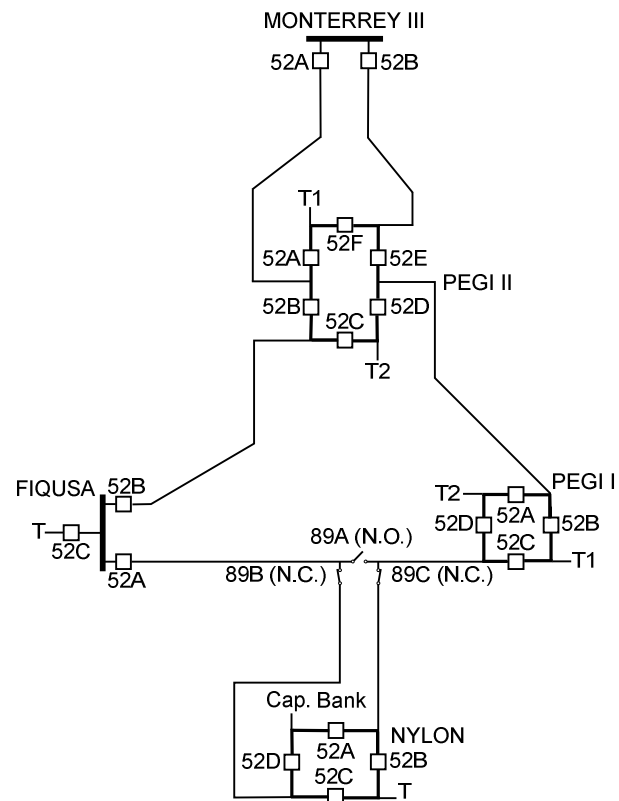

Fig. 1. One-line diagram of the 115 kV transmission system.

In the 115 kV system, the NYLON-FIQUISA and NYLON-PEGI I lines run on the same poles over 10 km starting at NYLON substation (see Fig. 1).

The set of MOD switches 89A, 89B, and 89C (see Fig. 1 and Fig. 2), located at the end of the double-circuit line section, allows the system operator to isolate permanent faults on one or both lines, and reconfigure the network. This network reconfiguration, described in Section IV, restores looped operation to improve voltage regulation and enhance system reliability. The reconfigured system requires different line protection settings. The adaptive protection and control logic described in Section IV makes the required settings changes.



Fig. 2. View of the 115 kV MOD switch on the PEGI I-NYLON line (Switch 89C in Fig. 1).

### III. PROTECTION AND CONTROL SYSTEM

#### A. Design Requirements

Meeting the industrial customer demand for high service continuity requires dependable and fast protection. The design requirements of the protection system include:

- Dual primary line protection, including differential and directional-comparison protection schemes.
- Line backup protection, including phase and ground distance protection and ground directional overcurrent protection.
- Breaker-failure protection on 115 kV breakers.
- Automatic reclosing with loss-of-voltage supervision of 115 kV breakers.
- Dual transformer protection, including differential, phase overcurrent, and ground overcurrent protection.
- Bus protection schemes adapted to the bus arrangement of each substation.
- Protection for the 13.8 kV distribution circuits, including overcurrent protection and automatic reclosing.

The integrated system includes one integrated PCS per each 115/13.8 kV substation. The substation integrated systems communicate with the Control and Measurement Center, which is the Iberdrola Energia Monterrey SCADA center.

The substation integrated systems perform these functions:

- Local control.
- Acquiring, storing, and displaying measured values, status data, and alarms.
- Automatically retrieving and storing relay oscillographic records.
- Sequential event recording.

- Acquiring, storing, and displaying breaker monitoring information.
- Acquiring, storing, and displaying energy consumption information.
- Maintaining an updated database of relay and communications processor settings.
- Communicating with the Control and Measurement Center.

Reference [1] describes the integrated system, which is outside the scope of this paper.

#### B. System Description

The PCS uses multifunction relays with communications and logic programming abilities. These relays provide all the protection functions, as well as the control and monitoring functions required by the substation integrated systems.

##### 1) Transmission Line Protection

Two multifunction relays provide redundant primary and backup line protection. Each relay provides these protection functions:

- Line differential protection (87L).
- Line directional-comparison protection (85L).
- Phase and ground distance protection (21/21N).
- Negative- and zero-sequence directional overcurrent protection (67Q/67N).
- Breaker-failure protection (50BF).
- Automatic reclosing, including 79 and 25/27 functions.

Because each multifunction relay provides differential and directional-comparison protection, each line has dual differential and dual directional-comparison protection.

Differential protection uses phase and negative- or zero-sequence differential elements to provide phase and ground fault protection.

Directional comparison protection consists of a permissive overreaching transfer trip (POTT) scheme that uses distance and directional elements for directional discrimination.

Relays communicate over fiber-optic channels that use the optical power ground wire (OPGW) cable mounted on each 115 kV line. Each multifunction relay has two serial ports for differential protection communication and two serial ports that support a proprietary peer-to-peer communications protocol. Table I shows the series communications ports enabled in the relays at the different substations. Section IV shows that relays at FIQUSA and PEGI I substations use ports X and Y when their differential elements serve as the master for three-terminal line configurations. Relays use the serial ports that support the peer-to-peer communications protocol for directional comparison protection and for communicating the analog and digital data that the integrated system requires. The relays can also monitor communications channels.

TABLE I

COMMUNICATIONS PORTS USED BY LINE PROTECTION RELAYS

Substation	Differential Protection Port X	Differential Protection Port Y	Port Supporting Peer-to-Peer Comm. Protocol
FIQUSA	✓	✓	✓
PEGI I	✓	✓	✓
NYLON	✓		✓
PEGI II	✓		✓

## 2) Transformer Protection

Two multifunction relays provide redundant primary and backup transformer protection. Each relay provides these protection functions:

- Differential protection (87T).
- Overcurrent protection
  - High-voltage side: 50/51/51Q/51N.
  - Low-voltage side: 51/51N, 51G.

## 3) Bus Protection

A bus differential relay protects the single bus in the FIQUUSA substation. The ring buses of PEGI I, PEGI II, and NYLON substations do not require differential protection. In these buses, one multifunction relay per breaker provides these functions:

- Breaker-failure protection (50BF).
- Automatic reclosing, including 79 and 25/27 functions.

## 4) Distribution Feeder Protection

One multifunction relay for each 13.8 kV distribution feeder provides these functions:

- Overcurrent protection (50/51).
- Automatic reclosing (79).

## IV. ADAPTIVE PROTECTION AND CONTROL LOGIC

Fig. 3 shows the 115 kV loop, including the double-circuit line that runs between the NYLON substation and the location of the MOD switches. Under normal operating conditions, Switch 89B and Switch 89C are closed, and Switch 89A is open.

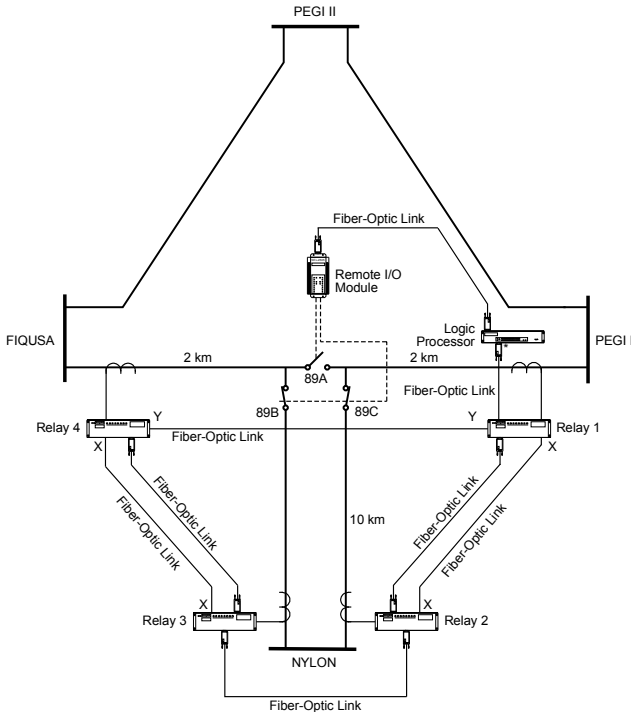

Fig. 3. The adaptive protection and control logic runs on a logic processor located at PEGI I substation.

For normal operating conditions, the relays shown in Fig. 3 are configured and set for protecting a transmission loop composed by four two-terminal lines that interconnect all four

substations. Settings Group 1, the group of settings of relays 1, 2, 3, and 4 for normal operating conditions, includes:

- Differential elements:
  - Relay 1 (PEGI I): Configured for two terminals. Uses Port X for the PEGI I-NYLON line; Port Y is disabled.
  - Relay 2 (NYLON): Configured for two terminals. Uses Port X for the PEGI I-NYLON line.
  - Relay 3 (NYLON): Configured for two terminals. Uses Port X for the NYLON-FIQUUSA line.
  - Relay 4 (FIQUUSA): Configured for two terminals; uses Port X for the NYLON-FIQUUSA line; Port Y is disabled.
- Distance and directional overcurrent elements, set for the system normal looped configuration.

A permanent fault involving both lines of the double-circuit section would interrupt service to the NYLON substation and leave the tie between the FIQUUSA and PEGI I substations open. A permanent fault on one of the lines leaves NYLON substation fed radially from either FIQUUSA or PEGI I substations. In any of these cases, the 115 kV system would temporarily operate as a radial system, which affects voltage regulation and system reliability.

The adaptive protection and control logic developed in this project performs these functions:

- Allows the power system operator to remotely operate switches 89A, 89B, and 89C to isolate the fault and restore the looped network configuration.
- Upon operator request, changes settings groups to relays 1, 2, 3, and 4.

The adaptive protection and control logic runs on a logic processor located at the PEGI I substation. The logic processor performs user-programmed logic operations on discrete input signals. This processor communicates via optical fiber with the remote I/O (RIO) module and with Relay 1 at PEGI I substation (see Fig. 3).

The RIO module, mounted on the same pole as one of the MOD switches, can control eight discrete contact outputs and transmit the state of eight contact inputs. The RIO module collects switch status information and sends control commands to the switch motors via copper cables. It communicates with the logic processor via optical fiber.

Operators can send control commands to the MOD switches either from the Control and Measurement Center (not shown in Fig. 3) or from the PEGI I substation. The logic processor receives these control commands from the HMI computer at the PEGI I substation, which may also receive these commands from the Control and Measurement Center. The logic processor supervises the received control commands with permissive signals and transmits the resulting commands to the MOD switches via the RIO module.

The logic processor receives MOD switch status information from the RIO module and breaker status information from relays 1, 2, 3, and 4 (via Relay 1). Upon operator request, the adaptive logic in the logic processor processes this information, determines the relay settings group required by the new network configuration, and generates a control command to change settings to relays 1, 2, 3, and 4. Settings group changes respond to three different contingencies.

### A. Contingency 1: Permanent Fault on the Double-Circuit Section of the NYLON-FIQUUSA Line

For this fault, line protection trips the NYLON-FIQUUSA line, leaving the NYLON substation fed from the PEGI I

substation. The transmission system becomes a radial system with two feeders.

The operator performs these operations (see Fig. 3):

- Opens Switch 89B to isolate the fault.
- Closes Switch 89A to create a direct link between FIQUSA and PEGI I substations.
- Sends a command for the logic processor to determine the required relay settings group and trigger the relay settings change.
- Recloses the breaker that tripped at FIQUSA substation to create a new loop connecting PEGI II, PEGI I, and FIQUSA substations.

Fig. 4 shows the result of switching operations. The NYLON substation becomes a tapped load, creating a three-terminal line that connects this substation with PEGI I and FIQUSA substations. This line is part of the loop connecting PEGI II, PEGI I, and FIQUSA substations.

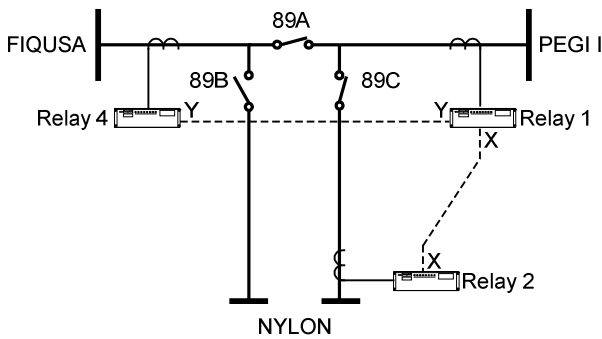

Fig. 4. For Contingency 1, the switching operations create a three-terminal line.

Fig. 5 shows the control logic that supervises the switch control commands sent by the operator.

The following conditions supervise the Switch 89B opening command for Contingency 1 (see Fig. 5(a)):

- NYLON-FIQUSA line open.
- Switch 89A open.

The following conditions supervise the Switch 89A closing command for Contingency 1 (see Fig. 5(b)):

- NYLON-FIQUSA line open.
- Switch 89B open.

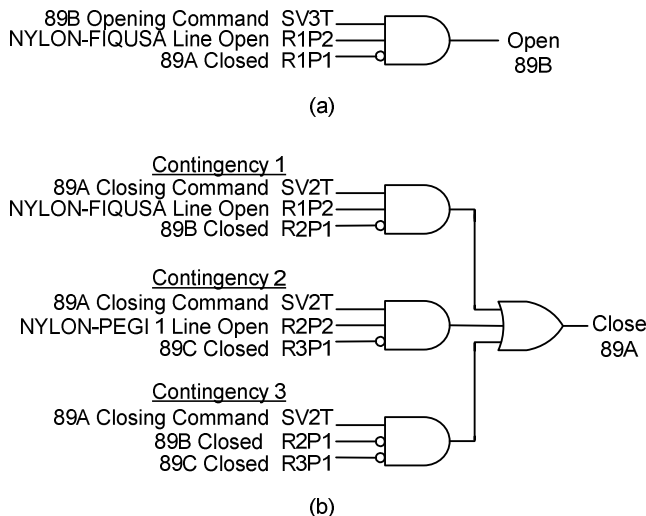

Fig. 5. Control logic that supervises operator switch control commands.

Declaring the NYLON-FIQUSA line open requires the logic processor to process information that it receives from Relay 4 (FIQUSA) and Relay 3 (NYLON) through Relay 2 (NYLON) and Relay 1 (PEGI I) (see Fig. 3). Fig. 6 shows the control logic programmed in these relays and the logic processor to generate the NYLON-FIQUSA Line Open bit.

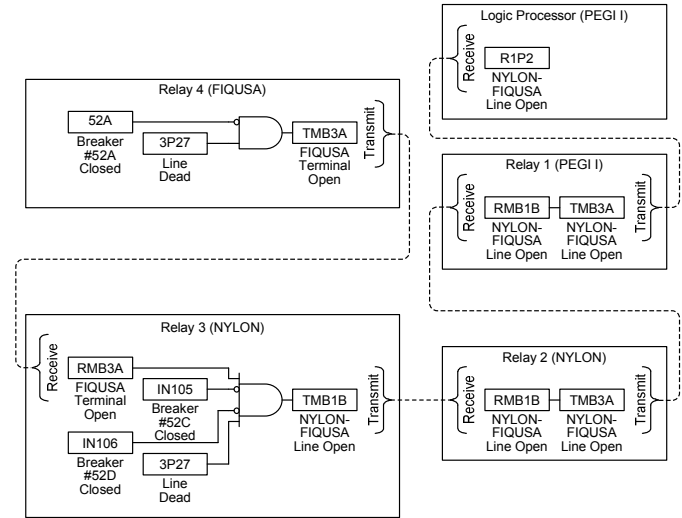

Fig. 6. Logic for declaring the NYLON-FIQUSA line open.

After making the MOD switch operations, the operator declares a contingency by sending a control command to the logic processor. The logic processor analyzes the system configuration, identifies Contingency 1 conditions, and generates the control command to change relays 1, 2, 3, and 4 to Settings Group 2. This group includes:

- Differential elements:
  - Relay 1 (PEGI I): Configured as the master for three terminals. Uses Port X and Port Y.
  - Relay 2 (NYLON): Configured as a slave for three terminals. Uses Port X.
  - Relay 3 (NYLON): Blocked.
  - Relay 4 (FIQUSA): Configured as a slave for three terminals. Uses Port Y.
- Distance and directional overcurrent elements, set for the configuration shown in Fig. 4.

Fig. 7 shows the control logic programmed in the relays and the logic processor to change the relay settings.

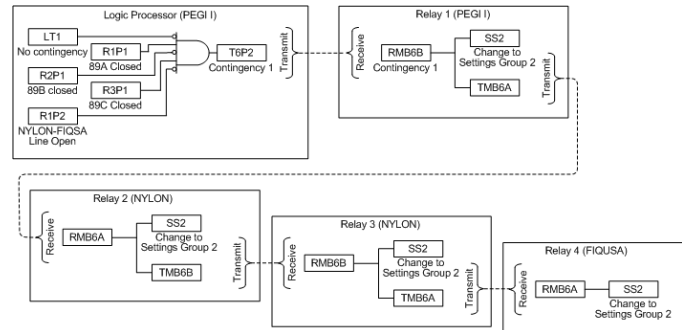

Fig. 7. Logic for changing relay settings to Settings Group 2.

Fig. 8 shows the control logic programmed in the relays and the logic processor to validate that the relays have the correct settings group.

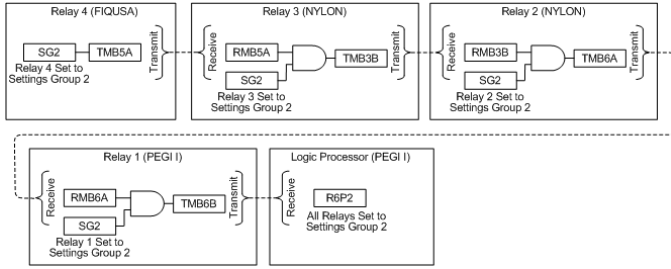

Fig. 8. Logic for validating relay settings changes.

### B. Contingency 2: Permanent Fault on the Double-Circuit Section of the NYLON-PEGI I Line

For this fault, line protection trips the NYLON-PEGI I line, leaving the NYLON substation fed radially from FIQUSA substation.

The operator performs these operations (see Fig. 3):

- Opens Switch 89C.
- Closes Switch 89A.
- Sends a command for the logic processor to determine the required relay settings group and trigger the relay settings change.
- Recloses the breakers that tripped at PEGI I substation.

Fig. 9 shows the result of switching operations. NYLON substation becomes a tapped load. The system is a loop that connects PEGI II, PEGI I, and FIQUSA substations.

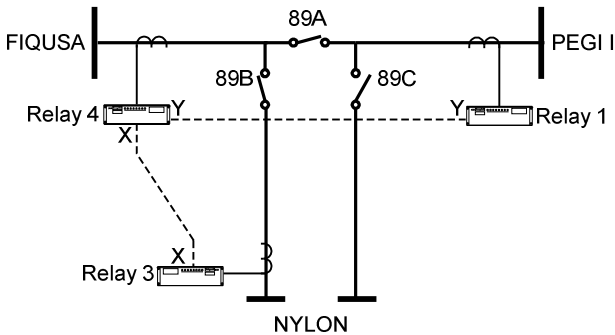

Fig. 9. For Contingency 2, the switching operations create a three-terminal line.

After making the MOD switch operations, the operator sends a control command to the logic processor, which identifies Contingency 2 conditions and generates the control command to change relays 1, 2, 3, and 4 to Settings Group 3. This group includes:

- Differential elements:
  - Relay 1 (PEGI I): Configured as a slave for three terminals. Uses Port Y.
  - Relay 2 (NYLON): Blocked.
  - Relay 3 (NYLON): Configured as a slave for three terminals. Uses Port X.
  - Relay 4 (FIQUSA): Configured as the master for three terminals. Uses Port X and Port Y.
- Distance and directional overcurrent elements, set for the configuration shown in Fig. 9.

### C. Contingency 3: Permanent Simultaneous Fault on the Double-Circuit Section Involving NYLON-FIQUSA and NYLON-PEGI I Lines

For this fault, line protection trips NYLON-PEGI I and NYLON-FIQUSA lines, interrupting service to NYLON substation. PEGI I and FIQUSA substations are fed radially from PEGI II substation.

The operator performs these operations (see Fig. 3):

- Opens Switch 89B and Switch 89C.
- Closes Switch 89A.
- Sends a command for the logic processor to determine the required relay settings group and trigger the relay settings change.
- Recloses the breakers that tripped at PEGI I and FIQUSA substations.

Fig. 10 shows the result of switching operations. The system is a loop connecting three substations. NYLON substation has no service.

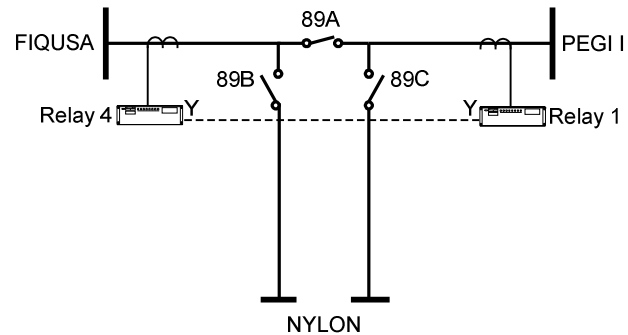

Fig. 10. For Contingency 3, NYLON substation loses service, and the switching operations create a loop that connects three substations.

After making the MOD switch operations, the operator sends a control command to the logic processor, which identifies Contingency 3 conditions, and generates the control command to change relays 1, 2, 3, and 4 to Settings Group 4. This group includes:

- Differential elements:
  - Relay 1 (PEGI I): Configured for two terminals. Uses Port Y.
  - Relay 2 (NYLON): Blocked.
  - Relay 3 (NYLON): Blocked.
  - Relay 4 (FIQUSA): Configured for two terminals. Uses Port Y.
- Distance and directional overcurrent elements, set for the configuration shown in Fig. 10.

## V. FACTORY-STAGED TESTS

The PCS was thoroughly tested in the factory. We staged the whole system and used relay test sets to apply faults.

Fig. 11 shows the result of one of the staged tests, a permanent fault on the NYLON-FIQUSA line that simulates Contingency 1. From the sequential event record, we conclude:

- The logic processor and the relays correctly execute the logic shown in Fig. 7:
  - The logic processor asserts bit T6P2 (Contingency 1 Declaration).
  - Relay 1 (PEGI I) asserts bits RMB6B and TMB6A.

- Relay 2 (NYLON) asserts bits RMB6A and TMB6B.
- Relay 3 (NYLON) asserts bits RMB6B and TMB6A.
- Relay 4 (FIQUSA) asserts bit RMB6A.
- The relays correctly execute the logic shown in Fig. 8 and confirm that relay settings changed:
  - Relay 4 (FIQUSA) asserts bit TMB5A.
  - Relay 3 (NYLON) asserts bit TMB3B.
  - Relay 2 (NYLON) asserts bit TMB6A.
  - Relay 1 (PEGI I) asserts bit TMB6B.
  - All relays assert bit SG2 (Enable Settings Group 2).
  - All relays declare “Relay Settings Changed”.
  - The logic processor asserts bit R6P2 (All Relays Set to Settings Group 2) 1160 ms after sending bit T6P2.
- Relay 3 (NYLON) asserts the Channel X Alarm bit (CHXAL), which confirms blocking of the differential element.
- Relay 4 (FIQUSA) deasserts the Channel Y Alarm bit (CHYAL), which confirms Channel Y enabling.

Logic Processor					Date: 08/01/04	Time: 19:40:26.047
#	DATE	TIME	ELEMENT	STATE		
6	08/01/04	19:39:54.002	T5P2	Deasserted		
5	08/01/04	19:39:54.002	T6P2	Asserted		
4	08/01/04	19:39:55.130	R3P2	Deasserted		
3	08/01/04	19:39:55.162	R6P2	Asserted		
2	08/01/04	19:39:58.462	R6P2	Deasserted		
1	08/01/04	19:39:58.638	R6P2	Asserted		

Relay 1 87 L					Date: 08/01/04	Time: 19:41:05.946
#	DATE	TIME	ELEMENT	STATE		
10	08/01/04	19:39:54.015	RMB5B	Deasserted		
9	08/01/04	19:39:54.015	RMB6B	Asserted		
8	08/01/04	19:39:54.015	TMB5A	Deasserted		
7	08/01/04	19:39:54.015	TMB6A	Asserted		
6	08/01/04	19:39:55.094	SG2	Asserted		
5	08/01/04	19:39:55.094	SG1	Deasserted		
4	08/01/04	19:39:55.152	TMB6B	Asserted		
3	08/01/04	19:39:58.423	Relay settings changed	Deasserted		
2	08/01/04	19:39:58.423	TMB6B	Deasserted		
1	08/01/04	19:39:58.624	TMB6B	Asserted		

Relay 2 NYLON					Date: 08/01/04	Time: 19:41:36.977
#	DATE	TIME	ELEMENT	STATE		
15	08/01/04	19:39:54.026	RMB5A	Deasserted		
14	08/01/04	19:39:54.026	RMB6A	Asserted		
13	08/01/04	19:39:54.026	TMB5B	Deasserted		
12	08/01/04	19:39:54.026	TMB6B	Asserted		
11	08/01/04	19:39:55.110	SG2	Asserted		
10	08/01/04	19:39:55.110	SG1	Deasserted		
9	08/01/04	19:39:55.110	TMB5A	Deasserted		
8	08/01/04	19:39:55.127	RMB2B	Deasserted		
7	08/01/04	19:39:55.143	RMB3B	Asserted		
6	08/01/04	19:39:55.143	TMB6A	Asserted		
5	08/01/04	19:39:55.547	RMB6A	Deasserted		
4	08/01/04	19:39:55.547	TMB6B	Deasserted		
3	08/01/04	19:39:58.602	Relay settings changed	Deasserted		
2	08/01/04	19:39:58.619	RMB6A	Asserted		
1	08/01/04	19:39:58.619	TMB6B	Asserted		

Relay 3 NYLON					Date: 08/01/04	Time: 19:42:07.440
#	DATE	TIME	ELEMENT	STATE		
14	08/01/04	19:39:54.040	RMB5B	Deasserted		
13	08/01/04	19:39:54.040	RMB6B	Asserted		
12	08/01/04	19:39:54.040	TMB5A	Deasserted		
11	08/01/04	19:39:54.040	TMB6A	Asserted		
10	08/01/04	19:39:55.040	CHXAL	Asserted		
9	08/01/04	19:39:55.115	SG2	Asserted		
8	08/01/04	19:39:55.115	SG1	Deasserted		
7	08/01/04	19:39:55.115	TMB2B	Deasserted		
6	08/01/04	19:39:55.132	TMB3B	Asserted		
5	08/01/04	19:39:55.561	RMB6B	Deasserted		
4	08/01/04	19:39:55.561	TMB6A	Deasserted		
3	08/01/04	19:39:58.303	Relay settings changed	Deasserted		
2	08/01/04	19:39:58.633	RMB6B	Asserted		
1	08/01/04	19:39:58.633	TMB6A	Asserted		

Relay 4 FIQUSA					Date: 08/01/04	Time: 19:42:07.440
#	DATE	TIME	ELEMENT	STATE		
9	08/01/04	19:39:54.049	RMB5A	Deasserted		
8	08/01/04	19:39:54.049	RMB6A	Asserted		
7	08/01/04	19:39:55.124	SG2	Asserted		
6	08/01/04	19:39:55.124	SG1	Deasserted		
5	08/01/04	19:39:55.124	TMB5A	Asserted		
4	08/01/04	19:39:55.570	RMB6A	Deasserted		
3	08/01/04	19:39:57.395	Relay settings changed	Deasserted		
2	08/01/04	19:39:58.641	RMB6A	Asserted		
1	08/01/04	19:40:09.739	CHYAL	Deasserted		

Fig. 11. Sequential event record for a staged fault simulating Contingency 1.

The HMI screen capture in Fig. 12 shows the confirmation that relays changed to Settings Group 2 in response to the network reconfiguration resulting from the NYLON-FIQUSA line fault.

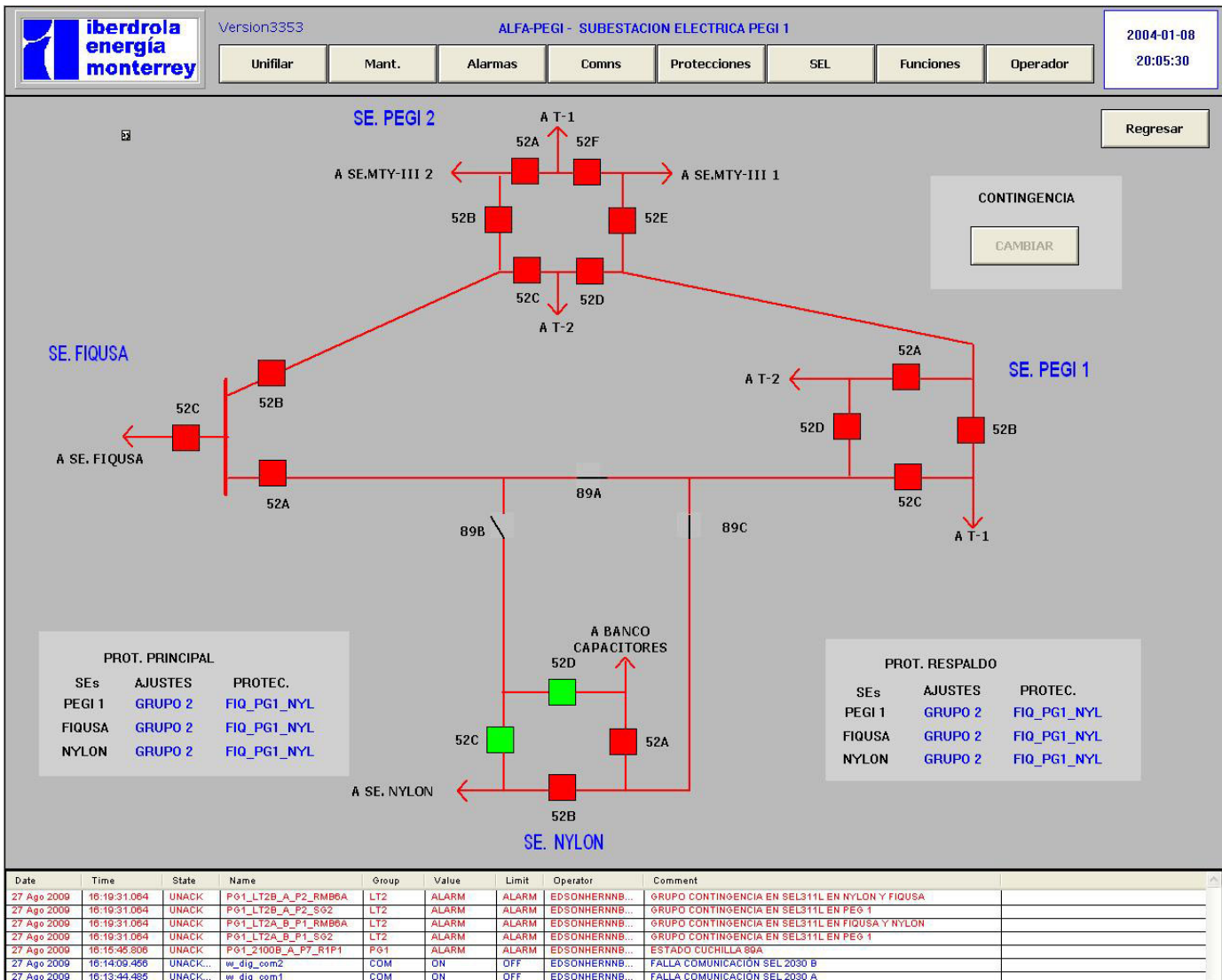

Fig. 12. HMI screen confirms that relay settings groups changed for Contingency 1 staging.

V. FIELD OPERATION EXPERIENCE

A. Protection Operation Data

Table II summarizes the field performance of the PCS line protection schemes since commissioning in 2004. The line protection schemes cleared the internal faults properly and remained secure for the external faults. No faults required the adaptive protection and control logic to operate.

TABLE II  
FIELD PERFORMANCE OF LINE PROTECTION SCHEMES

Line	Correct Trips	Correct No Trips
MONTERREY III-PEGI II (1)	12	2
MONTERREY III-PEGI II (2)	9	8
PEGI II-PEGI I	8	19
PEGI I-NYLON	10	14
NYLON-FIQUISA	6	12
FIQUISA-PEGI II	2	18
<b>Total</b>	<b>47</b>	<b>73</b>

B. Example of Scheme Operation for an Actual Fault

A single-phase-to-ground fault occurred on the PEGI I-NYLON line on February 20, 2009. From the oscillogram recorded at PEGI I substation (see Fig. 13), we conclude the following:

- The fault starts on cycle 4.31.
- The differential element (87L) trips on cycle 5.01.
- The scheme issues the breaker trip signal (TRIP) on cycle 5.01.
- The scheme operating time is 0.7 cycles.
- The fault clears on cycle 7.44.
- The total fault clearing time is 3.13 cycles.

The POTT scheme also responds to this fault, but the differential protection is faster:

- The ground Zone 2 element (Z2G) trips on cycle 5.6. The internal bit KEY of the POTT logic asserts, and a transfer trip signal is transmitted via peer-to-peer communication.
- PT bit asserts on cycle 6.8, indicating reception of the transfer trip signal from the remote end.

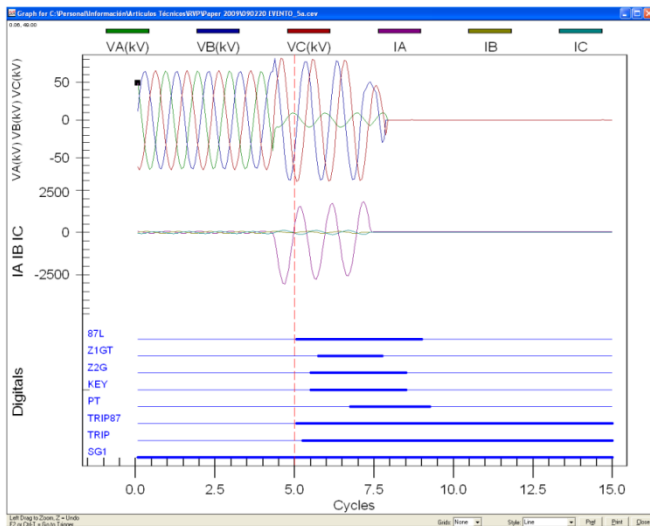

Fig. 13. Oscillogram recorded at the PEGI I terminal of the PEGI I-NYLON line.

## VI. CONCLUSIONS

- The ALFA-PEGI project provided an advanced integrated PCS for the power system serving important industrial customers in the Monterrey, México area.
- The PCS uses multifunction relays with communications and logic programming abilities, a logic processor, a remote I/O module, and fiber-optic communications channels.
- An adaptive protection and control logic that runs on the logic processor allows the system operator to remotely operate MOD switches to isolate line permanent faults and reconfigure the network. The reconfiguration improves voltage regulation and enhances system reliability.
- Upon operator request, the adaptive logic determines the settings change required to adapt the line protection relays to the new system configuration. Then, the logic processor sends a control command that triggers relay settings changes.
- Extensive factory testing of the PCS improved system reliability and showed the correct performance of the adaptive protection and control logic.
- The line protection schemes properly cleared all 47 internal faults and remained secure for all 73 external faults. No faults required the operation of the adaptive protection and control logic.

## VII. REFERENCES

- [1] C. A. Guzmán, D. Sánchez, and O. González, "Design of the protection and integration systems of Planta Eléctrica del Grupo Industrial (PEGI)," 27th Summer Power and Industrial Applications Meeting of the IEEE México Section, Acapulco, Guerrero, México, July 2004 (in Spanish).

## VIII. BIOGRAPHIES

**Marco Francisco Jorge Zavala** received his BSEE degree in 1997 from the Technologic Institute of Veracruz, Veracruz, México, and his M.Sc. in 2007 from Autonomous University of Nuevo León, Monterrey, México. From 1996 until 2001, he worked in the Control Department of the Southeastern Transmission Area of Comisión Federal de Electricidad (CFE) in Escárcega, Campeche, México. Mr. Jorge worked for Schweitzer Engineering Laboratories, S.A. de C.V. from 2004 to 2005. He joined Iberdrola Energía Monterrey in 2005, where he is currently Operations Manager of the Monterrey III combined-cycle power station.

**David Sánchez Escobedo** received his BSEE degree in 1994 from the University of Guanajuato, México. From 1994 until 1998, he was Head of the Protection and Metering Office of the Western Transmission Area of Comisión Federal de Electricidad (CFE) in Guadalajara, México. From 1996 until 1998, he took M.Sc. Degree courses at the University of Guadalajara. Mr. Sánchez served on the faculty of the Autonomous University of Guadalajara in 1998. From 1998 until 2000, he worked for INELAP-PQE in Guadalajara, México, as a Protection System Design Engineer. In September 2000, Mr. Sánchez joined Schweitzer Engineering Laboratories, S.A. de C.V., where he is currently the Electrical Engineering Manager in San Luis Potosí, México. He has authored and coauthored several technical papers.

**Héctor J. Altuve** received his BSEE degree in 1969 from the Central University of Las Villas, Santa Clara, Cuba, and his Ph.D. in 1981 from Kiev Polytechnic Institute, Kiev, Ukraine. From 1969 until 1993, Dr. Altuve served on the faculty of the Electrical Engineering School, at the Central University of Las Villas. He served as professor, Graduate Doctoral Program, Mechanical and Electrical Engineering School, at the Autonomous University of Nuevo León, Monterrey, México, from 1993 to 2000. In 1999-2000, he was the Schweitzer Visiting Professor at Washington State University's Department of Electrical Engineering. In January 2001, Dr. Altuve joined Schweitzer Engineering Laboratories, Inc., where he is currently a Distinguished Engineer and Director of Technology for Latin America. He has authored and coauthored more than 100 technical papers and holds three patents. His main research interests are in power system protection, control, and monitoring. Dr. Altuve is an IEEE Senior Member, and a PES Distinguished Lecturer.

**Jorge. L. Soto** received his BSEE degree, with specialization in electric power systems, from the Technologic Institute of Hermosillo, México in 1996. He took M.Sc. Degree courses at the Technologic Institute of Aguascalientes, México from 2005 to 2007. In 1999 he joined the Western Transmission Area of Comisión Federal de Electricidad (CFE). He was the Protection Supervisor of the southern CFE areas of Sonora and Sinaloa states from 2001 to 2006. From 2004 to 2006 he was the instructor of the course "Protection of High-Voltage Lines" at the CFE Western Training Center in Manzanillo, Colima, México. He joined Schweitzer Engineering Laboratories, S.A. de C.V., in 2007, as a protection engineer. He currently supervises the Design Pool of the SEL México Electrical Engineering Department in San Luis Potosí, México.