

Forward to the Basics: Selected Topics in Distribution Protection

Lee Underwood and David Costello, *Schweitzer Engineering Laboratories, Inc.*

Abstract—Modern relays provide protection elements that were historically not used due to cost or panel space restrictions. These new elements can provide improved protection for the power system. However, protection engineers may be unfamiliar with the behavior of these elements and may make settings choices that lead to unintended consequences. At the same time, engineers must continue to properly employ good settings practices long established for more traditional elements.

Through analysis of event reports recorded by relays, this paper will present several examples of settings that led to unintended operation of distribution protection, including transformer delta-winding residual overcurrent protection, transformer high-voltage phase overcurrent protection, and others. The nature of the unintended operations will be explored, and methods for calculating more secure settings will be discussed.

I. INTRODUCTION

Microprocessor relays offer many advantages over electromechanical devices, including the ability to provide protection elements that were historically not used due to cost or panel space limitations. In addition, many functions that used to be provided by wiring and auxiliary relays can now be implemented in the relays themselves through settings and programmable logic. These capabilities can increase the effectiveness and flexibility of protection, but protection engineers must understand how these elements behave in order to apply them properly.

II. TRANSFORMER HIGH-VOLTAGE WINDING RESIDUAL OVERCURRENT ELEMENT TRIPS FOR A LOW-VOLTAGE FAULT

Microprocessor-based transformer protection relays often provide phase and residual ground overcurrent elements for individual winding current inputs. The operating quantity for residual overcurrent elements is the phasor sum of the three-phase currents. This quantity can be derived by using a traditional residual connection of the current transformers (CTs) or by calculation within the relay itself. Since three separate CTs are involved, there will always be some “false residual” current due to dissimilar performance of the CTs.

In industrial power systems, a sensitive overcurrent relay connected to a zero-sequence CT (50G) is often used for ground fault protection of the feeder conductors and the high-voltage delta winding of a delta-*Wye* transformer (Fig. 1). With increasing use of microprocessor-based transformer differential relays, protection engineers may also apply residual overcurrent protection (50N) as backup. These residual elements provide protection for ground faults within the delta winding and can be fairly sensitive because the delta-

Wye connection obviates the need to coordinate this element with low-voltage ground fault relays. However, care must be taken when selecting pickup and time-delay settings to prevent misoperation due to false residual currents. Because the three separate CTs supplying the 50N relay will not saturate evenly during a fault, false residual currents must be expected, and the 50N relay element cannot usually be set with the same sensitivity and short time delay typical of the 50G. As stated in [1], “instantaneous overcurrent relays may be used, but sensitive settings will probably result in incorrect operations from dissimilar CT saturation and magnetizing inrush. This can be avoided by using a short-time overcurrent relay with a sensitive setting.”

Care must be exercised in understanding an element’s fundamental operation. Note that G and N may not consistently identify the operating principles of a ground element and may be used in different ways by engineers and manufacturers.

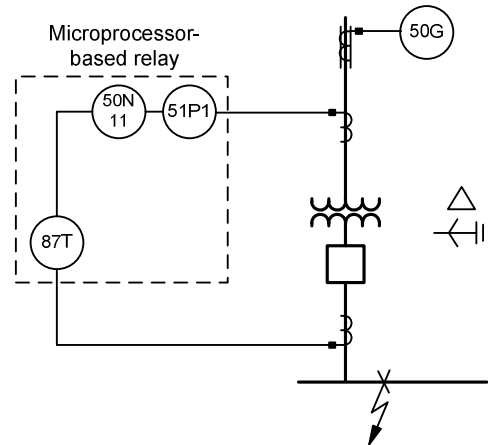

Fig. 1. Ground Overcurrent Protection for Delta-Connected Transformer Winding

Fig. 2 shows an event report captured by a transformer protection relay when a three-phase fault occurred on the low-voltage bus. The event report shows that a definite-time residual overcurrent element (50N11) on Winding 1 (the transformer high-voltage winding) asserted and tripped the breaker supplying the transformer approximately 2.5 cycles after fault inception.

This element, set to operate at 26.7 amperes primary with 1.25-cycle delay, was not intended to operate for a fault outside of the transformer zone. The value IW10Mag shows the magnitude of the zero-sequence current, I_0 , calculated by the relay. This current reached a maximum value of about 2 amperes secondary (160 amperes primary) and slowly decayed. This is false residual current that can be attributed to

dissimilar CT performance. Similar operations of very sensitive residual overcurrent elements have also been observed during transformer energization. Clearly, the possibility of poor CT performance was not considered when the setting for this element was calculated.

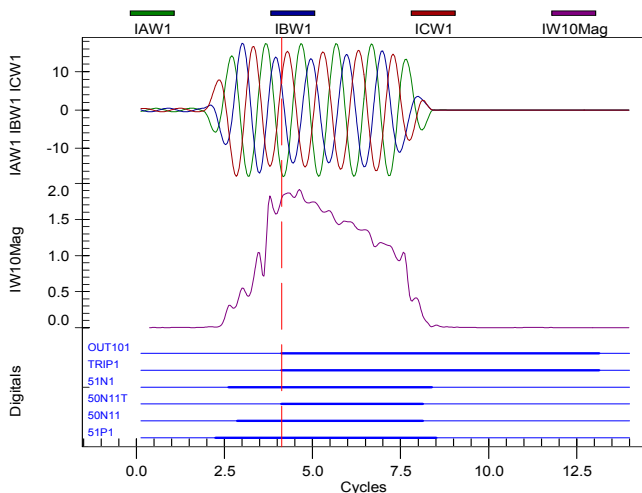

Fig. 2. Operation of Residual Overcurrent Element Due to Through Fault

CTs can saturate during inrush and through faults. The degree of saturation depends on many factors, including the current magnitude, CT secondary burden, X/R ratio, time of fault inception, and CT accuracy. In most cases, the CT saturates because of dc offset and will slowly recover to accurately replicate the primary waveform as the dc portion of the fault current subsides.

The time constant that defines the dc current rate of decay is a function of the system X/R ratio, as given by (1) and shown in Fig. 3.

$$\tau = \frac{X/R}{2\pi f} \quad (1)$$

where τ = time constant and f = frequency.

The dc offset is an exponentially decaying function with the following decay rate:

After $1 \cdot \tau$, the dc offset value has decayed 63 percent.

After $2 \cdot \tau$, the dc offset value has decayed 86 percent.

After $3 \cdot \tau$, the dc offset value has decayed 95 percent.

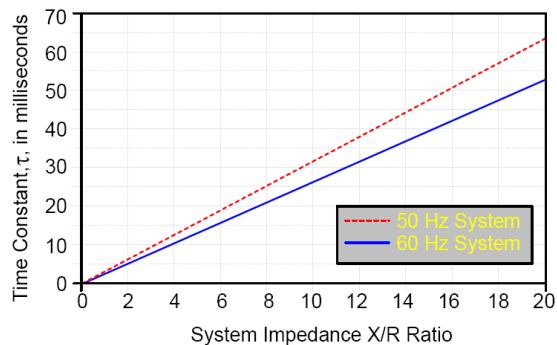

Fig. 3. X/R vs. Time Constant

At least two setting methods have been used for residual overcurrent elements for delta-connected transformer windings:

1. One major utility has traditionally set the pickup of the residual overcurrent element equal to the pickup of the phase inverse-time overcurrent element, with little or no delay. Recent operations indicate that elements set this way may still operate improperly on occasion. This method would not have been satisfactory in this example and still would have resulted in tripping the transformer for the through fault.
2. Another method is to select the pickup of the residual overcurrent element close to the full load rating of the transformer and set a definite-time delay long enough to allow the CTs to come out of saturation before the element operates.

A conservative time delay for the residual element is determined by multiplying the expected decay time of the dc offset (3 to 5 time constants) by 1.5.

For example, if the X/R is 10, the minimum recommended time delay for a 60 Hz system would be 7 to 12 cycles.

In this case, the protection engineer may have been unfamiliar with the setting criteria for the 50N element. This element was not historically used in typical industrial power system applications but was used in this application because it was available.

In all applications, CT performance should be evaluated with care. Reference [2] provides the criteria to avoid saturation and is helpful for CT selection. Remember that selecting a tap other than the full ratio reduces the accuracy of the CT. Using underrated CTs or derating a CT using less than the full ratio are two common causes of CT misbehavior.

III. TRANSFORMER HIGH-VOLTAGE WINDING PHASE OVERCURRENT ELEMENT TRIPS FOR A LOW-VOLTAGE FAULT

Fig. 4 shows an event recorded by a transformer protection relay in a retail distribution substation. This event occurred when a tree caused a phase-to-phase fault one span out of the station on one of the 12.47 kV feeders. During this event, both the primary and backup transformer protection relays operated. In the primary relay, an instantaneous phase overcurrent element (50P1) had been set to operate without delay for 10 amperes CT secondary current on the high-voltage, delta-connected winding. The element operated because the relay current for this fault exceeded 12 amperes secondary.

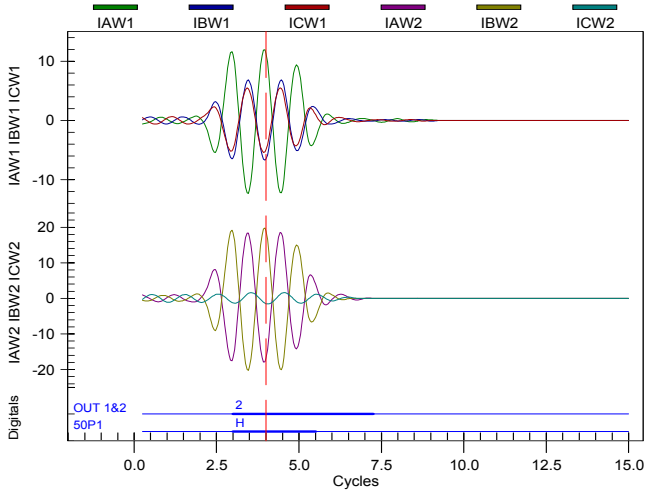

Fig. 4. Operation of Residual Overcurrent Element Due to Through Fault

This transformer is a 15/20/25 MVA, 69 kV/12.47 kV mobile transformer with 10 percent impedance. As a first approximation, the maximum available fault current for a three-phase fault on the 12.47 kV winding of this transformer, assuming no 69 kV source impedance, would be:

$$I_{HLV} = \frac{15 \text{ MVA}}{0.1 \cdot \sqrt{3} \cdot 12.47 \text{ kV}} = 6945 \text{ A} \quad (2)$$

Reflecting this to the high-voltage winding and dividing by the CT ratio (400/5), the relay current on the high-voltage winding for this fault is:

$$I_{HHV} = \frac{6945 \text{ A} \cdot \frac{12.47 \text{ kV}}{69 \text{ kV}}}{\frac{400}{5}} = 15.7 \text{ A CT secondary} \quad (3)$$

Instantaneous phase overcurrent elements applied on transformer high-voltage windings must be set so that the element will not operate for faults on the transformer secondary. Otherwise, these elements will trip for faults that should be cleared by feeder breakers, reclosers, or fuses. Traditionally, such elements would have been set to 175 to 200 percent of the expected relay current for a low-voltage fault and above relay current for inrush [1]. Such settings were required because electromechanical instantaneous overcurrent relays can operate on dc offset currents. Many microprocessor-based overcurrent relays use filtering that effectively removes the dc currents and reduces or eliminates this transient overreach. However, even with such filtering, uncertainty in fault data and relay tolerance requires settings of 125 to 150 percent of expected relay current for security.

It is obvious that some amount of 69 kV system impedance was considered when the pickup setting for the 50P1 element was established because the setting was below the fault current calculated in (3). The setting may have been appropriate for the assumed system impedance and would have provided better protection for the transformer than a higher setting. However, recall that this is a mobile transformer and, as such, is moved frequently to new locations. At different locations in the power system, the impedance of the source will vary.

In this case, the transformer was connected to the 69 kV system at a location with lower source impedance than was assumed when the setting was calculated. This increased the fault current available, and as a result, the 50P1 relay overreached and tripped improperly for a low-voltage line fault.

Although the requirements for setting 50P1 are generally well known, this example illustrates that these apparently simple setting criteria carry hidden complexities. Even when a transformer does not move, system impedances can change in the short term due to changing system alignments or in the long term due to changes in generation mix and transmission system characteristics. Protection engineers should consider how changing system impedance may affect protection.

IV. TRANSFORMER DIFFERENTIAL RELAY MISOPERATES DUE TO IMPROPER ZERO-SEQUENCE CURRENT REMOVAL

Fig. 5 shows an event captured upon the operation of a transformer differential element. This transformer is a delta-wye transformer in a retail distribution substation. As is typical for many such transformers, the neutral of the wye winding is effectively grounded. The presence of high Winding 2 current indicates that the fault is outside of the differential zone, as there is no significant source of current connected to the wye winding in this radial application.

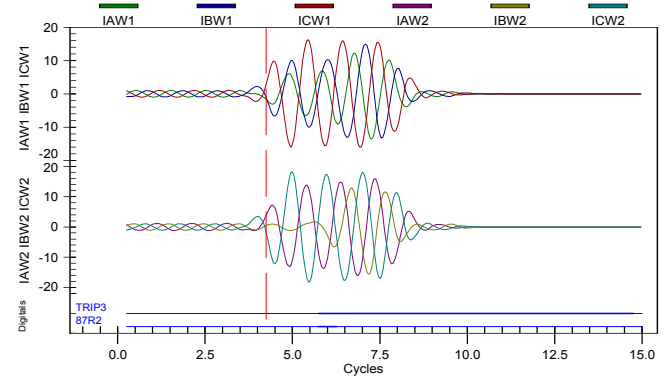

Fig. 5. Transformer Differential Relay Trips for an Out-of-Zone Fault

Fig. 6 shows the operate (IOPn) and restraint (IRTn) currents calculated by the differential relay during the through fault. Note that when the differential element operated, as indicated by the 87R2 element plot, the operate current IOP2 exceeded the corresponding restraint current IRT2, allowing the relay to operate. Of course, the differential element was never intended to operate for a fault on a feeder breaker. What was the cause of this misoperation?

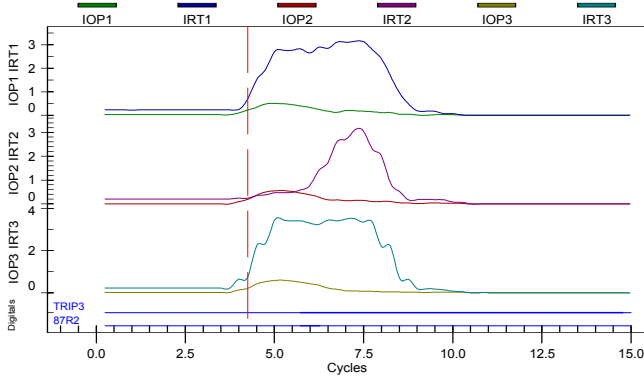

Fig. 6. Differential Relay Operate and Restraint Currents for Through Fault

In an ANSI standard transformer, the currents and voltages on the high-voltage winding will lead those on the low-voltage winding by 30 degrees. The connection that produces this phase shift is shown in Fig. 7 for a transformer with a high-voltage delta winding.

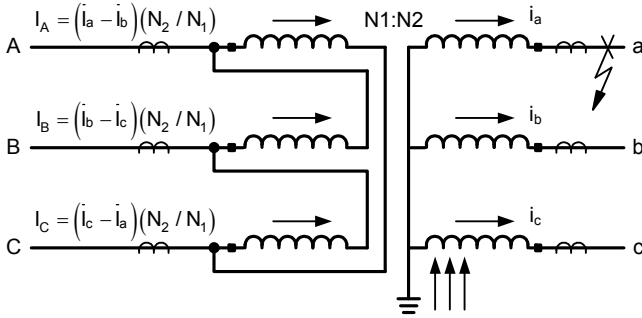

Fig. 7. Zero-Sequence Currents for Phase-to-Ground Fault on Transformer Wye Winding

Taking Phase A as an example, the current measured by the CTs in the high-voltage winding I_A is the difference between the low-voltage winding currents I_a and I_b multiplied by the turns ratio N_2/N_1 . As shown in (4), if we express the phase currents I_a and I_b as the sum of the sequence currents I_1 , I_2 , and I_0 , subtracting I_b from I_a causes the zero-sequence components of the two currents to cancel, and there will be no zero-sequence component in I_A . Thus it is often stated that the delta connection filters or traps zero-sequence currents.

$$I_a = I_1 + I_2 + I_0$$

$$I_b = a^2 I_1 + a I_2 + I_0$$

$$I_A = (I_a - I_b)(N_2 / N_1)$$

$$I_A = [I_1 + I_2 + I_0 - (a^2 I_1 + a I_2 + I_0)](N_2 / N_1) \quad (4)$$

$$I_A = [I_1(1 - a^2) + I_2(1 - a) + (I_0 - I_0)](N_2 / N_1)$$

$$I_A = [I_1(1 - a^2) + I_2(1 - a)](N_2 / N_1)$$

If a fault involving ground occurs outside of the transformer differential zone on the grounded-wye winding, zero-sequence currents will flow in the CT circuits of that winding. However, due to the delta transformer connection, no zero-sequence current will flow in the CT secondary circuits on the high-voltage winding. Unless steps are taken to remove this current from the relay input on the low-voltage winding, the differential element will operate.

Traditionally, CTs were connected in delta on the grounded-wye winding of a delta-wye transformer. This shifted the wye currents 30 degrees and adjusted the magnitude to match the high-voltage currents. This connection also removed the zero sequence from the wye-winding CT secondary circuits, thus preventing the differential element from operating on an out-of-zone ground fault.

In a typical microprocessor-based transformer differential relay application, the CTs on both the high-voltage and low-voltage windings are connected in wye. This offers many advantages, including the ability to set zero-sequence overcurrent elements, ease of setting backup phase overcurrent elements, reduced CT burden, and simplified wiring. Calculations performed in the relay provide the proper phase shift, magnitude correction, and zero-sequence current removal. However, these calculations will only be performed if the relay is made "aware" of the particular transformer and CT connections.

A survey of microprocessor-based transformer differential relays offered by several manufacturers revealed at least three methods of instructing the relay to remove zero-sequence currents from a given current input:

1. "Around-the-clock" phase angle compensation settings that specify a number of 30-degree increments to rotate the input current phasors. The phase angle compensation equations also remove zero-sequence currents. For cases where no angle compensation is required, a separate compensation setting is provided to remove zero-sequence current.
2. Around-the-clock phase angle compensation settings with a separate zero-sequence removal selection setting.
3. A setting that specifies that a grounded-wye winding or ground bank is located in the transformer differential zone.

For any of these setting methods, if the relay engineer does not recognize the need to remove zero-sequence currents and make the appropriate settings, the differential element may operate unexpectedly for ground faults outside the differential zone on the wye winding.

The relay settings for this application were correct to compensate the wye-winding currents for the 30-degree angle shift of the transformer. However, the settings did not correctly remove zero-sequence currents, as is required. Fig. 8 shows the low-voltage phase currents and the zero-sequence current on the low-voltage winding during the fault. Current magnitudes are shown on the CT secondary base. Although the phase currents indicate that the fault was initially phase-to-phase and evolved into a three-phase fault, the presence of zero-sequence current indicates ground involvement.

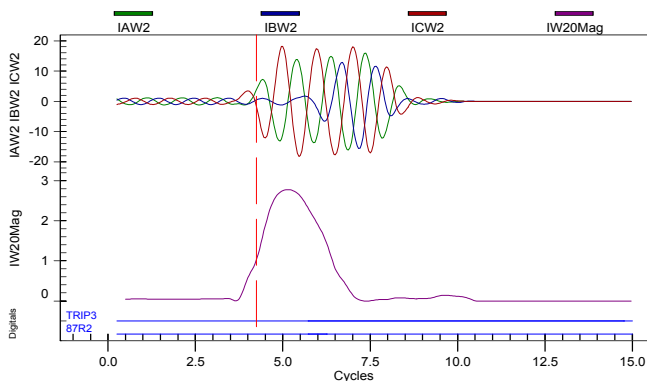

Fig. 8. Low-Voltage Winding and Zero-Sequence Currents for Through Fault

Recommendations were made to change the compensation settings to remove zero-sequence current. To test the solution, a COMTRADE file was created using the available event report data and played back to a relay with the correct settings. As shown in Fig. 9, the operate current is low, the restraint current is high, and the relay restrains for the through fault as expected.

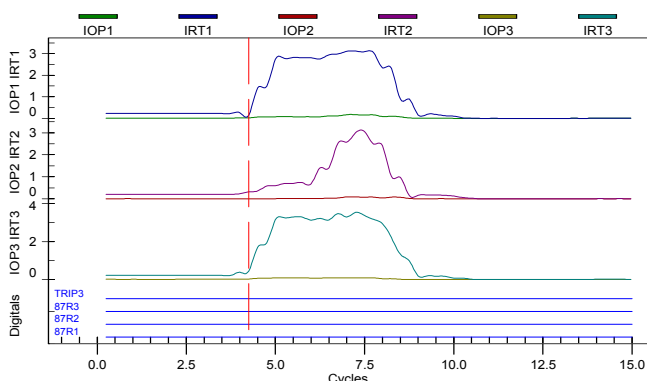

Fig. 9. Differential Relay Operate and Restraint Currents After Settings Change

V. FAST BUS TRIP SCHEME MISOPERATES DUE TO IMPROPER DC CONTROL WIRING

There are numerous ways to provide sensitive and high-speed protection of a distribution bus. One common scheme involves including the distribution bus within the transformer

differential relay zone of protection. CTs are required on the load side of each feeder breaker, and these are often paralleled due to the limited number of winding inputs available on the transformer differential relay. This scheme does not differentiate by way of trip targets a bus fault from a transformer fault. Also, care must be taken to not overload the winding input on the relay for load conditions when paralleling many CT inputs.

An alternative solution involves installing a dedicated bus differential relay. This relay provides clear indication of fault location by way of dedicated bus trip targets. This solution requires CTs from each feeder as well as the dedicated bus relay.

A fast bus trip scheme is yet another alternative for providing distribution bus protection [3]. This scheme is also commonly referred to as a zone interlocking or blocking scheme. A fast bus trip scheme may be implemented with physical wiring in the dc control circuits or through the use of high-speed, peer-to-peer communications (serial, fiber optics, or Ethernet). While a fast bus trip scheme is slightly slower than the other methods, it does not require an additional relay or dedicated CTs.

Fig. 10 shows a fast bus trip scheme implemented with an existing main breaker and feeder relay. For a fault at F2 on the feeder, the feeder relay should trip. The feeder relay closes an output contact, which energizes a blocking input on the main breaker relay. The blocking signal prevents the main breaker relay from tripping at high speed. Only one feeder is shown for simplicity; additional feeders would have similar blocking contacts wired in parallel with the feeder shown.

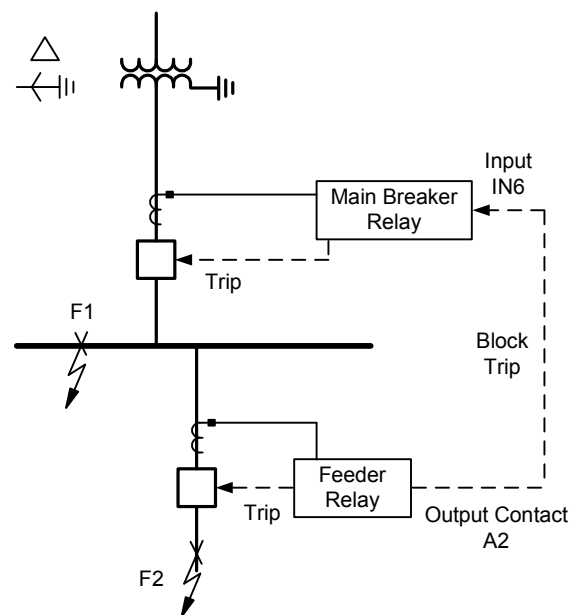

Fig. 10. Fast Bus Trip Scheme

For a fault at F1 on the bus, the feeder relay should not operate (assuming this is a radial system). The main breaker relay is allowed to trip at high speed without the presence of a blocking input. A short coordination delay (3 to 5 cycles) is used to ensure security for feeder faults.

Directional overcurrent elements can be used in the feeder relay if the system is not radial. There need not be a main breaker installed to implement this scheme. Some fast bus trip schemes use overcurrent elements integrated within the low-side winding input of the transformer differential relay for the same purpose. To provide backup protection for a failed feeder breaker, the scheme typically allows inverse-time elements to operate regardless of the blocking signal (or the blocking signal is released by the relay associated with the failed breaker).

Fig. 11 shows an event report captured by a feeder relay when a fault occurred on the feeder. The fault started as a phase-to-phase fault but transitioned within five cycles to a phase-to-phase-to-ground fault. The event data show that a phase time-overcurrent element (51P) asserted, started timing to trip, and simultaneously closed the blocking output contact (OUT2) to prevent the main breaker relay from operating.

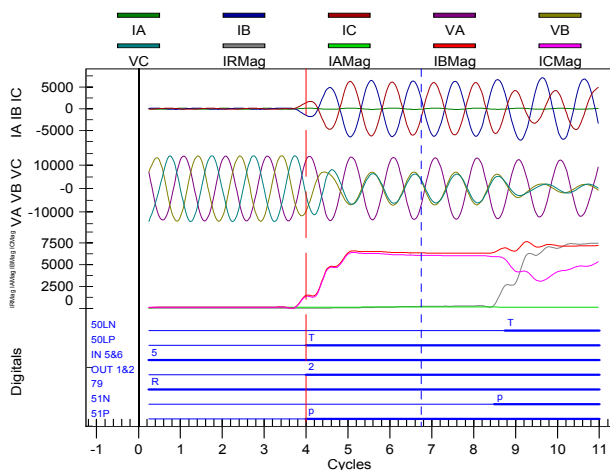

Fig. 11. Feeder Breaker Relay Response to Fault at Location F2

Fig. 12 shows an event report captured by the main breaker relay for the same fault. At the beginning of the fault, Input 2 (IN2) asserted. As the fault transitioned, the bus protection elements (50HP and 50HN) asserted and began timing to trip. After a short three-cycle coordination delay, the 50HP element tripped the bus main breaker. This de-energized the faulted feeder in addition to several unfaulted feeders.

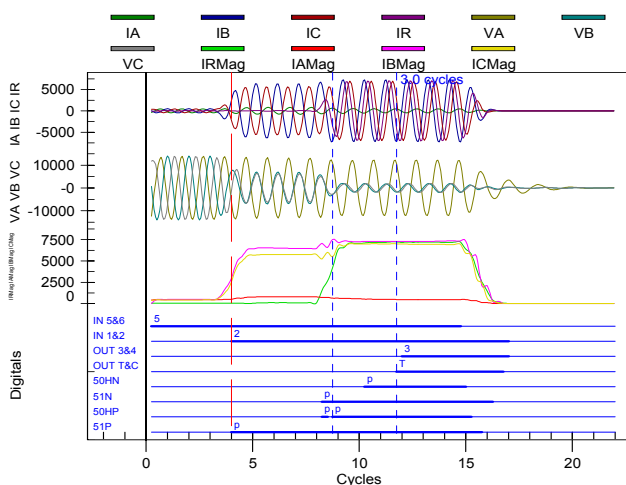

Fig. 12. Main Breaker Relay Response to a Fault at Location F2

Fig. 13 is a representation of the trip logic settings in the main breaker relay. The block signal, according to settings, was expected to be received on Input 6, IN6. Recall that the event data from Fig. 12 show that the blocking signal was actually received on Input 2, IN2.

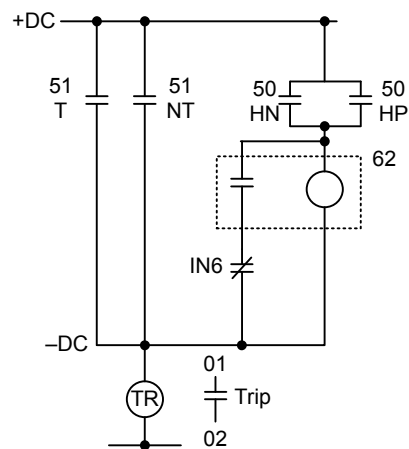

Fig. 13. Main Breaker Relay Trip Logic

We can say with confidence that this scheme was not fully tested during initial commissioning because this wiring error would have been found. We suspect that the lack of a logic diagram such as Fig. 13 contributed to the testing failure. We also suspect that the location of the feeder relays in the switchyard breaker cabinets and the bus main breaker relay inside the substation control building contributed to the testing failure. A valid test would have involved thoroughly testing the feeder relay and proving its output contacts worked. Then a jumper should have been applied to the blocking contact at the feeder relay, while performing current injection tests at the main breaker relay. If this had been performed, the improper tripping of the main breaker would have been observed. The wiring error would have been found before it led to a bus outage. A detailed logic diagram would have assisted in recognizing the need for, and the development of, a test procedure [4].

VI. RESIDUAL GROUND ELEMENT FOR A MOTOR MISOPERATES DUE TO CT SATURATION

A microprocessor overcurrent relay tripped while starting a 15,000 HP motor. The element that tripped was a residual (ground) overcurrent element, 50G, which operates from the sum of the three measured phase currents. The CT ratio was 800:5. In addition, the same relay is connected to a 50:5 zero-sequence (toroidal or flux-balancing) CT, which measures zero-sequence current. A ground overcurrent element, 50N, that operates from this measured zero-sequence current is available but did not operate. In the original settings, both elements, 50G and 50N, were enabled to trip. The original 50G setting was set to 0.5 amperes secondary with a six-cycle delay, four times less sensitive (higher) than the 50N setting.

In Fig. 14, raw or unfiltered data from the relay is shown. The 310 ground current calculated from the three-phase CTs is shown as IG. The measured ground current from the zero-

sequence CT is shown as IN. Phase current magnitude, asymmetry, unbalance, and the resulting CT saturation during the motor start are the causes of false IG residual current. Notice that IN remains at zero.

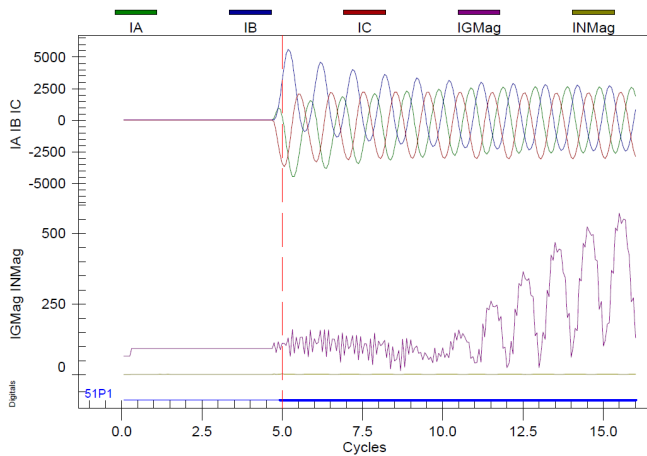

Fig. 14. Raw Microprocessor Relay Data from 15,000 HP Motor Start

Fig. 15 shows the filtered currents from the same motor start. A 50G element, operating from the sum of the three-phase CTs, should be set no more sensitive than 1.5 amperes secondary [5]. From event data collected during motor starts, we observed that the CT unbalance subsides after about 30 cycles, or 0.5 seconds. Based on this, a 50G pickup of 2.0 amperes secondary with a time delay of 30 cycles was implemented, taking into account observed starting unbalance and observed starting times.

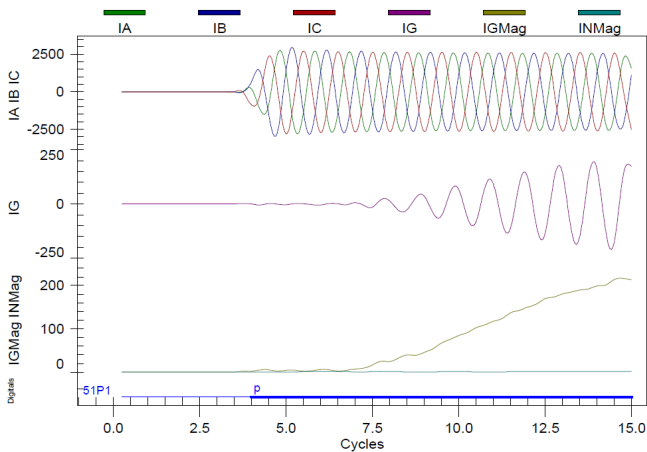

Fig. 15. Filtered Microprocessor Relay Data from 15,000 HP Motor Start

Reference [6] states that the asymmetrical current, which is determined by taking the starting current and multiplying by the dc offset, will be maximum when the voltage is near a zero crossing when the motor is started. It further states that the CTs will saturate due to the asymmetrical current, composed of a dc component, and that the saturation will decrease the CT ability to reflect the primary current accurately. It should be noted that an electromechanical relay, set equally as sensitive, should respond the same to this phenomena.

No IN neutral current is expected to be seen during a motor start. That current is supplied from a zero-sequence CT (a toroidal CT encircling the three-phase lead conductors). Saturation is avoided in the zero-sequence CT since the sensor responds only to the magnetic flux caused by unbalance in the sum of the three primary phase currents.

When the current is high during starting, small errors are magnified. With residual elements set with extremely sensitive pickup and short-delay settings, problems can occur. Perhaps there was confusion on the naming conventions used by the manufacturers versus what was familiar to the protection engineer (50G versus 50N). However, it is more likely that the engineer did not fully understand the subtle differences in operation of these elements and their driving CTs. With good intentions and because the microprocessor relay includes both a 50G (sum of phase currents) and 50N (measured 3I0) element, each was included by the engineer in the trip logic. This event reminds us to take care in understanding elements before enabling them.

VII. RESIDUAL GROUND ELEMENT MISOPERATES DUE TO INCORRECT CT POLARITY

Fig. 16 is a one-line representation of a new substation nearing completion. Commissioning and final checkout testing were underway. The 47 MVA transformer on the right had been energized from the high side (low side open) for several weeks. The job at hand was to energize one of the feeder circuits (shown at the far left), picking up a small amount of load, and perform in-service commissioning tests for the transformer differential relay.

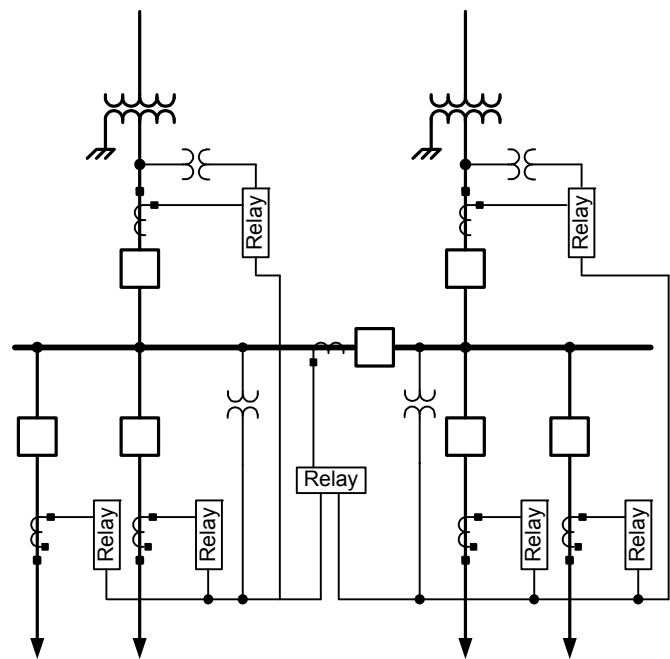

Fig. 16. One-Line Diagram of New Substation

When the feeder breaker was closed, the bus-tie breaker tripped unexpectedly. Nothing else in the substation tripped. The event report data collected from the bus-tie breaker are shown in Fig. 17. The trip was generated by a ground overcurrent element, 50G1, after a four-cycle fast bus trip scheme delay. In this design, the blocking signals for the fast bus trip scheme are received via fiber-optic communications.

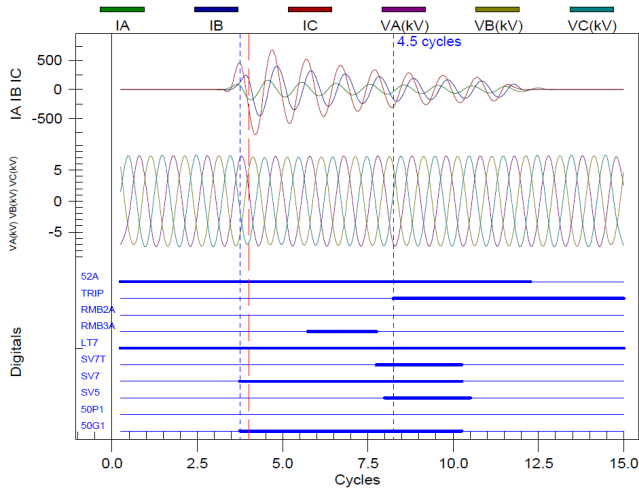

Fig. 17. Bus-Tie Breaker Relay Trips During Commissioning Tests

The feeder breaker relay did generate event data when it was closed, but it did not trip. From the data shown in Fig. 18, we verified that load current was picked up and that a blocking signal was sent for 2.5 cycles to the bus-tie breaker relay. Phase currents substantially lagged their respective phase voltages. Raw or unfiltered data show that the current was largely harmonic inrush, picking up downstream transformer loads. The ground current (calculated from the sum of the three-phase currents) was relatively low compared to the maximum phase current in the feeder.

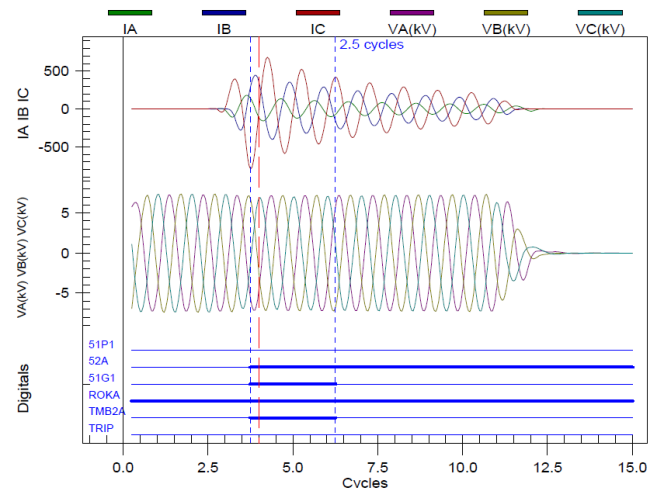

Fig. 18. Feeder Breaker Relay Data During Commissioning Tests

Notice that the ground element in the bus-tie breaker relay was picked up for longer than the ground element in the feeder breaker relay. This immediately drew attention, because the tie

breaker relay's ground element is set less sensitively (higher) than that of the feeder relay. When comparing current magnitudes between the feeder and tie relays, the phase currents match well, but the ground current is significantly higher in the tie relay.

When we look at the bus-tie relay's phasor data in Fig. 19, we notice first that the phase angles of IA and IB are 180 degrees out of phase with those recorded by the feeder relay. That is expected, in this case, due to the opposite polarity of the CTs for these relays. However, the C-phase polarity in the feeder and the bus-tie breaker relay match, indicating that we have a CT polarity problem in the bus-tie relay circuit.

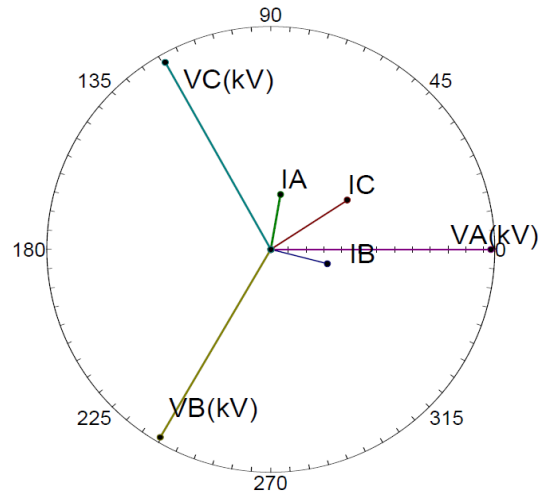

Fig. 19. Bus-Tie Breaker Relay Phasor Data During Commissioning Tests

With the aid of relay event report data, root cause was determined within just a few minutes. Confident in the determination, the commissioning engineers pressed a pushbutton on the bus-tie relay faceplate labeled "GROUND ENABLE," disabling the ground overcurrent trip (or so it was thought). The bus-tie breaker was closed, and service was restored to the load without further incident.

Days later, during post-event analysis, it was noticed that the relay pushbutton was not in any way programmed to supervise the ground fast bus trip. The 50G1 was the only ground element enabled in the bus-tie relay, and the ground enable pushbutton and associated latching logic were not programmed to supervise it. On the second close, we were just lucky that the inrush and unbalance current did not last long enough to trip the fast bus scheme.

It was recommended that the pushbutton be changed to do what was labeled, that is, supervise ground overcurrent trips. This error speaks again to a lack of scheme testing and a lack of documentation of all parts and pieces of standard logic settings.

The photograph of the relay terminal block wiring, shown in Fig. 20, confirmed that the intent of engineering drawings and wire labels was correct. The wires for C-phase current were rolled at the panel shop during panel construction, and wiring tests did not find the error there.

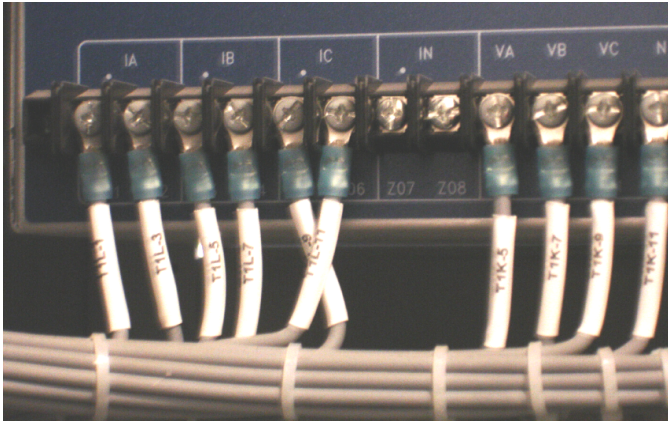

Fig. 20. CT Polarity Wiring Problem Found and Fixed

Interestingly, the panels underwent a second round of testing at a drop-in control building manufacturer. The process of testing wiring was this: currents of 1 amperes, 2 amperes, and 3 amperes were injected from a test set into Ia, Ib, and Ic terminal block positions, respectively. All currents were injected at phase angle zero degrees. The current magnitudes were then read from a panel-mounted HMI (human-machine interface) screen, confirming that no phases were crossed. However, this test did not check for incorrect polarity. A balanced three-phase test was added to the standard test routine based on this lesson learned.

Recall that the purpose of this exercise was to commission the transformer differential relay. The data recorded by the transformer differential relay during the first close (and trip) operation are shown in Fig. 21. The differential relay did not trip, but event capture was triggered by the assertion of a harmonic restraint element, 87BL. However, one thing is clear; there are no low-side currents measured at the relay. In fact, the CTs on either side of the low-side main breaker were found to be shorted. This again speaks to the need for better commissioning tests, including primary injection tests, for checking out new transformer differential installations [7].

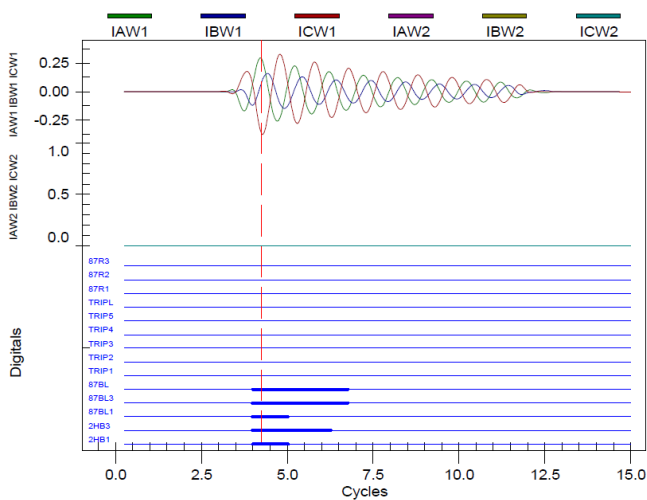

Fig. 21. CTs Shorted on Differential Relay Low-Side Winding

VIII. RESTRICTED EARTH FAULT SCHEME MISOPERATES DUE TO INCORRECT CT POLARITY

Restricted earth fault (REF) protection or zero-sequence current differential protection is beneficial in transformer applications and is gaining popularity because of its inclusion, at no additional cost, in microprocessor transformer relays. REF protection offers a significant improvement in sensitivity over traditional differential protection.

Ground current in the transformer neutral is compared to zero-sequence current at the terminals of grounded-wye transformer windings to determine if a fault is internal to the transformer. The single-phase CT connected to the X0 bushing of a delta-wye transformer supplies the reference current and is connected such that the CT polarity is away from the transformer and nearest to ground. The terminal zero-sequence current is derived from the sum of phase CT currents, and polarity is connected away from the transformer windings. Therefore, for an internal ground fault, the neutral and terminal zero-sequence currents are expected to be nearly in phase. For an external ground fault, the neutral and terminal zero-sequence currents are expected to be out of phase. The predictability of the current phase angles, as with any differential or directional scheme, is critical to successful performance [8].

The REF installation shown in Fig. 22 tripped when load was picked up by closing a feeder tie switch. This meant that a wiring or setting problem might exist, or the transformer really had an internal ground fault.

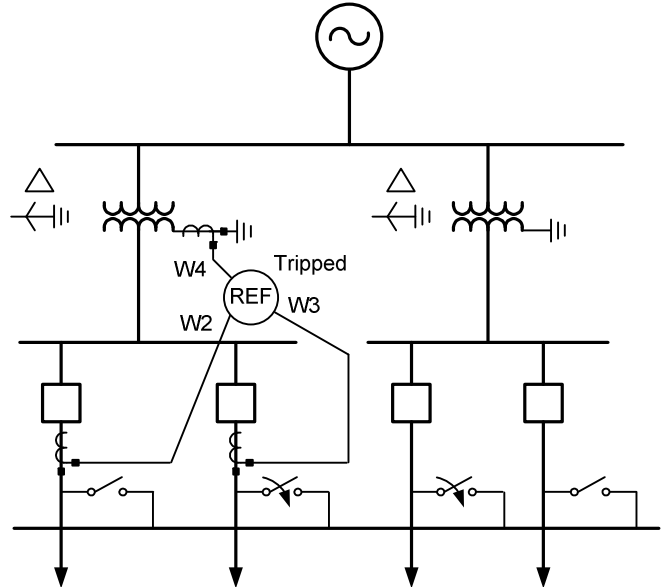

Fig. 22. Simplified One-Line Diagram of REF Operation

Fig. 23 shows the high-side and low-side phase currents from the event data recorded by the relay. For an ANSI standard transformer with wye CTs, we expect the low-side CT secondary currents (W2 and W3) to lead the high-side CT secondary currents (W1) by 150 degrees. Fig. 23 matches expectations, so the terminal CTs used by the REF element are correct.

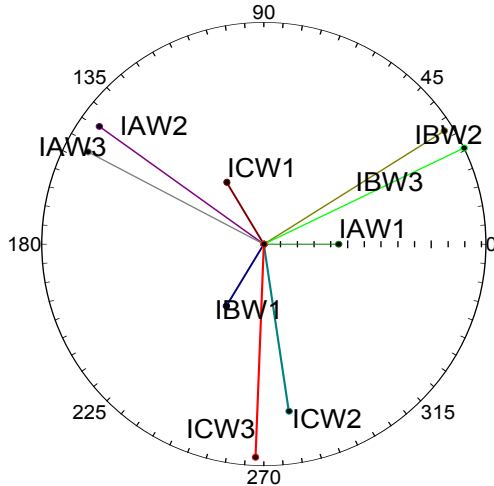

Fig. 23. Winding Currents From Differential Relay Match Expectations

The X0 bushing CT, however, needs to be checked. The zero-sequence reference current (IW40) and terminal currents (IW20 + IW30) are nearly in phase (Fig. 24). This indicates that either the X0 CT is connected with incorrect polarity or an internal ground fault exists.

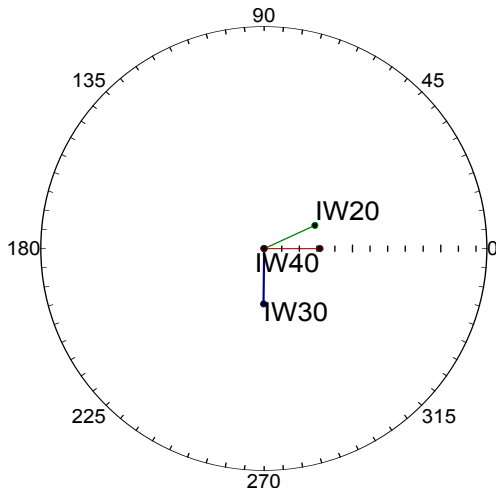

Fig. 24. REF Currents Do Not Match Expectations

Consider the zero-sequence phasors shown in Fig. 25. These were recorded during normal load from the parallel transformer bank. The zero-sequence current is standing load unbalance on the distribution system and should therefore look like an external zero-sequence condition. It does; the reference (IW40) is nearly out of phase with the terminal currents (IW20 + IW30).

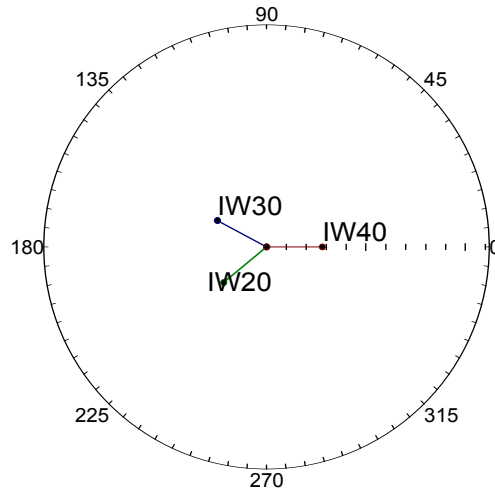

Fig. 25. REF Currents in Parallel Transformer During Normal Load

We now must determine if the trip was due to an actual internal ground fault. During the trip, the two transformers were paralleled via the transfer bus. Therefore, W3 would have been a source of ground fault current for an internal winding fault. However, during another event report trigger, taken two weeks later, the two buses were not connected. In other words, W3 was a radial load and not a zero-sequence source, at that time. The zero-sequence phasors look identical to those in Fig. 24. Therefore, we can say with confidence that the reference CT, the X0 bushing single-phase CT, is connected with opposite (and incorrect) polarity. This was the root cause of the misoperation.

IX. CONCLUSIONS

All of the examples presented show situations where basic rules of protection were either not understood or where the impact of changing system conditions was not considered. Lessons to be learned from these examples include:

1. When applying any unfamiliar element, the protection engineer must take the time to understand how the element operates and the relevant setting criteria. This is particularly an issue with today's more powerful relays, as they allow protection elements to be used in new ways for little or no incremental cost.
2. The protection engineer needs to understand how the settings of microprocessor relays affect their operation. The engineer must realize that basic protection principles (such as the requirement to remove zero-sequence components in differential protection) have not changed, but the ways that these principles are treated may have.
3. Once familiar with the setting criteria for a particular element, the protection engineer must consider how changing system conditions might affect operation.
4. Enough emphasis cannot be placed on the importance of documenting settings and programmable logic, developing thorough commissioning checklists, and performing complete scheme tests in order to find errors before systems are placed in service.

X. REFERENCES

- [1] *IEEE Guide for Protective Relay Applications to Power Transformers*, IEEE Standard C37.91-2000, March 2000.
- [2] J. Roberts, S. E. Zocholl, and G. Benmouyal, "Selecting CTs to Optimize Relay Performance," proceedings of the 23rd Annual Western Protective Relay Conference, Spokane, WA, 1996.
- [3] M. Feltis, "Faster Distribution Bus Tripping With the SEL-251/251C Relays," SEL Application Guide (AG92-03), 1992.
Available: <http://www.selinc.com/aglist.htm>.
- [4] J. Young and D. Haas, "The Importance of Relay and Programmable Logic Documentation," proceedings of the DistribuTECH Conference and Exhibition, Tampa, FL, January 2008.
- [5] S. E. Zocholl, *AC Motor Protection*, Schweitzer Engineering Laboratories, Inc., 2004.
- [6] B. H. Moisey, *Concepts of Motor Protection*, Australia: B. H. Moisey, 1997.
- [7] K. Zimmerman, "Commissioning of Protective Relay Systems," proceedings of the 34th Annual Western Protective Relay Conference, Spokane, WA, October 2007.
- [8] N. Fischer, D. Haas, and D. Costello, "Analysis of an Autotransformer Restricted Earth Fault Application," proceedings of the 34th Annual Western Protective Relay Conference, Spokane, WA, October 2007.

XI. BIOGRAPHIES

Lee Underwood received a BSEE from the University of Virginia in Charlottesville in 1990. From 1990 to 1996, he worked as a design and systems engineer for Duke Power Oconee Nuclear Station, with emphasis on dc power systems, medium- and low-voltage switchgear, and protective relaying. In 1996, he joined Duke/Fluor-Daniel and participated in the design and construction of electrical systems for coal-fired power plants. Lee joined Schweitzer Engineering Laboratories, Inc. as a field application engineer in 2004. He is currently a lead power engineer in research and development. Lee is a member of the IEEE Power Engineering Society and a registered professional engineer.

David Costello graduated from Texas A&M University in 1991 with a BSEE. He worked as a system protection engineer at Central Power and Light and Central and Southwest Services in Texas and Oklahoma. He has served on the ERCOT System Protection Task Force. In 1996, David joined Schweitzer Engineering Laboratories, Inc., where he has served as a field application engineer and regional service manager. He presently holds the title of senior application engineer and works in Boerne, Texas. He is a senior member of IEEE and a member of the planning committee for the Conference for Protective Relay Engineers at Texas A&M University.