

**A NEW DIGITAL TRANSMISSION LINE
CURRENT DIFFERENTIAL RELAY SYSTEM -
CONCEPTS AND TEST RESULTS**

by

Leonard J. Ernst
William C. Fleck
Walter L. Hinman

Dowty Control Technologies, Boonton, New Jersey

Presented to the
19th Annual

WESTERN PROTECTIVE RELAY CONFERENCE

Spokane, Washington
October 20-22, 1992

A New Digital Transmission Line Current Differential Relay System - Concepts and Test Results

by

Leonard J. Ernst, William C. Fleck, Walter L. Hinman
Dowty Control Technologies, Boonton, New Jersey

INTRODUCTION

Current differential and distance-based relaying are two of the most popular forms of transmission line pilot protection. As discussed in Reference 1, current differential relaying offers many advantages such as:

1. Short line applications.
2. Series capacitor applications.
3. Outfeed conditions.
4. Blocking during swing conditions.
5. Unaffected by loss of potential.

Despite these advantages, current differential relaying is less popular than the distance based pilot schemes. (See Reference 2). The infrequent use of current differential relaying is apparently the result of telecommunications problems and constraints as described below:

1. Precise channel delay compensation is required.
2. A high-capacity channel is required, particularly if each phase is protected separately.
3. Protection is lost when the channel fails or is impaired.

An alternative form of current differential relaying called "charge comparison" has recently been developed by Dowty Control Technologies. Charge comparison overcomes the three telecommunications problems listed above, making this form of protection very attractive. This paper describes the relaying and communications concepts of charge comparison and reports laboratory and field test results to date.

HOW CHARGE COMPARISON WORKS

Figure 1 shows how charge comparison works. The current wave of each phase and residual is sampled every 0.5 ms. The half-cycle area under each wave is measured by integrating current samples between zero-crossings. For each phase and ground, the resulting ampere-second area (or coulombs of charge) is converted to an equivalent rms current value and stored in memory, along with polarity and start/finish time-tags. This storage operation occurs only if the magnitude exceeds 0.5 ampere rms equivalent and the half-cycle pulse width is equal to 6 ms or more.

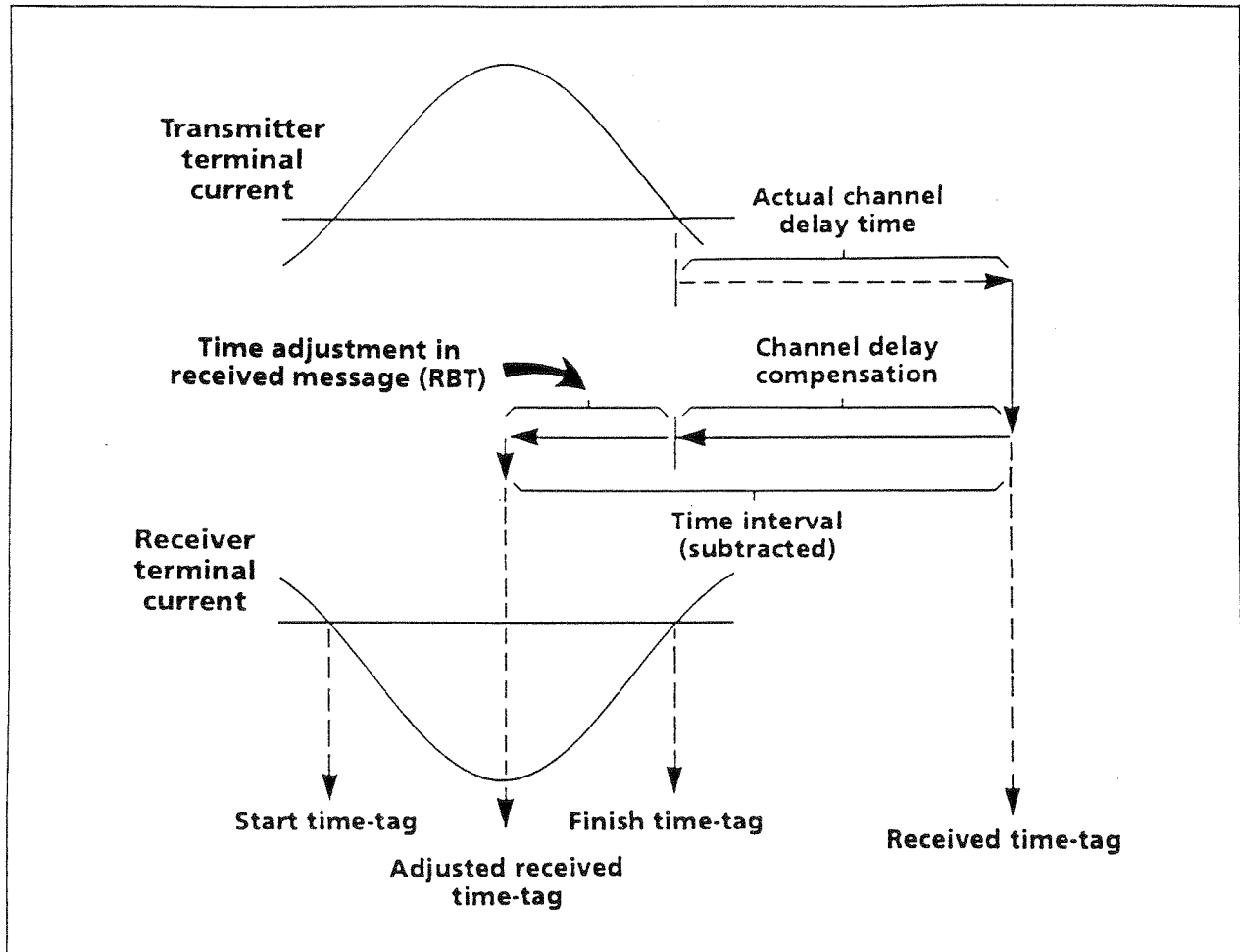

Figure 1. Operation of charge comparison during an external fault

NOTE

Current magnitude is measured in terms of ampere-seconds (coulombs). However, all values are converted to amperes rms equivalent, based on a perfect 60-Hz sine wave (without offset). Current values in this paper are secondary currents, based on current transformers rated for 5 amperes.

The three positive phase and the negative 3I0 current magnitudes are transmitted to the other terminal, along with phase identification and some timing information. The timing information is related to half-cycle duration and queuing time (if any) at the transmitting terminal. When the remote terminal receives the message, it is immediately assigned a received time-tag. A time interval is then subtracted from the received time-tag. This interval represents the channel delay compensation and the timing information contained in the received message. (The delay compensation value does not have to be precisely equal to the actual channel delay time.) This adjusted received time-tag (after subtraction) is then compared with the local start and finish time-tags stored at the remote terminal. (See Figure 1.)

For a given half-cycle stored in memory, a "nest" is achieved when the adjusted received time-tag is greater than the local start time-tag, and less than the local finish time-tag. If the channel delay compensation is precisely equal to the actual channel delay time, a "perfect nest" is achieved. The adjusted received time-tag will fall half-way between the local start and finish time-tags. For imprecise channel delay compensation (up to ± 4 ms deviation), a successful nesting is still achieved and the correct local half-cycle is identified.

When the nesting operation is completed, the local and remote current magnitudes are added to create the scalar sum and arithmetic sum. The scalar sum is the sum of all absolute magnitudes, and the arithmetic sum is the absolute magnitude of the sum of the signed magnitudes. The scalar sum becomes the effective restraint quantity, and the arithmetic sum becomes the effective operate quantity. This is illustrated by the bias characteristic shown in Figure 2.

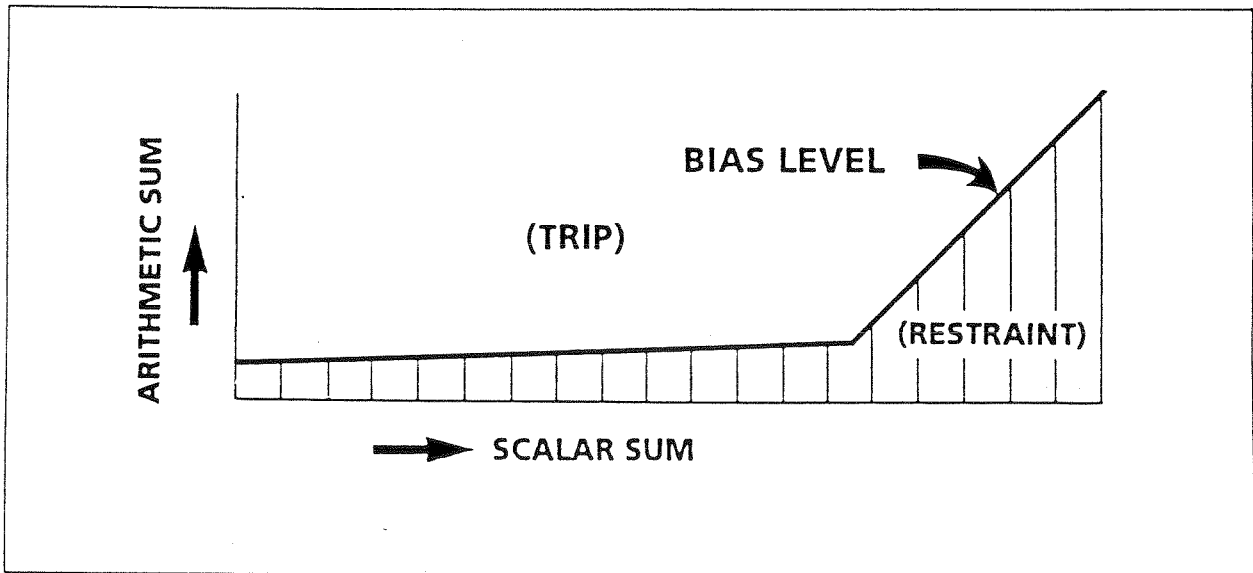

Figure 2. Bias characteristic of charge comparison

The bias level is an operate threshold that provides security in the presence of spurious operate currents. These currents are caused by many factors, including line charging current, current transformer mismatch, and analog-to-digital conversion quantizing errors. Figure 2 shows that the bias level rises sharply after the scalar sum reaches 20 amperes. This provides security for unequal CT saturation during high current external faults. At lower currents, the bias level has a slight upward slope. This takes care of minor non-communications-related errors that increase with current level, such as CT ratio errors.

When plotted on a polar diagram, the operating characteristic of charge comparison has the "rainbow" shape shown in Figure 3. Referring to Figure 1, if the adjusted received time-tag nests with a local negative half-cycle, this is equivalent to the upper half of Figure 3. If the adjusted received time-tag nests with a local positive half-cycle, the arithmetic sum and scalar sum are equal to each other. This describes a 45-degree line on the bias characteristic, well above the bias threshold for all current values. This is equivalent to the lower half of Figure 3.

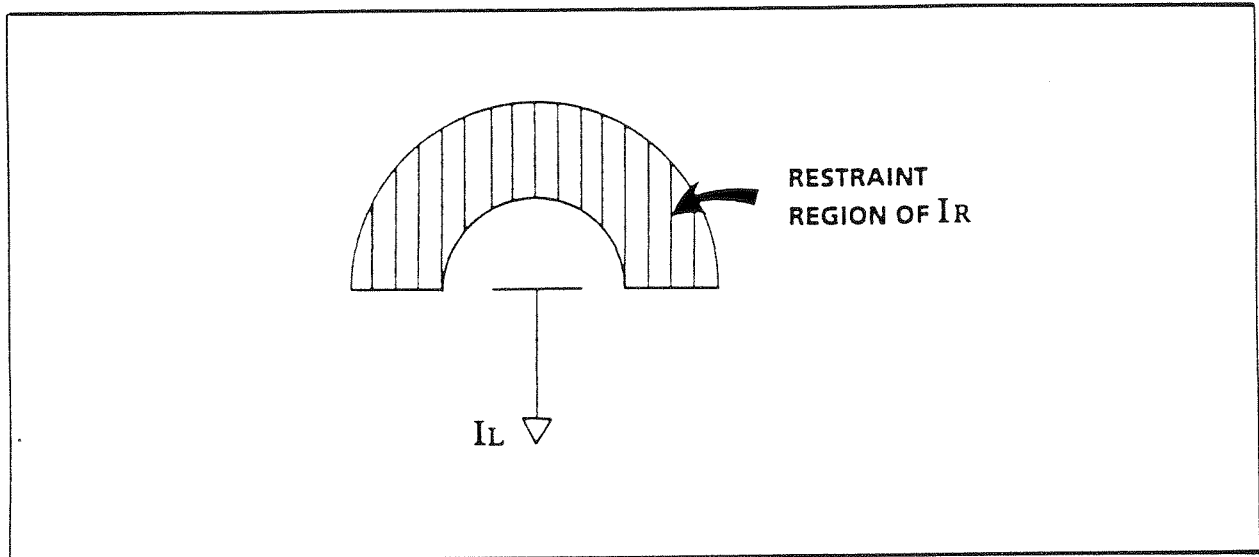

Figure 3. Rainbow polar diagram characteristic

Charge comparison is based on the principle of conservation of charge at a node. This is the principle from which Kirchhoff's Current Law (the theoretical basis of current differential relaying) is derived. The basic operation of charge comparison has been patented. (See Reference 3). The relay/communications system using this concept is the Dowty Control Technologies RFL 9300.

ELIMINATING THE NEED FOR PRECISE CHANNEL DELAY

Although charge comparison is very tolerant of incorrect channel delay compensation, accurate compensation during nominal conditions is desirable. To accommodate changes in the communications channel, the compensation automatically changes as the channel delay varies. Accurate nominal compensation allows the system to operate correctly during the interval after a sudden change in channel delay time and before a new measurement can be made and the compensation value corrected.

Charge comparison uses two channel delay measurement techniques: ping-pong (round-trip delay measurement) and DML (delay measurement based on load current).

PING-PONG MEASUREMENT

About once a second, each relay transmits a PPI (Ping-Pong Initiate) message and starts a clock. As soon as PPI is received, the remote relay puts a PPR (Ping-Pong Response) message in its transmitter queue. If there is nothing of higher priority waiting in the queue, then PPR will be transmitted as the next message. The remote station keeps track of how long PPR has to wait, and this queuing time is included in the PPR message. The queuing time is then subtracted from the total clock time at the initiating terminal to get actual round-trip transit time. (See Figure 4.)

Initially, the charge comparison system assumes half of the round-trip ping-pong measurement for "ACTUAL CHANNEL DELAY TIME" and "CHANNEL DELAY COMPENSATION." As shown in Figure 1, the "TIME ADJUSTMENT IN RECEIVED MESSAGE" can also be called the "RBT" (Reach-Back Timer) delay.

$$RBT_A = [(PW - 6 \text{ ms})/2] + \text{Transmitter terminal queue time} + 3 \text{ ms}$$

$$PW = \text{Transmitter terminal pulse width}$$

Therefore,

$$\text{The subtracted time interval} = RXTT - CDC - RBT_A$$

$$RXTT = \text{Received time tag}$$

$$CDC = \text{Channel delay compensation}$$

Ping-pong is also used on three-terminal lines, with a separate measurement made on each delta-connected leg (L/R, L/M and M/R in Figure 4).

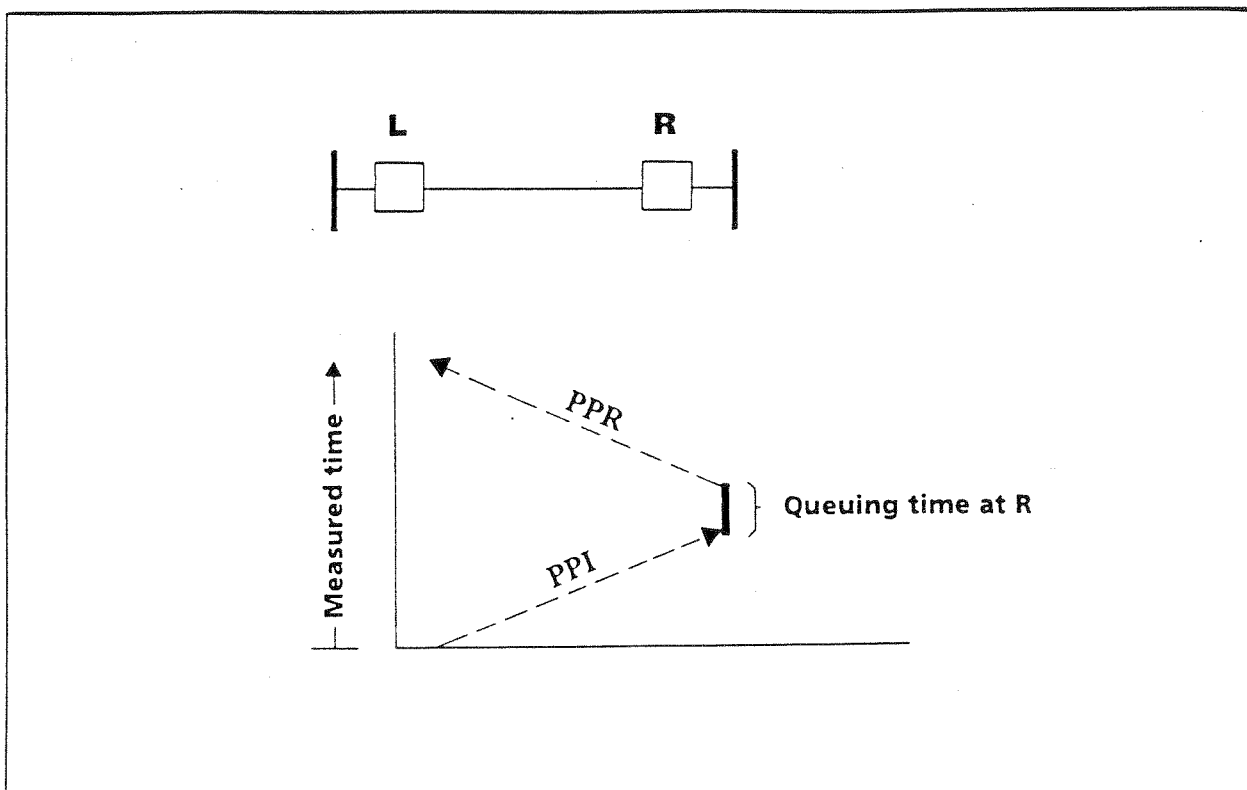

Figure 4. Ping-pong measurement

DELAY MEASUREMENT - LOAD

The ping-pong measurement provides an accurate channel delay time only if the outgoing and return channel times are the same. If these times differ significantly, then an error is introduced. The RFL 9300 incorporates a DML (Delay Measurement-Load) measurement technique that is not subject to this error.

The phase angle of small load current is influenced by line-charging current, particularly on long EHV lines. Therefore, DML calculations are only done when the system is quiescent (no active fault detectors) and load current is 2 amperes rms or greater (on a 5-ampere base). DML looks for a perfectly centered "nest" of the adjusted received time-tag within the local negative half-cycle of phase current. If the channel delay is undercompensated (Figure 5a) or overcompensated (Figure 5b), the nesting is off-center. When this happens at least three times sequentially, the receiving terminal measures this deviation and calculates a corrected CDC (channel delay compensation) value which is applied to the following equation:

$$\text{Adjusted received time tag} = \text{RXTT} - \text{CDC} - 3 \text{ ms} - \text{RBT}$$

$$\text{RXTT} = \text{Received time tag}$$

$$\text{CDC} = \text{Corrected channel delay compensation}$$

DML is used on two-terminal lines only.

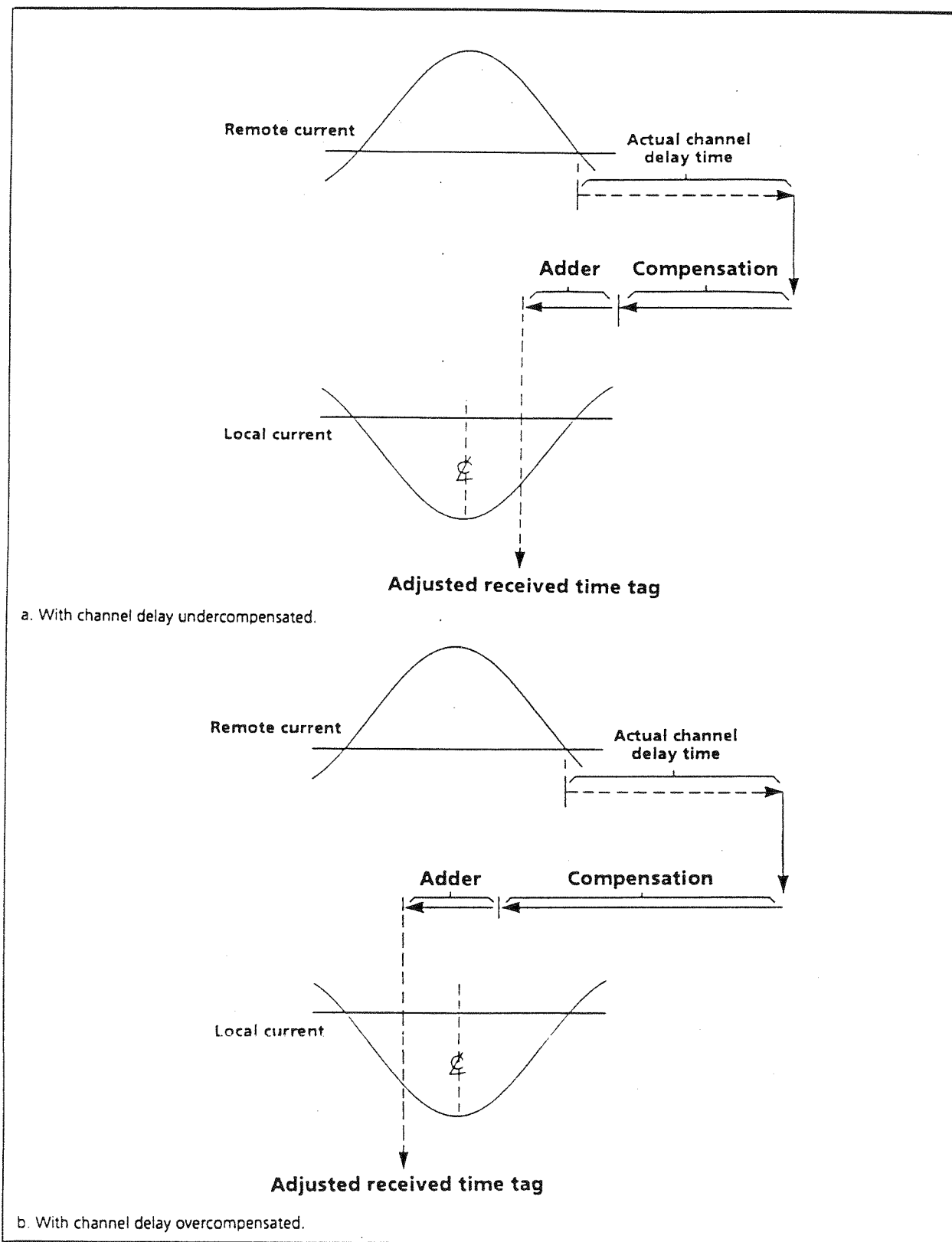

Figure 5. DML measurement

SUMMARY OF CHANNEL DELAY MEASUREMENT

Whenever the channel is working in both directions, ping-pong delay measurements are performed. This information may be used to automatically calculate the channel delay compensation. DML is used to enhance the ping-pong method of delay measurement and corrects the errors that would occur if the outgoing and return channel times are different.

The rainbow characteristic of Figure 3 illustrates how precise channel delay compensation is no longer critical. For external and internal faults, it tolerates improper channel delay compensation (up to ± 4 ms) without misoperation. The rainbow characteristic also improves the sensitivity during outfeed conditions (high-resistance ground faults with through-load and three-terminal line faults with outfeed). Figure 6 illustrates this improvement in sensitivity and security, when compared with the conventional circle characteristic.

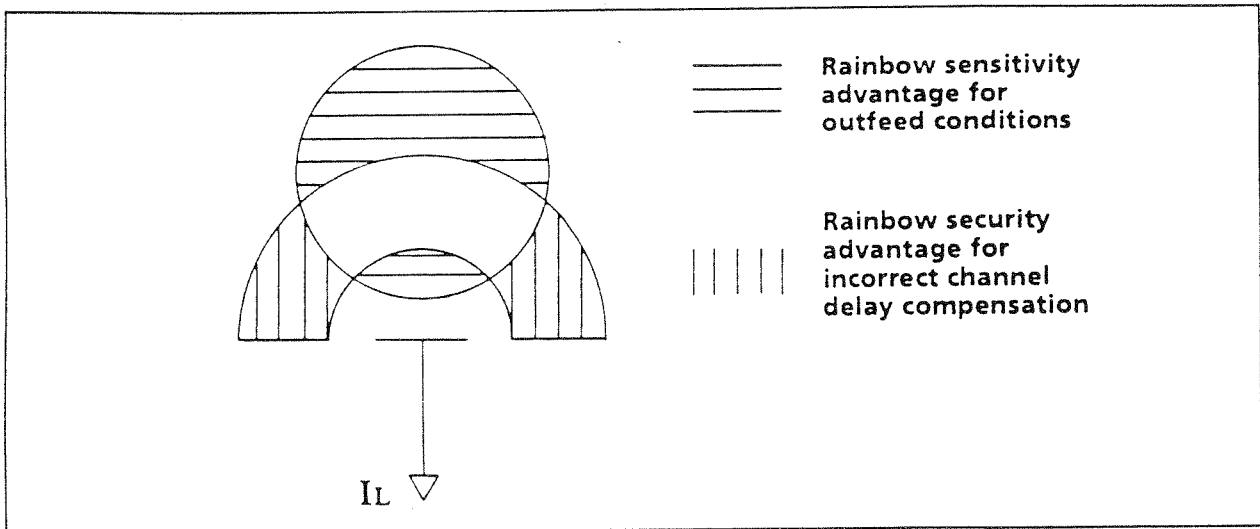

Figure 6. Rainbow characteristic vs. conventional circle characteristic

SOLVING THE HIGH-CAPACITY CHANNEL REQUIREMENT

Charge comparison requires minimal communications channel capacity, since a single message is sent once per cycle, per phase. A 7.2-Kbps modem, suitable for transmission over an analog voice circuit, provides the necessary channel throughput for charge comparison of all three phase currents and residual current. Therefore, charge comparison solves the second problem (a large communications capacity requirement). In contrast, conventional current differential schemes must replicate the entire current phasor, which requires a wide-band channel capacity for per-phase protection.

SIGNIFICANT REDUCTION IN RELAY COMMUNICATIONS THROUGHPUT

The RFL 9300 Charge Comparison Systems requires far less communication throughput than conventional per-phase current differential schemes. This is because it sends a single value representing the area of the half-cycle; traditional current differential systems must send a complete replica of the phasor of each half-cycle. In addition, only positive half-cycle information is sent for each phase, and only negative half-cycle information is sent for ground (residual).

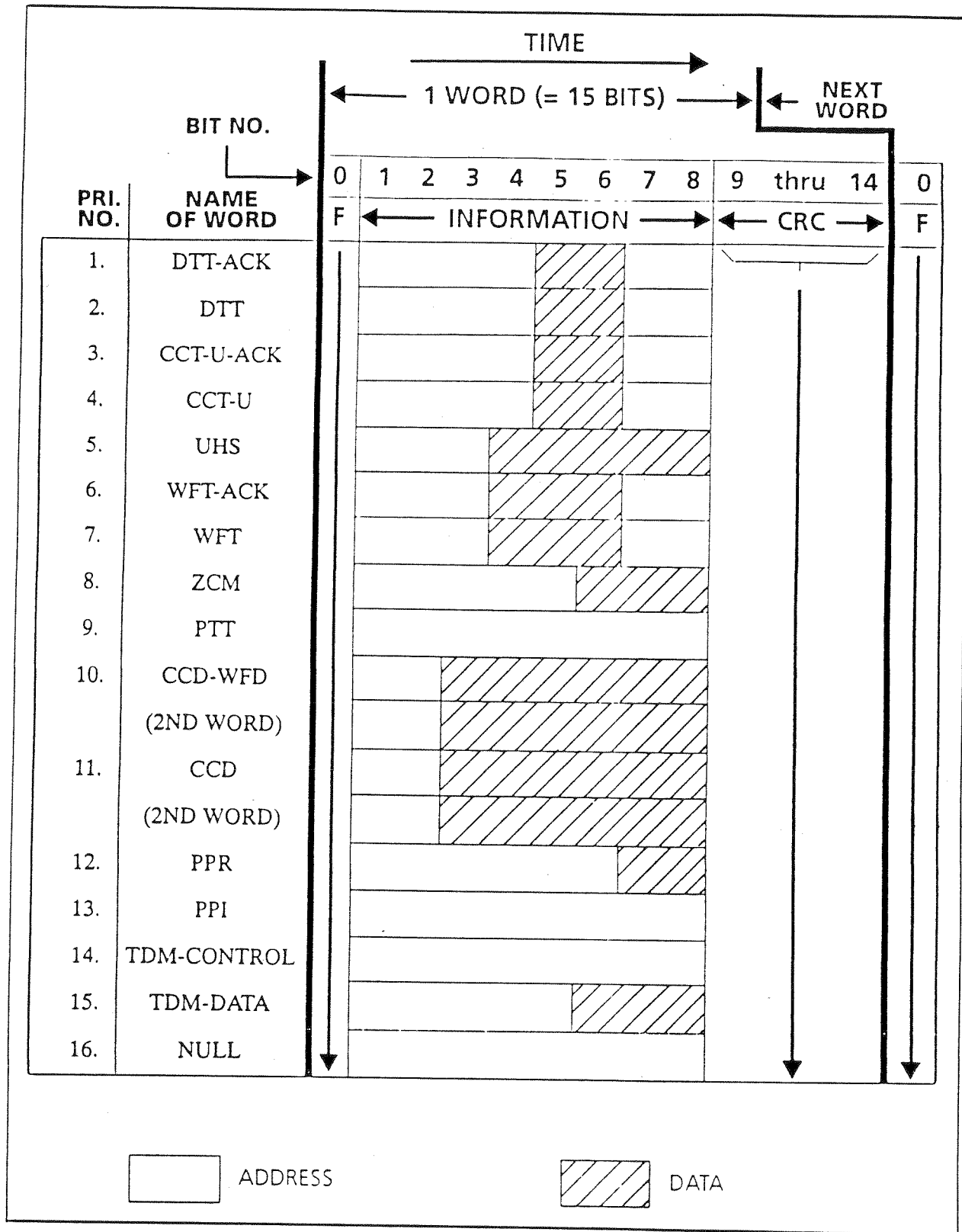

Figure 7. Charge comparison communications message structure

In addition, there are a number of messages that should be sent along with the charge comparison information; these include direct transfer trip commands, ping-pong, and zero-current messages. The RFL 9300 uses a special message structure to compress all this information into a 7200-bps channel. (See Figure 7.) This message structure features a variable ratio between address bits and data bits, and preset priorities to determine the message transmission order.

VARYING ADDRESS/DATA RATIO

This technique reduces the required channel capacity for the expected mix of traffic. Messages with heavy data content and high frequency of transmission (such as charge comparison data) are assigned a minimal number of address bits leaving a large capacity for data. At the other extreme, messages that occur infrequently or require very little data content (such as Ping-Pong Initiate) are assigned many address bits and few (if any) data bits. Figure 7 shows the varying ratio of data/address in the different messages. The shaded bits are data; unshaded bits are address.

Since some high-priority, heavy-data messages appear more often than low-priority, low-data messages, this varying address/data ratio technique is very efficient.

MESSAGE PRIORITY

Each message is placed in the transmitter queue and waits to be sent. While waiting, it competes for first place in the queue, based on priority. (See Figure 7.) Some messages are real-time, such as Charge Comparison Data, UHS, and Ping-Pong Response. These messages keep track of how long they wait in the queue; this timing information is included in the message when it is finally sent.

One important rule: regardless of the priority of a message waiting in the queue, it never interrupts a message that has started transmission. In particular, a two-word message (CCD or UHS) is never interrupted after just one word.

NOTE

CCD and CCD-WFD (Charge Comparison Data - With Fault Detector) consist of a first word and a second word, each one different. UHS (Ultra High-Speed) is always sent in two-word messages, both words the same. (This is done for enhanced dependability - the receiver operates on the receipt of a single UHS word.)

ACKNOWLEDGE PROTOCOL

The trip messages (Direct Transfer Trip, Charge Comparison Trip - Ultimate and Weak Feed Trip) are sent until acknowledged. For security, two straight trip/acknowledge messages must be received. The terminal receiving direct trips stops sending acknowledge when a different (not the original direct trip) valid word is received. This protocol gives high security and dependability, and also frees the channel quickly, so it can return to other messages. This quick release of the channel can provide useful targeting information for direct trip faults that are inside the zone of charge comparison protection. This includes line-connected shunt reactor faults.

CONTENTION AND SLIPPAGE IN THE QUEUE

At 7200 bps, severe time slippage may occasionally occur in the queue. For example, consider a heavy two-phase-to-ground fault, with load current above 12 amperes peak. For this fault, seven two-word messages (four CCD and three UHS) will attempt to transmit every cycle. This time space can only handle four two-word messages. After four or five messages have been transmitted, the slippage time will exceed the capacity of the queuing time in the CCD and UHS messages. Whenever this happens, the message is dropped from the queue.

At high bit rates, the slippage is much smaller. There may be contention, causing some slippage, but it is not cumulative as it is at 7200 bps. Each word is repeated three times (equivalent to 21 two-word messages per cycle for the case previously cited). However, the channel capacity is roughly eight times greater (equivalent to about 32 two-word messages per cycle). This means that only about two-thirds of the 56-Kbps channel's capacity is used for this maximum throughput condition.

SOLVING THE PROBLEM OF LOST PROTECTION WHEN THE CHANNEL FAILS

The third problem associated with current differential relaying of transmission lines was described as total loss of protection whenever the channel fails. Overcurrent protection can be enabled when the channel fails, but when compared to the non-pilot distance relay backup in directional comparison schemes, this is considered ineffective protection.

In order to overcome this problem, charge comparison provides protection during channel failure by several techniques, including channel redundancy and loss-of-load protection, as outlined below.

CHANNEL BACKUP, TWO-TERMINAL LINES

Loss-of-Load

This is an established technique. (See Reference 4). Loss-of-load senses the interruption of load current on the unfaulted phase(s) caused by the clearing of the remote breaker, for all internal faults except three-phase. Loss-of-load, plus a Zone 2 timer, also provides a secure and sensitive detection for open-conductor conditions that occur when the line is carrying load.

Single Channel Configuration

Figure 8 shows a typical charge comparison application using a single four-wire bi-directional communications channel (voice, wide-band digital or fiber). If the channel is lost in both directions, then a built-in overcurrent backup system is the only protection available. This consists of high-set overcurrent relays, loss-of-load, and switch-into-fault circuits. Whenever possible, the channel should be separated so that the outgoing and return channels are usually not subject to common-mode failures. With the channels separated, a channel loss in one direction will allow charge comparison clearing at one terminal and sequential clearing at the other. The sequential clearing will be caused by loss-of-load, provided there is pre-fault load current and the fault is not three-phase.

Dual-Channel Configuration

A dual-channel configuration for two-terminal lines is shown in Figure 9. This configuration is suggested for applications where an occasional channel outage (in both directions) may be expected. An example of this is microwave, where signal levels may fade because of the weather.

Dual transceivers are required at each terminal, and two separate communications links with diverse routings are used. Usually once a day, the channel in use is automatically switched to verify integrity. If the channel in use goes into a squelch (loss-of-channel) condition, switchover occurs immediately. Switchover does not occur during fault conditions, so the outgoing signal on the channel in use can be given the best chance to get through to the remote terminal.

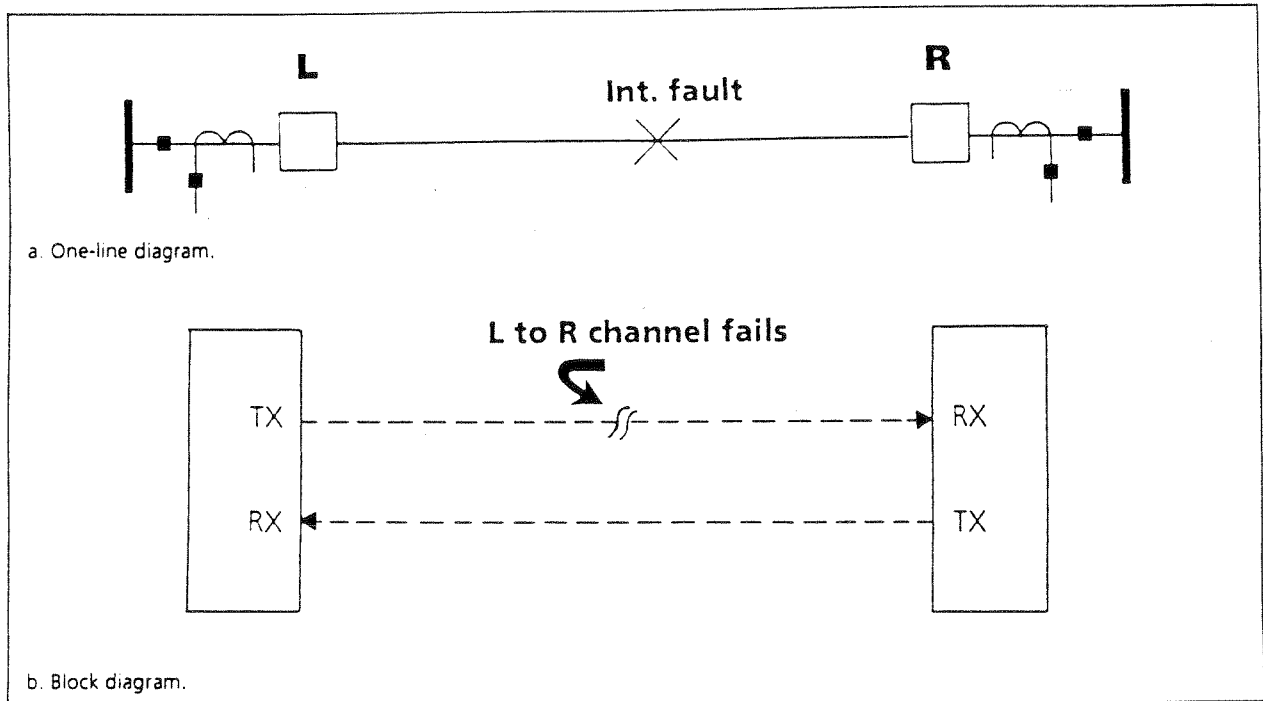

Figure 8. Two-terminal line, single-channel

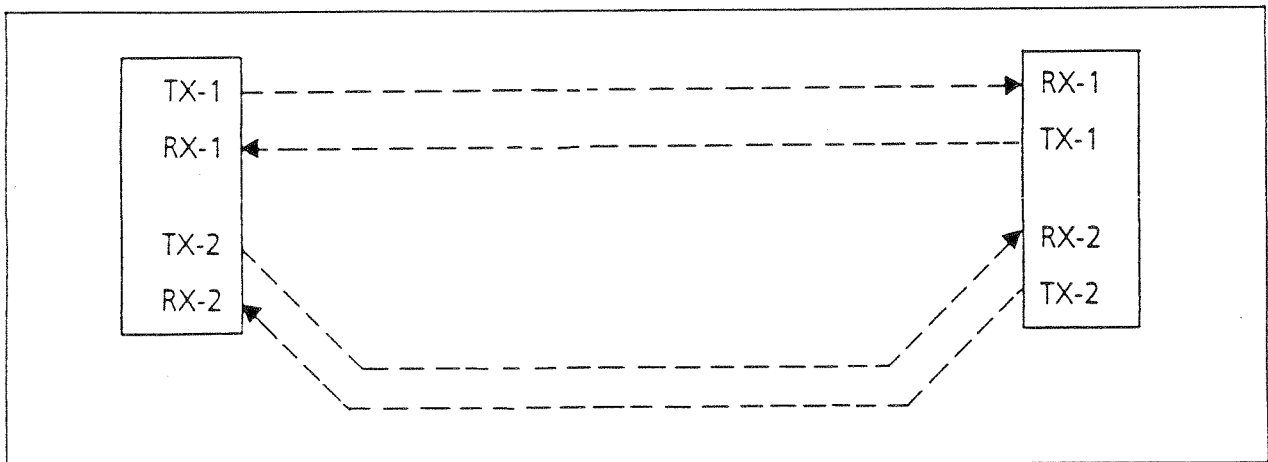

Figure 9. Two-terminal line, dual-channel with diverse channel routing

Channel Backup, Three-Terminal Lines

Charge comparison for three-terminal lines involves separate transmitters and receivers sending signals to and from both remote terminals. (See Figure 10.) If the bi-directional channel fails in one or both directions between the L and R terminals, the M terminal communications remains intact and will be able to sense all internal faults. As soon as a trip signal is developed at the M terminal, direct trip messages (without causing reclose blocking) are sent from the M terminal to both remote terminals. The three delta-connected, independent transmit/receive circuits allow each of the three bi-directional channels (L/R, L/M and M/R) to back up the other two. Of course, this is only valid if the three channels are adequately separated to prevent common-mode failures.

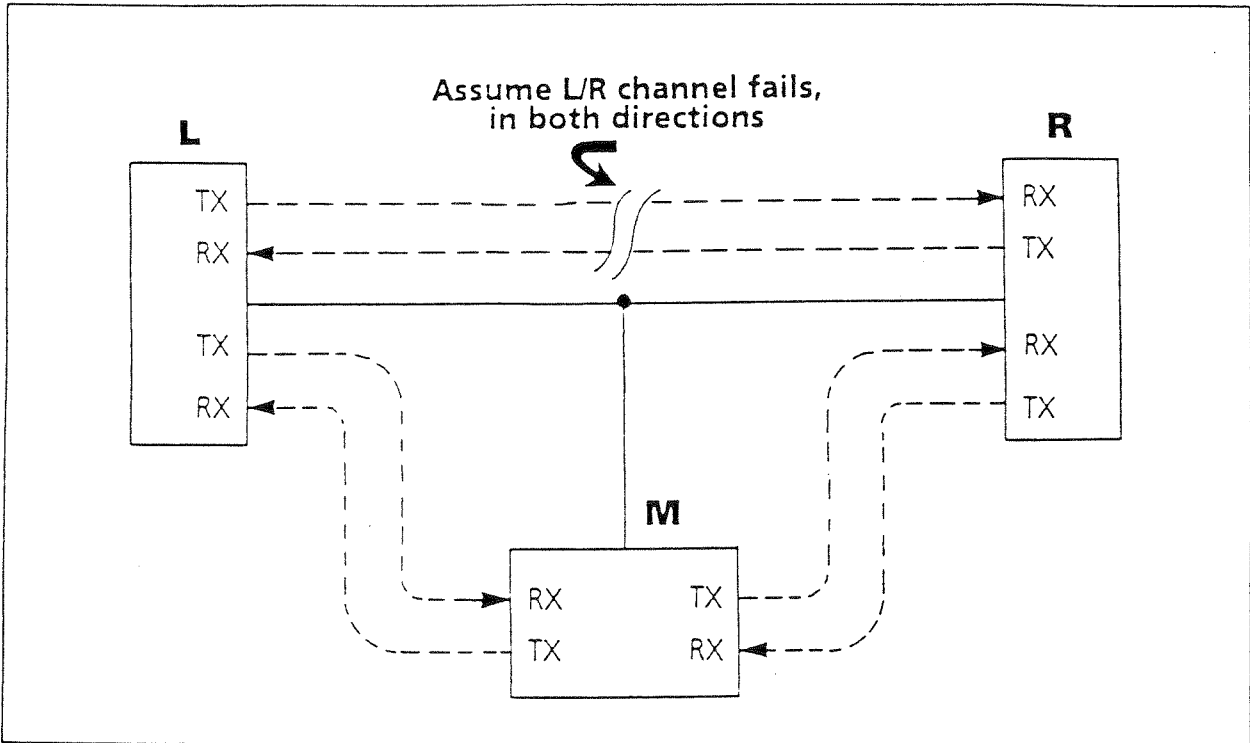

Figure 10. Channel redundancy on three-terminal line

SUMMARY OF PROTECTION DURING LOSS-OF-CHANNEL

The RFL 9300 overcomes the third disadvantage of conventional current differential schemes (failure of protection whenever the channel fails) when redundant communication circuits can be separated from each other to minimize common-mode failures. If this separation cannot be achieved, another means of protection could be used to back up the charge comparison system.

COMMUNICATIONS CHANNEL SECURITY

Redundant channels provide protection during primary channel failure by operating in a continuous parallel mode, or by being switched into service if the primary channel fails. Redundant channels improve dependability, but degrade security by providing additional opportunities for overtrip. Therefore, redundant channels can only improve system reliability if they (and the primary channels) are inherently secure in their mode of operation. Charge comparison employs several techniques to ensure this inherent security.

SECURITY MEASURES

1. Charge comparison uses a tripping philosophy instead of a blocking philosophy.
2. Each word contains CRC (Cyclical Redundancy Check) coding.
3. Fault detectors supervise all charge comparison trips. The fault detectors operate by sensing high current levels or changes in currents.
4. Direct trips require reception of two trip messages in a row.
5. Strict framing rules prevent false-framing. While receiving synchronous data, each frame bit is tested and, if corrupt, the entire word is discarded, thereby enhancing security.
6. "Scrambling" the data also improves security. Every other bit of the information portion of the word is inverted. This breaks up some patterns that could otherwise fool the CRC and framing rules.

EMPLOYING ERROR DETECTION SCHEMES

The RFL 9300 employs "CRC", a powerful error-detecting code used in digital communications. The CRC format and word length described below has established an excellent field history in teleprotection systems:

Framing	1 bit
Information	8 bits
CRC	6 bits
<hr/>	
Total Word Length	15 bits

This format catches all one-bit, two-bit and three-bit errors, per word, and most errors of four-bit and higher. Squelch (alarm and trip-blocking) occurs when many words are rejected. To come out of squelch requires a certain number of good words in a row. CRC and squelch together build a strong security shield for the communications used in the RFL 9300.

COMPARING ANALOG VOICE TO WIDEBAND DIGITAL CHANNELS

Charge comparison is intended for use over both voice-grade and wide-band channels. It would seem that two different designs would be required; one optimized for 7.2-Kbps operation, the other for 56-Kbps or 64-Kbps operation. The Dowty Control Technologies RFL 9300 uses a common design approach that accommodates simple field retrofits from voice to wide-band, whenever the wide-band channels become available.

When a wide-band channel is used (56 or 64 Kbps), each word is repeated three times and the receiver uses two-of-three voting logic. This uses the extra channel capacity to enhance both security and dependability, while keeping the design of the relay the same.

A short word length and a design that tolerates imprecise delay compensation are both required for 7.2-Kbps applications. These characteristics also greatly enhance the high bit-rate channels' performance, for the following reasons:

1. The short words (15 bits, as described earlier) have a better chance of getting through in the presence of impulse noise hits.
2. The short word length allows two-of-three voting, previously described.
3. By tolerating a large error in channel delay compensation (described later), charge comparison may be applied to switched wide-band networks. In these networks, a change in channel delay may occur when the signal path is re-routed.

TEST RESULTS

Since January of 1992, the RFL 9300 Charge Comparison System has been subjected to many thousands of laboratory tests. These tests have included simulated power system disturbances and simulated communication medium disturbances. Figures 11 through 17 illustrate some of the laboratory test results. Field testing is in progress, consisting of the modem field testing described in Reference 5 and full-system beta-site testing.

The primary test bed has been the low-level analog power system simulator in the Kettering Laboratory at Cornell University. Pre-fault currents and transient currents were captured on a multi-channel digital storage oscilloscope. These records were then played back, using arbitrary function generators and current amplifiers to energize the relay systems under test.

For most tests, a test current of 1 ampere or less was injected into a 50-turn test winding on the RFL 9300's auxiliary current transformer (ACT). The ACT is a small "active" flux cancellation transformer. When using the test winding, tests show that the ACT secondary current is identical to the current obtained when using the main winding. This comparison is based on equivalent ampere-turns.

Figure 11 shows how the RFL 9300's ACT serves as a "perfect" transformer. It even has this ability when subjected to repeated tests with maximum dc offset in the same direction, and with a long dc time constant. The waveform in Figure 11 has been repeated to simulate hundreds of high-speed reclosing operations in rapid succession. The ACT output current is seen to be a perfect replica of the input current.

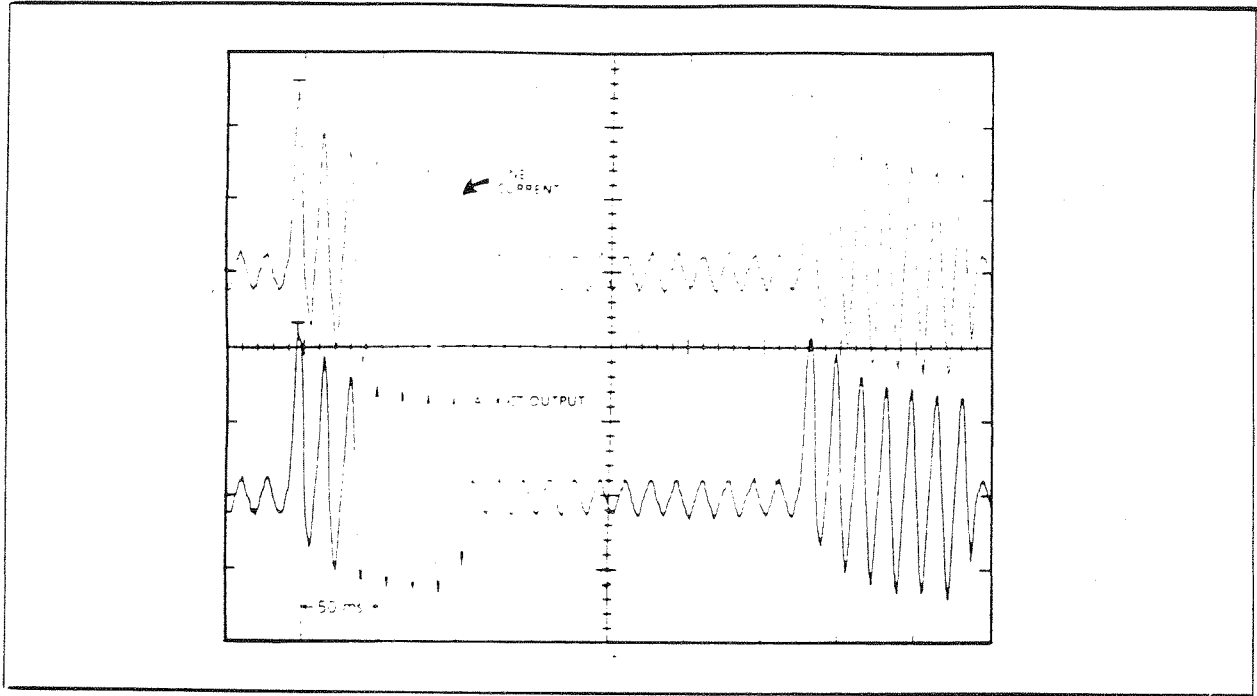

Figure 11. RFL 9300 auxiliary current transformer (ACT) test

Figure 12 shows the effect of the RFL 9300's anti-aliasing filter. The 3-dB roll-off frequency for this filter is 200 Hz. The RFL 9300's 2-kHz sampling rate provides "oversampling," even though the roll-off frequency of the filter is high when compared to other digital relays. The phase-shift introduced by this filter is equivalent to 0.7 ms at 60 Hz, which is minimal.

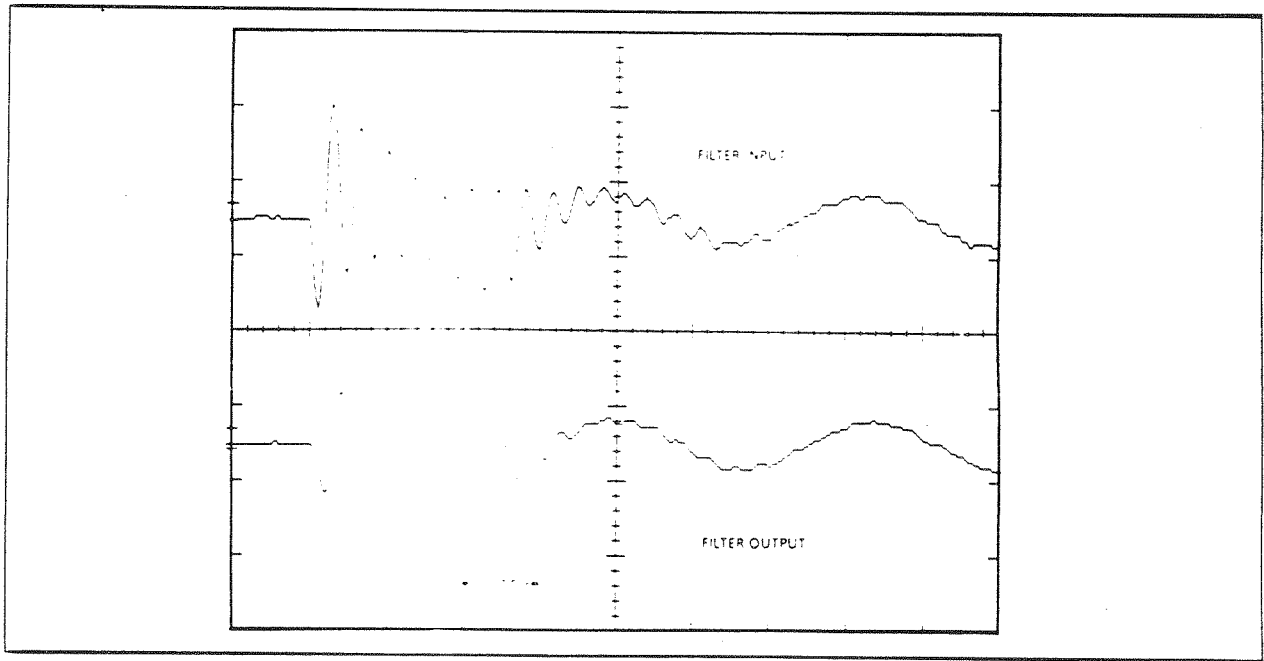

Figure 12. Effect of anti-aliasing filter, RFL 9300 Charge Comparison System

Figure 13 shows an internal fault from phase A to ground (A-G) with outfeed. The load current (6 amperes) is very high. Fault resistance limits the total fault current to three times the load current. The fault is near the strong-source terminal. The infeed effect of the strong-source current flowing through the fault resistance means that the weak-source contribution to the fault is very small. The strong-source phase-A current shown in Figure 13 is 180 degrees out-of-phase with the weak-source phase-A current, but of greater magnitude. The RFL 9300's "rainbow" characteristic correctly senses the internal fault.

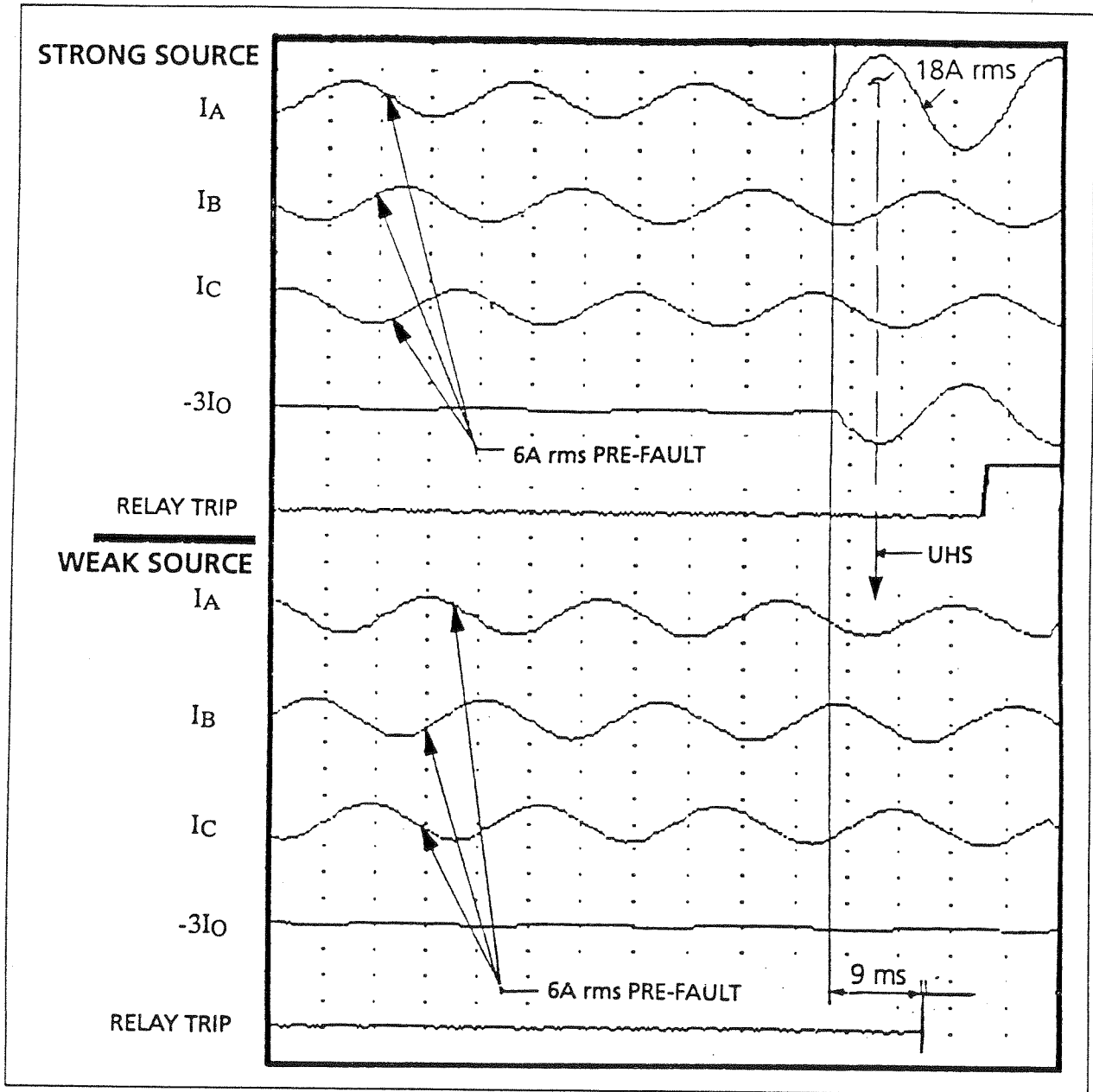

Figure 13. RFL 9300 outfeed condition, fiber optic communications channel

Figure 14 shows an internal three-phase fault with a weak-feed terminal. The weak source is a load terminal, with only a "static" (resistive) load. This is an extreme case, because it assumes no rotating load at all. For that reason, there is no regenerative fault current. The communication channel is 56-Kbps direct digital.

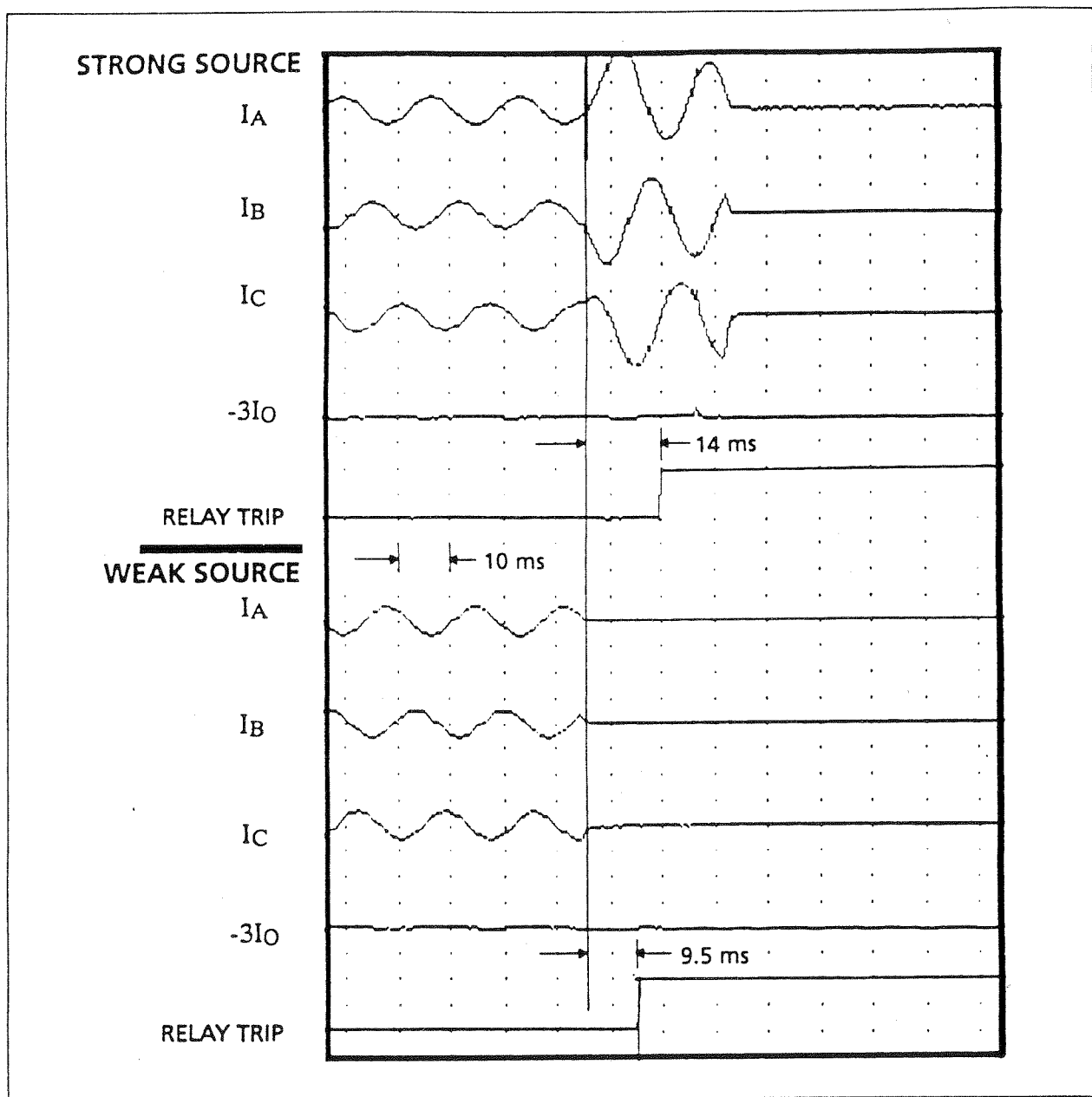

Figure 14. Weak-feed trip, 56-Kbps communication channel

The weak terminal relay trip signal is accelerated by a received "UHS" (Ultra High-Speed) message. This trip signal occurs within 9.5 ms after fault inception. An additional 4-ms delay is introduced by the multi-contact auxiliary tripping relay. The fault detectors at the weak terminal operate in response to the sudden drop in load current to almost zero. A CCT-U (Charge Comparison Trip-Ultimate) signal is sent back to the strong terminal to trip its breaker within 18 ms of fault inception. (This includes the 4 ms required to operate the strong terminal's auxiliary tripping relay.)

Figure 15 is similar to Figure 14, except the communication channel is a 7200-bps modem operating over a voice-grade line. Because the modem's 16-ms delay time is longer than the 4-ms delay time in the 56-Kbps channel shown in Figure 14, trip times are slower. The trip times are 20 ms plus 4 ms at the weak terminal, and 38 ms plus 4 ms at the strong terminal. The slower trip at the strong terminal is typical of permissive tripping schemes that require "echo" tripping from the weak terminal to allow tripping at the strong terminal.

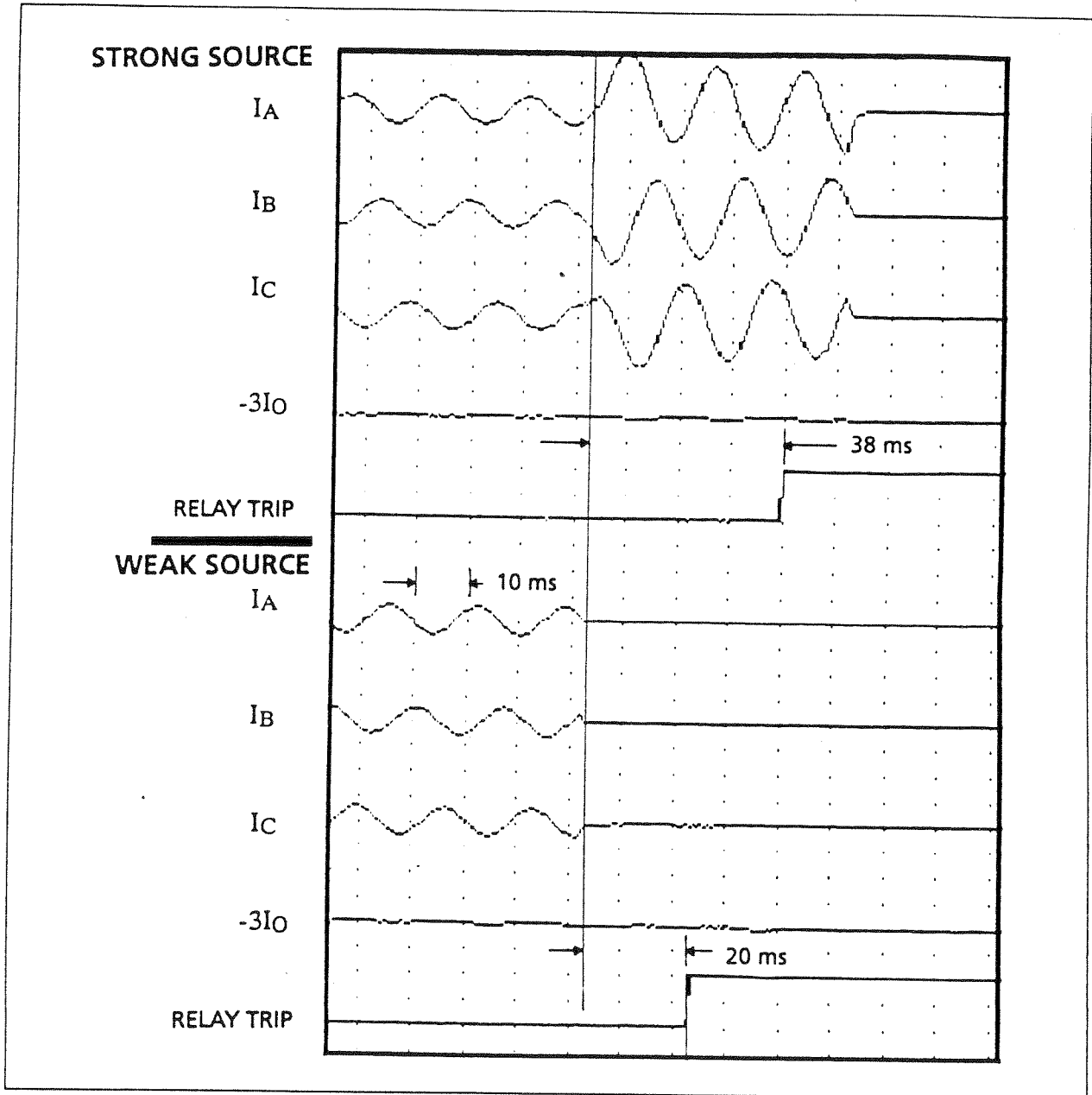

Figure 15. Weak-feed trip, 7.2-Kbps communication channel

Figure 16 shows the line charging of a very long 765-kV simulated line, with unequal pole closing. This simulation tests the security/sensitivity limit of the system for line pickup (or "switch-into-fault"). The steady-state line charging current is 1.5 amperes rms, which is equal to the system's bias level setting (or "tripping threshold"). In actual practice, the bias level would be set higher for this very long UHV line application.

The RFL 9300 bias control timer is also being tested. This timer desensitizes the system for a preset time after the breaker closes. For this test, the bias control timer was set to 50 ms. As shown, a relay trip signal occurs 64 ms after the breaker closes. Considering the relay settings for this test, this trip was expected.

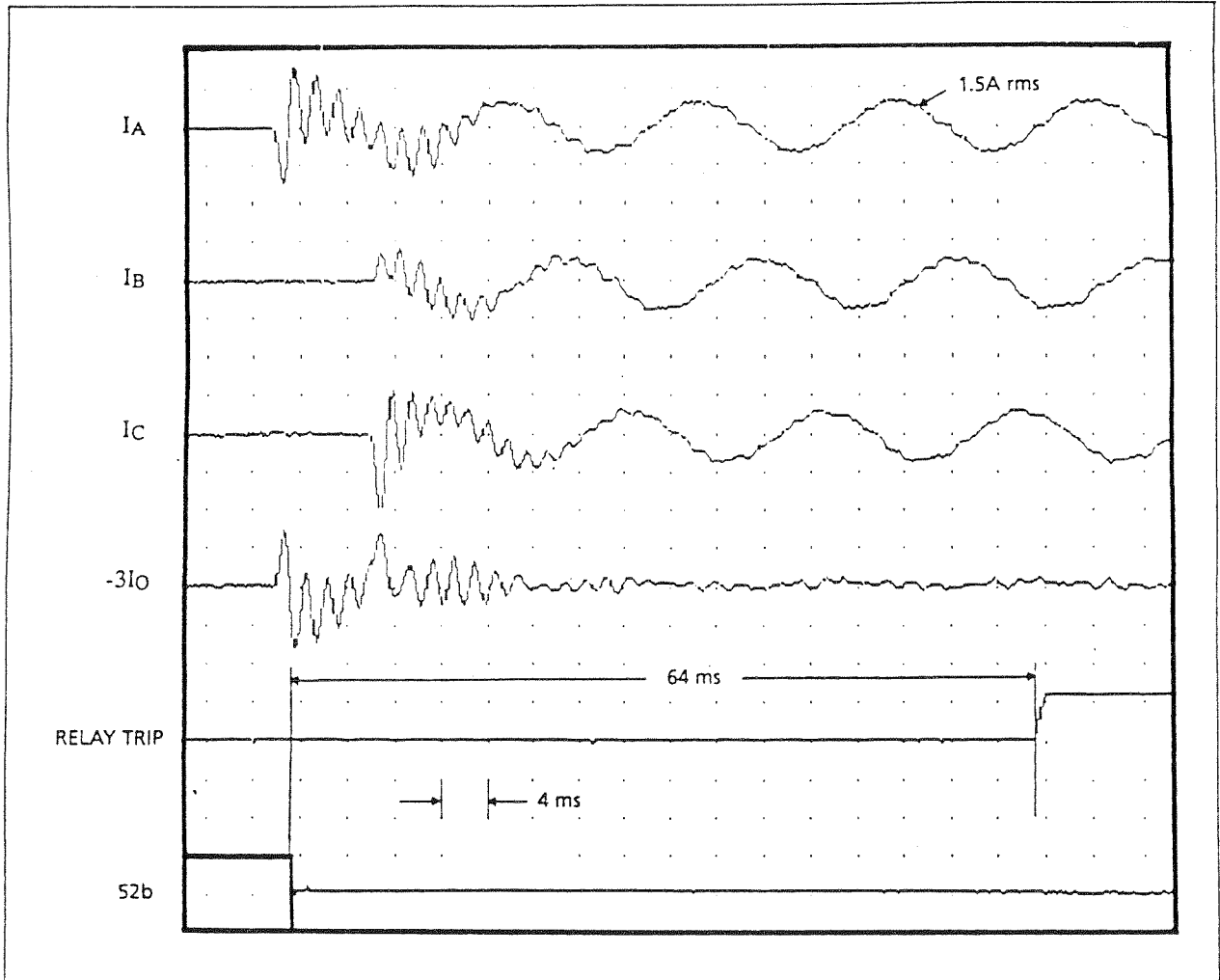

Figure 16. Line charging, long UHV line

Figure 17 shows an internal fault involving phases B and C and ground ground (BC-G). The "ground" current is shown as "-3I0" because the RFL 9300 sends CCD (Charge Comparison Data) and UHS (Ultra High Speed) messages during the *negative* half-cycle of 3I0. Figure 17 shows that this provides a 120-degree "rolling" effect for double-line-to-ground faults. This appears as $I_B/I_C/-3I_0$, in that order, at roughly 120-degree intervals. This "phase-diversity" assures a favorable tripping time on at least one subsystem for all fault incidence angles for three-phase and double-line-to-ground faults. For system stability, these are the two worst-case fault types.

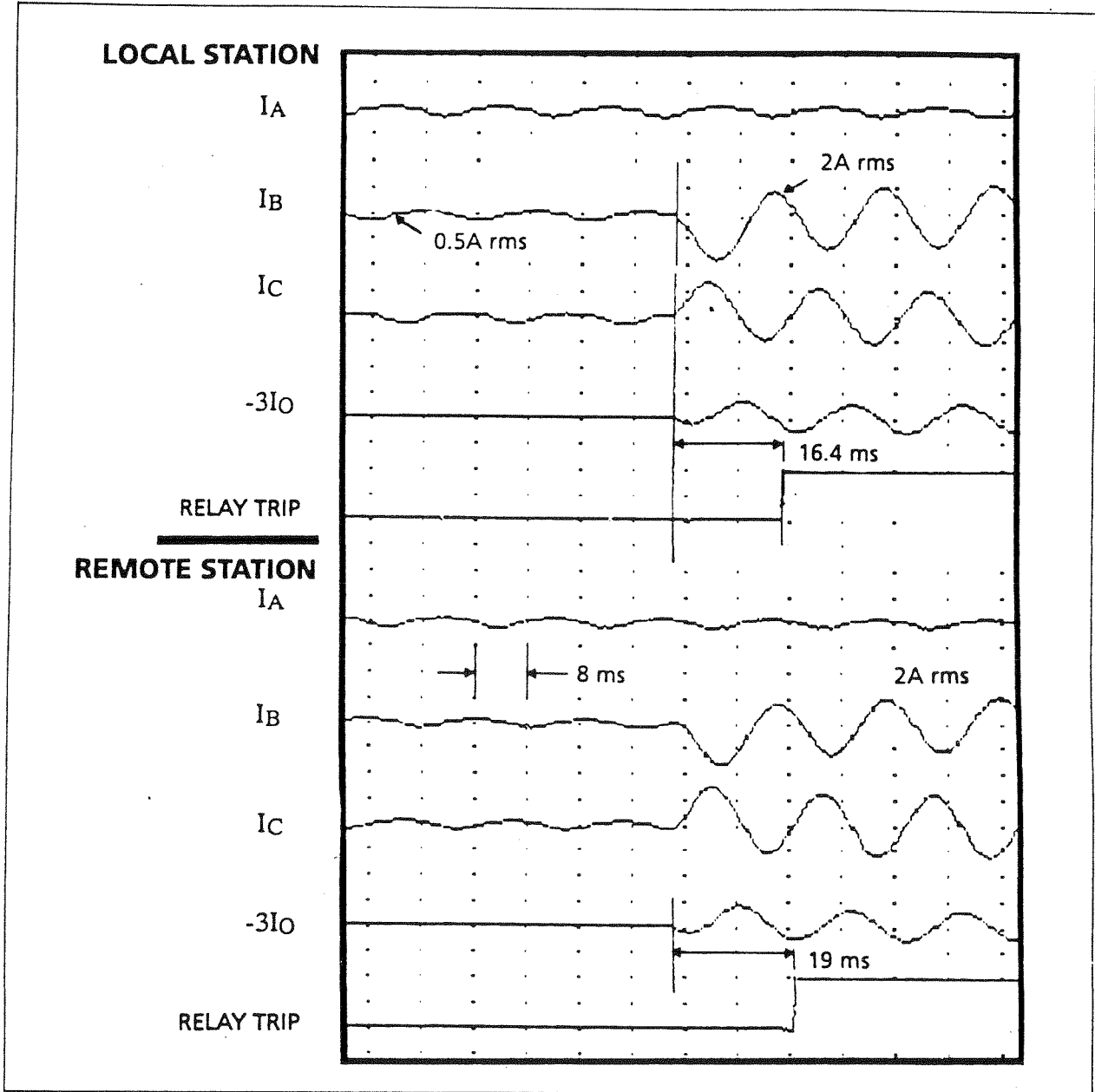

Figure 17. Internal double-line to ground (BC-G) fault

CONCLUSIONS

An alternative form of current differential relaying called "charge comparison" has been presented. The basic relaying and communications concepts of this new system have been described. These concepts have been embodied in a new product called the RFL 9300. The authors believe that charge comparison overcomes the three telecommunications-related shortcomings of current differential protection of transmission lines.

REFERENCES

1. L. J. Ernst, W. L. Hinman, D. H. Quam and J. S. Thorp, "Charge Comparison Protection of Transmission Lines - Relaying Concepts," Paper 92 WM 209-7 PWRD, presented at the IEEE/PES 1992 Winter Meeting, New York, New York, January 30, 1992.
2. "Line Protection Design Trends in the USA and Canada," IEEE Power Systems Relaying Committee Report, IEEE Transactions on Power Delivery, Vol. 3, No. 4, pp. 1530-1535, October 1988.
3. G. R. Hoffman and W. L. Hinman, U.S. Patent 4,939,617, July 1990.
4. W. A. Elmore, "Modern Transmission Line Relaying Variations," Georgia Tech Protective Relaying Conference, May 1989.
5. N. P. Albrecht, W. C. Fleck, K. J. Fodero and R. J. Ince, "Charge Comparison Protection of Transmission Lines - Communications Concepts," Paper 92 WM 210-5 PWRD, presented at the IEEE/PES 1992 Winter Meeting, New York, New York, January 30, 1992.

NOTES

Dowty Control Technologies

Powerville Road, Boonton, New Jersey 07005-0239

Phone: (201) 334-3100

Fax: (201) 334-3863

Dowty Control Technologies - Europe

Marshfield, Chippenham, Wiltshire SN14 8NN, England

Phone: 0225 891881

Fax: 0225 891440

Publication No. TP 92-005

Printed In U.S.A.

NEW PUBLICATION - Released August 12, 1992