

# Behavior of Current Transformers during Fault Conditions and Guidelines for their Selection for Protection Systems

Ljubomir A Kojovic  
Cooper Power Systems  
Franksville, WI 53126

Presented at the 27<sup>th</sup> Annual Western Power Relay Conference, October 24-26, 2000, Spokane, WA

**Abstract:** If current transformer (CT) characteristics are not properly selected for fault conditions, saturation will occur and relays can misoperate. Though some protection schemes have been designed to tolerate a certain amount of CT errors, the majority of applications need to faithfully reproduce primary currents. To help protection engineers select proper CTs, IEEE published two documents on CT performance and application. This paper compares these documents and suggests modifications to make guidelines for main and auxiliary CT selections easier and provide more realistic results for CT transient behavior.

**Keywords:** Current Transformer, Saturation, Transient Response, Digital Simulation, EMTP, ATP

## I. INTRODUCTION

CT performance characteristics are specified by C57.13-1993 ANSI/IEEE standard [1]. However, this standard only covers CT behavior under steady state and symmetrical fault conditions. In an actual power system, short circuit currents may have a significant DC offset, which may saturate CTs at several times rated current. Remanence in the CT core can also contribute to CT saturation. Therefore, it is necessary to use additional techniques to estimate CT performance during fault conditions.

IEEE published the following documents on CT performance and application: 1) Power System Relaying Report 76-Ch1130-4 [2,3], and 2) IEEE Std C37.110-1996, "IEEE Guide for the Application of Current Transformers Used for Protective Relaying Purposes" [4]. This paper compares these documents and proposes modifications to make guidelines for CT selections easier and provide more realistic results for CT transient behavior.

Section II presents the theory of CT operation. Section III compares the two IEEE documents and proposes a modified method for CT selection. Guidelines are established that apply for characteristic verification of both main and auxiliary CTs. Section IV includes computer simulations and laboratory tests of CT transient response. The Alternative Transients Program (ATP) was used for the simulations. ATP-based models, representing the protective relaying system and CTs, were developed. The models were verified by performing laboratory tests on actual CTs. They

have proven useful in solving actual industrial and utility distribution system problems. Section V presents an example of auxiliary CT application with an event resulting in protection system misoperation. A comparative analysis is presented to show how auxiliary CTs perform with characteristics selected from existing and proposed guidelines. The example also demonstrates a slight CT saturation does not affect relay operation.

## II. CURRENT TRANSFORMER TRANSIENT ANALYSIS

Current transformer connection and equivalent circuit are shown in Figures 1a and 1b.

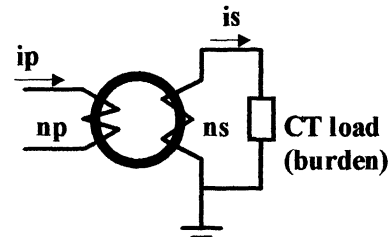
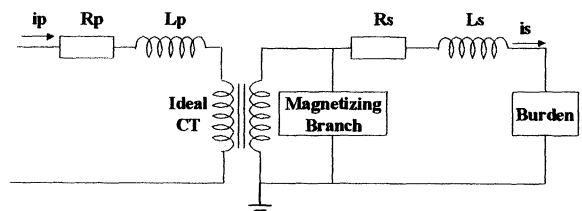

Figure 1a. Current Transformer Connection



$R_p, L_p$  - primary winding resistance and leakage inductance  
 $R_s, L_s$  - secondary winding resistance and leakage inductance

Figure 1b. Current Transformer Equivalent Circuit

An ideal CT will operate with an ampere-turn balance:

$$i_p \cdot n_p = i_s \cdot n_s \quad (1)$$

where

- $i_p$  - CT primary current
- $i_s$  - CT secondary current
- $n_p$  - number of primary turns
- $n_s$  - number of secondary turns

An actual CT does not behave as an ideal transformer. The CT secondary voltage is generated by the rate of flux change in the core. To produce flux in the CT core, magnetizing (exciting) current is needed. This current introduces ratio and phase errors.

The equation of an actual CT can be written as:

$$\vec{i}'_p = \vec{i}_s + \vec{i}_m \quad (2)$$

where  $i'_p$  is primary current referred to the secondary, and  $i_m$  is magnetizing current.

The fundamental transformer equation (3) applies to all transformers including CTs.

$$E = 4.44 B A n f \quad (3)$$

where

- $E$  - RMS voltage on the secondary winding [V]
- $B$  - flux density [T]
- $A$  - core cross section [m<sup>2</sup>]
- $f$  - frequency [Hz]
- $n$  - turns ratio

This equation can be used for steady state analysis, but in this form, is not suitable for transient analysis.

For transient analysis, the CT equivalent circuit of Figure 2 applies.

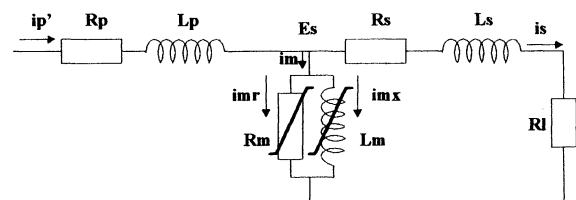

- $L_m$  - magnetizing inductance
- $E_s$  - CT secondary voltage
- $im_x$  - magnetizing current, reactive component
- $im_r$  - magnetizing current, active component
- $R_l$  - CT load (burden) including lead resistance
- $R_m$  - iron loss equivalent resistance

Figure 2. Current Transformer Circuit Diagram

To further simplify CT transient analysis, the CT equivalent circuit of Figure 2 can be simplified as shown in Figure 3. CT parameters  $R_p$ ,  $L_p$ , and  $R_m$  can be neglected. In the following analysis  $L_s$  was also neglected, although in some cases it may be taken into consideration. Inter-winding capacitance can be neglected too at the frequencies of interest to protection studies [5].

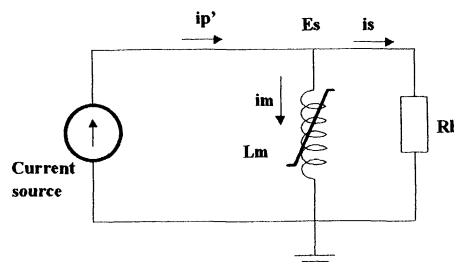

Figure 3. CT Representation for Transient Analysis

$$R_b = R_s + R_l \quad (4)$$

$$\text{CT time constant can be defined as } T_2 = \frac{L_m}{R_b} \quad (5)$$

The magnetizing branch  $L_m$  is a non-linear element. It can be estimated from the CT V-I characteristics which is readily available.  $R_b$  value is also usually provided.  $L_m$  and  $R_b$  data is sufficient to develop CT models.

The most important transient condition to be considered in CT operation is an asymmetric short circuit current since, due to a DC component, the CT will saturate at lower currents than for symmetrical short circuit currents.

The short circuit current can be expressed as:

$$i(t) = I_{peak} [\sin(\omega t + \alpha - \varphi) + \sin(\alpha - \varphi) e^{-\frac{t}{T_1}}] \quad (6)$$

where

- $i(t)$  - current instantaneous value
- $I_{peak}$  - current peak value
- $\alpha$  - fault incidence angle
- $\varphi$  - phase angle between voltage and current
- $T_1$  - primary circuit time constant

The most severe case is a full offset of short circuit current which is obtained for  $\alpha - \varphi = \frac{\pi}{2}$  and represented by equation:

$$i(t) = I_{peak} [e^{-\frac{t}{T_1}} - \cos(\omega t)] \quad (7)$$

Standards [1] specify CT behavior only under steady state and symmetrical fault conditions. CT ratio error is specified to be 10% or better for fault currents of 20 times the CT rated current and specified load. CTs are designed to meet this requirement. But, if a symmetric fault current exceeds 20 times the CT rated current or if the fault current is smaller but contains DC offset (asymmetric current), the CT will saturate and secondary current will be distorted and have reduced RMS value. Figure 4 demonstrates levels of 600/5 A, C100 CT saturation for different symmetric fault currents. CT ratio errors, calculated based on the current

RMS value, at different saturation levels are correlated to CT operating points on the V-I curve.

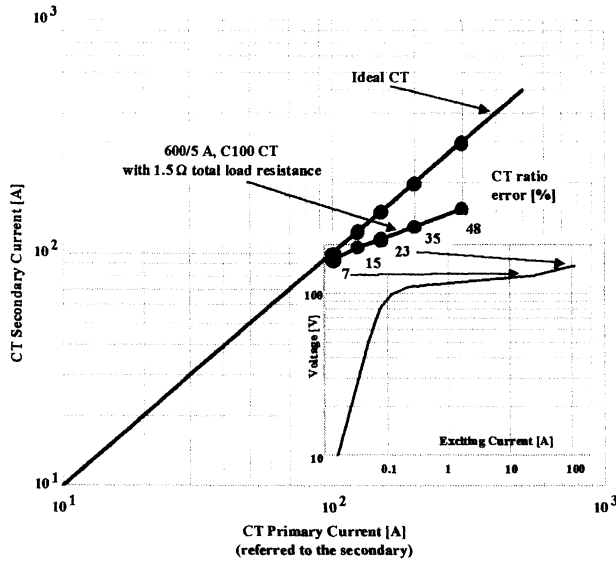

Figure 4. 600/5 A, C100 Current Transformer Saturation

### III. METHODS FOR CT SELECTION

IEEE published two documents on CT performance and application. This section compares these documents and suggests modifications to the guidelines for CT selection. These methods estimate if a CT will saturate under fault conditions, but they do not indicate the intensity of saturation and possible impact on relay operation. Additional analysis is required to study the impact on relay protection if CT saturation occurs.

**Method #1:** To make CT transient analysis easier for users, the Power System Relaying Report 76-Ch1130-4 [2,3] includes guidelines for CT selection. It first defines a saturation factor ( $K_s$ ) as

$$K_s = \frac{V_k}{V_s} = \frac{V_k}{\frac{I_p}{n} R_b} \quad (8)$$

$K_s$  represents the ratio of the CT saturation voltage ( $V_k$ ) to the CT secondary voltage ( $V_s$ ) for a symmetrical fault, and a measure of the safety margin available.

Report [2] includes a family of  $K_s$  curves which can be used to estimate a CT transient response based on the  $K_s$  value from which the time to CT saturation can be determined. Figure 5 shows an example of  $K_s$  curves for primary circuit time constant  $T_1=20$  ms and current transformer time constants  $T_2=0.1, 0.3, 0.6, 1, 2,$  and  $10$  s. If  $K_s$  value exceeds the curve for a particular  $T_2$ , the CT will not saturate.

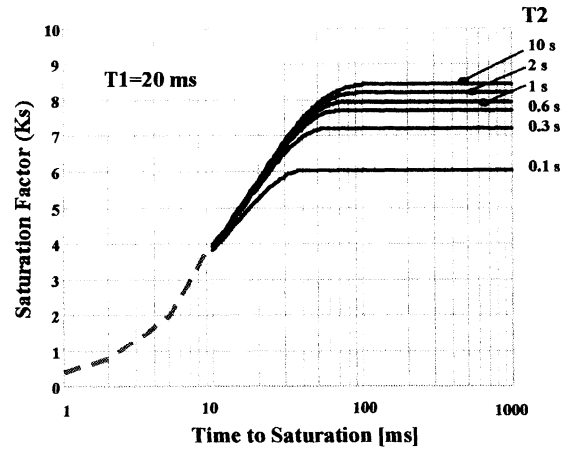

Figure 5. Saturation Factor ( $K_s$ ) and Time to Saturation for Primary Circuit Time Constant  $T_1=20$  ms and Different Current Transformer Time Constants ( $T_2$ )

The procedure to obtain  $K_s$  curves was as follows: Using the CT equivalent circuit of Figure 2, flux density in the CT core for a resistive burden was approximated with Equation 9:

$$B(t) = \frac{\sqrt{2} I_p R_b}{A n^2} \left[ \frac{T_1 T_2}{T_2 - T_1} \left( e^{-\frac{t}{T_2}} - e^{-\frac{t}{T_1}} \right) - \sin(\omega t) \right] \quad (9)$$

Flux density at the saturation point is

$$B_k = \frac{\sqrt{2} V_k}{\omega n A} \quad (10)$$

Setting  $B_k=B(t)$  and rearranging yields

$$K_s = \frac{V_k}{\frac{i_p}{n} R_b} = \omega \frac{T_1 T_2}{T_2 - T_1} \left( e^{-\frac{t}{T_2}} - e^{-\frac{t}{T_1}} \right) - \sin(\omega t) \quad (11)$$

The second term of Equation 11 has a maximum value for  $\sin(\omega t) = -1$ . Therefore, the pessimistic value for  $K_s$  is:

$$K_s = \omega \frac{T_1 T_2}{T_2 - T_1} \left( e^{-\frac{t}{T_2}} - e^{-\frac{t}{T_1}} \right) + 1 \quad (12)$$

$K_s$  curves in reference [2] are developed based on Equation 12. Comparison of  $K_s$  curves for  $T_1=20$  ms and  $T_2=1$  s obtained using Equation 11 with the  $K_s$  curve from the reference [2] (Equation 12) is shown in Figure 6. The maximum value of Equation 11 defines  $K_s$  above which the CT will not saturate. Therefore, a straight line was drawn starting from the maximum value. Also, the beginning part of  $K_s$  curves (dotted lines in Figures 5 and 6) are not drawn based on Equation 12 but were adjusted to represent more realistic CT response since Equation 12 in that region gives more pessimistic results. The report does not provide an explanation based on this adjustment.

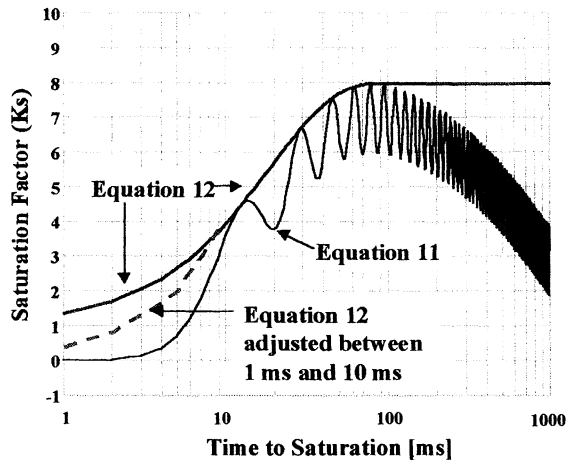

Figure 6. Saturation Factor ( $K_s$ ) Curves for  $T_1=20$  ms and  $T_2=1$  s

Figure 7 shows a families of  $K_s$  curves for  $T_1=0.02, 0.04, 0.06, 0.08,$  and  $0.1$  s and  $T_2= 0.1, 1,$  and  $10$  s developed based on reference [2].

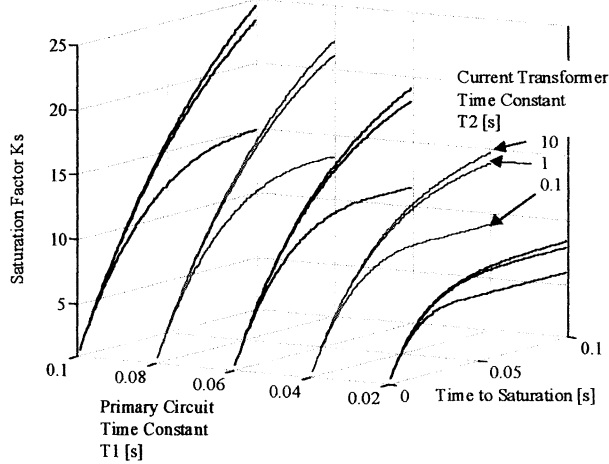

Figure 7. Saturation Factor Curves vs. Primary Circuit ( $T_1$ ) and CT Time Constants ( $T_2$ )

**Comments:** Figure 7 indicates that for a CT with higher time constant  $T_2$ , a higher value of  $K_s$  is required to avoid CT saturation. This is not correct since the CT time constant increases when  $R_b$  decreases. This incorrect indication results from Equation 12 because the variable  $R_b$  exists on both sides of Equation 12. When calculating  $K_s$  curves, only  $R_b$  on the right side of Equation 12 was handled as a variable. However, when applying  $K_s$  curves, this error becomes “corrected” because  $K_s$  must be first calculated from Equation 8, which includes  $R_b$ . For a CT,  $K_s$  is higher with smaller  $R_b$  and also  $K_s$  is smaller with higher  $R_b$ .  $K_s$  is then checked against  $K_s$  curves in Figure 7 and the results become appropriate.

Even though the first part of  $K_s$  curves was adjusted (dotted line, Figures 5 and 6), they give more pessimistic results than actual CT transient response in that region.

**Method #2:** IEEE Std C37.110-1996 [4] further simplifies CT transient analysis by assuming  $T_2$  to be infinite on the right side of Equation 12. This reduces Equation 12 to equation 13:

$$K_s = \omega T_1 \left( 1 - e^{-\frac{t}{T_1}} \right) + 1 \quad (13)$$

From equation 13, time to saturation ( $t_s$ ) is

$$t_s = -T_1 \cdot \ln \left( 1 - \frac{K_s - 1}{\omega T_1} \right) = -T_1 \cdot \ln \left( 1 - \frac{K_s - 1}{\frac{X_1}{R_1}} \right) \quad (14)$$

$T_1 = \frac{X_1}{\omega R_1}$ , where  $X_1$  and  $R_1$  are primary system reactance and resistance up to the fault. Equation 14 is included in [4].

**Comments:** In Equation 14,  $T_2$  was assumed to be infinite which suggests  $L_m + L_s = \infty$  or  $R_b = 0$ . Again, this assumption was applied only to  $T_2$  of Equation 12, not to  $K_s$  which is also defined by  $R_b$ . This produces pessimistic results for CTs having small time constants such as auxiliary CTs and CTs having low saturation voltage. This is shown in the next section.

**Proposed Method (Method #3):** This paper proposes use of  $V_k$  instead of  $K_s$  (Equation 12) or  $t_s$  (Equation 14) since it is easier to visualize how a CT will perform. For determining the CT time to saturation, the use of two equations (Equation 15 and 16) is also proposed.

From Equation 11,  $V_k$  can be expressed as shown in Equation 15.

$$V_k = i_s R_b \left[ \omega \frac{T_1 T_2}{T_2 - T_1} \left( e^{-\frac{t}{T_2}} - e^{-\frac{t}{T_1}} \right) - \sin(\omega t) \right] \quad (15)$$

where  $i_s = \frac{i_p}{n}$

To estimate CT time to saturation, Equation 15 is used as is, with  $\sin(\omega t)$  until the first peak as shown in Figure 8. This gives more realistic CT response for this time range. After the first peak,  $\sin(\omega t) = -1$  is assumed which represents a pessimistic value as given in Equation 16.

$$V_k = i_s R_b \left[ \omega \frac{T_1 T_2}{T_2 - T_1} \left( e^{-\frac{t}{T_2}} - e^{-\frac{t}{T_1}} \right) + 1 \right] \quad (16)$$

Figure 9 shows a C800 CT time to saturation for a fault of 20 times the rated current,  $T_1=0.02$  s and  $R_b=0.5 \Omega$  and  $1 \Omega$ . In this case, the CT will not saturate for  $R_b=0.5 \Omega$  but will saturate for  $R_b=1 \Omega$  after 50 ms. Figure 10 extends the results over a range of  $T_1$ .

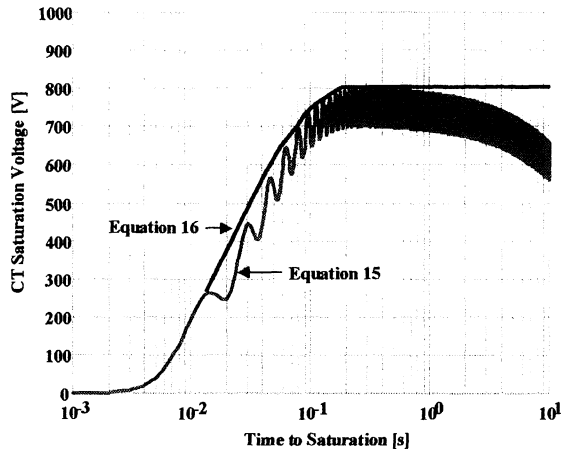

Figure 8. Method #3 to Estimate the CT Time to Saturation

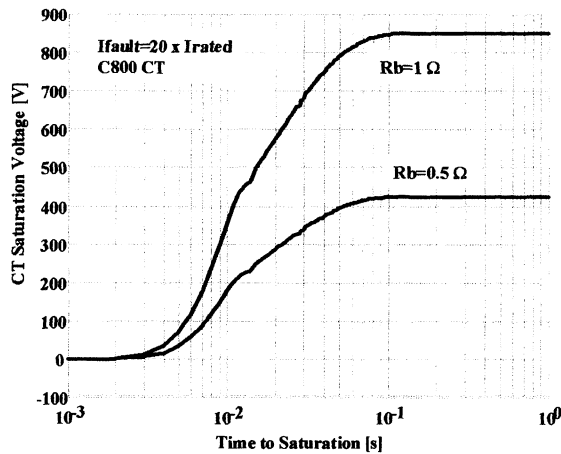

Figure 9. Method #3 to Estimate CT Time to Saturation (CT Class: C800, Fault current: 20 times the rated current,  $T_1=0.02$  s, CT Burden:  $0.5 \Omega$  and  $1 \Omega$ )

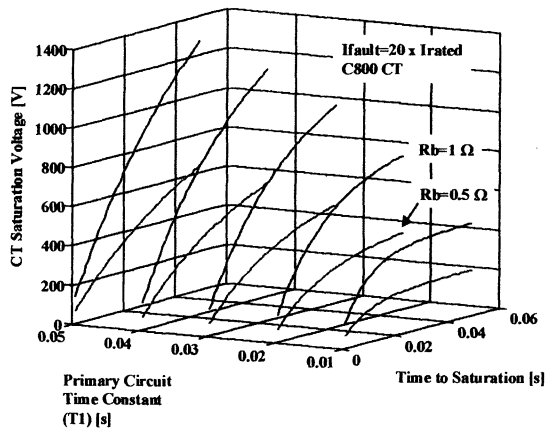

Figure 10. C800 CT Time to Saturation Curves using Method #3 for a 20 Times Rated Current Fault vs. the CT  $V_k$ ,  $T_1$ , and  $R_b=0.5 \Omega$  and  $R_b=1 \Omega$

A comparison between Methods #1 and #2 and Method #3 is shown in Figure 11. Method #2 gives the most pessimistic results for CTs having lower  $V_k$  indicating CTs will saturate faster than in actual practice (portion of the curve from 1 ms to 10 ms in Figure 11). Method #1

has slightly corrected that portion of the curve. Method #3 uses  $\sin(\omega t)$  in that range which gives results closer to results obtained by testing actual CTs. Method #2 also incorrectly indicates that in some CT applications, CTs need higher  $V_k$  to avoid saturation than Method #1 and Method #3 which give more realistic results.

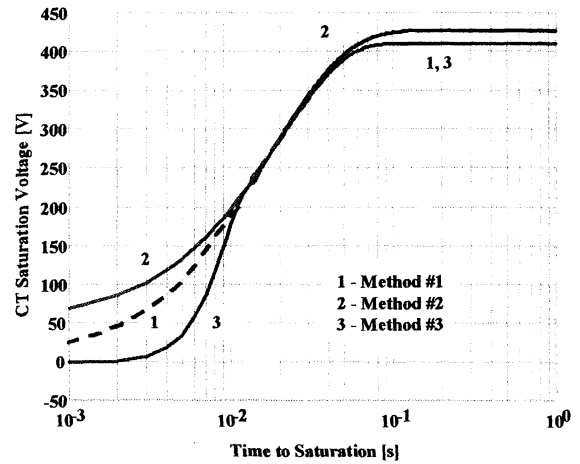

Figure 11. Comparison between Method #3 and Methods #1 and #2 to Estimate CT Transient Behavior

#### Criteria to avoid CT saturation:

A fast method to estimate if a CT will saturate is to apply criteria for CT saturation. References [4,6] derive criteria to avoid CT saturation. For a resistive load it is expressed by Equation 17.

$$V_k = i_s R_b \left( \frac{X_1}{R_1} + 1 \right) \quad (17)$$

The same criteria can be obtained from Equation 12 which can be rewritten as Equation 18.

$$V_k = i_s R_b \left[ \omega \frac{T_1 T_2}{T_2 - T_1} \left( e^{-\frac{t}{T_2}} - e^{-\frac{t}{T_1}} \right) + 1 \right] \quad (18)$$

$T_2$  is much larger than  $T_1$  and Equation 17 can be reduced to Equation 19.

$$V_k = i_s R_b \left[ \omega T_1 \left( 1 - e^{-\frac{t}{T_1}} \right) + 1 \right] \quad (19)$$

The most pessimistic value for  $V_k$  is when  $e^{-\frac{t}{T_1}} = 0$ , so Equation 19 can be further reduced to Equation 20 which is identical to Equation 17.

$$V_k = i_s R_b (\omega T_1 + 1) \quad (20)$$

Comments: This method, like Method #2, gives more pessimistic results.

**Remanent Flux**, or remanence, results from the interruption of the CT primary current when the core flux is not zero. Depending on the type of steel, remanent flux may be a high percent of the saturation flux (80% for ARMCO M4). Distortion of the secondary current, particularly in the first few cycles after the inception of a fault, is greatly influenced by the amount of remanent flux. The distortion can have an adverse effect on the operation of high-speed relays. The methods presented in this section do not include remanence.

#### IV. LABORATORY TESTS AND COMPUTER SIMULATIONS

This section compares the methods discussed in Section III to determine time to saturation for a 600/5 A, C100 and a 2000/5 A, C800 current transformers. Laboratory tests and computer simulations were performed. The ATP program was used to simulate CT transient behavior. CT models were then compared to laboratory tests.

##### 4.1. 600/5 A, C100 CT Transient Response

Figure 12 shows the V-I curve for a 600/5 A CT, C100 obtained by measurement. Several laboratory tests were performed at different current levels and closing angles. Figures 13 and 14 compare tested and simulated CT response with  $R_b=1\Omega$  to a 6 kA fault with  $T_1=20$  ms. Tested and simulated waveforms are very similar, verifying the computer modeling. Figure 15 compares CT response with  $R_b=1\Omega$  and  $R_b=10\Omega$  to a 6 kA fault with  $T_1=20$  ms. Estimated time to saturation using different methods are presented in Table 1.

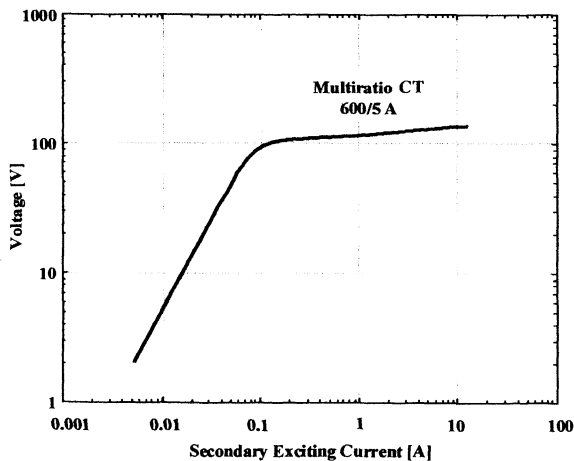

Figure 12. V-I Curve for a 600/5 A CT, C100

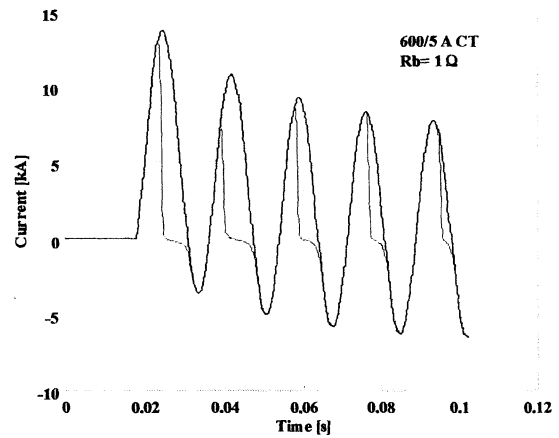

Figure 13. Transient Response of a 600/5 A CT, C100 with  $R_b=1\Omega$  to a 6 kA Fault with  $T_1=20$  ms (laboratory test)

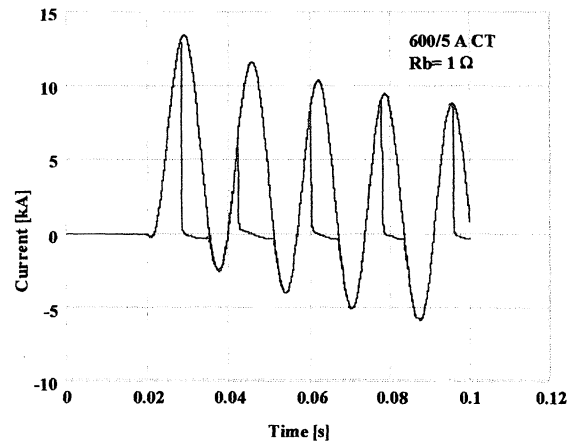

Figure 14. Transient Response of a 600/5 A CT, C100 with  $R_b=1\Omega$  to a 6 kA Fault with  $T_1=20$  ms (computer simulation)

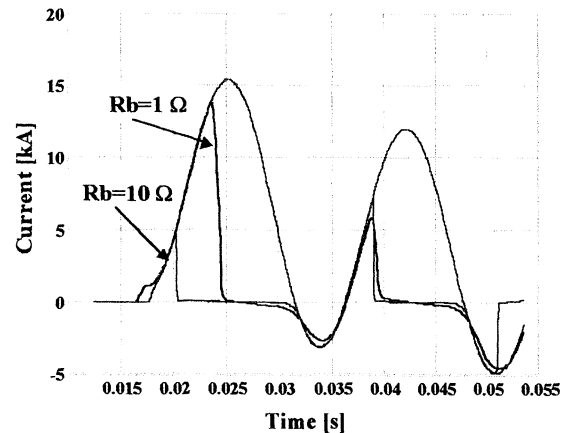

Figure 15. Transient Response of a 600/5 A CT, C100 with  $R_b=1\Omega$  and  $R_b=10\Omega$  to a 6 kA Fault with  $T_1=20$  ms (laboratory test)

Table 1. Time-to-Saturation for a 600/5 A, C-100 CT, Fault Current 6 kA<sub>RMS</sub>, T<sub>1</sub>=20 ms

	Time-to-Saturation [ms]	
	Rb=1 Ω	Rb=10 Ω
- Method #1 [2]	5*	<1*
- Method #2 [4]	3	<1
- Method #3	7	3.2
- Laboratory Test	7	2.6
- Simulation	7	2.7

\* - Dotted line region (uncertain)

Comments: Table 1 indicates that both Method #1 and Method #2 are more pessimistic than Method #3, where results are closer to tested and simulated results.

#### 4.2. 2000/5 A, C800 CT Transient Response

The comparison presented in this section is based on computer simulations. Figure 16 shows a V-I curve for a 2000/5 A CT, C800. Figures 17-25 give CT transient response to a 14 kA full-offset fault with T<sub>1</sub>=20ms, 60ms, and 100ms, and Rb=1Ω, 5Ω, and 10Ω. Results are presented in Table 2.

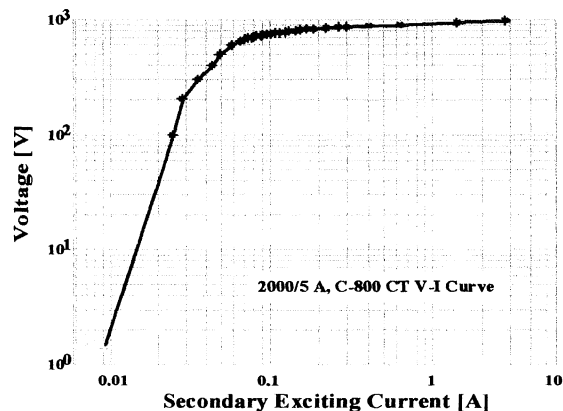

Figure 16. V-I Curve for a 2000/5 A CT, C800

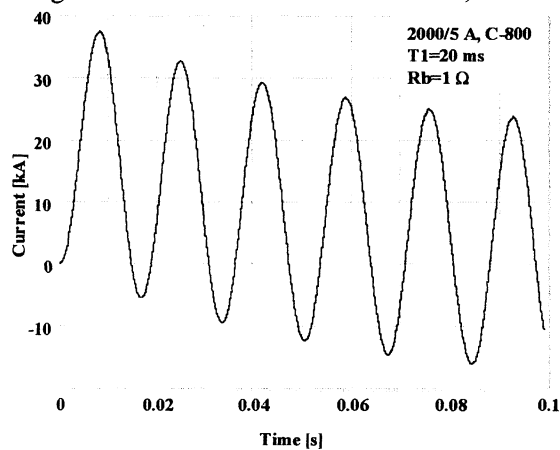

Figure 17. Transient Response of a 2000/5 A CT, C800 with Rb=1Ω to a 14 kA Full-Offset Fault with T<sub>1</sub>=20 ms (computer simulation)

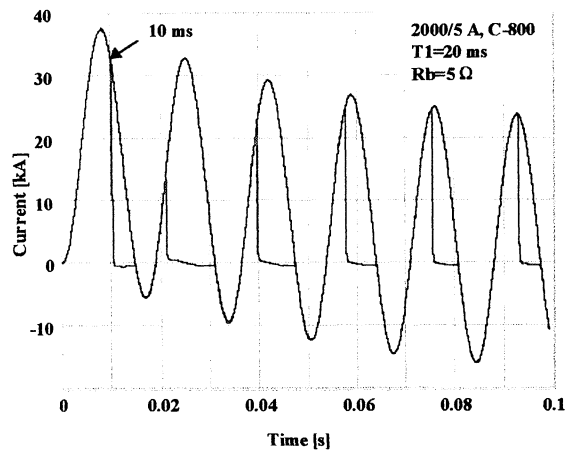

Figure 18. Transient Response of a 2000/5 A CT, C800 with Rb=5Ω to a 14 kA Full-Offset Fault with T<sub>1</sub>=20 ms (computer simulation)

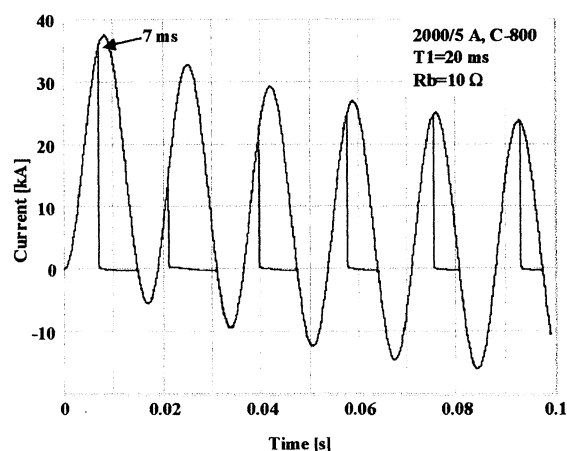

Figure 19. Transient Response of a 2000/5 A CT, C800 with Rb=10Ω to a 14 kA Full-Offset Fault with T<sub>1</sub>=20 ms (computer simulation)

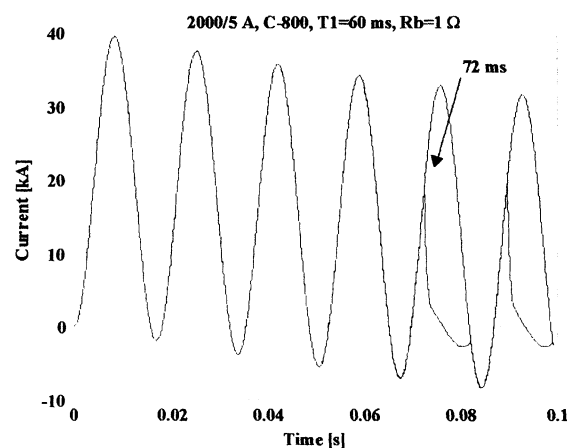

Figure 20. Transient Response of a 2000/5 A CT, C800 with Rb=1Ω to a 14 kA Full-Offset Fault with T<sub>1</sub>=60 ms (computer simulation)

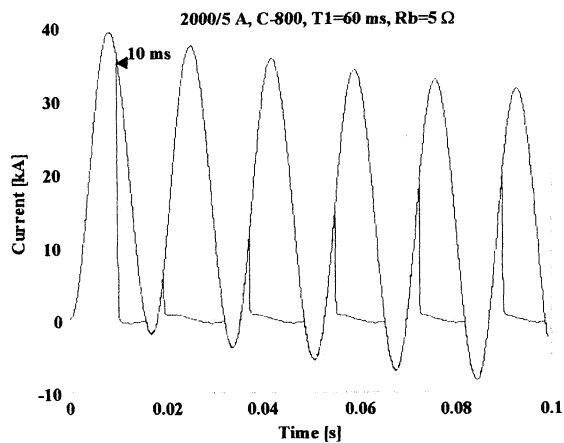

Figure 21. Transient Response of a 2000/5 A CT, C800 with R<sub>b</sub>=5Ω to a 14 kA Full-Offset Fault with T<sub>1</sub>=60 ms (computer simulation)

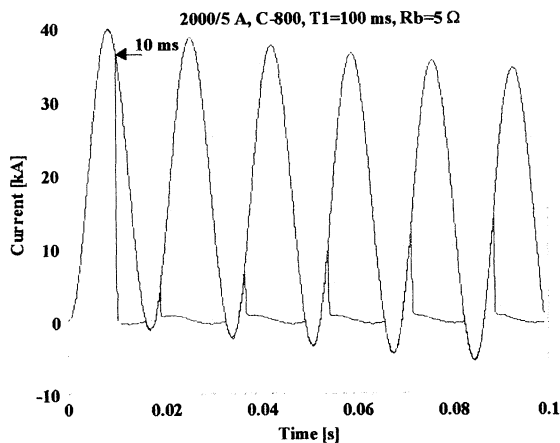

Figure 24. Transient Response of a 2000/5 A CT, C800 with R<sub>b</sub>=5Ω to a 14 kA Full-Offset Fault with T<sub>1</sub>=100 ms (computer simulation)

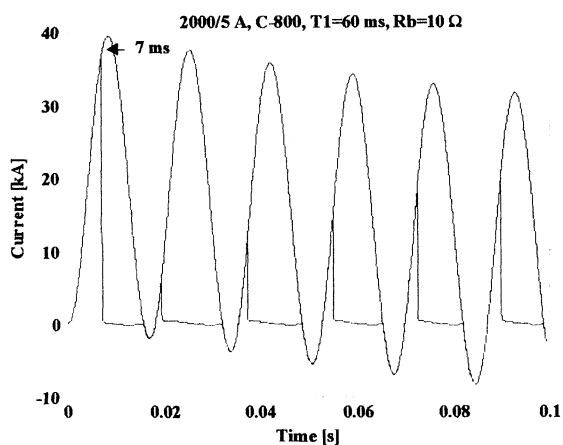

Figure 22. Transient Response of a 2000/5 A CT, C800 with R<sub>b</sub>=10Ω to a 14 kA Full-Offset Fault with T<sub>1</sub>=60 ms (computer simulation)

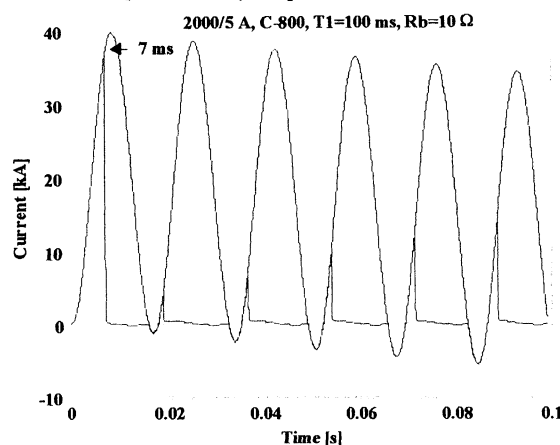

Figure 25. Transient Response of a 2000/5 A CT, C800 with R<sub>b</sub>=10Ω to a 14 kA Full-Offset Fault with T<sub>1</sub>=100 ms (computer simulation)

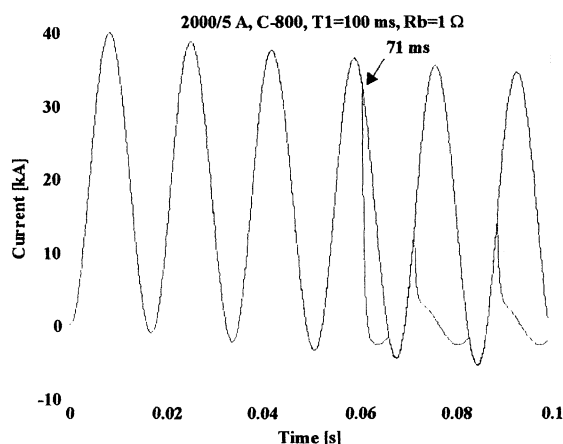

Figure 23. Transient Response of a 2000/5 A CT, C800 with R<sub>b</sub>=1Ω to a 14 kA Full-Offset Fault with T<sub>1</sub>=100 ms (computer simulation)

Table 2. Time-to-Saturation for a 2000/5 A, C-800 CT, Fault Current 14 kA RMS

		Time-to-Saturation [ms]		
		R <sub>b</sub> =1 Ω	R <sub>b</sub> =5 Ω	R <sub>b</sub> =10 Ω
T <sub>1</sub> =20 ms	Method #1	No	10	5*
	Method #2	No	13	3.8
	Method #3	No	13	7.5
	Simulation	No	10	7
T <sub>1</sub> =60 ms	Method #1	No	10	5*
	Method #2	110	10	3.5
	Method #3	110	11	7.4
	Simulation	75	10	7
T <sub>1</sub> =100 ms	Method #1	88	10	5*
	Method #2	85	10	3.5
	Method #3	85	10	7.2
	Simulation	71	10	7

No - No saturation

\* - Dotted line region (uncertain)

Comments: Table 2 indicates all methods give similar results for  $R_b=1\Omega$  and  $5\Omega$ , while for  $R_b=10\Omega$ , Methods #1 and #2 give more pessimistic results than Method #3, which gives results closer to simulated values.

## V. AUXILIARY CURRENT TRANSFORMER APPLICATION

This section includes one example of transformer ground differential relay (GDR) misoperation during a three-phase fault resulting from improper auxiliary CT selection. More examples of main and auxiliary CT applications and selection are given in [7,8]. This example includes four transformers connected in parallel to a substation bus. The three-phase X/R ratio at the substation bus was 41 and the symmetrical three-phase fault current contribution from each transformer was  $7200 A_{RMS}$ . GDR protection operated for all transformers. Figure 26 shows a single line diagram for one transformer. Since all four GDRs operated, it was concluded that equipment design and settings were the same for each transformer and they did not cause the relay operation. It was, therefore, suspected that phase current transformer saturation caused the GDR protection misoperation since the neutral current transformers should not saturate for a three-phase fault because neutral current is very small. When phase current transformers saturate, they generate false residual current flow through the GDR relay. To verify this hypothesis, a three-phase fault was simulated.

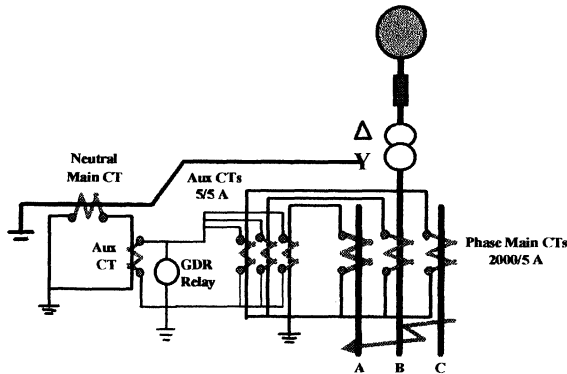

Figure 26. Computer Model for Studying Ground Differential Protection Misoperation with Main and Auxiliary Current Transformer Representation

Main and auxiliary current transformers were modeled from actual saturation characteristic data. Every model was verified against measured data. Measured and simulated CT curves were essentially identical. Figure 27 shows the auxiliary 5/5 A CT V-I characteristic.

The three-phase fault current waveforms seen by the Main 2000/5 A CT primary are given in Figure 28. The corresponding secondary currents in Figure 29 indicate that the Main CTs do not saturate. However, the distorted

waveforms in Figure 30 indicate the Auxiliary 5/5 A CTs saturated.

Figure 31 shows current through the GDR relay during the fault. The RMS value of current through the relay is given in Figure 32. A current magnitude of 7.5 A for 20 ms was enough to operate the relay's instantaneous element. This same amount of current will flow through relays of other transformers and cause their misoperation.

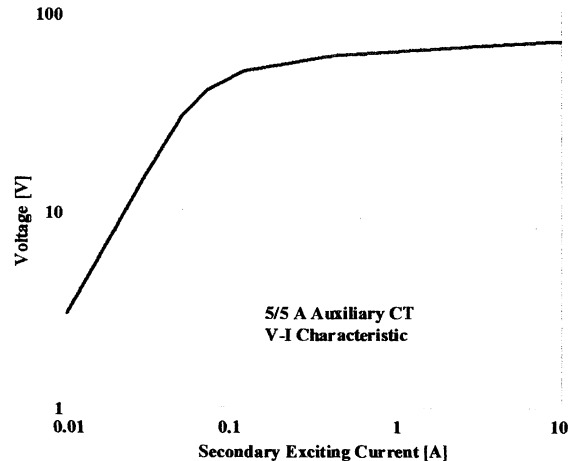

Figure 27. The 5/5 A Auxiliary CT V-I Characteristic

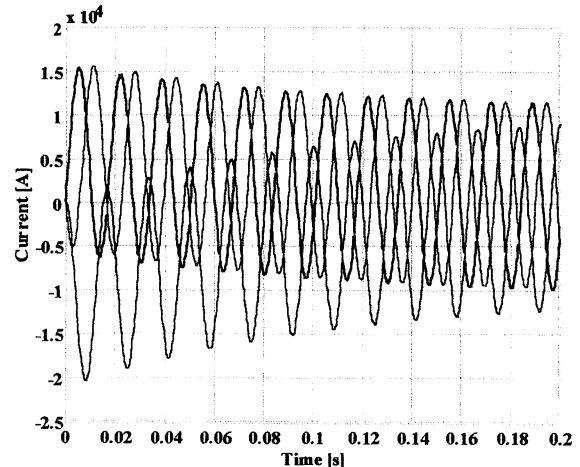

Figure 28. Primary Three-Phase Fault Currents Representing One Transformer

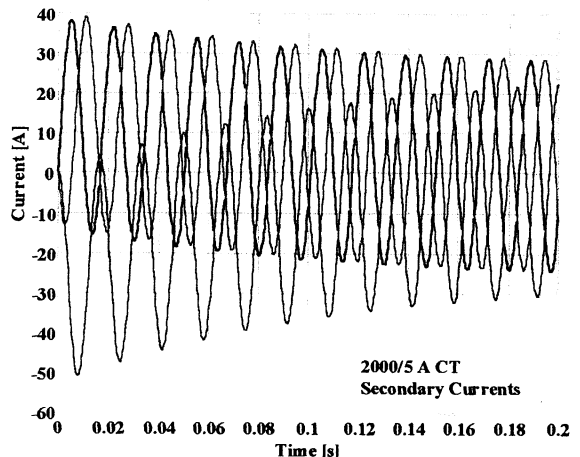

Figure 29. Main 2000/5 A CT Secondary Currents

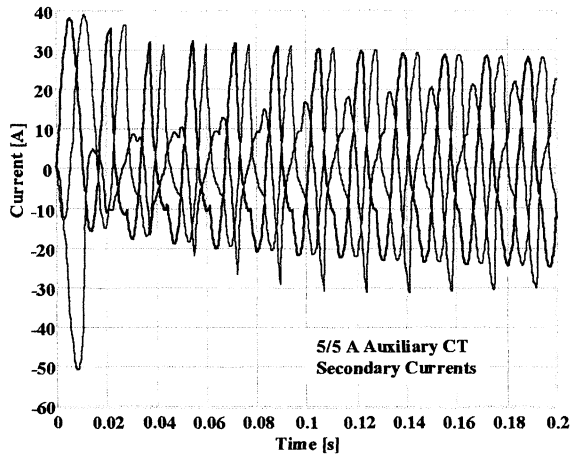

Figure 30. Auxiliary 5/5 A CT Secondary Currents

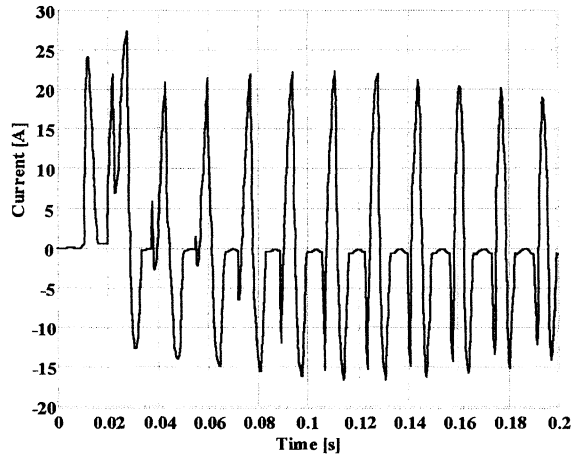

Figure 31. Current through the GDR Relay during the Fault

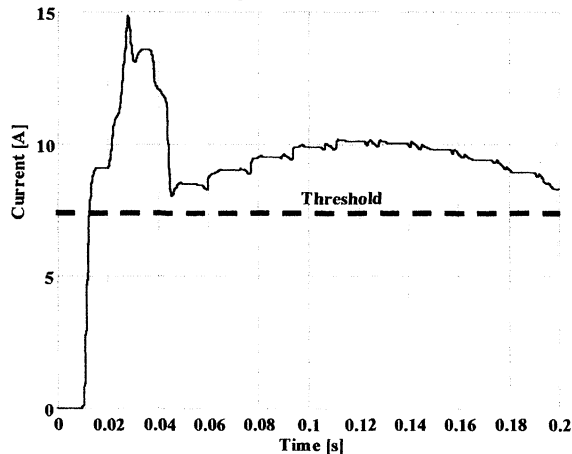

Figure 32. RMS Value of Current through the GDR Relay during the Fault

**Comments:** Figure 33 indicates all three methods give the same results. The existing auxiliary CT will saturate after 11 ms which is consistent with the simulations. A CT with similar wire resistance and  $T_2$  having  $V_k=450$  V is needed to avoid the saturation (Figure 33). Method #2 indicates the CT needs  $V_k=550$  V. When selecting auxiliary CTs with higher  $V_k$ , both main and auxiliary CT transient response must be checked. A T400 CT was available. Figure 33

closely represents time to saturation for this CT too and shows that T400 CT will also saturate, but it does not indicate the intensity of saturation. ATP simulations were performed to determine if this CT could be used. Figure 34 shows current through the GDR relay during a three-phase fault using a 5/5 A, T400 auxiliary CT. A current peak value is 6.5 A and the waveform indicates the DC component is dominant. Figure 35 gives harmonic components (all components and also components without DC, since some digital relays attenuate DC component). The RMS value of all components, including DC component, is 5.5 A. Without a DC component, the RMS value is less than 1.5 A. This verifies the T400 auxiliary CT can be used in this application.

Presented methods for CT selection provide information for CT saturation, but do not provide the intensity of saturation. Therefore, even if a method indicates a CT will saturate, a computer study can determine the CT transient behavior and the CT applicability for a particular protection.

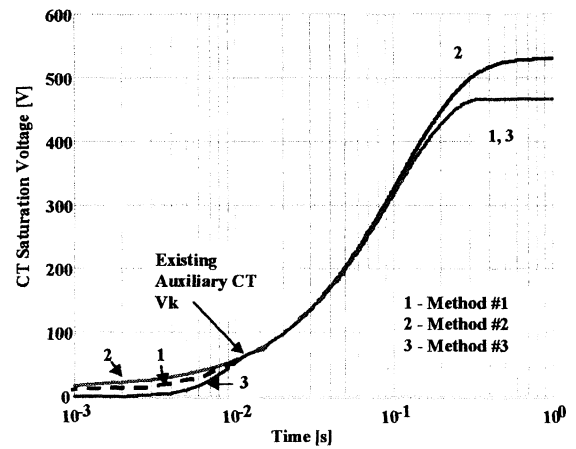

Figure 33. Comparison between Method #3 and Methods #1 and #2 to Estimate Auxiliary CT Transient Behavior

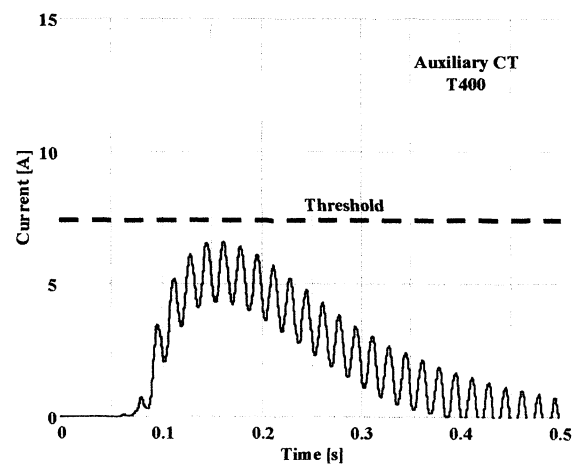

Figure 34. Current Through the Relay during the Fault with T400 Auxiliary CT

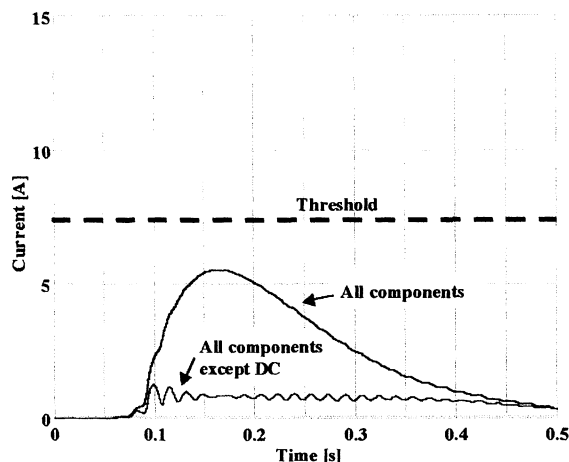

Figure 35. The RMS Value of Current Through the Relay during the Fault (all components and all components except DC)

## VI. CONCLUSIONS

IEEE published two documents on CT performance and application. This paper compares these documents and suggests modifications to make guidelines for CT selections easier and to provide more realistic results for CT transient behavior. This applies to both main and auxiliary CTs.

An example of transformer ground differential relay (GDR) misoperation during a three-phase fault because of improper auxiliary CT selection was presented. A comparative analysis to show how auxiliary CTs perform with characteristics selected from existing and proposed guidelines is demonstrated.

Presented methods for CT selection provide information if a CT will saturate, but do not provide the intensity of saturation. Therefore, even if a method indicates a CT will saturate, a computer study can determine the CT transient behavior and applicability for a particular protection scheme.

## References

- [1] C57.13-1993 ANSI /IEEE Standard, "Requirements For Instrument Transformers".
- [2] "Transient Response Of Current Transformers", Power System Relaying Report 76-Ch1130-4 PWR, IEEE Special Publication, 1976.
- [3] "Transient Response of Current Transformers", IEEE Power System Relaying Committee, IEEE Trans. on Power Apparatus and Systems, Vol. 96, No. 6, 1977.
- [4] IEEE Std C37.110-1996, "IEEE Guide for the Application of Current Transformers Used for Protective Relaying Purposes".
- [5] M. Kezunovic, Lj. A. Kojovic, C. W. Fromen, D. R. Sevcik, F. Phillips, "Experimental Evaluation of EMTF-Based Current Transformer Models for Protective Relay Transient Study", 93 WM 041-4 PWRD, IEEE/PES Winter Meeting, New York, 1993.
- [6] S. E. Zocholl, J. Roberts, G. Benmouyal, "Selecting CTs to Optimize Relay Performance", 23<sup>rd</sup> Annual Western Protective Relay Conference, October 15-17, Spokane, WA, 1996.
- [7] Lj. A. Kojovic, T. E. Wiedman, "Current Transformer Application Considerations for Protection in Grounded and Ungrounded Systems", American Power Conference, 57th Annual Meeting, Chicago, 1995.
- [8] Lj. A. Kojovic, N. A. Izquierdo, G. A. Grano, "Transient Characteristics of Auxiliary Current Transformers and their Influence on Industrial and Distribution System Protective Relaying", American Power Conference, 56th Annual Meeting, Chicago, 1994.

## Biography

**Ljubomir A. Kojovic** currently holds the position of Chief Power Systems Engineer for Cooper Power Systems at the Thomas A. Edison Technical Center in Franksville, Wisconsin. He has a Ph.D. degree in power systems with specialties in protective relaying, digital modeling, systems analysis, and testing. He is a Senior Member of the IEEE Power Engineering Society; is included in the roster of experts for United Nations Development Organization (UNIDO); and is a registered Professional Engineer in the State of Wisconsin. Dr. Kojovic has authored more than 100 technical papers.