**A New Approach to Current Differential
Protection for Transmission Lines**

**M. G. Adamiak
G. E. Alexander
GE Power Management
Malvern, PA**

**Dr. W. Premerlani
GE Corporate Research and Development
Schenectady, NY**

Presented to
**Twenty Fourth Annual
Western Protective Relay Conference
Spokane, Washington
October 22, 1996**

A New Approach to Current Differential Protection for Transmission Lines

M. G. Adamiak
G. E. Alexander
GE Power Management
Malvern, PA

W. Premerlani
GE Corporate Research and Development
Schenectady, NY

INTRODUCTION

This paper discusses a unique new approach to numerical current differential line protection that offers improved performance over the conventional percentage restraint approach. The current differential algorithm employs a new method of Fourier calculation that allows the protective system to use "partial" Fourier signals called "phaselets" rather than the normal fixed window Fourier approach. The phaselet approach also facilitates in the calculation of a confidence level for the measured currents. This permits the current differential system to adapt its operating characteristics based on the quality of the measured current values.

New adaptive approaches to pilot communications among the line terminals are also discussed. These new approaches permit the current differential system to dynamically adjust for changes in the transmission times between terminals, to account for different transmission times in each direction, and to provide redundancy in the case of partial loss of communications.

Finally, the paper discusses the design of the message used to transfer the data among the line terminals, the modulation techniques, and the physical interfaces to the communications media.

BASIC CURRENT DIFFERENTIAL RELAYING

Current differential relaying is applied to protect many elements of a power system. The simplest example of a current differential relaying scheme is shown in Figure 1. The protected element might be a length of circuit conductor, a generator winding, a bus section, etc. From Figure 1 it can be seen that current differential relaying is a basic application of Kirchhoff's Current

Law. The relay operates on the sum of the currents flowing in the CT secondaries, $I_1 + I_2$. For through current conditions, such as load or an external fault, the currents in the two CT's will be equal in magnitude and opposite in phase (assuming the CT's have the same ratio and are properly connected), and there will be no current flow in the relay operate coil [1].

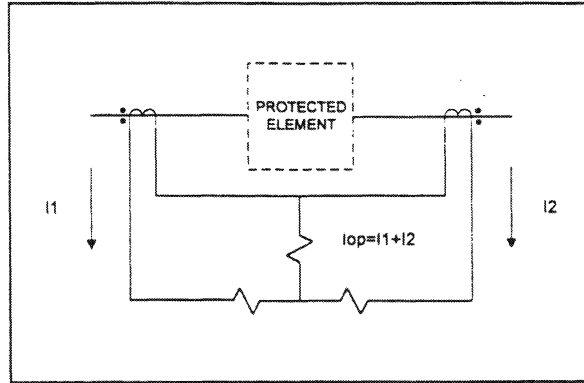

Figure 1

Should a short circuit occur within the protected section between the two CT's, current will flow through the operate circuit causing the relay to issue a trip output.

To improve the selectivity and security of the current differential scheme, it is often designed as a percentage restraint differential relay. In a percentage restraint current differential relay, the operating current is the vector sum of the CT currents.

$$I_{\text{operate}} = | I_1 + I_2 |$$

This operating current must be greater than the restraint quantity which is a percentage of the sum of the magnitude of the individual CT currents. A typical restraint current could be:

$$I_{\text{restraint}} = K * [| I_1 | + | I_2 |]$$

The operating characteristic of the percentage restraint current differential relay is shown in Figure 2.

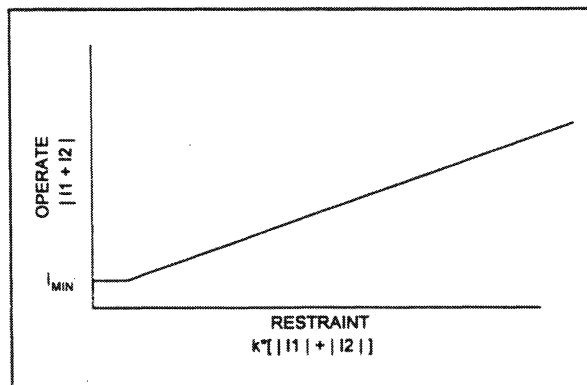

Figure 2

When a current differential relay is applied as unit protection within a station, for example on a transformer, or a generator, the current from all of the CTs can be run directly to the relay. However, when current differential relaying is applied to a transmission line, the CTs are physically separated, and it is not practical to connect the CT secondaries to the same relay. Therefore, in transmission line applications, a pilot communications channel is used to transfer current data between the substations. In such implementations, the pilot communications becomes an integral part of the protective relay

PHASELETS AND VARIABLE WINDOW FOURIER TRANSFORM

When a transmission line current differential relay is implemented in a digital design, there are two primary areas of concern. The first is the development of the current differential algorithm; the second is in the design of the data communications algorithm. The differential current may be developed from the sampled current values, or the sampled values may be processed by a digital filter such as the Discrete Fourier Transform. Use of sample data only, while dependable, decreases the security of the protection as bad or missing samples may result in a misoperation. The Fourier Transform, in conjunction with the confidence calculation discussed later, smoothes the data and can provide dynamic restraint for bad or missing samples.

The traditional approach to the calculation of the Fourier employs a “sliding data window” (typically a half or full cycle). When a fault occurs, the sliding data window includes pre-fault data along with fault data. Subsequently, the phasor estimation, (and the protective functions) will have an inherent transient time delay that is a function of the window size, as discussed in [2]. A traditional Fourier Transform using a sliding one cycle data window is shown in Figure 3A. With this approach, the magnitude of the output from the Fourier Transform does not equal the magnitude of the sampled waveform until the Fourier window includes a full cycle of fault data, as shown in Figure 3B.

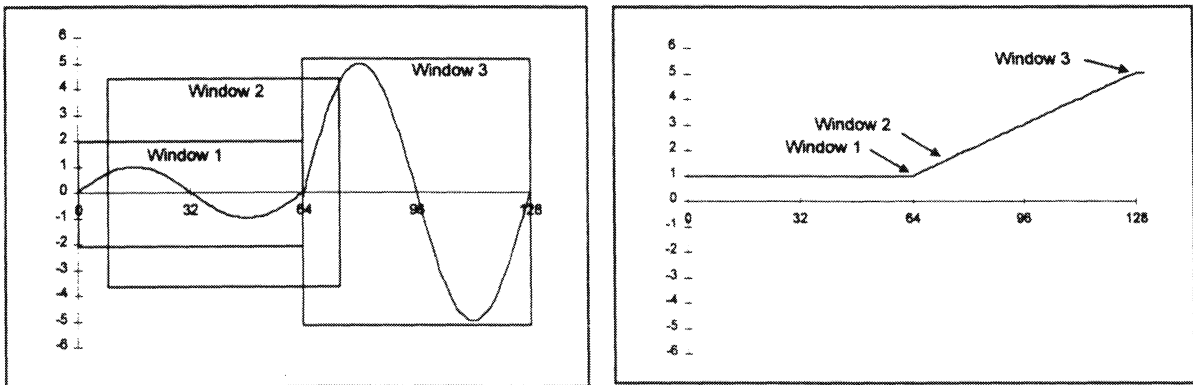

A. Fourier Windows

B. Magnitude Response

Figure 3 - Traditional One Cycle Fourier Window

A previous paper [3], introduced the concept of phaselets and the variable window Fourier transform as applied to distance type protection. The same approach may also be applied to a digital current differential relay. The concept of a “variable window” has been developed to improve the response of the phasor estimation, and as a direct result, to speed up the operating time of the distance relay.

Phaselets are partial sums of the product of the waveform samples and the sine/cosine coefficients. Groups of phaselets may be added together and transformed to create a phasor. Phaselets enable the efficient computation of phasors over sample windows that are not restricted to an integer multiple of a half cycle at the power system frequency. In the case of a data window that is a multiple of a half cycle, the computation is exactly equal to the Discrete Fourier Transform. In the case of a window that is not a multiple of a half-cycle, there is an additional correction that results from the sine and cosine functions not being orthogonal over such a window. However, the correction computation can be expressed as a two by two matrix multiplication of the sine and cosine weighted sums.

In steady state, non-fault, conditions, a one cycle window of data is used. The phaselets are summed over one cycle, creating the equivalent of a one cycle window DFT. When a disturbance is detected on the power system, the window size is dynamically reduced to the width of a single phaselet which includes only fault data. As new phaselets are obtained, the window size is increased to include the new data. Because all of the pre-fault data has been removed from the window, the phasor estimate responds more quickly to the state of the power system. The accuracy of the estimate improves as each new phaselet is added. The data window continues to expand until it reaches a full cycle at which point the window reverts to a sliding window similar to the conventional DFT. The variable Fourier window is depicted in Figure 4A.

The combination of the phaselets and the variable Fourier window allows the magnitude of the Fourier output to estimate the magnitude of the sampled waveform in much less than one cycle (Figure 4B). This in turn produces faster operating times for the protective relays.

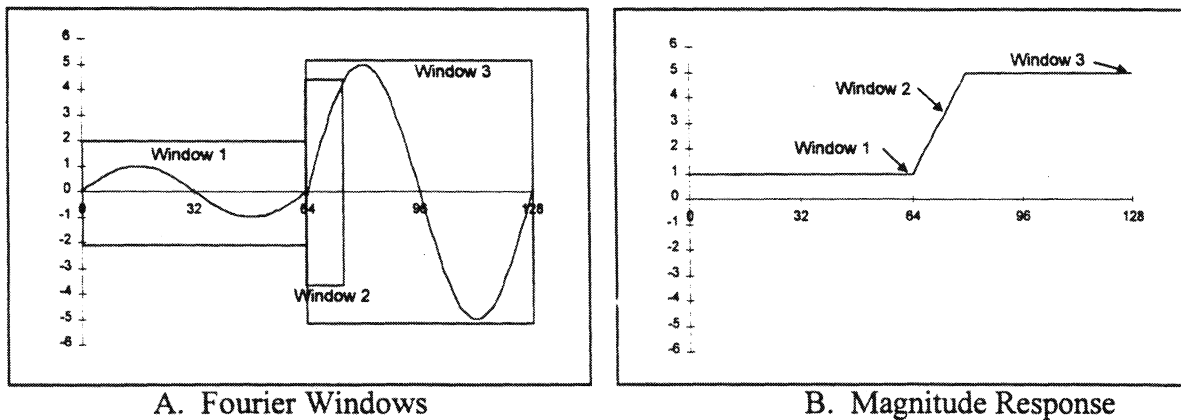

Figure 4 - Variable Width Fourier Window

RESTRAINT CHARACTERISTIC

The traditional percentage restraint characteristic shown in Figure 2 is commonly used in current differential relays; it may also be modified by the use of a dual slope restraint as shown in Figure 5. The dual slope percentage restraint characteristic improves the security of the current differential relay for faults external to the protected zone. This is of particular advantage because current transformers may not accurately reproduce the primary fault currents under transient fault conditions.

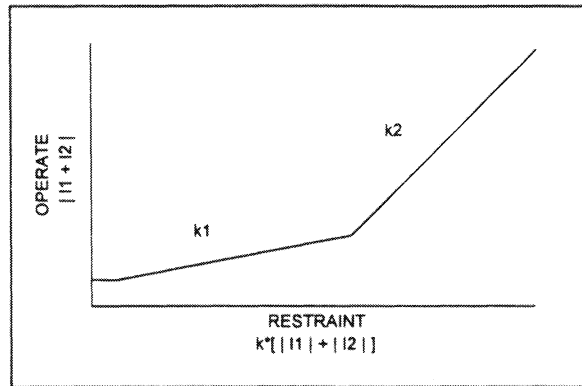

Figure 5

The dual slope restraint characteristic of Figure 5 is a form of adaptive restraint in which the magnitude of the restraint quantity is increased for high current conditions where CT accuracy is worse and CT saturation becomes more probable.

In a digital current differential relay it is possible to enhance the adaptive restraint concept beyond that of the dual slope characteristic. Consider the current waveforms of Figure 6. The dotted curve represents the actual current values measured by the relay; the smooth curve is the sine wave estimated from the Fourier Transform calculation.

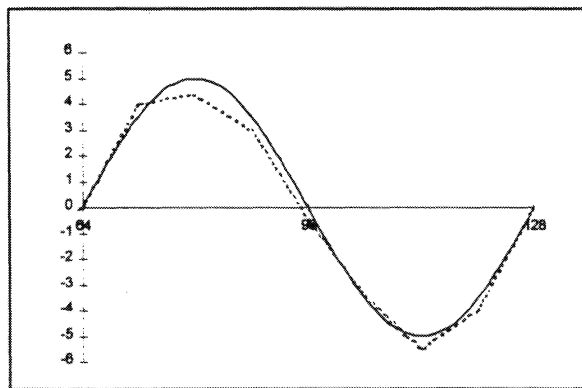

Figure 6

A least squares variance can be calculated from the difference between the actual and estimated data values. This variance is a measure of the "Goodness of Fit" of the Fourier estimation to the sampled data values. The deviation measurement can be used as a restraint signal. When the

waveform is distorted due to CT saturation, harmonic content, or fault initiation transients, the restraint due to the “Goodness of Fit” calculation will increase.

The variance, σ , can be calculated for any size data window, W , by the formula:

$$\sigma = \sqrt{\sum_{i=1}^W x_i^2 - (X_R \cdot PL_R + X_I \cdot PL_I)}$$

Where: σ = the "Goodness of Fit" error

x_i = the sample value at time i

X_R, X_I = real & imaginary phasor components

PL_R, PL_I = real & imaginary phaslet components

The percentage restraint characteristic of Figure 2 may also be mapped onto a complex current plane as depicted in Figure 7. In Figure 7, the operating current (I_{op}) is equal to $I_1 + I_2$, and the restraint current (I_r) is equal to $k \cdot [|I_1| + |I_2|]$ where k is the percent restraint. The magnitude of I_{op} must be greater than the magnitude of I_r for the relay to operate. This is true for both internal and external faults, and may desensitize the relay for high resistance internal faults with through load current.

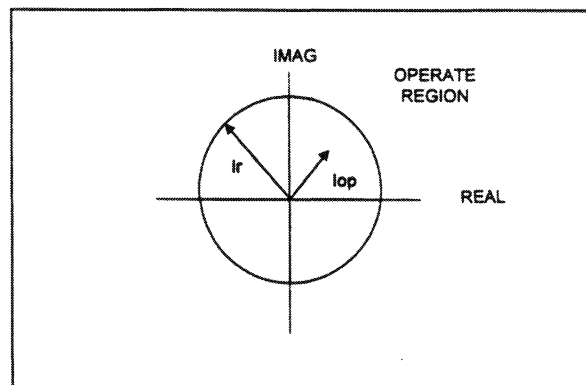

Figure 7

As an alternative to the fixed percentage restraint characteristic, an adaptive restraint based on the “Goodness of Fit” may be used to improve the sensitivity and security of the scheme. The adaptive restraint is dynamic and changes with the magnitude of the variance error measurement. The transients associated with fault inception generate a larger variance error and thus a larger restraint signal than during “steady state” fault conditions. The dynamic nature of the restraint is depicted in Figure 8. For the fault shown, the current differential scheme will not operate when the fault is applied because the restraint signal is larger than the operate signal; after the initial transients have decayed, the restraint will be reduced allowing the scheme to operate if required.

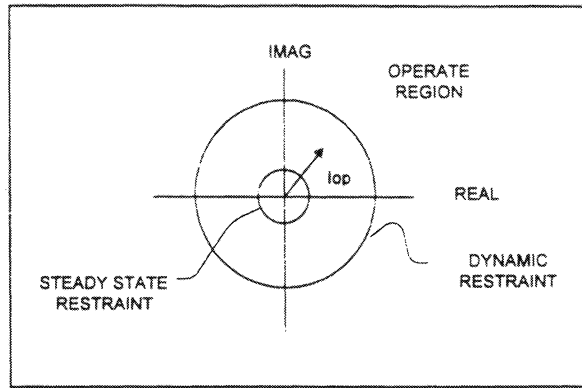

Figure 8

The shape of the error variance restraint characteristic is dynamic and is based on the position of the phasor calculation as related to the point on wave of the fault inception. As such, the characteristic can take on an elliptical shape based on whether the phase angle or magnitude is being more accurately measured. As an example, if the waveform is sampled near a zero crossing, the confidence in the phase angle measurement will be greater than the confidence in the magnitude estimate. If the waveform is sampled near the peak of the current waveform, the confidence in the magnitude estimate will be greater than the confidence in the phase angle estimate. The orientation of the ellipse will rotate depending on the incidence angle of the sampling.

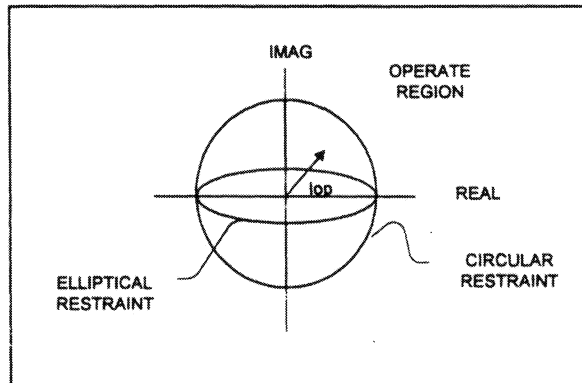

Figure 9

Improved coverage is possible with this scheme by reducing, or eliminating, the traditional percentage restraint setting. The improvement in the sensitivity of the protection is shown in Figure 9. In this condition, there is no loss of dependability as the restraint dynamically grows for questionable signals. It is also possible to combine the traditional percentage differential scheme with the adaptive restraint approach. This will allow an improvement in both security and dependability determined by user settings.

The net operating quantity for the current differential relay employing the proposed signals is:

$$\text{Operate} = C_1 \cdot X_R^2 + C_2 \cdot X_L^2 - K_1 \cdot C_3 \cdot \text{Restraint}^2 - C_4 \cdot X_R \cdot X_L - K_2 \cdot \sigma^2$$

Where:

The first two terms are analogous to the operate quantity of a conventional current differential relay.

The third term is analogous to the percentage restraint characteristic of a conventional current differential relay.

The third term determines the shape of the elliptical characteristic.

The last term is a measure of the “Goodness of Fit”.

C1-C4 are covariance terms.

K1 and K2 are constants.

The operate signal is effectively a measure of the distance from the operate signal to the restraint characteristic (balance point).

CLOCK SYNCHRONIZATION / PATH DELAY CORRECTION

One of the primary requirements of a current differential is that all the data used in the differential calculation be related in time. As such, there is a need to set and maintain very accurate clocks within the relay. There are two primary techniques that can be implemented to obtain this requirement. The first technique is to maintain a clock based on some external time source. The most widely available source that could be used is absolute time as available from the Global Positioning Satellite (GPS) system. Time accuracy of better than 1 usec is available from GPS clocks. Drawbacks with this technique are that additional hardware is required to implement the timing function and the long term availability is not guaranteed with this system as its primary function is military based.

An alternative synchronization technique that requires no additional hardware is the Internet technique known as “Ping Pong” [4]. Ping Pong relies on measuring the forward and return message communication times and using the measured time to properly correlate the received data with the local data. The communication delay time calculation is illustrated in figure 10. In its basic operation, relay 1 time tags and sends a message to relay 2 at time t_0 . Relay 2 receives the message at time t_1 , sets its time to the received time, and returns the message to relay 1 at time t_2 . Relay 1 receives the message at time t_3 and can now compute the assumed one way delay as:

$$t_f = t_r = (t_3 - t_0 - (t_2 - t_1)) / 2$$

A single calculation of the path delay by this formula would contain inaccuracies due to jitter in the communication channels. In order to minimize this jitter, literally hundreds of these Ping-Pong calculation are averaged together in order to bring the variance of the calculation down to the design requirement of 62 μsec .

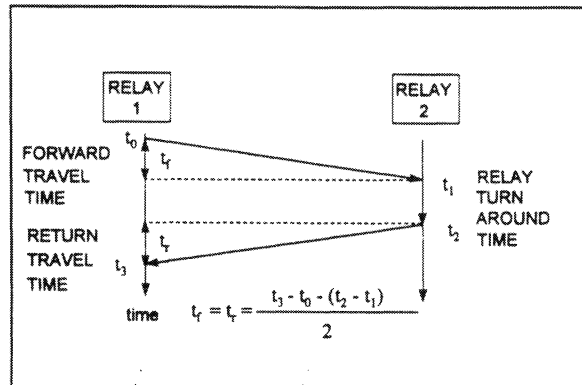

Figure 10

Note that the Ping-Pong technique necessitates the assumption that the forward time delay is equal to the return time delay. This assumption is not valid for the ensemble of communication solutions found in the utility environment. Unequal or “differential” time delay will tend to desensitize the relay as this time delay will result in an apparent phase angle difference (θ) between the measured currents at the end of each line (see figure 11). In order to improve the relay performance, this phase angle error is measured and then the clocks at each end are manipulated to correct for $\frac{1}{2}$ the phase angle error at each end. This correction is only possible on 2 and 3 terminal lines.

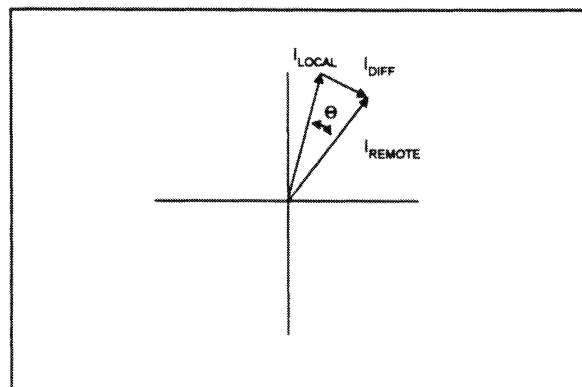

Figure 11

In addition to averaging numerous time measurements to determine the path delay, a mechanism is required to stabilize the clock when the system is communicating over a medium that can have a change in the path delay, such as a SONET ring, or a switched microwave system. Such a mechanism can be implemented through the use of a digital phase locked loop that tracks the phase of the load current signal using a long time constant. With this approach, when the path

delay changes, the clocks in the individual relays are held constant until the Ping-Pong algorithm has stabilized to the new path delays.

DATA COMMUNICATIONS

Historically current differential relaying has been applied using a wide variety of communications media ranging from dedicated pilot wires and FSK power line carrier to SONET and dedicated fiber optics. As mentioned previously, the performance of a current differential system is integrally related to the performance of its pilot communications channel. Performance criteria to consider in the design of the pilot channel for a digital current differential system include: media, bandwidth, signal-to-noise ratio, data efficiency, and data integrity. The optimization of these parameters will result in a data packet design that is flexible, and a physical channel interface that is adaptable.

There are three primary options for the physical interface to the pilot channel: direct dedicated fiber, high speed multiplexed digital channel, and leased line.

A direct dedicated fiber channel is clearly both the optimal performance and the highest cost option. The direct fiber connection poses no design constraints and offers the highest performance of the current differential scheme. Fiber optic transmitters are available that can span up to 100 km without need for a repeater. The bandwidth of the direct fiber allows the communications speed to be increased enabling the data packet to be transmitted quicker. This can result in relay operating times of less than one half cycle for per phase current differential schemes. With the inclusion of fibers in the ground wire in many newly constructed transmission lines, spare fiber pairs are often available for protection.

With the rapid development of fiber communications systems by both the electric and communications utilities, as well as the use of digital microwave networks, multiplexed digital channels are often available for use with transmission line protection. These channels are usually voice grade channels operating at 64 kbps with either an RS422 or G.703 physical interface. The bandwidth of this channel, combined with desired relay operating time of less than one half cycle for a per phase current differential scheme, limits the size of the transmitted data package to a maximum of 30 bytes of data. This packet must contain individual phase current measurements, signal quality data, Ping-Pong timing data, source address information, time stamp, control signals, and an error detection mechanism. In order to minimize the amount of data transmitted, a synchronous transmission protocol which saves about 40 bits of data is used. Because of the ability of this media to dynamically switch paths, it is possible to receive data which is out of time sequence with other received data packages. The inclusion of time information in the data package permits the data to be realigned in to the correct time sequence (Figure 12).

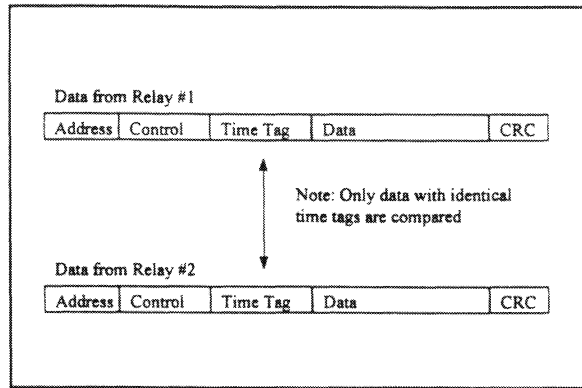

Figure 12

The third channel option, leased line, adds additional constraints to the data packet design. First, the available bandwidth decreases. A reasonable assumption for the bandwidth is about 14400 bps. With the reduction in channel speed, only one data packet can be transmitted per cycle; this will slow the operation of the current differential to about 2 cycles. In addition, the size of the packet must be reduced. As a result, per phase current information can not be transmitted; a combined current signal such as $I_2 - K I_1$, is used instead. Leased lines also present other problems: higher bit error rates and noise bursts. Some media of this type may exhibit bit error rates of 1 error every 10,000 bits; this is an error rate of 10^{-4} compared with 10^{-15} for fiber. The error detection algorithm used with the current differential system must be able to handle these rates. A 16 bit Cyclical Redundancy Code (CRC-16) has been evaluated and shown to have exceptional detection capability. The CRC-16 will detect all 1, 2, and 3 bit errors. With this CRC-16, the probability of a data packet containing an error going undetected is once every 300 years. When an error is detected, the suspect data is ignored and the current differential protection is blocked.

COMMUNICATIONS ARCHITECTURE

The relays in a current differential scheme can operate in one of two modes: Master or Remote. When the relay operates in the Master mode, it receives current information from all other relays on the line and performs the current differential calculation and makes all relevant trip and restraint decisions. When the relay operates in the Remote mode, it transmits current data, but does not receive current data from all of the other relays on the line. Because the relay does not receive current data from all line terminals, it can not perform the current differential calculation. A Master relay must perform the calculation and send a transfer trip command to the Remote relay(s) for internal faults. At least one relay on a transmission line must be a Master for the current differential scheme to function.

When the relays are applied on a two terminal line, a bi-directional communications path is required whether or not both relays are Masters. The loss of the communications channel will prevent proper operation of the current differential protection. One method to improve the overall

dependability of the current differential line protection is the use of redundant communications channels. This is depicted in Figure 13 for a two terminal line. In this scheme, data is continuously transmitted over both channels, but the relay uses only the data from Channel 1. If a failure is detected on Channel 1, the relays will automatically switch to Channel 2, and will continue to provide current differential protection.

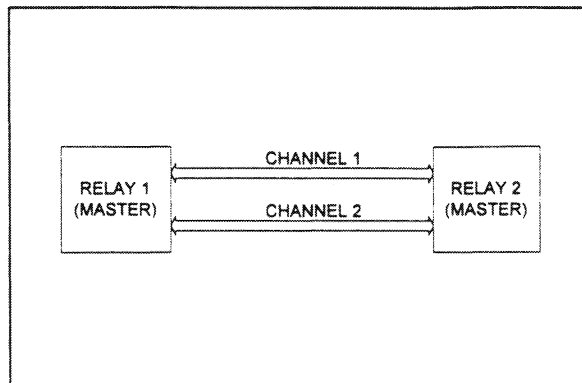

Figure 13

Figure 14 shows a typical current differential application on a three terminal line. In this application, each relay is exchanging current information with both remote terminals and all relays will operate in the Master mode. Dependability could be improved by adding redundant channels as was shown for the two terminal line application of Figure 13. However, this approach would incur the penalty of three additional bi-directional channels.

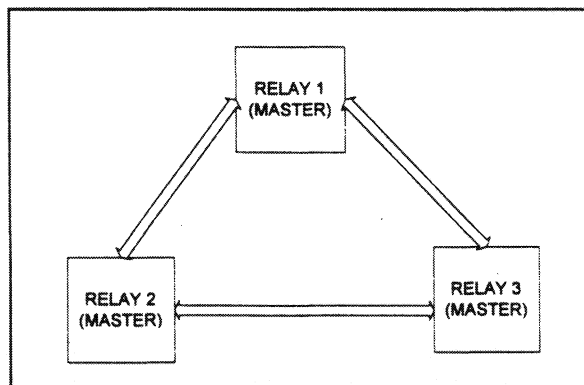

Figure 14

Another approach to improve the dependability is shown in Figure 15. When a channel fails, such as between terminal 2 and terminal 3, the relays with the failed channel will detect the failure and automatically change from the Master mode to the Remote mode. The relays at terminals 2 and 3 can no longer perform the current differential calculation because they do not have complete current information. The relay at terminal 1, however, is still receiving current data from both remote terminals and can therefore perform the current differential calculation. When the relay at terminal 1 determines that a fault has occurred on the protected line, it will trip the circuit breaker at terminal 1 and send a direct transfer trip signal to terminals 2 and 3.

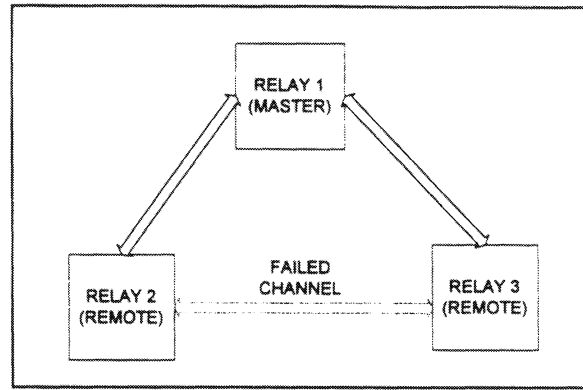

Figure 15

The communications methods discussed in this paper may be extended to a five terminal line, with all terminals operating in the Master mode as shown in Figure 16. A five terminal line application requires 9 bi-directional channels for all relays to be in the Master mode, but could function with as few as 4 channels in a Master- Remote mode.

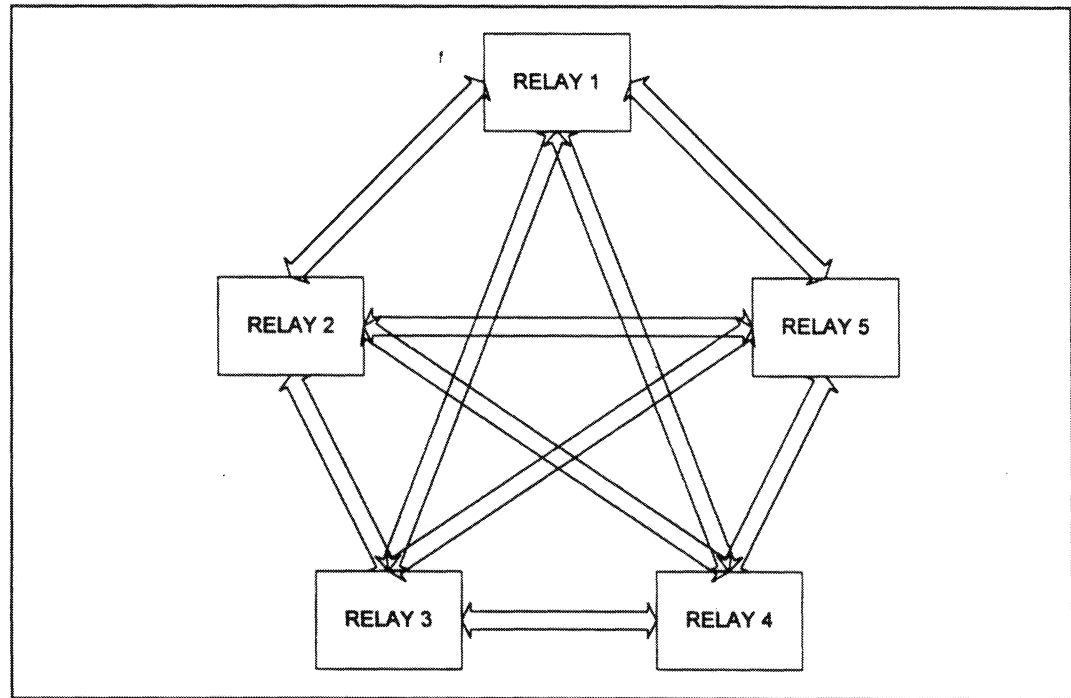

Figure 16

CHARGING CURRENT COMPENSATION

The basic premise for the operation of differential protection schemes in general is that the sum of the currents entering the protected zone is zero. In the case of a power system transmission line, that may not be entirely true because of the capacitive charging current of the line. For

short overhead transmission lines, the charging current can be treated as a small unknown error. In that case, the error due to the line charging current is covered by the percentage restraint characteristic of the current differential scheme. For long transmission lines and cables, the charging current may be too large to treat as an unknown error. In that case, it is often necessary to desensitize the current differential protection to prevent misoperations due to the line charging current (Figure 17).

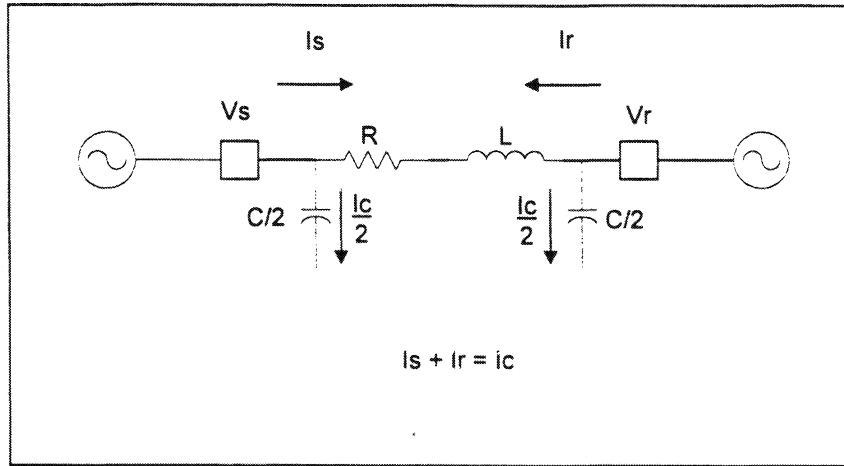

Figure 17

An adaptive approach for charging current compensation has been developed based on subtracting a $C \, dv/dt$ term from the measured current at each terminal of the protected line. This is a simple approach that provides adequate compensation of the capacitive current over the frequency range of the relay. The fine details of traveling waves on the transmission line are not compensated, and contribute to restraint by increasing the sum of the squares of the errors in the data samples. Apportioning the total capacitance among the terminals is not critical for compensation.

The three phase model at a terminal for charge compensation is shown in Figure 18. Both phase to phase and phase to ground capacitance is shown. The approximation is made that the system is balanced, so that the capacitance is the same for each phase. If there is a major unbalance in the charging capacitance, it may be desirable to model separate capacitance parameters for each phase.

C_{pg} is the phase to ground capacitance, C_{pp} is the phase to phase capacitance. In terms of zero sequence and positive sequence capacitance, C_{pg} and C_{pp} are given by $C_{pg} = C_0$ and $C_{pp} = 1/3 C_+ - 1/3 C_0$, where C_0 is the zero sequence capacitance and C_+ is the positive sequence capacitance. The compensation for each phase involves all three phases. For example, the compensation for phase a is given by $C_{pg} \cdot dV_a/dt + C_{pp} \cdot (2 \cdot dV_a/dt - dV_b/dt - dV_c/dt)$. Another, equivalent, expression for the charging current is $C_+ \cdot (dV_a/dt - dV_0/dt) + C_0 \cdot dV_0/dt$, where V_0 is the zero sequence voltage.

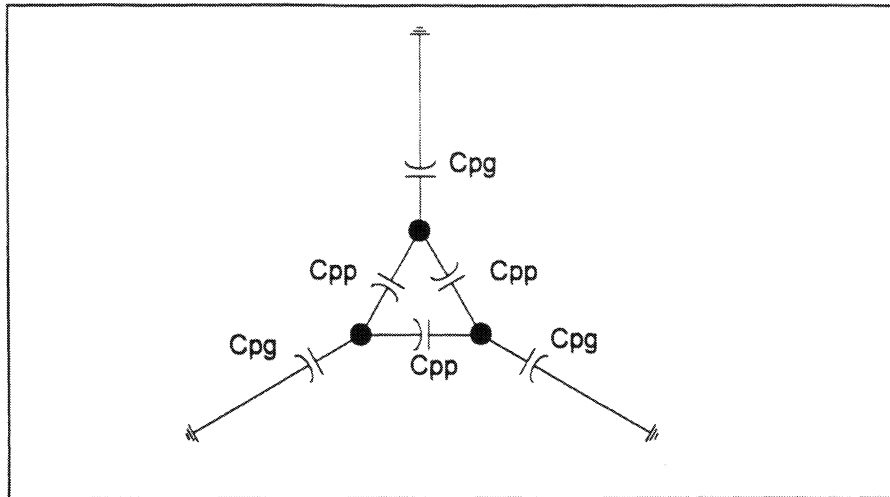

Figure 18

The compensation scheme continues to work with breakers open, provided voltages are measured on the line side of the breakers.

CONCLUSIONS

New techniques in the calculation of the Fourier transform in digital relays allow the relay to more quickly estimate the fault currents; this in turn improves the operating time of the relays.

In a digital implementation, the traditional percentage restraint current differential characteristic can be augmented, or replaced, with an adaptive restraint based on the variance between the sampled data and the Fourier estimate of the data.

Channel path delay errors can be reduced by compensating for different path delays in each direction, and dynamic changes in the channel delay can be accommodated.

The reliability of the current differential scheme can be improved by reducing the dependency of the scheme on the communications channel. This can be done by adding redundant channels, or by adapting the relay operation to the available channels by automatically converting from a Master to a Remote mode of operation.

REFERENCES

- [1] C. R. Mason, *The Art and Science of Protective Relaying*. New York: John Wiley and Sons, Inc., 605 Third Ave. NY, NY 10158 1956.
- [2] J. M. Kennedy and G. E. Alexander, " Variable Digital Filter Response Time in a Digital Distance Relay", *Twentieth Annual Western Protective Relaying Conference*, October 1993.
- [3] M. G. Adamiak, G. E. Alexander, and W. Premerlani, "Advancements in Adaptive Algorithms for Secure High Speed Distance Protection. ", *Twenty Third Annual Western Protective Relaying Conference*, October 1996.
- [4] D. L. Mills, "Internet Time Synchronization: The Network Time Protocol", *IEEE Transactions on Communications*. Vol. 39, No. 10, October 1991.