

current differential scheme working with limited bandwidth channels, while providing for high performance in terms of operation speed, sensitivity, and security under CT saturation and channel impairments.

II. REQUIREMENTS FOR NEXT GENERATION LINE CURRENT DIFFERENTIAL PROTECTION

Microprocessor-based line current differential schemes found their broad field applications only a decade or so ago. Many lessons have been learned from these first generation schemes. When looking forward at the next generation of line current differential schemes, the following requirements have been identified from a utility perspective.

A. High Performance

Advances in bus and transformer differential protection brought to life high-performance products. This pertains to speed of operation, sensitivity, and immunity to CT saturation. These improvements were possible because of the availability of high-performance microprocessors, high-speed sampling, optimum internal data buses, and new algorithms. Subcycle trip times became common, while requirements for CTs were considerably relaxed by the implementation of external fault detectors and better restraining techniques.

Equally high performance is expected from the next generation of line current differential relays.

B. Protection Security

Even though their application constantly broadens, line current differential schemes tend to be used on higher voltage, critical lines and those relatively shorter in length. Whether protecting lines carrying gigawatts of power in the expanding 765 kV network or protecting transmission lines connecting distributed generation, line current differential schemes must be exceptionally secure.

At least three areas affect the security of a line current differential scheme:

- The robustness of the relay hardware and firmware.
- The robustness of the applied algorithms and logic.
- The ability to deal with channel impairments and long fiber circuits.

The first two categories apply to any microprocessor-based relay. Manufacturers have developed significant knowledge in designing for relay and algorithm performance.

The latter category is specific to line current differential relays and relates to relay interaction with a communications network—a relatively complex system that is out of the control of relay designers and only partially under the control of the protection engineers at the user organization. Lessons learned in this respect should be incorporated in the next generation schemes, including unexpected channel asymmetry, channel switching, error detection capabilities, accidental loopback, accidental cross-connection of relays, and so on.

In addition, a modern relay should provide for recording or evidence-gathering capabilities to aid post-event analysis in areas related to communications impairments.

C. Channel Requirements

Both direct point-to-point fiber and multiplexed connections should be supported.

Direct point-to-point fiber can be made available for critical applications. In this respect, users expect relays to support longer distances. This allows the elimination of amplifiers along the fiber path and the related infrastructure (e.g., housing, redundant power supply, physical security perimeter, access roads, cybersecurity requirements).

Multiplexed connectivity is required for the majority of regular applications when direct fiber connections cannot be spared and instead only 64 kbps or a multiple thereof is made available for line current differential protection.

A modern relay should provide for redundant channel options at least in two-terminal applications. In particular, one channel may be a direct fiber connection, and the standby channel may be a multiplexed connection.

D. Charging Current Compensation

Line-charging current compensation is an expected feature of a modern line current differential relay.

In networks operated with a considerable unbalance, charging current compensation may be highly beneficial, even if using sequence differential elements, such as a negative-sequence differential element (87LQ).

In some 765 kV installations, the positive-sequence charging current is in the range of several hundred to over 1,000 A, and it may be higher than either the load or fault level.

E. Redefined Role of Backup Functions

Traditionally, a line current differential relay provides basic distance backup to cover cases of unavailability of the differential function because of problems with the communications channels. Typically, these distance functions are of a common design and slower speed and may face some performance issues.

A new trend has emerged that calls for a “line relay” rather than a line current differential relay, a full-featured distance relay, a distance backup relay, or a simple overcurrent backup relay.

In this concept, a multipurpose line relay is provided with the same form factor, wiring, and ordering/procurement, regardless of the served function. This allows a generic panel design and expands the standardization of panels, wiring, and substation integration, leading to reduced cost and shortened design and production cycles.

Functions of such a relay are still differentiated to allow for controlling the value and cost to the user.

In one aspect of this concept, there is little or no differentiation between a full-featured distance relay and a line current differential relay. The application may be decided late into the project, or it may change at some point in time, but the relay mounted in the panel is capable of providing both functions, even though not necessarily simultaneously. Some functions may only be operational when the communications are not in service.

F. Multiterminal Applications

A modern relay should provide protection for lines with more than three terminals. This need is driven by tapped loads or distributed generation tapped to transmission lines.

G. Auxiliary Functions

A modern relay should support modern and emerging functions in a variety of areas. This includes but is not limited to state-of-the-art Ethernet connectivity, synchrophasors, IEC 61850, secure point-to-point digital signaling, user-programmable math, customizable user interfaces, and cross-tripping.

The relay must also support current CIP (Critical Infrastructure Protection) requirements for passwords, security, and disturbance monitoring, including digital disturbance recorder (DDR), Sequential Events Recorder (SER), and digital fault recorder (DFR) requirements.

H. Single-Pole Tripping and Reclosing

We expect that under congested transmission, increased penetration of distributed generation, and the overall expansion of the North American power system, more and more transmission lines will be protected using the single-pole tripping and reclosing philosophy.

A modern line current differential relay should be capable of single-pole tripping and reclosing. This applies to tripping from the differential, as well as backup functions.

I. Self-Monitoring and Relay Maintenance

A new trend of extending maintenance intervals based on the amount of self-monitoring in microprocessor-based relays has gained momentum.

The concept supported by the emerging NERC (North American Electric Reliability Corporation) standards encourages relay manufacturers to quantify the extent and strength of self-monitoring in their microprocessor-based relays so that adaptive maintenance programs can be formally established at the user organizations.

As a logical consequence of this trend, the next generation relays should be designed with the ease of quantification of the embedded self-monitoring in mind and with the goal of making the self-monitoring as strong as possible without impacting the availability of the device. The ultimate goal is the option to “run to fail” with all relay failures being fail safe and detectable by the self-monitoring tests.

Line current differential schemes offer extra opportunities in this respect. Because multiple, independent relays constitute the protection system, data are shared and can be crosschecked between the relays in the differential system.

III. A TYPICAL LINE CURRENT DIFFERENTIAL SYSTEM

With reference to Fig. 1, the most distinctive feature of a line current differential protection system is that it consists of multiple relays operating independently and linked by a digital communications channel.

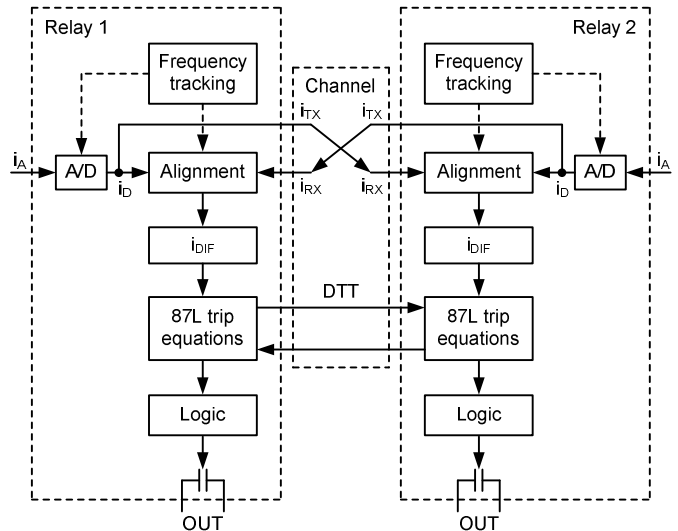

Fig. 1. Simplified architecture of a typical line current differential system.

The multiple relays in the system depend on each other in order to serve their purpose of providing the line current differential protection but are located at different substations and operate autonomously in terms of sampling, frequency tracking, transmission and reception of data, filtering, and protection calculations.

Each relay samples its analog input currents via an analog-to-digital (A/D) converter to obtain a digital representation (i_D) of the analog inputs (i_A). The sampling rate may vary from a few kilohertz to less than 20 samples per cycle, depending on the design. Typically, the same digital data feed the line current differential subsystem of the relay, as well as all the other local functions—metering, fault recording, and protection (distance backup, breaker failure, overcurrent, and so on). Therefore, the sampling is typically of high resolution and rate, even though the line current differential function may utilize these data at lower sampling rates.

The sampling may be performed at a constant rate or at a variable rate, tracking the power system frequency. The samples may be taken asynchronously with the local relay time or synchronously with the absolute time to simplify implementation of synchrophasor measurements.

Some implementations allow the relays in the differential system to sample asynchronously from each other, while some implementations use the communications channel to force synchronization of the relay sampling clocks.

To facilitate the line current differential function, the local current data must be communicated to the remote terminals ($i_{TX} \rightarrow i_{RX}$ in Fig. 1). Each relay that receives a full set of data from all its remote peers can align the data, run its differential trip equations, and operate autonomously in the so-called master mode. Each relay that only serves the data but does not receive all the remote data because of a permanent lack of communication (channel not installed) or a temporary loss of communication is referred to as working in the slave mode. Direct transfer tripping (DTT) from masters allows the slave relays to issue the trip command to their breakers.

Channels traditionally used for line current differential protection are limited in bandwidth (64 kbps is a typical value), and therefore only limited amounts of data can be exchanged between the relays at different line terminals. In this respect, various line current differential designs differ considerably.

Some relays exchange samples of currents, some relays work on phasors, and yet others work on nonconventional quantities such as a positive or negative current charge between consecutive zero crossings of the current.

This variety of approaches is driven by the substantial design challenge of conveying sufficient amounts of data to facilitate adequate protection performance, meeting channel bandwidth limitations, and providing for robust data synchronization, all at the same time.

When working with current samples, the system can collect and exchange samples at a rate that is high enough for accurate interpolation (e.g., 1 kHz). As a result, the design challenge of data synchronization can be met by measuring the data latency between the remote and local relays and interpolating (resampling) the remote current samples to align them with the local samples. While resampling, the relay can perform frequency tracking (i.e., take new virtual samples at the rate following the actual system frequency). As an extra advantage, the actual sampling clocks of the individual relays in the system do not have to be synchronized.

When working with phasors, the system faces a disadvantage that twice as much bandwidth is required to send the real and imaginary parts of the currents. As a result, the phasor exchange rate cannot be high enough to facilitate phasor interpolation, and the relay sampling clocks must be synchronized. This complicates the design, particularly in multiterminal applications where more than two relays need to stay synchronized. Also, in order to track system frequency, this kind of design must control relay sampling clocks with the concurrent goals of staying synchronized and following the power system frequency. Additionally, filtered phasors suppress high-fidelity information in the input currents, such as harmonics or rate of change of currents, making certain applications more difficult, such as in-line transformers or fast detection of CT saturation.

Data synchronization (alignment) is one of the key elements of a line current differential system. Commonly, a channel-based synchronization method known as a “ping-pong” algorithm is used to estimate clock offset between two relays working via a communications channel. This well-established timing method for communications networks measures a two-way travel time by time-stamping the sending and receiving of communications events and exchanging some of the time stamps. Assuming that the channel is symmetrical (meaning it is of the same latency in both directions), the total channel time can be recalculated into the clock offset between the two relays (see Section XI for more information). With the knowledge of this offset, the system is capable of aligning the data.

One method of alignment is to use the measured clock offset to control the local sampling time at both ends with the

goal to null out the offset, meaning to force synchronization of the two clocks. This approach works satisfactorily in two-terminal applications but becomes complex in multiterminal applications.

Another method is to time-stamp the transmitted data with the local time and, knowing the clock difference between the two relays, resample the data to align them to the same time instants. This method works naturally for any number of terminals as it allows each relay to freewheel without forcing a larger group of relays into relative synchronism.

The channel-based synchronization method works well if the channel is symmetrical. If the transmit and receive delays differ, the alignment becomes less accurate, leading to a phantom shift between the local and remote current measurements. Various protection algorithms have different immunity to such shifts if they are minor, but with major asymmetry, both dependability and security are impacted to the point of a complete loss of function.

In such cases, line current differential relays employ synchronization, if needed, based on an external time reference to augment or substitute for the channel-based synchronization. Until now, the Global Positioning System (GPS) has been the only practical way to provide for common timing across wide areas. Reliance on a satellite system and additional devices is not an ideal protection solution. Therefore, applications with symmetrical channels have been considered superior, while the need for GPS assistance has been considered the least preferred solution.

However, terrestrial systems are emerging for providing a common time reference [1]. These systems are synchronized to GPS—for the benefit of using true time under normal conditions—via multiple receivers located at multiple geographical locations but continue to provide common timing independently should all the GPS inputs be lost. These systems are a part of the communications infrastructure that is used for line current differential communications in the first place. Therefore, they are a safe means of providing for external time reference without introducing more devices, unnecessary interdependencies, or reduced reliability or availability.

There are two distinct communications channel applications for line current differential protection: dedicated point-to-point channels (typically fiber based) and multiplexed channels.

Dedicated point-to-point channels remove any third-party devices between the two communicating relays and, with them, all the associated failure modes. Such channels are inherently symmetrical, and any communications impairments are caused only by the relays themselves or the passive media between the relays.

As long-haul-dedicated channels are more expensive and are usually available only under special circumstances, multiplexed channels are used, typically within a SONET/SDH infrastructure. Multiplexed channels put third-party devices between the communicating relays with all their complexity, failure modes, and ride-through attempts often designed for nonprotection applications. This requires the line

current differential relays to be designed for a variety of failure modes caused by the active communications infrastructure between the relays.

This paper elaborates on a number of aspects briefly introduced in this section, while reviewing design directions for a new line current differential system.

IV. RELAY DESIGN CONSTRAINTS BECAUSE OF AVAILABLE CHANNEL BANDWIDTH

From the relay design perspective, the primary constraint of a microprocessor-based line current differential system is the requirement to work with a communications channel of a limited bandwidth.

Today, line current differential relays must work with 64 kbps channels. Even though direct point-to-point fiber connections allow bandwidths in the range of tens of megabits per second, and multiplexed channels can be requested with a bandwidth of $N \times 64$ kbps, the 64 kbps bandwidth continues to be a common application scenario.

To realize the amount of data that can be conveyed for protection purposes over a 64 kbps channel, let us assume a sampling rate of 16 samples per cycle and review the following:

- 64,000 bits per second =
- 1,067 bits per a 60 Hz power cycle =
- 267 bits per quarter of a 60 Hz power cycle =
- 66 bits per each of 16 sample sets in a 60 Hz power cycle

The 267 bits available every quarter of a cycle or 66 bits available 16 times a cycle may seem sufficient. However, as with any digital communications scheme, there is always certain overhead in the communications packet on top of the actual payload. In a line current differential system, the digitally encoded values of currents are the payload. The major components of the overhead include the following:

- A header is required to tell consecutive packets apart at the receiving end. A total of 15 bits may be needed.
- The integrity of the data must be protected by redundancy checks such as Bose, Ray-Chaudhuri, Hocquenghem (BCH) Code or Cyclic Redundancy Code (CRC). A total of 32 bits is typically needed.
- Channel-based synchronization methods need to append certain time values to the packet. A total of 16 bits or more may be required.
- The packet must support basic addressing to prevent accidental cross-connection of line differential relays. A total of 4 to 8 bits may be required for basic addressing.
- DTT and other flags must be supported. A total of 4 to 8 bits may be used for this purpose.

The above can add 50 to 80 bits of overhead.

Note that when sending packets 16 times a 60 Hz power cycle over a 64 kbps channel, we can only use 66 bits, having practically no room for payload even when significantly optimizing the payload and the overhead.

Still, when designing relays for high-speed operation, it is beneficial to keep the rate at which fresh data are passed from subsystem to subsystem high so that the total data latency is minimized. Therefore, it is advantageous to exchange the analog data between line current differential terminals multiple times per cycle.

As shown by our simple calculations, the task of passing the right data at a high rate is not trivial. It is clear that the protection-driven payload and the communications-driven constraints must be addressed in a concurrent design in order to yield a high-performance scheme. It is very important which quantities are sent, how often, and how they are encoded, packetized, and protected for integrity.

When moving data within a single relay using internal data buses designed adequately, we do not have to apply as much optimization. When working with a low-bandwidth channel in a line current differential system, however, an important part of protection design is to select protection algorithms that maximize the available bandwidth.

In general, the following solutions aid the design:

- Smart encoding. Properties of the sent data, if studied carefully, may allow reducing the number of bits required to convey their values. For example, a negative-sequence restraint can be sent as per unit of the highest phase current restraint. Or the value of current can be encoded on a log-based scale rather than a linear scale to recognize the wide range of current signals.
- Interleaving, or sending small fragments of slowly changing data in consecutive packets. For example, the channel-based synchronization calculations can be run at a rate lower than the packet rate.
- Sending various pieces of data at optimum rates required by the applied protection equations.
- Increasing the packet size so that the payload-to-overhead ratio becomes more favorable.
- Selecting the payload in a way that maximizes the information content in it, given the intended protection algorithms.

In order to illustrate the concept, consider the packet and protection equations presented in this paper. This solution works with 1 kHz samples of currents and utilizes proven Alpha Plane protection equations [2].

Table I summarizes the packet content.

TABLE I
PACKET PAYLOAD DEFINITION

Symbol	Meaning
$i_{A(k)}$	Present (k-th) sample of the line current, A-phase
$i_{A(k-1)}$	k-1 sample of the line current, A-phase
$i_{A(k-2)}$	k-2 sample of the line current, A-phase
$i_{B(k)}$	As above, B-phase
$i_{B(k-1)}$	
$i_{B(k-2)}$	
$i_{C(k)}$	As above, C-phase
$i_{C(k-1)}$	
$i_{C(k-2)}$	
I_{AR}	Restraint term, A-phase
I_{BR}	Restraint term, B-phase
I_{CR}	Restraint term, C-phase
I_{QR}	Negative-sequence restraint term
I_{GR}	Zero-sequence (3I0) restraint term

The payload of Table I can be encoded using slightly more than 100 bits, allowing us to send packets every 3 milliseconds (3 milliseconds at 64 kbps allows 192 bits).

The following sections of this paper explain in detail how the individual data items in the packet are calculated prior to transmission and consumed upon reception. In short, the instantaneous values are total line currents at the sending terminal (a sum of all the local currents, such as from the two breakers of a dual-breaker termination), while the restraint terms are sums of magnitudes of all the local currents (such as from the two breakers of a dual-breaker termination). Simply put, the instantaneous values are partial line differential currents, and the restraint terms are partial line restraint currents.

The selected payload provides the following benefits:

- Fresh data are sent every 3 milliseconds, or more than five times a 60 Hz cycle, minimizing latencies and speeding up operation of the relay.
- A packet lost just before or during an internal fault erases only 3 milliseconds of data, allowing for fast recovery and preventing delayed operation of the relay.
- Working with 1 kHz samples offers good fidelity of differential current measurements and allows the calculating of harmonics for in-line transformer applications and fast detection of saturated CTs.
- Sending three samples of instantaneous current per packet improves the payload-to-overhead ratio.
- Sending one value of a restraint per packet (or per three samples of instantaneous values) reduces bandwidth requirements, while it is sufficient for protection applications.

- Restraint quantities are magnitudes that can be encoded using fewer bits. In addition, the restraint quantities are auxiliary terms and can be encoded with lower accuracy without sacrificing security.
- The five restraint terms can be interleaved, saving extra communications bandwidth.
- The negative- and zero-sequence restraint terms can be encoded as per-unit values with respect to the highest phase restraint, further reducing the bandwidth requirement.
- The packet format makes the solution scalable, as it works with any number of local currents at a given line terminal. The packet always contains the partial differential and partial restraint terms.

The following sections explain how this packet format enables fast detection of saturated CTs, provides for proper restraint in dual-breaker applications, and supports line-charging current compensation and protection of in-line power transformers.

V. DUAL-BREAKER TERMINALS AND PROTECTION SECURITY

A. Introduction

Dual breaker refers to a line configuration where the line is terminated in a double-bus double-breaker, breaker-and-a-half, or ring-bus substation (Fig. 2). Modern line protection relays support two three-phase sets of current inputs and measure the two currents independently. These relays work with the internally summed current for the main protection function—distance, ground directional overcurrent in a pilot-assisted scheme, or the line current differential. At the same time, it provides for two independent breaker failure functions, two independent autoreclosers, metering, recording, and time-coordinated backup, all responding to the individual breaker currents.

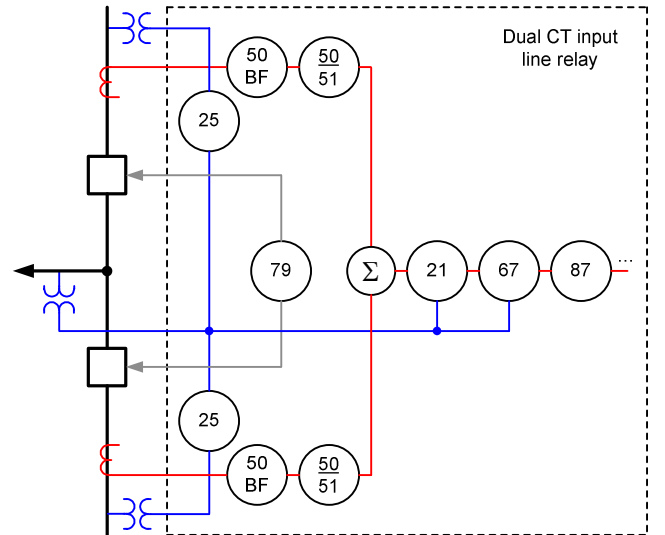

Fig. 2. Dual-breaker line termination and application of dual CT input relays.

As a result, dual CT input line relays enable a complete protection, metering, monitoring, and fault recording solution for dual-breaker line terminals.

Dual-breaker applications working with breaker currents may create some protection challenges.

First, the two CTs may be rated much higher as compared with the load of the protected line, challenging protection sensitivity and calling for low settings compared with the CT secondary values.

Second, a through fault across the two breakers may challenge protection security, particularly if the remote line terminals are weak and/or the applied settings are sensitive.

With reference to Fig. 3, an external fault below CT-2 draws a fault current from the local system via CT-1 and from the remote terminal(s) via the protected line. The local relay responds to the internally summed i_{CT-1} and i_{CT-2} currents ($i_{L(MEAS)}$). With no CT errors, this virtual current is the line current at the local terminal. When considering CT errors, however, this current is measured with a finite accuracy as compared to the real line current ($i_{L(TRUE)}$).

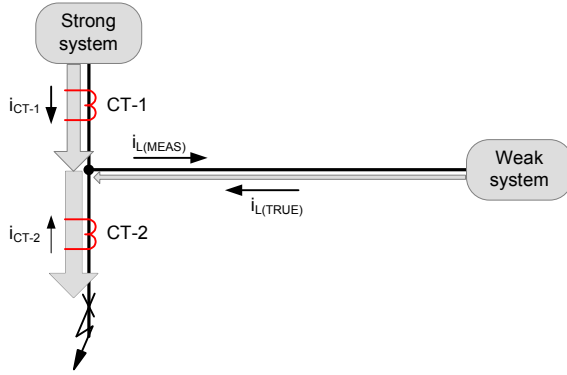

Fig. 3. A through-fault scenario challenging protection security of a dual-breaker line application.

If the fault current is high and the CT carrying the current away from the line terminal saturates (CT-2, in this case), enough error can develop in the measured line current, and its direction may be reversed with respect to the true current, especially if the true current is low because the remote line terminal(s) are relatively weak.

Close-in reverse faults depress the voltages, while CT errors can reverse the measured line current. With enough CT saturation, any line protection method can be defeated in this situation: distance, ground directional overcurrent, line current differential, phase comparison, and so on, unless the relay design and/or the application logic address the issue explicitly.

Ground (zero-sequence) and negative-sequence elements are particularly vulnerable during faults that do not produce a sequence component in the primary currents (three-phase symmetrical faults and line-to-line faults for ground elements, and three-phase faults for negative-sequence elements). Under these fault conditions, the true primary sequence current is zero, but a CT error will generate a secondary sequence current.

This paper is concerned with the phase (87LP), ground (87LG), and negative-sequence (87LQ) line current

differential functions. Two approaches are used independently and simultaneously in order to secure these functions.

First, the notion of a through-fault current is developed via proper restraint terms. These terms are inserted into the communications packet, utilizing a minimum possible bandwidth. The restraints are not used directly for tripping but feed into generalized Alpha Plane trip equations (see Section VII).

Second, an external fault detection logic is implemented to signal the occurrence of an external fault and increase security beyond the natural level provided by the restraint terms.

B. Partial Differential and Restraint Terms

Consider the three-terminal line configuration of Fig. 4, with each line end terminated as a dual-breaker connection.

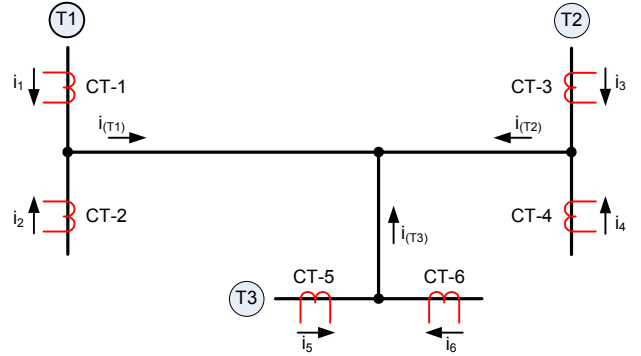

Fig. 4. Sample three-terminal, dual-breaker line configuration.

In the proposed design, each relay calculates its partial differential and partial restraint term as follows:

$$i_{A(T1)} = i_{1A} + i_{2A} \quad (1a)$$

$$i_{B(T1)} = i_{1B} + i_{2B} \quad (1b)$$

$$i_{C(T1)} = i_{1C} + i_{2C} \quad (1c)$$

$$I_{AR(T1)} = I_{1A} + I_{2A} \quad (2a)$$

$$I_{BR(T1)} = I_{1B} + I_{2B} \quad (2b)$$

$$I_{CR(T1)} = I_{1C} + I_{2C} \quad (2c)$$

$$I_{QR(T1)} = I_{1Q} + I_{2Q} \quad (3a)$$

$$I_{GR(T1)} = I_{1G} + I_{2G} \quad (3b)$$

where lowercase symbols stand for instantaneous values, and uppercase symbols denote magnitudes.

Similar terms are calculated for Terminals T2 and T3.

If required, CT ratio matching between the local CTs and remote CTs of the protected line is performed prior to the calculations.

The above quantities constitute the core protection payload per Table I. Each terminal calculates its partial terms and sends them to its peers.

Assume now that an external fault occurs at the T1 terminal. Under CT saturation, the partial differential current sent by this terminal may have a considerable error in it. However, at the same time, this terminal sends a restraint term

that reflects the external fault current, feeding the Alpha Plane trip equations with information to counterbalance the errors in the differential signal.

Upon receiving and aligning all the partial terms, each relay calculates the total line differential and restraint currents for the 87LP function (A-phase is shown; B- and C-phases are similar):

$$i_{ADIF} = i_{A(T1)} + i_{A(T2)} + i_{A(T3)} = \dots \quad (4)$$

$$\dots = i_{1A} + i_{2A} + i_{3A} + i_{4A} + i_{5A} + i_{6A}$$

$$I_{ARST} = I_{AR(T1)} + I_{AR(T2)} + I_{AR(T3)} = \dots \quad (5)$$

$$\dots = I_{1A} + I_{2A} + I_{3A} + I_{4A} + I_{5A} + I_{6A}$$

and for the 87LQ and 87LG functions:

$$I_{QRST} = I_{QR(T1)} + I_{QR(T2)} + I_{QR(T3)} = \dots \quad (6)$$

$$\dots = I_{1Q} + I_{2Q} + I_{3Q} + I_{4Q} + I_{5Q} + I_{6Q}$$

$$I_{GRST} = I_{GR(T1)} + I_{GR(T2)} + I_{GR(T3)} = \dots \quad (7)$$

$$\dots = I_{1G} + I_{2G} + I_{3G} + I_{4G} + I_{5G} + I_{6G}$$

In this way, each relay in the line current differential system derives the true value of the restraint current, regardless of the location of the fault and the short-circuit capacity behind any given relay. For example, the T3 terminal may be very weak, therefore producing very little restraint for a fault at T1. However, it will receive the T1 partial restraint values to counterbalance possible errors in the T1 partial differential current.

Note that the proposed design is scalable and works with any number of local currents without the need to modify the communications package or increase the bandwidth. The other local currents can be line reactor currents, calculated line-charging currents, or currents of a small bus included in the line protection zone, as long as the relay hardware supports extra current inputs.

The line differential and restraint currents feed into generalized Alpha Plane trip equations, as explained in Section VII.

C. External Fault Detection Logic

In addition to relying on natural levels of restraint, the solution described in this paper incorporates an explicit external fault detection (EFD) logic with the intent to increase security further during external faults and relax the CT requirements and related engineering effort of verifying the CTs.

Fig. 5 presents the EFD logic. This method is successfully used in bus and transformer differential relays [3] [4]. An increase in the instantaneous restraining signal (above the threshold P) without a similar increase in the differential current (multiplier q) signifies an external fault. The dropout timer (DPO) ensures security throughout the fault duration.

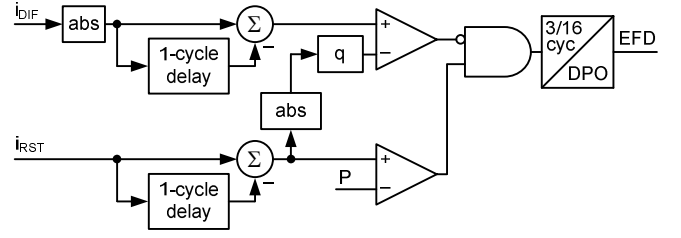

Fig. 5. External fault detection logic.

A simplistic implementation of this method would require instantaneous values of all the currents of the line differential zone to be communicated between the relays. This requirement is not practical and has been overcome as follows.

Each terminal uses (8) to derive its own instantaneous restraining current based on its local currents and the partial differential terms from the remote terminals (refer to Fig. 4; the phase index—A, B, or C—is omitted).

$$i_{RST(T1)} = |i_1| + |i_2| + |i_{(T2)}| + |i_{(T3)}| \quad (8a)$$

$$i_{RST(T2)} = |i_3| + |i_4| + |i_{(T1)}| + |i_{(T3)}| \quad (8b)$$

$$i_{RST(T3)} = |i_5| + |i_6| + |i_{(T1)}| + |i_{(T2)}| \quad (8c)$$

where $|x|$ stands for the absolute value of an instantaneous signal x .

The above terms are not communicated between the relays but used locally. Each relay executes the logic of Fig. 5 using its instantaneous local restraint (8) and the line differential current (4).

The relay at the terminal with an external fault is guaranteed to detect the fault because it measures the through-fault current. The other relays may or may not detect the fault, depending on the current flow between the terminals. If a given terminal is weak, it may not detect the external fault located at the remote strong terminal.

Therefore, the EFD flag derived locally is added to the communications payload and consolidated with the other terminals upon reception, as shown in Fig. 6.

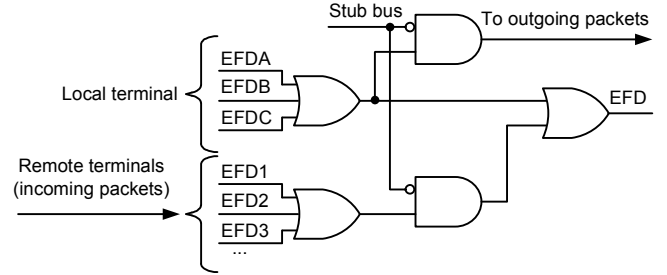

Fig. 6. Consolidating EFD flags between phases and line terminals.

In this way, all the relays work with the same amount of information, and all behave correctly. A weak terminal, T3 for example, may receive an incorrect value of the partial differential current from T1 because of an external fault at T1 and considerable CT saturation. On its own, the T3 terminal may not be able to detect the event as an external fault, but it receives the EFD flag from the T1 terminal informing it

explicitly about the external fault. As a result, a differential term in any given packet with a potential error because of an external fault and CT saturation is always accompanied by the EFD flag and an elevated restraint term. In our example, the T3 terminal is fully prepared to deal with the event at T1, even though it does not have any direct visibility into this event (i.e., it does not measure the i_1 and i_2 currents directly).

Fig. 7 presents a simulation example illustrating the restraint terms and the EFD logic. The terminal with the external AB fault asserts the EFD flag safely before CT saturation impacts accuracy and produces considerable errors in the A-phase current sent by this terminal. Note that the restraint term in the A-phase is considerable, already stabilizing the 87LP function.

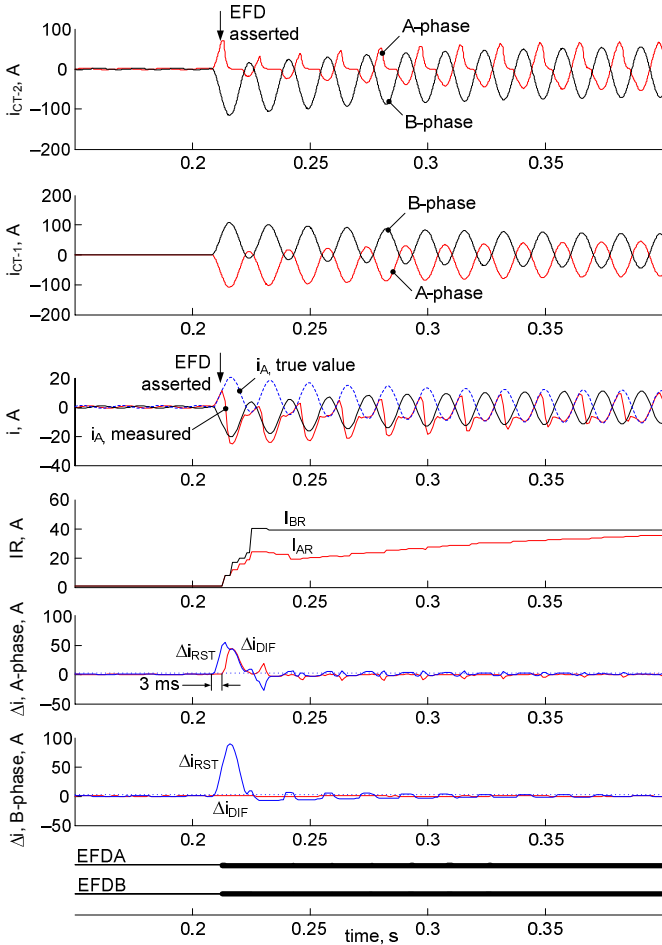

Fig. 7. Critical signals at the dual-breaker terminal for an external AB fault: currents across the two breakers, partial differential current (measured and actual), partial restraint, delta changes in differential and restraint currents and the EFD flags.

The described logic delivers similar performance to that of a modern, low-impedance bus or transformer relay. It is capable of detecting external faults even if considerably underrated CTs are installed. As long as the CTs perform with no or only minor errors in the first 3 milliseconds of an external fault, the logic works correctly. This level of performance is achieved at the expense of adding just 1 bit to the communications payload.

The EFD logic is scalable and works seamlessly with any number of local currents at any given terminal without the need to modify or expand the packet.

Upon asserting the EFD flag, the relay increases security by intentionally raising its natural restraint terms. This may include harmonic restraint—adding harmonics in the differential current to the restraint or adding a portion of the phase restraints to the negative- and zero-sequence restraint terms to secure these elements under external faults that do not produce any natural sequence restraint. The intentionally amplified auxiliary restraint term feeds into the Alpha Plane trip equations as explained, further increasing protection security.

VI. MULTITERMINAL LINE APPLICATIONS

Line current differential relays have been primarily designed to cover two- and three-terminal line applications. Typically, two communications ports are provided on a relay. These ports can be used to communicate with two remote relays in a nonredundant way, allowing for a three-terminal line application. Or the two ports can be used for redundant communication between two relays in a two-terminal application.

Recently, reasons to provide for more than three-terminal line applications became more compelling.

Some utilities tap subtransmission and transmission lines to feed distribution stations and larger industrial loads. In some cases, five taps can be encountered, constituting a seven-terminal application. Instantaneous fault clearing in such cases is typically accomplished using distance protection in a pilot-assisted scheme, with the pilot installed only between the two stations. The distance functions are set to overreach the far-end bus but set short of the low-voltage buses of the tapped transformers. This setting rule may be difficult to meet for longer lines and/or when a large transformer is located close to one of the substations. In such cases, extra pilot channels may be required between some of the taps and the main terminals to allow explicit blocking for faults in the lower voltage system.

The application is usually complicated. The line current differential protection principle is a better alternative for lines with multiple taps. With a constantly progressing deployment of digital communications channels and advancements in relay design, line current differential schemes became more readily available.

More recently, distributed generation has been tapped into subtransmission or transmission lines the same way loads used to be tapped. This poses an even greater challenge, as the short-circuit response of these nontraditional sources may cause problems or uncertainty for traditional protection principles. These sources often include power electronics with fast controllers designed to provide a low-voltage ride-through capability or just protect the source itself from damage. Protection engineers struggle with modeling these generators for short-circuit studies, and as a result, some level of uncertainty remains in these applications.

Because lines tapping new generation are essential to having the generation available in the first place, they may apply single-pole tripping and reclosing. This complicates protection applications further.

Very often, however, lines connecting distributed generation have digital communications channels available. Line current differential protection is a natural solution in this case, eliminating complexity and uncertainty related to the behavior of nontraditional sources, while reducing the danger of overtripping and increasing availability of the added generation.

In order to provide multiterminal (N-terminal) line current differential protection, a differential relay must first resolve the following issues:

- Consolidation of all the terminal currents for protection calculations.
- Connectivity between N terminals.
- Synchronization between N terminals, given their actual connectivity pattern.

The solution outlined earlier in this paper of sending partial differential and partial restraint terms from each relay solves the first problem. Regardless of the number of local currents at each line terminal (single breaker, dual breaker, small bus), the same optimized packet conveys all the information required to provide a high-performance line current differential function. The next section explains how the Alpha Plane principle is applied to an arbitrary number of terminals.

Another challenge is the connectivity between N terminals. Direct point-to-point connections require each relay to support $N - 1$ communications ports for exchange of data with all its peers (e.g., six ports for a seven-terminal application). This increases the relay part count and, as a result, impacts cost, availability, and reliability.

In addition, the user needs to provide a number of point-to-point connections: 1 channel for 2 terminals, 3 for 3 terminals, 6 for 4 terminals, 9 for 5 terminals, and so on. This of course assumes all relays are masters. A hybrid solution allows some relays to be slaves (i.e., only serve the data) with a few other relays being masters capable of receiving all the data, asserting a trip, and sending it via DTT to the slaves. This reduces the number of required connections, at the cost of slowing down the operation.

Channel-based synchronization may be an even greater challenge, depending on the method applied. Solutions that force synchronization of relay sampling clocks face more difficulties.

The challenge of connectivity and data synchronization is easy to solve from the point of view of a modern communications system such as SONET/SDH. Recently, these communications systems have provided for deterministic transport mechanisms, including “deterministic Ethernet” for protection applications as well as common timing with the capacity of being a GPS-independent common time source [1].

In this solution, the external time reference synchronization method is used (see Section XI), while deterministic Ethernet with guaranteed bandwidth and latency becomes the data transport mechanism (Fig. 8). In a way, the next generation SONET/SDH built for utility applications, including protection and synchrophasors, becomes a part of the line current differential system. This is a simple and robust solution for N-terminal line current differential relaying because of the following:

- The SONET/SDH network is entirely under the control of the user. It can be deployed and configured for redundancy and is operated and maintained as a protection-grade system.
- The common time reference provided by the system is independent from GPS. Even if all dispersed receivers are lost, the system maintains common time across the wide area.
- With the SONET/SDH deterministic communications backbone, a portion of Ethernet traffic is isolated for deterministic delivery across a wide area. In this way, Ethernet is more of a connectivity media between the line current differential relays and the multiplexers, while the actual transport is rigorously controlled by the next generation SONET, using its deterministic backbone.
- Using the same system for timing and data transport improves reliability by reducing the total number of devices and associated failure modes.

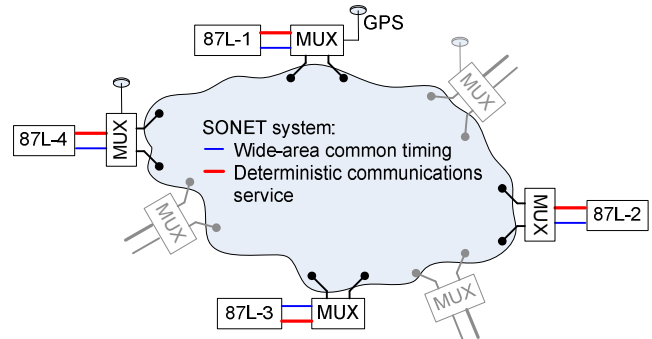

Fig. 8. Multiterminal line current differential application with next generation SONET/SDH systems.

Multiterminal line current differential applications can be implemented in a simple and robust way by utilizing a next generation SONET/SDH system and tasking it with providing a common wide-area time reference independent from GPS and deterministic Ethernet connectivity in the relay-multiplexer-fiber-multiplexer-relay path.

significant, will be approximately located along the line of the fault current. Therefore, by selecting the reference current I_p that is closest in phase to the differential current, we position the two equivalent Alpha Plane currents along the lines of the current flowing in and out of the zone.

To select the reference current I_p , the following auxiliary numbers are calculated first:

$$R_n = \left| \text{real} \left(I_n \cdot I_{\text{DIF}(N)}^* \right) \right| \quad (11)$$

where $n = 1..N$.

The current with the highest value of R becomes the reference current I_p .

Let us denote the angle of this current as β :

$$\beta = \text{angle} \left(I_p \right) \quad (12)$$

The differential current is shifted for the convenience of subsequent calculations as follows:

$$I_X = I_{\text{DIF}(N)} \cdot 1 \angle (-\beta) \quad (13)$$

And the two currents of the two-terminal equivalent are now calculated as follows:

$$I_{L\text{EQ}} = \left(\frac{\text{Im}(I_X)^2 - \left(I_{\text{RST}(N)} - \text{Re}(I_X) \right)^2}{2 \cdot \left(I_{\text{RST}(N)} - \text{Re}(I_X) \right)} + j \cdot \text{Im}(I_X) \right) \cdot 1 \angle \beta \quad (14a)$$

$$I_{R\text{EQ}} = \left(I_{\text{RST}(N)} - |I_{L\text{EQ}}| \right) \cdot 1 \angle \beta \quad (14b)$$

The traditional Alpha Plane protection principle takes over from here, working with the $I_{L\text{EQ}}$ and $I_{R\text{EQ}}$ currents.

The classical differential principle has been used in this method as a mathematical mapping tool to project the general case of an N -terminal differential zone into an equivalent two-terminal zone, requiring the differential and restraining currents be identical between the N -terminal application and its two-terminal equivalent.

The principle is applied to the phase, negative-sequence, and ground differential elements with the filtered differential and restraint currents obtained via (4) through (7) from the partial terms communicated between the relays.

C. Numerical Examples

1) Example 1

Consider the following three-terminal application:

$$I_1 = 10.0 \text{ A} \angle 160^\circ$$

$$I_2 = 8.0 \text{ A} \angle -175^\circ$$

$$I_3 = 12.0 \text{ A} \angle 30^\circ$$

The differential current is $I_{\text{DIF}(N)} = 11.2 \text{ A} \angle 128^\circ$.

Following the proposed method, we calculate:

$$R_1 = 97.37 \text{ A}^2, R_2 = 49.50 \text{ A}^2, R_3 = 20.14 \text{ A}^2$$

Therefore, the first current is selected as the reference, $I_p = 10.0 \text{ A} \angle 160^\circ$. This means one of the equivalent currents will be located on the line of 160° or -20° .

The restraining current is $I_{\text{RST}(N)} = 30.0 \text{ A}$.

Solving for the two-current equivalent, we obtain:

$$I_{L\text{EQ}} = 11.1 \text{ A} \angle 11.7^\circ \text{ and } I_{R\text{EQ}} = 18.9 \text{ A} \angle 160^\circ$$

Note that when calculated for this two-terminal equivalent, the differential and restraining currents are $11.2 \text{ A} \angle 128^\circ$ and 30 A , exactly as in the original three-terminal system.

The above two equivalent currents give the operating point on the Alpha Plane of $1.71 \angle 148.3^\circ$. Fig. 11 presents this case graphically.

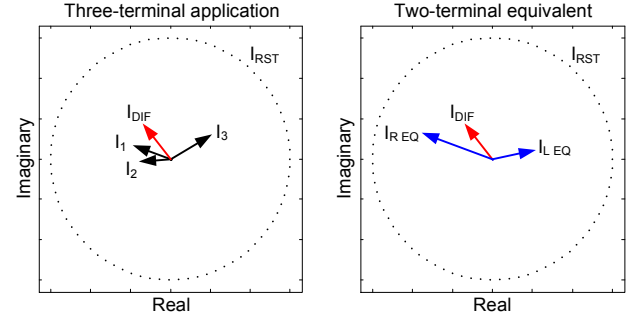

Fig. 11. Graphical illustration of the numerical Example 1.

2) Example 2

Continue the simulation example of Fig. 7, and refer to Fig. 12, presenting the zone differential and restraining currents in the A-phase. The equivalent Alpha Plane yields an operating point of about $0.5 \angle 170^\circ$. Note that in this case, the I_p current is selected with some approximation, as the line current differential system does not work directly with the individual currents at the faulted terminal. Still, the large restraint term compared with the spurious differential keeps the equivalent Alpha Plane in the blocking region.

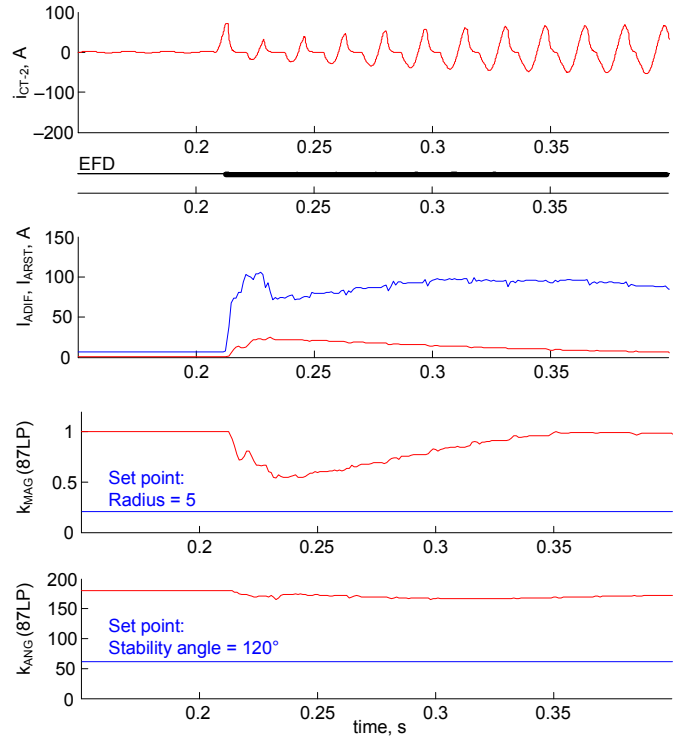

Fig. 12. Secondary current of the saturated A-phase CT for the case of Fig. 7, line differential and restraint currents, and the equivalent Alpha Plane—magnitude and angle.

D. Discussion

The generalized Alpha Plane allows implementation of the tried-and-true two-terminal principle to multiterminal lines, retaining key advantages while enabling new applications. The following are worth noticing:

- The generalized principle is transparent in two-terminal applications—the two equivalent currents always equal the two actual currents.
- In three-terminal applications, the principle behaves nearly identically, with the heuristic implementation of the two-terminal rule developed by analyzing possible current flow patterns.
- Any case with a balanced differential current yields an ideal blocking point on the Alpha Plane ($1 \angle 180^\circ$). Decreasing the differential current—such as by line-charging current compensation (Section VIII)—brings the Alpha Plane point closer to the ideal blocking position.
- Any case with higher restraint brings the Alpha Plane point closer to the ideal blocking point. The method allows applications where the restraint term is intentionally increased, such as when using harmonic restraint in transformer protection (Section IX).
- The principle works well without the need to communicate all local currents from all terminals. The line differential and restraint terms enabled by the proposed communications package map well into the generalized Alpha Plane.
- The principle works exceptionally well during external faults under CT saturation. First, by relying on the true restraint term, the calculated Alpha Plane point shows a strong blocking tendency. Second, extra security is added by the nature of the Alpha Plane itself.
- The principle works very well for the 87LQ and 87LG elements. Under internal faults, the elements' currents are close in phase and differ only by the system nonhomogeneity angles. The generalized Alpha Plane returns a strong unblocking indication in this case, regardless of the magnitudes of the compared currents. Under external faults, including faults that do not produce any natural restraint (phase-to-phase faults for the 87LG, for example), a cross-phase restraint may be used upon detecting an external fault (EFD bit asserted). With increased restraint, the equivalent Alpha Plane point shifts safely toward blocking.
- By reducing a differential zone of protection with any number of terminals to a single operating point on the Alpha Plane, the principle simplifies implementation, testing, and post-event analysis.

VIII. LINE-CHARGING CURRENT COMPENSATION

A. Impact of the Line-Charging Current and Benefits of Compensation

High-voltage overhead lines draw about 1 A per each kilometer of length (about 1.6 A per mile). For high-voltage cables and extra-high-voltage overhead lines, the total

charging current can amount to hundreds of primary amperes. In some cases, the charging current can be comparable with the fault current.

Line-charging current leaks from the differential measurement and affects both the security and dependability of differential protection. The phase differential element (87LP) is impacted more than the sequence elements (87LQ and 87LG).

Consider line energization, external faults, and internal faults in the context of the line-charging current.

1) Line Energization

During line energization, the energizing terminal draws the total charging current. If the energizing voltage is balanced and the line well transposed, the charging current is composed predominantly of positive-sequence current and therefore only affects the phase elements. If the line and/or the supply voltage are unbalanced, an unbalanced charging current may flow. As the charging current is fed from one terminal only, it appears as a single-feed current, and as such, it cannot be addressed by any restraint means. Increasing the pickup permanently above the charging current or using the remote breaker status to temporarily boost security are practical ways of dealing with the line-charging current during energization.

If the line is not well transposed and the total charging current is high, we may have to increase the pickup of the 87LQ and 87LG functions considerably, potentially diminishing their natural protection sensitivity.

2) External Faults

During external faults, changes in voltages induce extra charging current. This includes both fault inception and clearance. As the fault voltages are unbalanced, asymmetrical charging currents are induced, potentially impacting the 87LQ and 87LG functions.

This situation is not a major concern, however, because the external fault current produces restraints for all three 87LP, 87LQ, and 87LG functions. These restraint terms allow counterbalancing of the charging current component in the differential current. Weak systems may pose some challenge as they do not generate large currents that would boost restraint terms but allow voltages to depress considerably, thus creating larger charging currents.

3) Internal Faults

During internal faults, the charging current caused by the change in voltages subtracts from the fault current, potentially reducing sensitivity. Typically, this is not a major concern for the 87LQ and 87LG functions because high sensitivity is required during high-resistance ground faults, and these faults do not change voltages much. Therefore, only small zero- and negative-sequence charging currents are generated during high-resistance faults. However, if the pickup settings are increased to deal with energization of a poorly transposed line, sensitivity may be impacted.

In general, line-charging current is not a major concern for the 87LQ and 87LG functions, unless the line is not well transposed or is operated under considerable unbalance (e.g., caused by single-phase reactor operation).

If high sensitivity is required from the 87LP function, line-charging current is, however, a significant concern.

Line-charging current can be compensated for in a line current differential relay using voltage signals. This section explains and illustrates the basic principles of compensation and presents a method to make the compensation immune to problems with voltage transformers (VTs).

B. Principle of Line-Charging Current Compensation

The purpose of line-charging compensation is to remove the charging current from the differential current. Ideally, the method applied should work under balanced and unbalanced conditions, transposed and nontransposed lines, energization, external faults, internal faults, and other events.

With reference to Fig. 13, a multiterminal line draws a charging current through its distributed capacitances. The exact distribution of this current depends on the line and system parameters, as well as on the voltage profile along the line and its segments. Higher voltages draw larger charging currents. Open-ended lines develop an overvoltage at the open end while not drawing any current from that end. During faults (internal or external) voltages change and become unbalanced, causing changes in the charging current, with the charge flowing out and into the line.

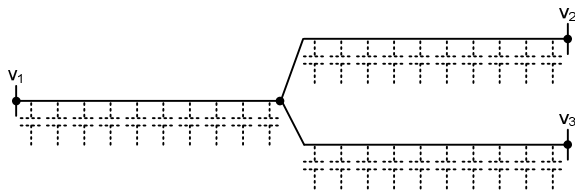

Fig. 13. Distributed capacitance three-terminal line.

From the differential protection point of view, however, the total charging current is of primary interest. Contributions to the differential current from the individual line terminals are secondary. If so, the total line-charging current can be well approximated as a current drawn by the total line capacitance under the average line voltage. The former is known and becomes a user setting. The latter can be calculated from the measured line terminal voltages.

With reference to Fig. 14, the line capacitance can be represented by a lumped parameter model at each terminal of the line that allows the line current differential relay to measure the voltage.

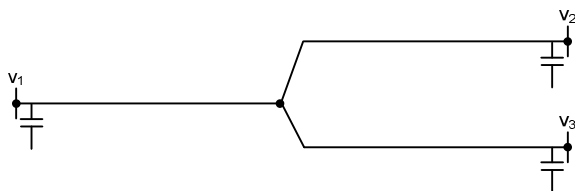

Fig. 14. Lumped parameter three-terminal line.

$$\dot{i}_{C_TOTAL} = C_{TOTAL} \cdot \frac{d}{dt} v_{AVERAGE} \quad (15a)$$

The average line voltage can be approximated by the average terminal voltage, and therefore:

$$\dot{i}_{C_TOTAL} = C_{TOTAL} \cdot \frac{1}{3} \cdot \frac{d}{dt} (v_1 + v_2 + v_3) \quad (15b)$$

Rearranging further:

$$\begin{aligned} \dot{i}_{C_TOTAL} &= \frac{1}{3} \cdot C_{TOTAL} \cdot \frac{d}{dt} v_1 + \frac{1}{3} \cdot C_{TOTAL} \cdot \frac{d}{dt} v_2 + \dots \\ &\dots + \frac{1}{3} \cdot C_{TOTAL} \cdot \frac{d}{dt} v_3 \end{aligned} \quad (15c)$$

In other words, the total charging current is the sum of three components:

$$\dot{i}_{C_TOTAL} = \dot{i}_{C1} + \dot{i}_{C2} + \dot{i}_{C3} \quad (16a)$$

each derived from a single line terminal voltage:

$$\dot{i}_{C1} = \frac{1}{3} \cdot C_{TOTAL} \cdot \frac{d}{dt} v_1 \quad (16b)$$

$$\dot{i}_{C2} = \frac{1}{3} \cdot C_{TOTAL} \cdot \frac{d}{dt} v_2 \quad (16c)$$

$$\dot{i}_{C3} = \frac{1}{3} \cdot C_{TOTAL} \cdot \frac{d}{dt} v_3 \quad (16d)$$

The above explains that each terminal can calculate a share of the total charging current based on local voltage and a portion of the total line capacitance proportional to the number of line terminals that perform the compensation at any given time.

These fractions of the charging current when summed up by the final differential current will null out the actual charging current.

This principle is key—the line current differential system effectively calculates the charging current based on the average voltage from all line terminals, without sending any voltages between the relays. Instead, each terminal subtracts its share of the charging current from the measured current and sends it to its peers (TX is transmitted to the peers; RX is received from the peers):

$$\dot{i}_{TX} = \dot{i}_{MEASURED} - \dot{i}_C \quad (17a)$$

and calculates the line differential current as:

$$\dot{i}_{DIF} = \dot{i}_{TX} + \sum \dot{i}_{RX} \quad (17b)$$

Using Fig. 14 as an example, the differential current is calculated as follows:

$$\begin{aligned} \dot{i}_{DIF} &= (\dot{i}_{MEASURED1} - \dot{i}_{C1}) + (\dot{i}_{MEASURED2} - \dot{i}_{C2}) + \\ &(\dot{i}_{MEASURED3} - \dot{i}_{C3}) \end{aligned} \quad (18a)$$

or

$$\begin{aligned} \dot{i}_{DIF} &= \dot{i}_{MEASURED1} + \dot{i}_{MEASURED2} + \dot{i}_{MEASURED3} - \\ &(\dot{i}_{C1} + \dot{i}_{C2} + \dot{i}_{C3}) \end{aligned} \quad (18b)$$

or

$$\dot{i}_{DIF} = \dot{i}_{MEASURED1} + \dot{i}_{MEASURED2} + \dot{i}_{MEASURED3} - \dot{i}_{C_TOTAL} \quad (18c)$$

The share of the charging current estimated at a given terminal may not equal the actual charging current supplied by

this terminal. The open line end is the ultimate case—the actual current supplied by the open terminal is zero, while this terminal estimates its share of the total charging current based on the voltage at the open end, provided line-side VTs are installed. At the same time, the closed terminal underestimates its share. When added up in the differential calculations, all the estimates of the charging current will, however, match the actual total charging current of the line.

In general, for a line with N terminals performing charging current compensation, each terminal uses $1/N$ of the total line capacitance and its own voltage to estimate its share of the charging current.

C. Three-Phase Implementation

As indicated by (15), the charging current is calculated as a derivative of the voltage signal, assuming known capacitance of the line.

A microprocessor-based relay uses digital filtering to calculate the time derivative.

In general, the following equation is used to calculate the phase-charging currents:

$$\begin{bmatrix} i_A \\ i_B \\ i_C \end{bmatrix} = \begin{bmatrix} C_{AA} & C_{AB} & C_{AC} \\ C_{BA} & C_{BB} & C_{BC} \\ C_{CA} & C_{CB} & C_{CC} \end{bmatrix} \cdot \frac{d}{dt} \begin{bmatrix} v_A \\ v_B \\ v_C \end{bmatrix} \quad (19)$$

For fully transposed lines, the matrix is symmetrical and is composed of the self- and mutual capacitances calculated from the zero- and positive-sequence susceptances of the line.

For nontransposed lines, the matrix is not symmetrical, and extra settings (in addition to the zero- and positive-sequence susceptances) are required to determine the matrix and perform accurate compensation.

Data required for the compensation are typically available from the commissioning records of the protected line.

Symmetrical components of the charging current are compensated for automatically by compensating the phase currents using (19).

Equation (19) is the time domain implementation of the method. Not only the fundamental frequency component but also the instantaneous values of the differential current are compensated. This allows for various algorithms that respond to signal features other than the fundamental frequency component to work well.

Note that the implementation method (19) works well under a variety of system conditions: energization, faults, open-pole conditions, and so on.

D. A Simulation Example

Fig. 15 through Fig. 17 illustrate a case of energizing a three-terminal 275 kV line, with a total length of 300 kilometers and the steady-state positive-sequence charging current of 230 A. The line is energized from the third terminal.

Fig. 15 shows the voltage and the calculated share of the charging current for the first terminal. Note that the actual charging current drawn from this terminal is zero (open breaker).

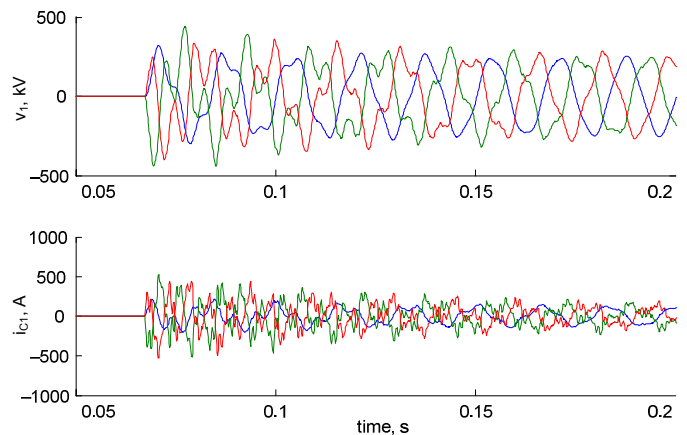

Fig. 15. Sample line energization: Terminal 1 voltage and the calculated share of the charging current.

Fig. 16 shows the voltage and the calculated share of the charging current for the second terminal. Again, the actual current supplied by this terminal is zero.

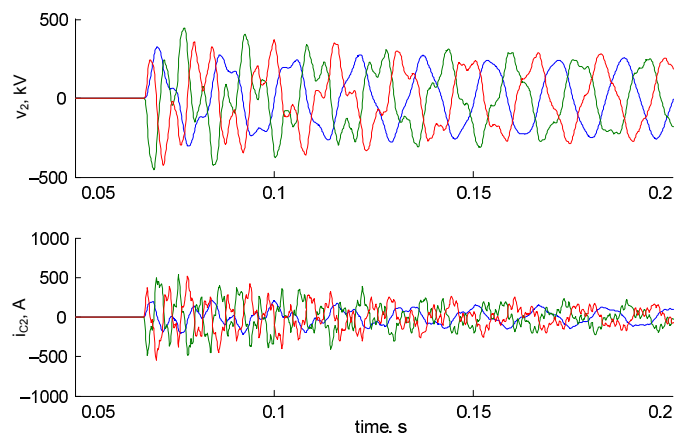

Fig. 16. Sample line energization: Terminal 2 voltage and the calculated share of the charging current.

Fig. 17 shows the voltage and the calculated share of the charging current for the third terminal. Note that this terminal supplies the actual charging current, and its calculated share is only about one-third of the actual current.

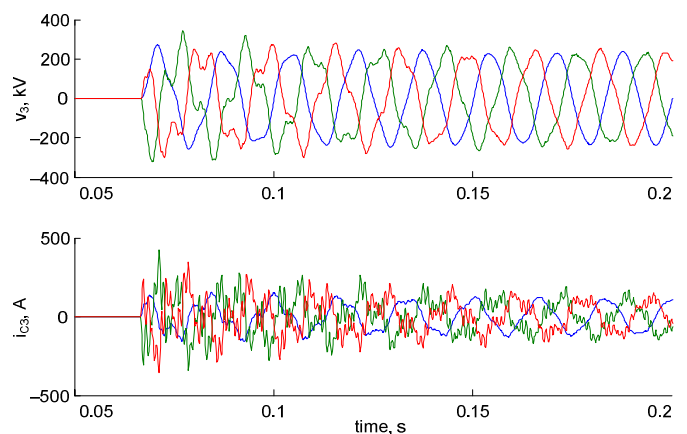

Fig. 17. Sample line energization: Terminal 3 voltage and the calculated share of the charging current.

Fig. 18 compares the actual and calculated charging currents. The actual charging current is the current measured at the energizing terminal (Terminal 3, in this example). The calculated current is the total of the charging current shares calculated at each of the line terminals.

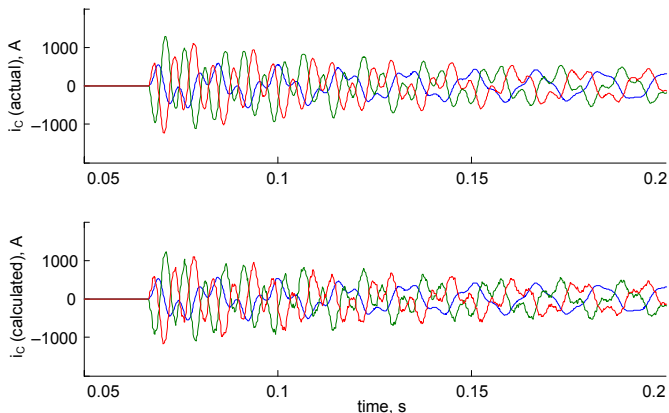

Fig. 18. Sample line energization: actual and calculated charging currents.

To illustrate the effect and accuracy of the compensation, Fig. 19 compares the differential currents without and with compensation. The differential current without compensation is the current measured at the energizing terminal. The differential current with compensation is the current calculated following (17). Note that a vast portion of the charging current is removed from the differential signal, and the remainder is of higher frequencies and will be further suppressed by the relay filtering algorithms.

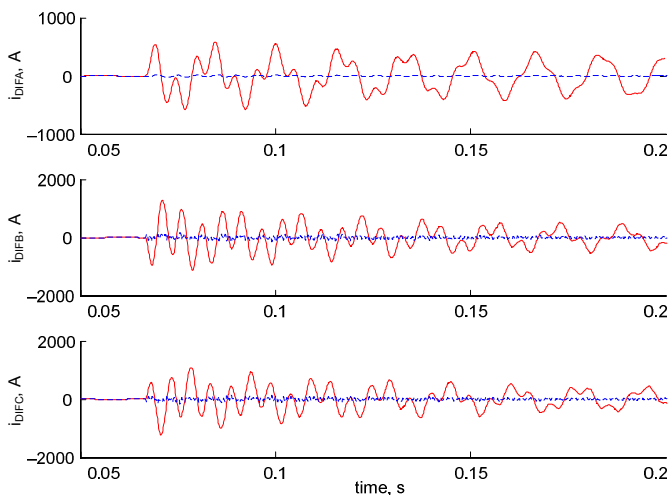

Fig. 19. Sample line energization: differential current without (solid line) and with (dashed line) charging current compensation.

E. Charging Current Compensation and Alpha Plane

The operating point on the Alpha Plane is derived from the differential and restraining auxiliary terms, as explained in Section VII.

By reducing the differential signal, the charging current compensation shifts the Alpha Plane operating point toward the blocking position. In an ultimate case of removing all the charging current, it yields the operating point of $1\angle 180^\circ$ on the Alpha Plane. This is not only the desired effect, but it happens without the knowledge of how the actual charging current divides between the terminals of the line.

During internal faults, the charging current compensation increases the differential signal by not allowing its inductive component to be reduced by the capacitive charging current. This compensation shifts the operating point on the Alpha Plane away from the blocking region as expected.

As a result, the differential elements (phase elements, in particular) can be set more sensitively when the charging current compensation is enabled.

An interesting design question arises regarding adding the calculated charging current to the restraint terms. On the surface, this is yet another current that feeds into differential calculations and as such should be included in the restraining terms that normally mirror the differential calculations. In this case, however, the proper design choice is not to include the calculated charging current in the restraint terms for the following reasons.

The actual charging current is measured by the relays and already contributes to the restraint terms. The calculated charging current is the countermeasure and should not be included, or else the charging current would be counted twice in the restraining terms.

In order to illustrate this issue, consider the case of line energization shown in Fig. 15 to Fig. 17. The actual charging current is measured at the third terminal and, in steady state, produces about 230 A of phase restraint current. At the same time, the compensated charging current is near zero. These values yield an operating point of $1\angle 180^\circ$ on the Alpha Plane, or a solid blocking indication.

This shows that the charging current compensation allows the trip equations to restrain properly rather than to block via an elevated pickup setting.

F. Accuracy of Compensation

The applied compensation method uses a lumped parameter model to estimate and subtract the line-charging current. This lumped model represents actual transmission lines well for frequencies up to a few hundred hertz.

Fig. 20 presents a frequency response of an admittance of a sample overhead line for several different line lengths, superimposed on the lumped parameter model. As we can see, the actual line and the lumped parameter model can differ considerably at higher frequencies, particularly for long lines (and it is long lines that benefit most from the compensation).

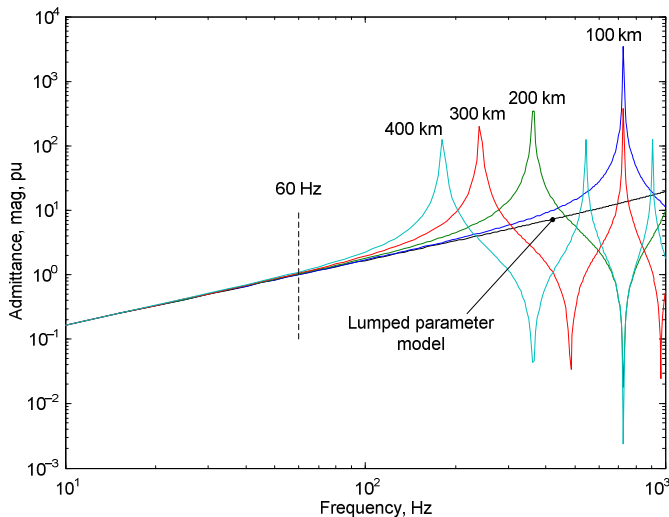

Fig. 20. Frequency response (admittance) of the actual line and the lumped parameter model.

In theory, we may develop a more accurate model of the line (compared with the $C \cdot dv/dt$) and implement it in a line current differential relay. The following are the disadvantages of this approach:

- The behavior of long transmission lines at higher frequencies is difficult to model without considerable amounts of data. There are differences between overhead transmission lines and cables. Mixed lines with some cable and overhead sections are difficult to cover. Line geometry, skin effects, and zero-sequence resistance have impact on the model. This approach would put extra burden on the user.
- The frequency response of the VTs would have to be factored in, making the problem even more complex.

The under-/overcompensated higher frequency components are not used for protection purposes and therefore do not have to be measured correctly. Instead, they are noise impacting other measurements and must be dealt with as such using known protection approaches, if they cannot be eliminated easily in a practical way.

One way to deal with the under-/overcompensated high-frequency charging current components is to produce an extra restraint from the high-frequency spectrum in the differential signal. With reference to Fig. 21, a high-pass filter is applied to extract high-frequency components from the instantaneous differential signal, and a root-mean-square (rms) measurement is used to boost the fundamental frequency restraint. In this way, if the high-frequency component affects measurements of the differential signal, it also automatically increases the corresponding restraint term. As a result, the equivalent Alpha Plane is kept secure.

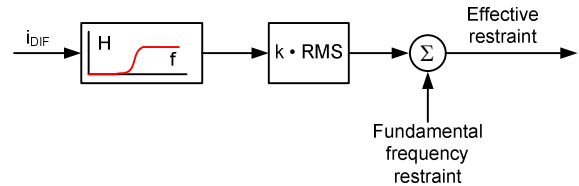

Fig. 21. Extra restraint term from the high-frequency spectrum in the differential current.

The desired approach is simply to remove the charging current for frequencies near the fundamental frequency because these frequencies affect the transient and steady-state response of the relay, while providing an extra restraint derived from higher frequencies in the differential signal.

G. Treatment of Line Reactors

Long lines that benefit from the charging current compensation feature of the relay often have shunt reactors installed inside the protection zone bounded by the location of the CTs connecting the line current differential scheme. The capacitive current of the line and the inductive current of the reactors do not cancel transiently as far as fast protection is concerned. The transient nature (frequency response) is different between an inductor and a capacitor, their positive-to-zero-sequence reactance ratios can be different, and reactor saturation makes the inductance nonlinear. In addition, reactors are switched on and off as a part of voltage/reactive power control in the power system and can be operated in an unbalanced way (one or two phases).

In order to keep protection applications simple, the reactor current is typically taken out of the measuring zone by paralleling its CTs with the line CTs. At any given time, the line may or may not be compensated, but the relay always measures the entire charging current and compensates for it.

With reference to Fig. 22, when applying the line-charging current compensation, the line differential zone excludes both the reactors and the charging current itself.

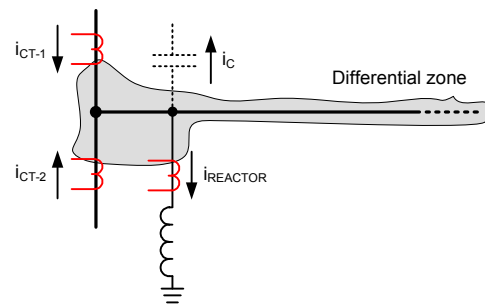

Fig. 22. Line reactors and line capacitance are removed from the differential protection zone.

H. Immunity to VT Problems

Charging current compensation makes the line current differential function partially dependent on availability of the voltage sources and exposes it to problems with the voltage signals. This is not a best solution, and the dependence on voltage should be remedied as much as possible.

The proposed scheme uses an extra bit in the communications payload to signal if the terminal actually

performs the compensation (charging current compensation in progress, CCC).

A relay at a given terminal may not calculate and subtract its share of the charging current for the following reasons: VTs are not installed or not wired to the relay; a problem is detected with the VTs (loss of potential), and the charging current compensation logic suspends compensation based on this voltage; or bus-side VTs are used while the line breaker is opened, and the logic suspends usage of this voltage as not representative for the line.

Each set of received currents is either compensated or not as per the accompanying CCC flag. Each receiving terminal therefore knows how many terminals actually subtract their share of the charging current and can calculate its own share of compensation in order to make up for the full charging current of the line.

In this way, the system works with a variable number of compensating terminals and is partially immune to the loss of one or more sets of VTs.

Consider the following examples.

1) Example 1

Assume a three-terminal application and one terminal with no voltage source. The relay with no voltage does not compensate its currents and permanently sends $CCC = 0$ to the other peers. Each of the receiving peers sees that the said terminal does not compensate, and there are a total of two terminals that do compensate. As a result, each of them will apply a multiplier of $1/2$ in their equations for the share of the charging current. In this way, the charging current is compensated fully, using an average of the two terminal voltages that are available to the line current differential system. Note that the terminal with no voltage still works with a fully compensated differential current.

2) Example 2

Assume a three-terminal application and one terminal with a bus-side voltage. Normally, each terminal performs the compensation by applying the multiplier of $1/3$ and asserting the CCC bit. At the moment the terminal that uses a bus-side voltage detects any pole open, it deasserts its CCC flag and ceases to compensate its current. The other two terminals recognize that from the received CCC flag, switch their multipliers from $1/3$ to $1/2$, and the compensation continues, using the two voltages that are representative of the line voltage profile.

3) Example 3

Continue the second example, and assume that subsequently one of the other terminals detects loss of potential. It deasserts the CCC flag and stops compensating its outgoing current. The only terminal with a healthy voltage now knows that the second peer lost the compensation and switches its multiplier from $1/2$ to 1 . In this way, the compensation is done with the single voltage that is still available. As such, it will be less accurate but still useful. The other two terminals still receive $CCC = 1$ from the last terminal capable of compensation and know that the line differential current is fully compensated.

This scheme makes the charging current compensation feature more immune to problems with VTs. In a way, individual relays in the line current differential system work as remote backup voltage sources for each other. If all voltages are lost, the relay automatically desensitizes to ensure security and continues working with currents only.

IX. IN-LINE TRANSFORMERS

A. Introduction

In some applications, a line and a transformer are installed without a breaker in between to separate the two pieces of equipment (see Fig. 23). This is often driven by economics, particularly in cases when the line is not tapped or multiterminal, and the transformer does not feed any other loads. Thus, installing a separating breaker does not add any operational flexibility. The lack of a separating breaker puts both the line and the transformer into the same trip zone, regardless of which element actually requires isolation from the rest of the system.

It is still beneficial to apply two measuring zones in this case, as shown in Fig. 23a, even if they both trip both the line and the transformer. By using relays designed for a given type of apparatus, we maximize the overall performance of the protection system, sensitivity to transformer faults in particular.

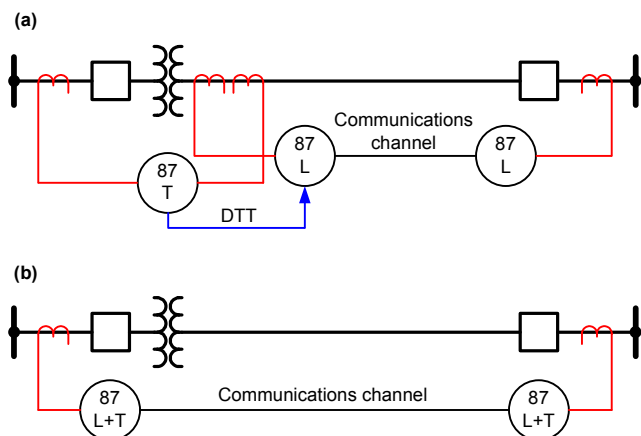

Fig. 23. Transformer and line protection—individual (a) and combined (b) measuring zones.

There is a trend, however, to combine the two measuring zones in a line current differential relay with an in-line transformer feature, as shown in Fig. 23b. This approach simplifies the application because fewer relays, less wiring, and less labor are required.

This section elaborates on the relay design to support in-line transformers.

B. Transformer Protection Using the Alpha Plane Differential Element

Being a differential principle, the Alpha Plane technique can provide short-circuit protection for power transformers.

First, the local currents are compensated for transformer connections to follow the art of transformer differential protection. Commonly referred to as ratio (tap) matching,

zero-sequence removal, and vector group compensation, the differential current equations actually match ampere-turns for a healthy transformer. For example, for a delta/wye transformer, the following equations describe the differential signal:

$$i_{DIF(1)} = k_{\Delta} \cdot i_{\Delta A} + k_Y \cdot \frac{1}{\sqrt{3}} \cdot (i_{YA} - i_{YB}) \quad (20a)$$

$$i_{DIF(2)} = k_{\Delta} \cdot i_{\Delta B} + k_Y \cdot \frac{1}{\sqrt{3}} \cdot (i_{YB} - i_{YC}) \quad (20b)$$

$$i_{DIF(3)} = k_{\Delta} \cdot i_{\Delta C} + k_Y \cdot \frac{1}{\sqrt{3}} \cdot (i_{YC} - i_{YA}) \quad (20c)$$

The taps, k_{Δ} and k_Y , are based on the CT and transformer ratios, and indices 1, 2, and 3 refer to the loops of the differential function.

The restraining terms are created as mirror equations to the differential terms (20):

$$i_{RST(1)} = k_{\Delta} \cdot |i_{\Delta A}| + k_Y \cdot \frac{1}{\sqrt{3}} \cdot |i_{YA} - i_{YB}| \quad (21a)$$

$$i_{RST(2)} = k_{\Delta} \cdot |i_{\Delta B}| + k_Y \cdot \frac{1}{\sqrt{3}} \cdot |i_{YB} - i_{YC}| \quad (21b)$$

$$i_{RST(3)} = k_{\Delta} \cdot |i_{\Delta C}| + k_Y \cdot \frac{1}{\sqrt{3}} \cdot |i_{YC} - i_{YA}| \quad (21c)$$

For a general case on an N-winding transformer, the differential and restraining signals are sums of ratio-matched and vector-compensated winding currents. The above observation leads to a simple relay implementation of compensating the individual currents for transformer connections based on the position of the current with respect to the various transformer windings and running the regular line current differential communications and processing algorithms based on the transformer-compensated currents (Fig. 24).

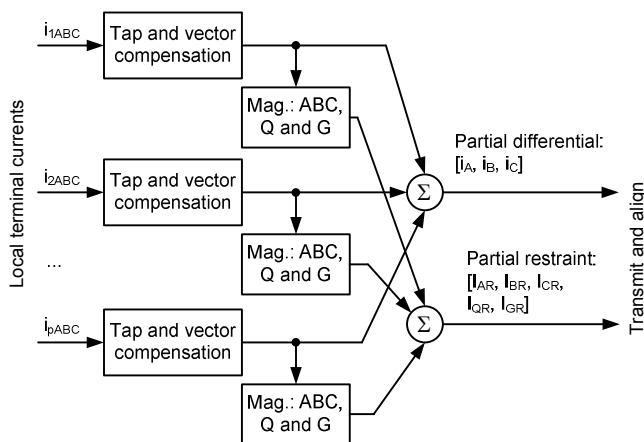

Fig. 24. Compensating currents for transformer connections in a line current differential scheme.

For example, the line terminal associated with the delta winding in this example performs the following operations to obtain its instantaneous currents for transmission:

$$i_A = k_{\Delta} \cdot i_{\Delta A} \quad (22a)$$

$$i_B = k_{\Delta} \cdot i_{\Delta B} \quad (22b)$$

$$i_C = k_{\Delta} \cdot i_{\Delta C} \quad (22c)$$

while the terminal associated with the wye winding obtains its terminal currents using the following equations:

$$i_A = k_Y \cdot \frac{1}{\sqrt{3}} \cdot (i_{YA} - i_{YB}) \quad (23a)$$

$$i_B = k_Y \cdot \frac{1}{\sqrt{3}} \cdot (i_{YB} - i_{YC}) \quad (23b)$$

$$i_C = k_Y \cdot \frac{1}{\sqrt{3}} \cdot (i_{YC} - i_{YA}) \quad (23c)$$

After operations (22) and (23), the resulting currents can be processed as if there were no in-line transformer. In particular:

- The charging current is subtracted after being compensated for transformer connections.
- The phase and sequence restraint terms are calculated.
- The partial differential and restraint terms are created based on the number of local currents.
- The partial differential and restraint terms are sent, received, and aligned.
- The total line differential and restraint terms are calculated.

At this point, the nature of transformer differential protection needs to be recognized by addressing the inrush and overexcitation phenomena.

Inrush and overexcitation harmonic blocking are naturally performed by measuring the second and fifth harmonics in the differential current and comparing them with user thresholds. Cross-phase blocking or the fourth harmonic can be used, depending on the design and user preferences [4] [6].

Harmonic restraint is also easy to implement using the generalized Alpha Plane principle of Section VII. The harmonics of interest in the differential current (second, fourth, and fifth) are added to the fundamental frequency restraint terms using appropriate multipliers as per the principles of harmonic restraint.

Subsequently, the generalized Alpha Plane calculations are executed. If the restraint terms are increased sufficiently by the harmonics in the differential signal, the boosted restraint shifts the Alpha Plane toward the blocking point and restrains the differential function during inrush conditions.

In order to provide adequate transformer protection, the blocking region of the Alpha Plane needs to be set smaller in applications with in-line transformers as compared with applications for transmission lines.

C. 87LQ and Sensitivity to Transformer Faults

The negative-sequence transformer differential function (87TQ) has proven to be very sensitive and capable of detecting turn-to-turn faults [4].

The 87LQ function works naturally with in-line transformers within the implementation described above. It can be set sensitively because of the external fault detection logic.

The 87LQ function provides good sensitivity to turn-to-turn transformer faults and high-resistance line faults. As a result, the combined transformer and line protection application using the presented approach can be considered adequate.

D. Application Considerations

A separate transformer relay may still be a better option to provide other transformer functions, such as overexcitation, thermal, or restricted earth fault protection. For smaller- and medium-sized transformers, these functions may not be required or may be provided in a nonredundant fashion using the second protection system.

If the line generates considerable charging current (cables, for example), the line capacitance may affect harmonics in the differential current and cause some problems related to harmonic blocking or restraining. The charging current compensation feature remedies the problem, but nonetheless, care should be taken when considering in-line transformer applications with considerable line-charging current.

Using dual CT input relays capable of multiterminal applications may provide protection for combinations of lines, transformers, or small buses, as illustrated in Fig. 25. For cases where two relays are located in the same substation, it is not necessary to equip all relays with two communications channels—one of two relays in the same substation is equipped with a communications link toward the remote relay, and the other relay as well as the remote relay can operate in the slave mode in order to save one communications channel between the two stations.

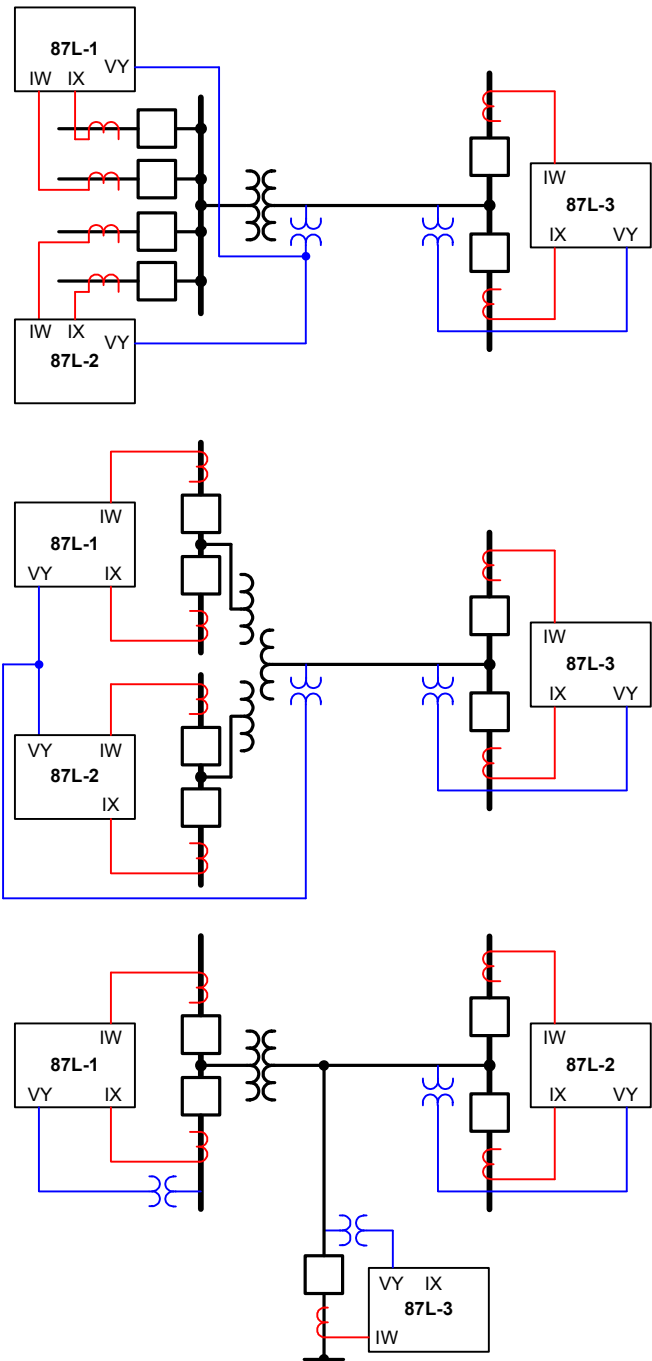

Fig. 25. Sample applications with in-line transformers.

X. SPEED OF OPERATION

The following delays limit the operating speed of a line current differential relay:

- Internal relay data latencies
- Algorithm delay
- Channel delay

Relay designers have no control over the last component. Direct fiber connections add negligible delay to the scheme. Multiplexed channels can add a delay in the range of a few milliseconds to tens of milliseconds, depending primarily on the number of devices passing the data between the relays and, to a degree, on the length of the fiber path linking the

multiplexers or modems. Selection of a communications channel in terms of the worst-case latency is one of the engineering steps needed to fulfill the required fault clearance time.

Internal relay data latency adds to the trip time as well. This includes collecting and passing samples from the A/D converter, processing the local data for transmission, assembling outgoing packets, accepting incoming packets, aligning the data, processing the global differential calculations, and asserting the outputs. Modern relay platforms optimize the above processes for speed. The presented solution sends and receives packets every 3 milliseconds, allowing for lower relay latencies and faster operation.

The algorithm time refers to the length of a data window that must be available before a trip decision can be made. It should not be mistaken for the length of the filter data windows—it is simply a point in time when enough information is available to make a reliable trip decision.

In this respect, the 87LQ and 87LG functions are very fast. Even when using full-cycle filters, these functions assert their outputs in a fraction of a cycle (see Fig. 26, for example). This short response time is because they are not biased by the load current prior to the fault. Owing to the proper restraining techniques, the external fault detection logic, and the charging current compensation, these functions can be operated at their natural speed without introducing much intentional delay for security purposes.

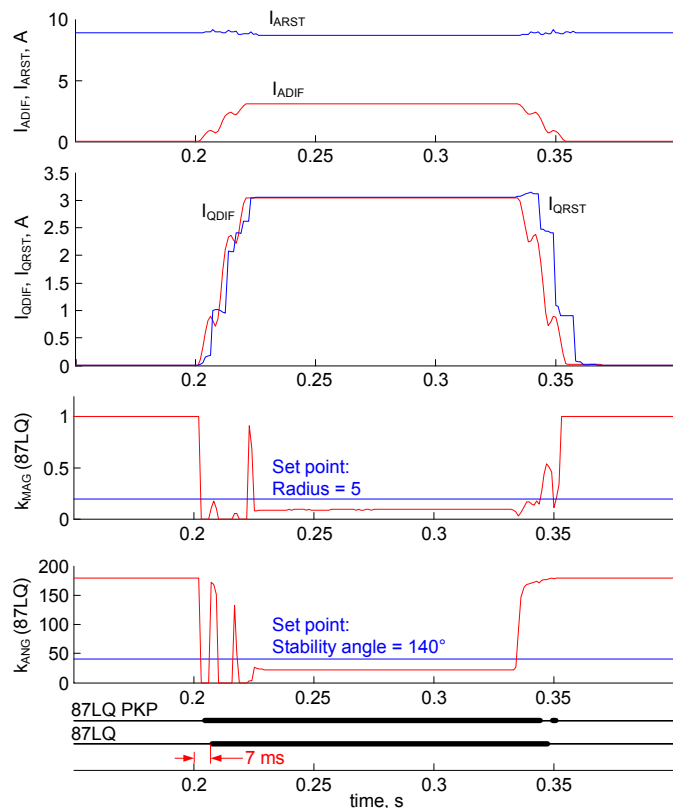

Fig. 26. Operation of the 87LQ function for a 100 Ω AG fault.

In addition, the 87LP element uses a high-speed element in parallel with the full-cycle filtered path. The high-speed

differential protection is feasible in the proposed scheme because the key signals are available as samples. In a differential scheme, most of the transients cancel in the operating signal, and therefore it is secure to make trip decisions based on less than a full cycle of data. CT saturation may cause problems, but this issue is addressed by fast and reliable EFD logic. If the EFD asserts, the high-speed path is inhibited.

As a result of careful design, the relay architecture minimizes data latencies. The applied protection algorithms are fast under internal fault conditions because they are restrained in a way that does not penalize speed. Overall, the presented solution provides for subcycle trip times if used with fast communications channels.

XI. DATA HANDLING AND SYNCHRONIZATION

A. Introduction

Proper data handling and synchronization are the foundation on which a line current differential relay is built. This is as important as the protection algorithms and logic. A careful design is required because this part of the relay relates to the channel and associated third-party equipment that are often only under limited control of protection engineers.

The following requirements apply to the data handling and synchronization subsystem:

- Unified packet structure and near-identical processing for the channel-based synchronization and the external time reference synchronization methods.
- Minimum requirement for extra payload to communicate sequence numbers, time stamps, and other timing and data-tagging information.
- Security under and fast recovery from lost packets and channel brownout conditions.
- Immunity to step changes and variations in channel delay.
- Ability to work with channels having a total round trip delay of 80 milliseconds or less.
- Accuracy of data alignment better than about 1.0 electrical degree (this yields a spurious differential current of less than 1 percent of the through current).
- Quick startup, in the order of a few tens to few hundreds of milliseconds, without the need for clock synchronization or similar mechanisms.
- In applications with external time reference, ability to measure actual channel delays independently in the transmit and receive directions.

The presented solution is based on estimating the clock offset and compensating the data time stamps for this offset. The sent current data are time-stamped according to the time of the relay that took the data. This time is synchronized to an external source (typically GPS) if such an external source is available. Otherwise, the relay time is freewheeling, and the time difference between any two relays may drift.

The line current differential system measures the clock offset and augments the time stamps to express both the local and the remote data in the same consistent time.

Under the channel-based synchronization method, the time offset is truly measured. Because the estimated offset changes very slowly, heavy averaging of the raw measurements is applied, allowing the scheme to ride through a temporary channel loss, corrupted packets, channel switching, and other impairments.

Under the external time reference method, the clock offset is known and equals zero.

When configured to use the channel-based synchronization method, the system measures the clock offset and uses it even if the two relays are synchronized to an external time reference and the calculations return the clock offset of zero. The method does not depend on the availability or precision of the external time source, even if the latter is connected and available, unless an explicit user setting mandates using the external time reference synchronization method.

When compared to a method that forces synchronization of the relay sampling clocks, the approach presented in this paper is both simpler and more robust. By estimating a slowly changing parameter (the clock offset), the scheme applies averaging and benefits from the resulting advantages. By not having to synchronize sampling clocks, the scheme can be naturally extended on multiterminal applications and allow a mixed synchronization mode in which some data are synchronized based on symmetrical channels and some are synchronized externally. The latter approach limits exposure of the scheme to problems with the external time reference.

This section explains the two synchronization methods in more detail and discusses fallback strategies for the loss of the external time reference.

B. Channel-Based Synchronization

Refer to Fig. 27. In the presented design, Relay 1 collects three fresh current samples for transmission, forms the packet, and at time t_0 , precisely t_{TX} after the newest sample was taken, sends the packet out. The packet is marked with a sequence number to identify it at the time of usage. The time t_0 is captured by Relay 1 using its own local time. An explicit time stamping for the outgoing message can be used, or the t_0 time can be derived from the time stamp of the newest sample in the packet and the t_{TX} design constant.

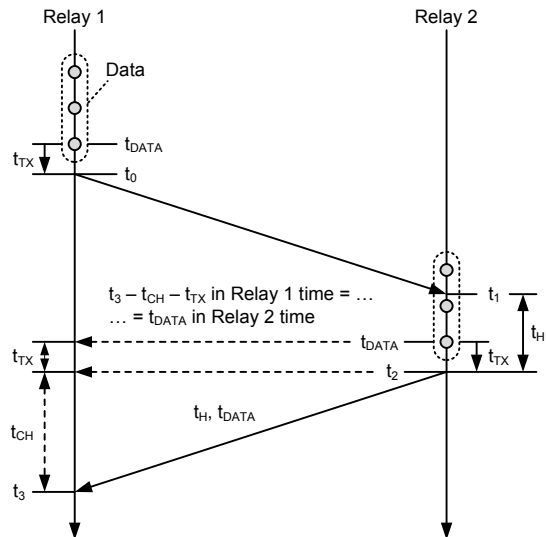

Fig. 27. Illustration of the channel-based synchronization method.

The packet arrives at Relay 2 after the unknown channel delay time (few milliseconds to tens of milliseconds). Relay 2 captures the packet arrival time t_1 using its own local clock. This clock is asynchronous from the clock of Relay 1. Time t_1 is required to measure the message hold time (turnaround time) at Relay 2 in order to facilitate the ping-pong algorithm for estimation of the channel delay.

Some time afterwards, Relay 2 has collected three fresh samples of its own currents and is ready to send them to Relay 1. Again, precisely t_{TX} after the newest sample has been taken, a message is launched by Relay 2 to Relay 1. The message goes out at time t_2 . The hold time $t_H = t_2 - t_1$ is included in the payload of the message. This time is known in advance because the message is started after a constant delay t_{TX} from the newest sample in the packet, and the current samples are located at known points in time. Therefore, the hold time can be precalculated at some point after capturing t_1 and be conveniently put in the packet ahead of the transmission time. Relay 2 returns the message sequence number, letting Relay 1 know that the hold time returned to Relay 1 was for the message that originated at t_0 .

In its packet, Relay 2 includes a time stamp for the current samples t_{DATA} (assume the time stamp of the newest sample in the set of three). In a practical implementation, the packet sequence number and this time stamp can be the same number.

Relay 1 receives the packet after the channel delay (few milliseconds to tens of milliseconds). It captures the time of reception as t_3 using its own clock. From the sequence number received, Relay 1 knows this is a reply to the message sent out at time t_0 .

At this point, Relay 1 can finish the key calculations related to channel delay, clock offset, and data alignment.

Assuming symmetrical channel delay, the one-way channel delay is:

$$t_{\text{CH}} = \frac{(t_3 - t_0) - t_{\text{H}}}{2} \quad (24)$$

Note that the difference between t_3 and t_0 is the time elapsed at the local relay, and the hold time is the time measured by the remote relay and communicated back explicitly. Therefore, (24) makes sense even though its components were derived from two asynchronously running clocks.

Backdating t_3 by the channel delay time, we get the transmission time at Relay 2 expressed in the local time of Relay 1:

$$t_{2(@\text{relay1})} = t_3 - t_{\text{CH}} \quad (25)$$

Backdating further by the known delay in transmitting a packet after capturing the data, we obtain the data time stamp expressed in time of Relay 1:

$$t_{\text{DATA}(@\text{relay1})} = t_3 - t_{\text{CH}} - t_{\text{TX}} \quad (26)$$

The data time stamp expressed in Relay 2 time is included in the packet. This allows calculating of the time offset (i.e., the difference in time between the two relays):

$$\begin{aligned} t_{\text{OFFSET}} &= t_{\text{DATA}(@\text{relay1})} - t_{\text{DATA}} = \dots \\ &\dots = t_3 - t_{\text{CH}} - t_{\text{TX}} - t_{\text{DATA}} \end{aligned} \quad (27)$$

Positive values of the offset time mean the local clock (Relay 1) is leading the remote clock; negative offset means the remote clock is ahead.

Inserting (24) into (27) gives the following key equation:

$$t_{\text{OFFSET}} = \frac{1}{2} \cdot (t_0 + t_3 + t_{\text{H}}) - t_{\text{TX}} - t_{\text{DATA}} \quad (28)$$

Note that the clock offset value is a very stable number because it reflects a difference between clocks of the two relays, regardless of data latency and therefore regardless of the channel delay at any given moment. This number may change at a rate of a few parts per million, depending on the stability of the oscillators used in the relay hardware. Therefore, it is both possible and recommended to average the relay clock offset given by (28) over a number of measurements. This allows riding through channel impairments and increases accuracy by letting the rounding-up errors and jitter average out.

The clock offset value is used to correct the remote time stamp into the local time:

$$t_{\text{DATA}(@\text{relay1})} = t_{\text{DATA}} + t_{\text{OFFSET}} \quad (29)$$

C. External Time Reference-Based Synchronization

Refer to Fig. 28. With both relays synchronized to the same external time source, their local times are mutually synchronized. The relays take samples at the same points in time (relative to the top of a second) and assign the same time stamps to the simultaneously taken data. The data are therefore used by the scheme directly based on the time stamps, applying the same equations as in the channel-based synchronization mode, except for the clock offset not calculated, but known:

$$t_{\text{OFFSET}} \equiv 0 \quad (30)$$

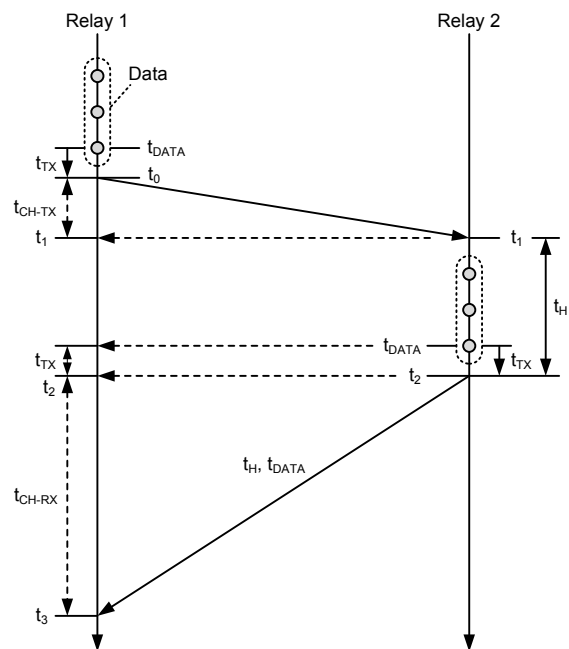

Fig. 28. Illustration of the external time reference-based synchronization method.

The rest of the scheme works the same way as in the channel-based synchronization mode. In particular, the message transmit and receive times are captured, and the hold time is communicated.

These values have a different usage, however. They allow the relay to characterize the communications channel as follows.

The channel delay in the receive direction at Relay 1 is calculated as:

$$t_{\text{CH-RX}} = t_3 - t_2 = t_3 - (t_{\text{DATA}} + t_{\text{TX}}) \quad (31)$$

The channel delay in the transmit direction at Relay 1 is calculated as:

$$t_{\text{CH-TX}} = t_3 - t_0 - t_{\text{H}} - t_{\text{CH-RX}} \quad (32)$$

The two channel times are made available to the user for alarming and overall channel monitoring.

Also, these channel measurements can be used to control the response of the differential system to the loss of the external time reference, as discussed later.

D. Sources of External Time Reference

Historically, the common time reference has been provided via an IRIG-B connection from a GPS-synchronized substation clock. This dependency on time reference used to create some concerns for protection applications in terms of relying on extra equipment and exposing the differential system to the failure modes thereof. The failure points included the connection between the relay and the clock, including copper-to-fiber conversion, if any, the clock itself, its cabling and antenna, and finally the broadcast of the GPS signal itself.

Availability of the GPS signal concerned some users, particularly outside of North America, while the GPS infrastructure that was originally designed for military use migrated into civilian applications. Presently, GPS applications are so widely spread that the long-term viability of GPS is not questioned anymore.

Still, good protection solutions utilize as little equipment and connections as possible in order to maximize availability and remove unnecessary failure modes.

In this respect, it is worth noticing that terrestrial wide-area systems emerged recently that provide for precise timing independently from the GPS time. One solution uses the internal precise timing of a SONET system to serve common time at individual multiplexer nodes. Normally, this common time is synchronized to GPS via an array of receivers placed at different geographical locations, but if all GPS receivers are lost or the GPS system itself becomes unavailable, the common wide-area time continues to be generated internally by the SONET system [1].

This enhances the availability of line current differential schemes operating in the external time reference synchronization mode.

Even with this improvement, we need to consider a failure mode of losing the time reference because of problems with connections for the timing signal (IRIG-B or IEEE 1588 via Ethernet).

E. Fallback Strategies for Loss of External Time Reference

In the external time reference mode, the line current differential system loses synchronization if the external time reference is lost for an asymmetrical channel.

Misoperation is not an option, and the complete loss of protection is not a preferred solution. Therefore, a fallback strategy should be considered in order to provide security and some protection functionality under such a contingency.

The following options could be considered:

- The 87L function can be left as is for a certain period of time after losing the common time reference. It will take some time for the internal relay clocks to drift apart, and the system will stay synchronized at least for few seconds. During that time, the clock offset remains zero even if one of the relays does not synchronize to the common time. If the external time

source does not recover after some time, the danger of the clocks drifting apart increases, and the scheme needs to take other steps, as explained below.

- In applications with only some channels being asymmetrical, the line current differential system can mark the asymmetrical channels that lost a time reference at either end as unavailable. With enough remaining connections between the relays, a master-slave operation may be possible, retaining the functionality of the system at the expense of slightly delayed tripping at the slave sites.
- The 87L function can disable itself automatically if any of the required time references are lost.
- The 87L function can desensitize itself to a degree if any of the required time references are lost.
- If the used channel was symmetrical just prior to losing the external time reference, the line current differential system may switch to the channel-based synchronization mode. This mode continues indefinitely, assuming the channel stays symmetrical until the time reference recovers. Or this mode can stay in place until the total (round trip) channel time changes, signifying the fact that the channel has been switched and may become asymmetrical as a result of the switching.
- Similarly, if the channel displayed a stable limited asymmetry prior to losing the time reference, this asymmetry can be used to predict the worst-case measurement errors and put in place appropriate protection countermeasures (stability angle setting for the Alpha Plane). The channel may switch into channel-based synchronization, applying enough protection countermeasures to fight the possible spurious differential current. This situation may continue indefinitely or until the total channel time changes, signifying channel switching and possible increase in asymmetry.
- Similarly to the above option, the worst-case channel asymmetry can be tracked and stored in the relay. This worst-case asymmetry can be used to calculate secure 87L settings, and the system can switch to channel-based synchronization upon losing the external time reference. The initial value of the worst-case asymmetry is a user estimate, but during the life of the installation, channels with common time references at both ends can be characterized by the relays for the worst-case asymmetry.

XII. CONCLUSIONS

This paper outlines general design directions for a next generation line current differential protection scheme.

Regarding synchronization and data alignment, the presented solution is unified for the channel-based and the external time reference-based synchronization methods. By not forcing the sampling clocks to sample synchronously, the presented solution works naturally and is more robust in multiterminal applications.

A terrestrial, GPS-independent time source was introduced, making line current differential applications with asymmetrical channels safer and more dependable.

A number of fallback strategies were presented to allow the system to ride through the temporary loss of the timing source.

A reliable Alpha Plane restraining technique was proposed for multiterminal applications with any number of local current inputs to the relays. The size and structure of the communications payload are independent from the number of terminals or the number of local currents in the system, making the implementation simple and thus the solution more robust.

The system works with high-fidelity current information, allowing a fast external fault detection logic as well as harmonic measurements for in-line transformer applications.

The combination of the high-performance external fault detection logic capable of detecting external faults based on as little as 3 milliseconds of unsaturated current waveforms and the proper restraining techniques makes the relay both very secure and fast. As in the case of modern bus or transformer relays, application of the external fault detection relaxes CT requirements considerably and simplifies application by eliminating a cumbersome analysis of suitability of the applied CTs and settings.

The presented solution applies the Alpha Plane differential trip equations, carrying forward all tried-and-true advantages of this approach, but enhances the original concept to multiterminal applications and allows for harmonic restraining of the Alpha Plane to facilitate in-line transformer protection.

Line-charging current compensation was incorporated, enhancing security during line energization and improving sensitivity to internal faults. A novel concept of dynamic selection of voltage sources for the compensation was introduced, minimizing dependence of the scheme on VTs.

Communications packets and data handling internal to the relays were designed for low latencies. Combined with high-speed performance of the applied protection equations, this enables subcycle trip times in applications with fast communications channels.

XIII. REFERENCES

- [1] K. Fodero, C. Huntley, and D. Whitehead, "Wide-Area Time Synchronization for Protection," proceedings of the 36th Annual Western Protective Relay Conference, Spokane, WA, October 2009.
- [2] J. Roberts, D. Tziouvaras, G. Benmouyal, and H. Altuve, "The Effect of Multiprinciple Line Protection on Dependability and Security," proceedings of the 55th Annual Georgia Tech Protective Relaying Conference, Atlanta, GA, May 2001.
- [3] A. Guzmán, C. Labuschagne, and B.-L. Qin, "Reliable Busbar and Breaker Failure Protection With Advanced Zone Selection," proceedings of the 31st Annual Western Protective Relay Conference, Spokane, WA, October 2004.
- [4] A. Guzmán, N. Fischer, and C. Labuschagne, "Improvements in Transformer Protection and Control," proceedings of the 62nd Annual Conference for Protective Relay Engineers, College Station, TX, March 2009.
- [5] G. Benmouyal, "The Trajectories of Line Current Differential Faults in the Alpha Plane," proceedings of the 32nd Annual Western Protective Relay Conference, Spokane, WA, October 2005.

- [6] K. Behrendt, N. Fischer, and C. Labuschagne, "Considerations for Using Harmonic Blocking and Harmonic Restraint Techniques on Transformer Differential Relays," proceedings of the 33rd Annual Western Protective Relay Conference, Spokane, WA, October 2006.

XIV. BIOGRAPHIES

Henry (Hank) Miller has a BSEE and a BEE from The Ohio State University and a BA degree in philosophy from The Pontifical College Josephinum. He is a registered professional engineer in the state of Ohio and holds a patent for a substation steel design. Hank has over 31 years of utility experience in station and line protection and control. Hank is currently working as a staff engineer and supervisor in the protection control asset engineering group of American Electric Power (AEP) with responsibilities for developing protection and control standards and application guides and supporting the relay setting project work. With John Burger, he shares the responsibility for ensuring that devices new to the AEP system are protected and controlled properly. Hank is a member of the IEEE.

John Burger has a BSEE from Case Institute of Technology and an MSEE from Fairleigh Dickinson University. He is a registered professional engineer in the states of Ohio and New Jersey. John has over 35 years experience in station and line relay protection and control. He has worked for American Electric Power (AEP), primarily in the protection and control group, for the last 29 years. John is currently serving as a staff engineer and supervisor in the protection control asset engineering group, with responsibilities for developing protection and control standards and application guides and supporting the relay setting project work.

He shares the responsibility for ensuring that devices new to the AEP system are protected and controlled properly with Hank Miller. John is a Senior Member of the IEEE, past chairman of the Columbus Chapter of the PES, a member of the IEEE Power System Relay Main Committee, Substation and Communications Subcommittees and chairman of Working Group H6. He is also currently serving as Chairman of the UCA International Users Group, providing technical support for IEC 61850.

Normann Fischer received a Higher Diploma in Technology, with honors, from Witwatersrand Technikon, Johannesburg in 1988, a BSEE, with honors, from the University of Cape Town in 1993, and an MSEE from the University of Idaho in 2005. He joined Eskom as a protection technician in 1984 and was a senior design engineer in Eskom's protection design department for three years. He then joined IST Energy as a senior design engineer in 1996. In 1999, he joined Schweitzer Engineering Laboratories, Inc. as a power engineer in the research and development division. Normann was a registered professional engineer in South Africa and a member of the South Africa Institute of Electrical Engineers. He is currently a member of IEEE and ASEE.

Bogdan Kasztenny is a principal systems engineer in the research and development division of Schweitzer Engineering Laboratories, Inc. He has 20 years of experience in protection and control, including his ten-year academic career at Wroclaw University of Technology, Poland, Southern Illinois University, and Texas A&M University. He also has ten years of industrial experience with General Electric, where he developed, promoted, and supported many protection and control products.

Bogdan is an IEEE Fellow, Senior Fulbright Fellow, Canadian member of CIGRE Study Committee B5, and an Adjunct Professor at the University of Western Ontario. He has authored about 200 technical papers and holds 16 patents. He is active in the Power System Relaying Committee of the IEEE and is a registered professional engineer in the province of Ontario.