

---

**THE IMPACT OF HIGH FAULT CURRENT AND CT RATING  
LIMITS ON OVERCURRENT PROTECTION**

**GABRIEL BENMOUYAL**

**SCHWEITZER ENGINEERING LABORATORIES, INC.  
LONGUEUIL, QUÉBEC CANADA**

**STANLEY E. ZOCHOLL**

**SCHWEITZER ENGINEERING LABORATORIES, INC.  
HOLLAND, PA USA**

**Presented before the**

**29th ANNUAL  
WESTERN PROTECTIVE RELAY CONFERENCE  
SPOKANE, WASHINGTON  
OCTOBER 22-24, 2002**



# THE IMPACT OF HIGH FAULT CURRENT AND CT RATING LIMITS ON OVERCURRENT PROTECTION

---

Gabriel Benmouyal  
Schweitzer Engineering Laboratories, Inc.  
Longueuil, Québec, CANADA

Stanley E. Zocholl  
Schweitzer Engineering Laboratories, Inc.  
Holland, PA USA

## INTRODUCTION

Current transformers for transmission lines are rated to avoid saturation during the asymmetrical portion of the maximum fault current. Saturation is avoided by selecting an ANSI voltage rating larger than the maximum fault burden voltage with the  $(1+X/R)$  factor applied. This is possible in line protection applications since large load currents result in the use of high ratio CTs, and fault currents are typically limited from 3 to 5, and rarely exceed 10, times the CT primary current rating.

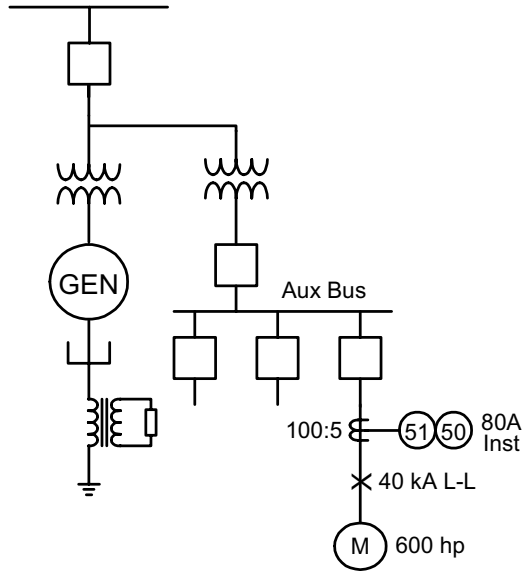
It becomes more difficult to avoid saturation with transformer differential protection. In these applications, the high side CTs tend to be mounted on the transformer bushings and require long lead runs to the relay. The lower current ratio required on the high side of the transformer, together with longer leads, conspires to cause saturation during offset, while the well rated low side CTs have a higher ratio and remain linear. However, the relay detects the second harmonic present in the false differential current and blocks tripping for external faults. Consequently, the ANSI rating can be as low as twice the maximum fault burden voltage rather than applying the  $(1+X/R)$  factor.

Whereas IEEE guides address CT selection for line and differential relays, there is an unfamiliar and neglected area where no guidelines exist. This paper discusses CT ratings used in power plant auxiliaries and related applications where fault currents can exceed 200 times the CT primary current rating. A CT selection criterion is developed for these applications based on a 2-cycle trip time. The paper reviews the limitations of conventional digital filtering used in modern instantaneous overcurrent elements. It also introduces proper digital measurement techniques in order to maintain speed and reliability when instantaneous overcurrent elements are applied with highly saturated current waveforms.

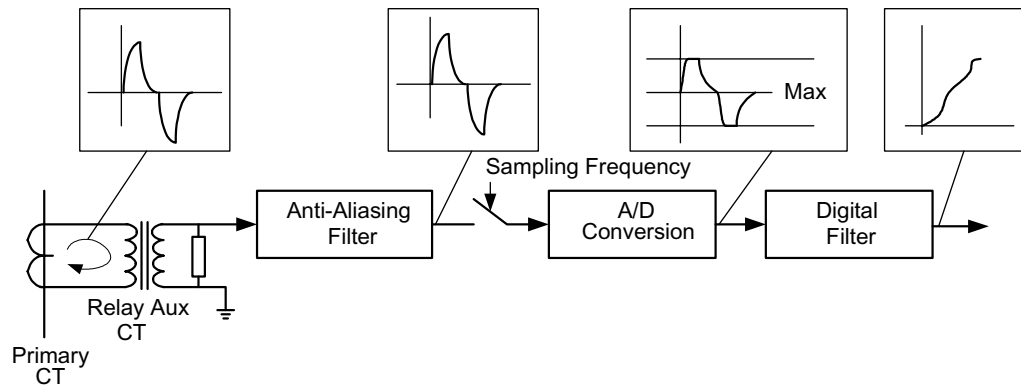
## LIMITATIONS OF AN 80 A INSTANTANEOUS SETTING

Relays protecting power plant auxiliaries may experience fault currents as high as 40 kA, where the  $X/R$  ratio exceeds 20. In addition, low ratio CTs may be used with relays that allow the instantaneous overcurrent element to be set as high as 80 A. What is the response of a relay with an 80 A instantaneous setting, and what are the current waveforms? Are there operating limits? Are there published guidelines? Such an auxiliary bus is shown in Figure 1. These issues are addressed using the following example.

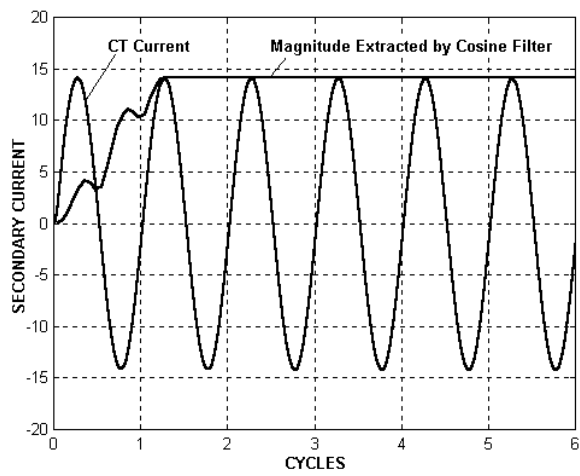
In Figure 1, the 600-hp water pump motor on the plant auxiliary bus uses C50, 100:5 CTs. The motor relay has a motor full load current setting of 6.7 A corresponding to 135 A primary current. The locked rotor setting is 40 A, which is six times the full load current. The instantaneous



**Figure 1** Generator Auxiliary Bus With High Fault Current



**Figure 2** Relay Schematic Showing Measured Signals



**Figure 3** Signal Extracted With a 200 A Primary CT Current

element is set to 80 A, which is twice the locked rotor value. Figure 2 is the schematic diagram of the microprocessor-based relay showing the progression of a signal from analog to digital form. In Figure 2, the relay auxiliary transformer converts the CT secondary current to a scaled voltage signal. The anti-aliasing LPF filter removes any high frequency present in the waveform, and the A/D converter converts the signal to the digital value of the current at a typical sampling rate of 16 samples per cycle. The function of the digital filter is to reject all harmonics and to extract the magnitude of the fundamental content of the signal. Figure 3 shows the extracted fundamental magnitude resulting from a 200 A primary current. The sine wave current and the extracted fundamental magnitude shown in Figure 3 are the expected waveforms. However, what waveform can be expected for the 40 kA fault? Figure 4 shows the severely saturated CT secondary current and the limited magnitude A/D output. What is more, the fundamental extracted from the A/D output falls short of the 80 A trip threshold.

## DEFINING A CT SELECTION CRITERION

The problem associated with high fault current and the 80 A instantaneous setting is shown by the failure to clear the 40 kA fault. The C50, 100:5 CT is clearly inadequate, but what criteria should be used? As a criterion, we will select the CT rating to guarantee a relay trip time in no more than 2 cycles. Using the CT simulation, we can increase standard CT ratings until we obtain the desired result. Figure 5 shows that a C200, 200:5 CT produces a trip time longer than 2 cycles. Figure 6 shows that a C400, 400:5 CT produces a trip time of less than 2 cycles and is the minimum rating that meets the criterion.

The degree of saturation is defined by saturation voltage  $V_S$ , which was derived in Reference 1. In this instance,  $V_S$  was limited to 20 and used as the criterion to avoid saturation. In Reference 2, values of  $V_S$  exceeding 20 were used to define and correlate various degrees of CT saturation to percentage slope settings for low impedance bus differential applications. Here we will base the CT selection criterion on the degree of saturation voltage produced by the 40 kA fault in the C400, 400:5 CT. The equation for the saturation voltage  $V_S$  is:

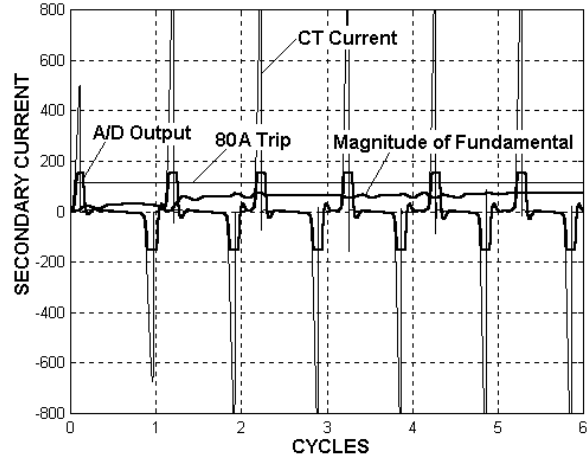
$$V_S \geq \left( \frac{X}{R} + 1 \right) \cdot I_f \cdot Z_b \quad (1)$$

where:

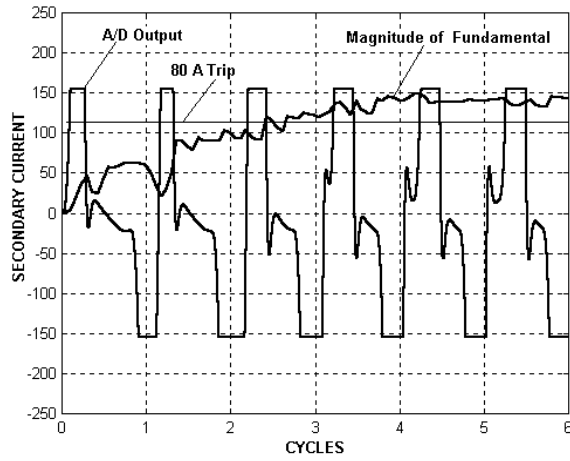
- $I_f$  is the maximum fault current in per unit of CT rating
- $Z_b$  is the CT burden in per unit of standard burden
- $X/R$  is the X/R ratio of the primary fault circuit

Using the 400 A CT primary rating and 40 kA fault current:

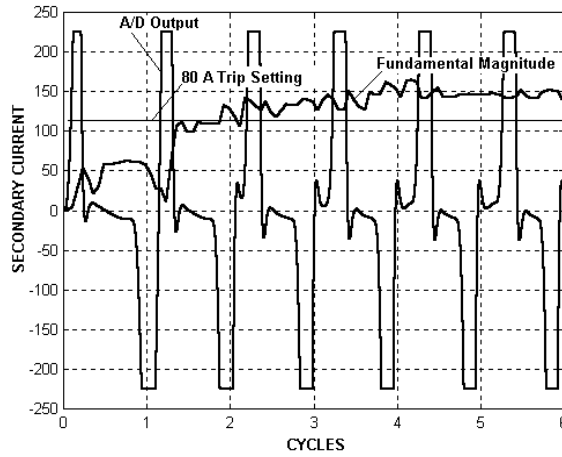
$$I_f = \frac{I_{MAX}}{CT_{RATING}} = \frac{40,000}{400} = 100 \quad (2)$$



**Figure 4** CT and Relay Signals for a 40 kA Fault Using C50, 100:5 CTs



**Figure 5** Response to a 40 kA Fault Using C200, 200:5 CTs



**Figure 6** Response to a 40 kA Fault Using C400, 400:5 CTs

Using the C400 standard burden of 4  $\Omega$  and the actual CT burden of 0.5  $\Omega$ :

$$Z_b = \frac{Z_{\text{Burden}}}{Z_{\text{STD}}} = \frac{0.5}{4} = 0.125 \quad (3)$$

With an X/R ratio of 20:

$$V_s \geq (20 + 1) \cdot 100 \cdot 0.125 = 262.5 \quad (4)$$

Consequently, for power plant auxiliary applications, current transformers used with the microprocessor relay should meet the following criteria:

$$262.5 \geq \left( \frac{X}{R} + 1 \right) \cdot I_f \cdot Z_b \quad (5)$$

where:  $I_f$  is the maximum fault current in per unit of CT rating  
 $Z_b$  is the CT burden in per unit of standard burden  
 $X/R$  is the X/R ratio of the primary fault circuit

The following examples show how the criterion is used.

### **Maximum Fault Current With an 80 A Instantaneous Setting**

Maximum fault current in terms of primary CT and ANSI voltage rating, burden in ohms, and X/R ratio:

$$I_{\text{MAX}} = \frac{262.5}{\left( 1 + \frac{X}{R} \right)} \cdot \frac{\text{ANSI}}{100 \cdot Z_B} \cdot \text{CT}_{\text{RATING}} \quad (6)$$

Example: A microprocessor overcurrent relay has an 80 A instantaneous setting. The relay will be used with a C400, 400:5 CT with a 0.5  $\Omega$  total burden. The X/R ratio is 20. How high can the maximum fault be for secure operation?

The burden is primarily due to the CT windings and external leads to the relay (the microprocessor relay burden itself is negligible):

300 feet full-circuit run of #10 AWG (1.0 $\Omega$ /1000-ft)	0.3
CT winding of 80 turns at 0.0025 $\Omega$ /turn	<u>0.2</u>
Total burden	0.5 $\Omega$

$$I_{\text{MAX}} = \frac{262.5}{\left( 1 + \frac{X}{R} \right)} \cdot \frac{\text{ANSI}}{100 \cdot Z_B} \cdot \text{CT}_{\text{RATING}} \quad (7)$$

$$I_{\text{MAX}} = \frac{262.5}{(1 + 20)} \cdot \frac{400}{100 \cdot 0.5} \cdot 400 = 40,000 \quad (8)$$

## **Minimum CT Rating With an 80 A Instantaneous Setting**

CT rating in terms of maximum fault current, X/R ratio, ANSI rating, and burden:

$$CT_{\text{RATING}} = \frac{\left(1 + \frac{X}{R}\right)}{262.5} \cdot \frac{100}{\text{ANSI}} \cdot I_{\text{MAX}} Z_B \quad (9)$$

Example: With an 80 A instantaneous setting, what is the minimum CT rating that can be used when the maximum fault current is 40 kA, X/R = 20, and the burden is 0.5 Ω:

$$CT_{\text{RATING}} = \frac{\left(1 + \frac{X}{R}\right)}{262.5} \cdot \frac{100}{\text{ANSI}} \cdot I_{\text{MAX}} Z_B \quad (10)$$

$$CT_{\text{RATING}} = \frac{(1+20)}{262.5} \cdot \frac{100}{400} \cdot 40000 \cdot 0.5 = 400 \quad (11)$$

The criterion allows protection engineers to determine the limits of high current applications in terms of the fault current magnitude, the X/R ratio, and relay burden. The criterion addresses the limitation of CT ratings. We must now address the tripping speed.

## **IMPLEMENTING INSTANTANEOUS OVERCURRENT ELEMENTS**

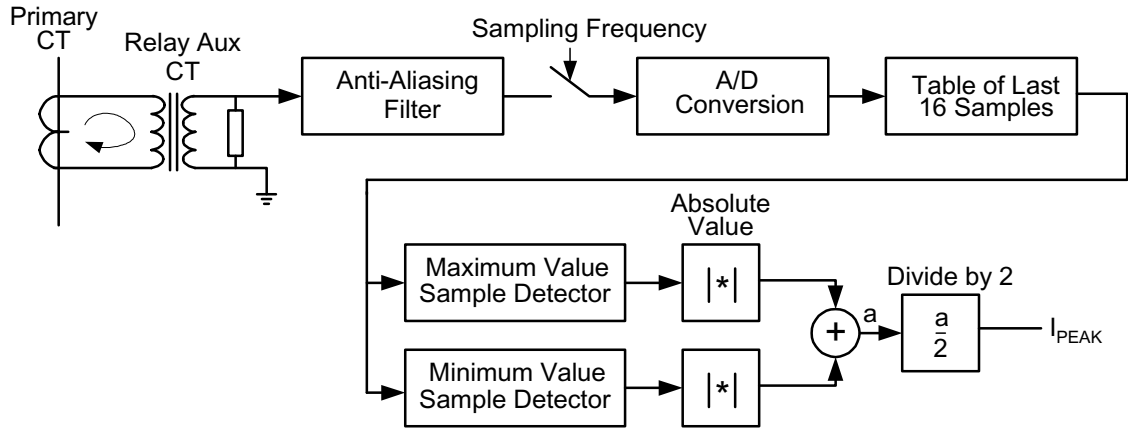
### **Digital Implementation of Instantaneous Overcurrent Relays**

Microprocessor relays use a pair of orthogonal finite impulse response filters for phasor acquisition of current and voltage quantities. Phasors are usually obtained using Fourier or Cosine filters, which eliminate dc and harmonic components, while contributing minimal transient overreach [5, 7].

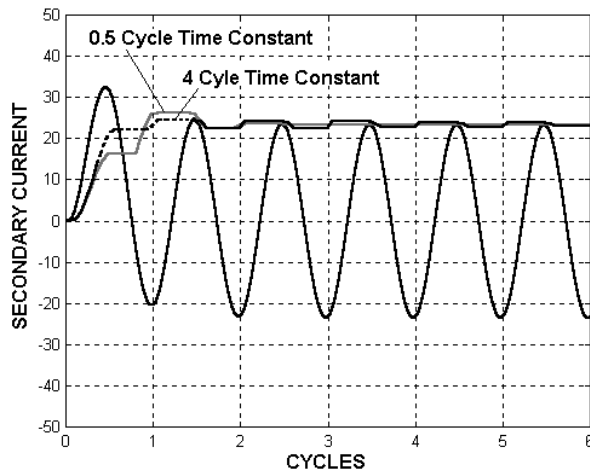
In addition, root-mean-square, peak, or averaging filters can also be realized. Root-mean-square filters respond to the total energy content and respond to the dc component and every frequency present in the waveform. Digital peak detectors also respond to the harmonics and the dc component. Although they are not generally applied, we will discuss the distinct advantage of a peak detector.

Figure 7 shows a variation of the peak detector that has a reduced transient overreach. The filter computes the waveform peak value as the average of the absolute value of two consecutive positive and negative peaks. The maximum transient overreach of 112 percent occurs with a 1-cycle time constant and decreases as the time constant is increased as shown in Figure 8.

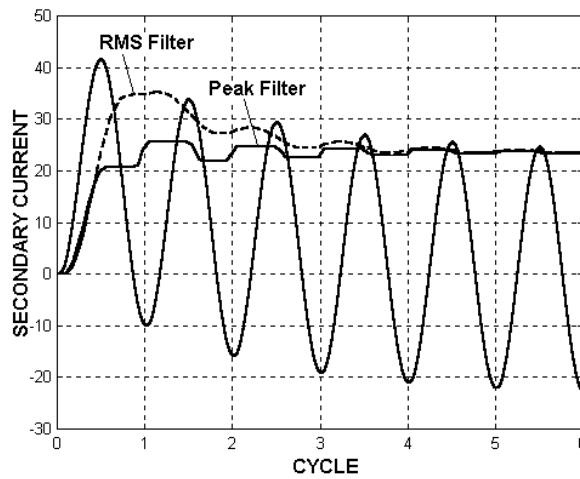




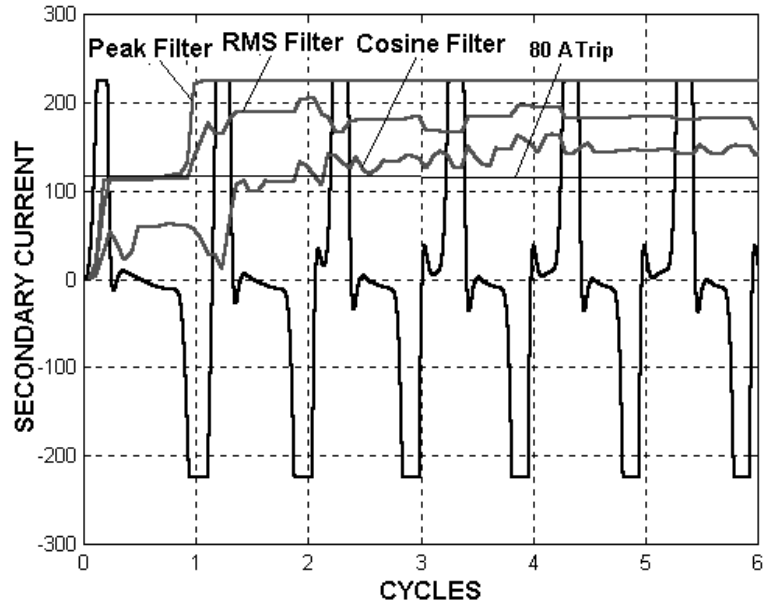
**Figure 7** Diagram of Bipolar Peak Detector



**Figure 8** Bipolar Peak Detector Transient Overreach



**Figure 9** RMS Filter Transient Overreach Compared to Bipolar Peak Filter



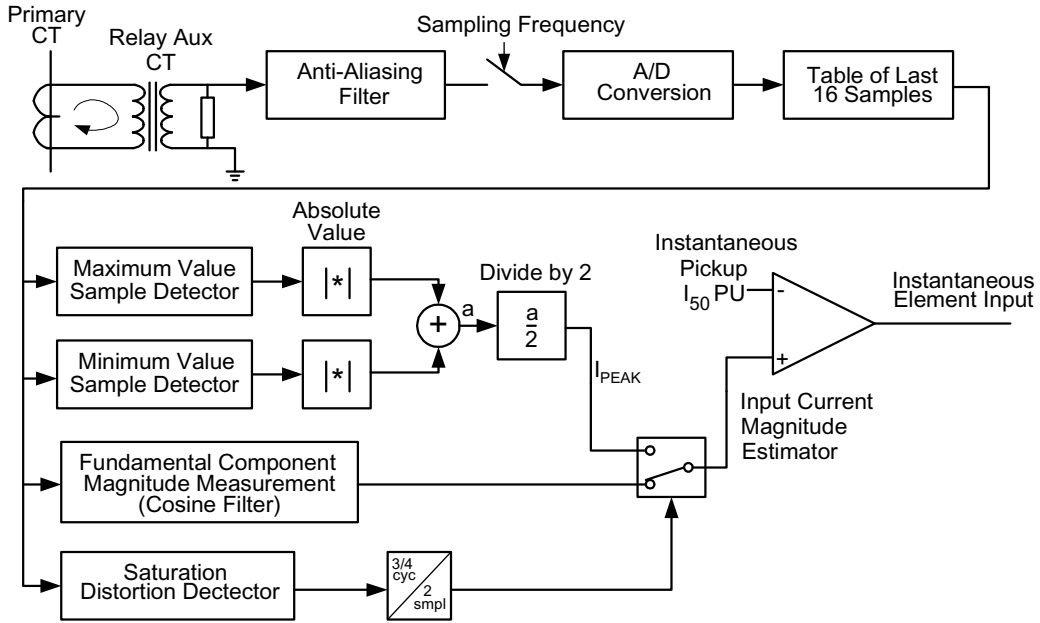
**Figure 10** Filter Response, Fault 40 kA, X/R=20, C100, 200:5 CT, 0.5  $\Omega$  Burden

### Digital Filter Performance With CT Saturation

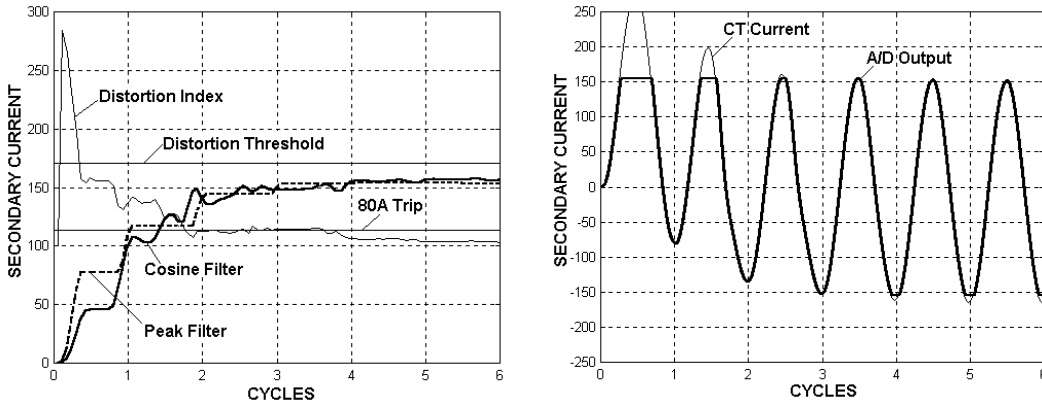
Digital filters cannot make an accurate measurement of fault current once saturation occurs. We have seen, in Figure 3, that the magnitude of the fundamental in a severely saturated current waveform is a poor representation of the actual fault current. However, the fast rising response of the RMS and the peak filter is more representative of the actual magnitude. The responses of the peak, RMS, and Cosine filters are compared in Figure 10. The RMS filter has a fast rising signal but exhibits a prohibitive 150 percent transient overreach because it must respond to dc offset as shown in Figure 9. Of the three filters, the comparison shows that the bipolar peak detector makes the best magnitude acquisition.

### **THE COSINE-PEAK ADAPTIVE FILTER**

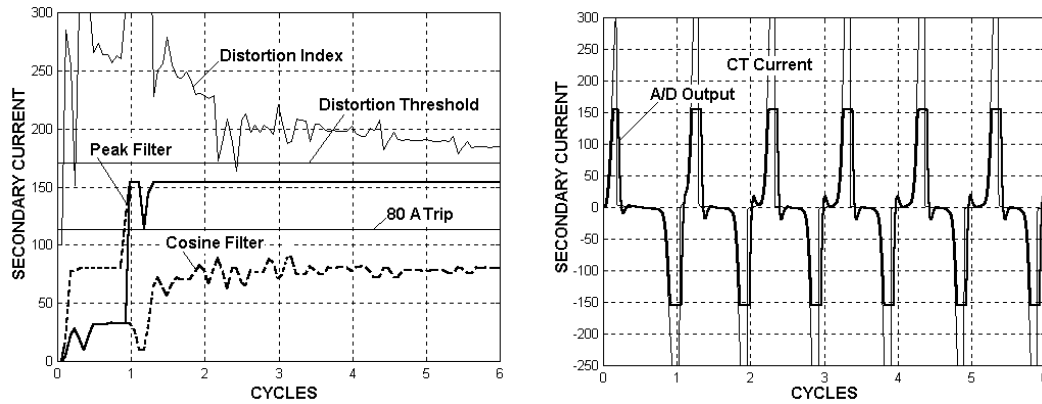
The Cosine filter has an excellent performance with respect to dc offset and removal of harmonics. The bipolar peak detector has the best magnitude acquisition in situations of extreme CT saturation. Combining of the two filters provides an efficient solution for the ideal instantaneous element. This instantaneous element shown in Figure 11 is called a Cosine-Peak Adaptive filter since it incorporates both filters. The Cosine filter supplies the magnitude for normal sine wave operation. The bipolar peak detector provides magnitude for saturated waveforms. A detector measures the degree of saturation by evaluating the level of distortion and switches the input to the bipolar peak detector when the distortion reaches a predetermined value.



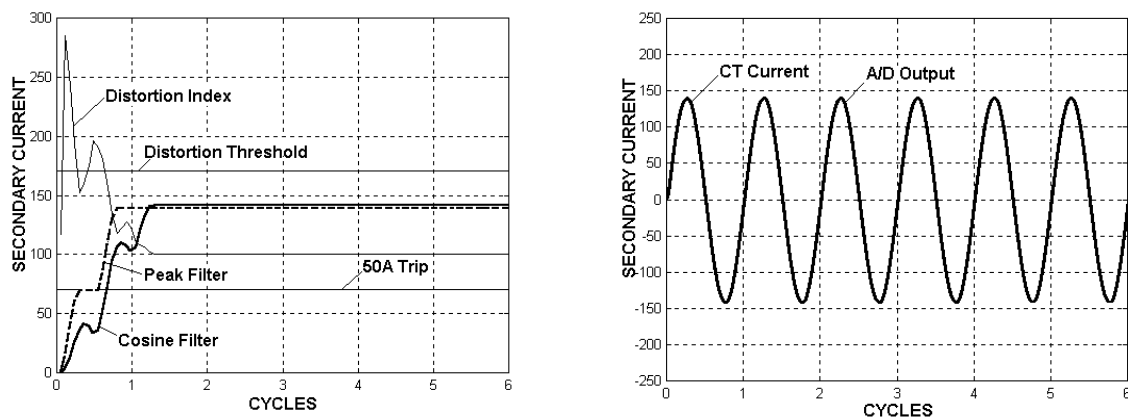
**Figure 11** Instantaneous Element Using the Cosine-Peak Adaptive Filter



**Figure 12** Cosine Filter Providing Trip for a Waveform With Low Saturation  
C400, 200:5, 4500 A Fault With X/R = 11.31



**Figure 13** Bipolar Peak Filter Providing Trip for a Waveform Trip With High Saturation  
C50, 200:5, 20 kA Fault With X/R = 11.31



**Figure 14** Cosine Filter Providing Trip for a Waveform With No Saturation  
C100, 200:5, 4 kA Symmetrical Fault Current

### A Simple Distortion Index

A simple form for the distortion index measures the ratio of the sum of P harmonic magnitudes over the fundamental magnitude:

$$DI = \frac{\sum_{k=1}^P |A_k|}{|A_1|} \quad (12)$$

As an example, if we use the fundamental, the second, and the third harmonic, the formula becomes:

$$DI = \frac{|A_1| + |A_2| + |A_3|}{|A_1|} \quad (13)$$

In this equation, A1, A2, and A3 are the fundamental, second, and third harmonic phasors. For waveforms with no distortion (or no harmonics), the distortion index will be equal to 1. For highly saturated current waveforms, a distortion index of this nature will reach levels greater than 2. The basic concept is then to switch the magnitude measurement from the conventional digital filtering system to the peak detector when the distortion index becomes greater than a fixed threshold. Typically, this threshold will be set at 1.75.

The distortion index is computed sample-by-sample and compared to the threshold. The comparator, in turn, controls a switch. When the distortion exceeds the threshold value, the waveform magnitude measurement is taken from bipolar peak detector output. When the distortion is less than the threshold value, the waveform magnitude is taken from the Cosine filter output. The cases shown in Figures 12 through 14 demonstrate the action of the switch. Figure 12 shows a case of low saturation where distortion index falls below the threshold, and the Cosine filter produces the instantaneous trip. Figure 13 shows a case of high saturation where the instantaneous trip is produced by the bipolar peak filter. Figure 14 shows a case with no saturation where the distortion index settles below the distortion threshold, and the Cosine filter provides the measurement. The distortion index registers a high initial value in response to an abrupt change but settles quickly to the correct value. The security timer overrides the settling time to assure an accurate measurement.

## CONCLUSIONS

1. High-set instantaneous settings and high fault current magnitude limit CT ratings.
2. Instantaneous elements should respond to peak current to assure fast tripping with extremely high fault current in the presence of CT saturation.
3. In the absence of CT saturation, instantaneous elements should respond to the fundamental to eliminate dc offset and standing harmonics.
4. A distortion index supervised peak provides tripping speed during saturation during dc offset and allows fundamental response for unsaturated waveforms.

## REFERENCES

- [1] S. E. Zocholl, G. Benmouyal, and J. Roberts, "Selecting CTs to Optimize Relay Performance," 23<sup>rd</sup> Annual Western Protective Relay Conference, Spokane, WA, October 15-17, 1996.
- [2] S. E. Zocholl, "Rating CTs for Low Impedance Bus and Machine Differential Applications," 27<sup>th</sup> Annual Western Protective Relay Conference, Spokane, WA, October 24-26, 2000.
- [3] S. E. Zocholl and D. W. Smaha, "Current Transformer Concepts," Proceedings of the 46<sup>th</sup> Annual Georgia Tech Protective Relay Conference, Atlanta, GA, pp. 7-9, April 29-May 1, 1992.
- [4] S. E. Zocholl and G. Benmouyal, "How Microprocessor Relays Respond to Harmonics, Saturation, and Other Wave Distortions," 24<sup>th</sup> Annual Western Protective Relay Conference, Spokane, WA, October 21-23, 1997.
- [5] E. O. Schweitzer III and Daqing Hou, "Filtering for Protective Relays," 19<sup>th</sup> Annual Western Protective Relay Conference, Spokane, WA, October 20-22, 1993.
- [6] IEEE Std C37.110-1996, IEEE Guide for the Application of Current Transformers Used for Relaying Purposes.
- [7] G. Benmouyal, "Removal of DC-Offset in Current Waveform Using Digital Mimic Filtering," IEEE Transactions on Power Delivery, Vol. 2, No. 2, pp. 621-630, April 1995.

## BIOGRAPHIES

**Stanley (Stan) Zocholl** has a B.S. and M.S. in Electrical Engineering from Drexel University. He is an IEEE Life Fellow and a member of the Power Engineering Society and the Industrial Application Society. He is also a member of the Power System Relaying Committee and past chair of the Relay Input Sources Subcommittee. He joined Schweitzer Engineering Laboratories in 1991 in the position of Distinguished Engineer. He was with ABB Power T&D Company Allentown (formerly ITE, Gould, BBC) since 1947, where he held various engineering positions, including Director of Protection Technology.

His biography appears in Who's Who in America. He holds over a dozen patents associated with power system protection using solid state and microprocessor technology and is the author of numerous IEEE and Protective Relay Conference papers. He received the Best Paper Award of the 1988 Petroleum and Chemical Industry Conference and the Power System Relaying Committee's Distinguished Service Award in 1991.

**Gabriel Benmouyal** received his B.A.Sc. in Electrical Engineering and his M.A.Sc. in Control Engineering from Ecole Polytechnique, Université de Montréal, Canada, in 1968 and 1970, respectively. In 1969, he joined Hydro-Québec as an instrumentation and control specialist. He worked on different projects in the field of substation control systems and dispatching centres. In 1978, he joined IREQ, where his main field of activity was the application of microprocessors and digital techniques to substation and generating-station control and protection systems. In 1997, he joined Schweitzer Engineering Laboratories in the position of Research Engineer. He is a registered professional engineer in the Province of Québec, is an IEEE member, and has served on the Power System Relaying Committee of IEEE since May 1989.