

# Synchrophasor-Based Power System Protection and Control Applications

Edmund O. Schweitzer III, David Whitehead,  
Greg Zweigle, Krishnanjan Gubba Ravikumar  
*Schweitzer Engineering Laboratories, Inc.*

**Abstract**—Synchrophasor data consist of analog and digital values with an associated precise time stamp. With precise time, these quantities are collected from various locations, time-aligned, and then processed as a coherent data set. Synchrophasors have generally been used for visualization and post-event analysis. However, new technologies allow synchrophasors to be processed in real time. Synchrophasor systems are now being used for real-time wide-area protection and control.

This paper examines several ways synchrophasors are being used:

- Voltage stability detection and correction
- Load/generator shedding
- Islanding control
- Intermittent generation source control and grid interconnection

Each application includes a discussion of how synchrophasors provided a unique solution and benefit over traditional solutions. Application performance, speed, data requirements, and equipment are also reviewed. We also discuss a future time-synchronized control solution.

## I. INTRODUCTION

Utilities worldwide are deploying synchrophasor systems to monitor and analyze power system behavior. NERC CEO Rick Sergel has said synchrophasors are “like the MRI of the bulk power system” [1]. But monitoring and post-event analysis are only the first applications of synchrophasors.

With new advances in processing and equipment, synchrophasors are now used to solve a variety of power system protection, automation, and control problems. They are being used to operate and manage the power system. Applications include voltage stability assessment, islanding distributed generation, control based on small signal instability detection, and system-wide disturbance monitoring [2]. In addition to showing application examples, this paper introduces a time-coordinated control scheme that improves system reliability by reducing unnecessary system variations.

With all the recent efforts to make the power system grid more efficient and “smarter,” synchrophasor-based control is a core smart-grid technology. As this paper will show, synchrophasor-based protection, automation, and control solutions actually require less system data and provide crisper results than traditional methods.

## II. SYNCHROPHASOR CONTROL SYSTEMS

Control systems consist of a desired operating point, measurements of the physical system, a control algorithm, and control devices to modify the physical system.

Desired operating points for power system control include voltage and current levels, frequency, and power flows. Measurements include voltages, currents, frequency, breaker positions, and transformer tap positions. Control algorithms vary from simple threshold comparators that trigger the transformer load tap changer (LTC), to classical control algorithms, such as proportional integrals and proportional integral derivatives that control a generator governor, to more sophisticated algorithms, such as fuzzy logic or neural networks used to control a power system stabilizer. The control algorithm drives the physical system to the desired operating point. Control devices include circuit breakers, capacitor banks, tapping transformers, and generator governors.

Control systems, like the one shown in Fig. 1, have typically used local measurements because control algorithms rely on a coherent set of data, i.e., for the control algorithms to function properly, the data must be from the same instant in time. This is a simple process if the data inputs are geographically close to the control device. For example, an LTC control, using local voltages and currents, processes the measurements and adjusts the tap position. However, the task of deterministically optimizing the voltage profile across a large geographic area using multiple LTCs requires exchanging wide-area information. SCADA-based voltage profile controls lack the real-time voltage and absolute angle information to perform precise, real-time wide-area voltage control.

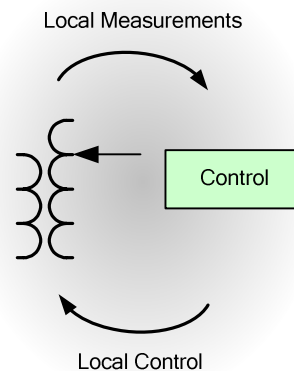

Fig. 1. Local Power Control System

Synchrophasors solve the time-incoherence of distributed data by time-stamping the data and then aligning measurements to a common time reference for processing. The concept of a time-synchronized wide-area power control system is

shown in Fig. 2. This system uses a Synchrophasor Vector Processor (SVP) for synchronized wide-area control [3].

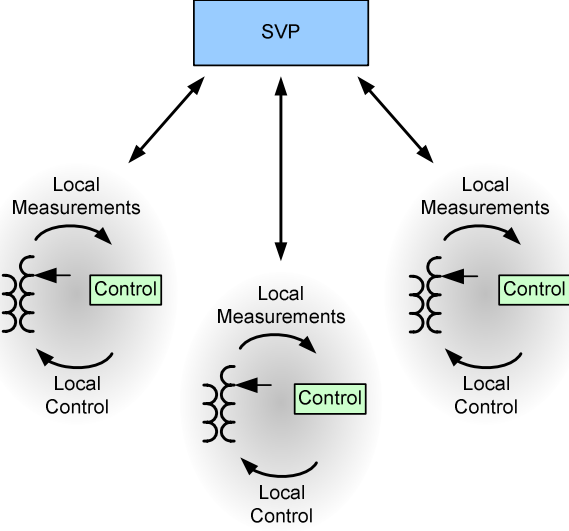

Fig. 2. Wide-Area Power Control System

In Fig. 2, synchrophasor data are sent from the local power system to the SVP. The SVP time aligns the data, assesses the entire system voltage profile, and sends optimized voltage set points to each LTC control. Synchrophasors and time-deterministic control provide benefits over traditional local control including faster control loops and coordinated switching, which result in improved power quality and reduced equipment wear.

Utilities are designing and implementing new methods for power system control using power system equipment capable of producing, transporting, and processing synchrophasor data, e.g., SVPs, relays, meters, phasor measurement units (PMUs), and communications systems. Fig. 3 shows inter- and intrastubation networks using synchrophasors for power system control. Examples of synchrophasor intrastubation applications include backup bus protection and substation diagnostics. Inter-substation applications include load shedding and modal analysis [2].

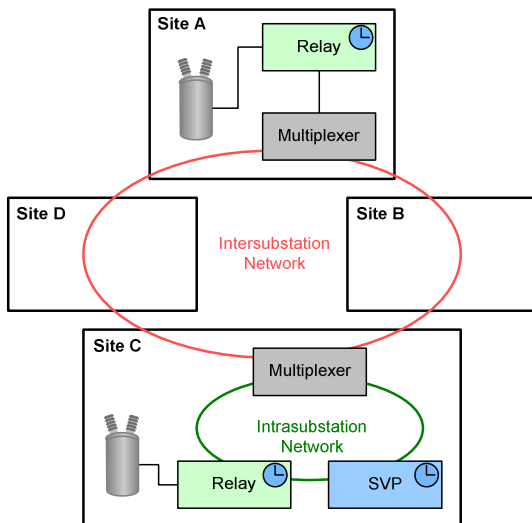

Fig. 3. Synchrophasor-Based Inter- and Intra-substation Networks

### III. WIDE-AREA CONTROL USING TIME-SYNCHRONIZED PHASORS

The following section describes some of these new synchrophasor-based systems that are being used to solve problems that either would not be economically feasible or could not have been done using traditional methods.

#### A. Voltage Stability Detection and Mitigation [4]

A portion of the Eskom power system in South Africa is vulnerable to voltage collapse. To avoid voltage collapse and maintain power system stability, Eskom used a traditional load-shedding scheme, which solved the voltage problem. However, by the time a problem was detected, the load-shedding scheme had caused a large amount of load to be dropped.

A real-time detection and mitigation system using synchrophasors allows Eskom operators to prevent voltage collapse and minimize load shedding. The system gathers synchrophasor data using an SVP that accurately calculates the state of the power system. The SVP sends the system state and network data to a computer that calculates voltage collapse indices. One index is the margin from voltage collapse, which is calculated using the reactive power voltage margin (QVM). It is given by (1) in relation to a specific bus ( $bus_j$ ),

$$QVM = Q_{Maximum} - Q_{Operating} \quad (1)$$

where:

$Q_{Operating}$  is the measured reactive power at  $bus_j$ , and  
 $Q_{Maximum}$  is the maximum reactive power threshold at  $bus_j$

The QVM is the minimum inductive load necessary to cause a voltage collapse under steady-state power flow conditions.

Another index used in the voltage stability analysis is Incremental Reactive Power Cost (IRPC). The IRPC represents the reactive power that is needed by the reactive power sources to feed each additional MVAR at  $bus_j$ . In [4] it is given by

$$IRPC_j = \sum_{k=1}^n \frac{\Delta Q_{gen_k}}{\Delta Q_{bus_j}} \quad (2)$$

where:

$\Delta Q_{gen_k}$  is the change in the  $k^{th}$  generator reactive power output for a small change in the reactive power load at the bus,

$\Delta Q_{bus_j}$  is the reactive power load at the bus, and

$n$  is the number of reactive power sources.

IRPC is an indication of proximity to voltage collapse. In Fig. 4, the system is close to voltage collapse at Step 3 when the IRPC changes from 1.4 at the base to 2.7.

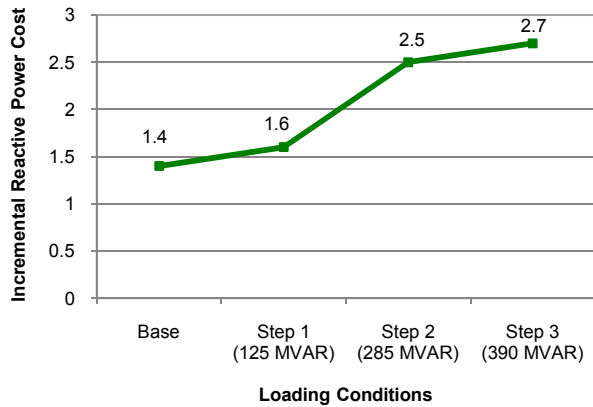

Fig. 4. QV IRPC Behavior for Different Loading Conditions [4]

The detection and mitigation system indices enable Eskom to determine power system proximity to voltage collapse and propose an effective load-shedding scheme prior to voltage collapse.

Eskom's real-time voltage stability detection and mitigation system is shown in Fig. 5. Here PMUs collect and send the network power system data to an SVP at a rate of one message per second. The SVP time aligns the synchrophasor measurements and feeds them into a computer running the voltage collapse prediction algorithm. The computer sends the calculated indices back to the SVP within one second for further visualization and control. If the indices show that an immediate action is required to avoid voltage collapse, then the SVP issues load-shedding commands to known weak buses using the automatic control. If the indices show a potential problem, then the SVP visually alarms the operator who may issue a load-shedding command at the major interconnect through manual control. The result is a system that minimizes customer impact while responding to voltage stability issues.

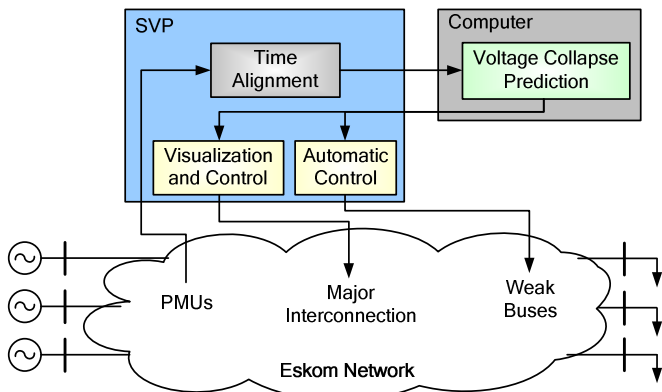

Fig. 5. Eskom's Real-Time Voltage Stability Detection and Mitigation System

### B. Governor Mode Control

Abbott Pharmaceuticals in Puerto Rico is upgrading their distribution system to enhance reliability. The upgrade is designed to enable islanding of critical plant loads on the cogeneration system by detecting disturbances on the power grid. The upgrade separates cogeneration from the grid at selected points in the plant distribution system, depending on production and load at the time of the disturbance. For such an appli-

cation, it is necessary to determine when the cogeneration system is connected to the grid. When connected, the grid controls the system frequency, and the governor controls the power output of the generator. When the generator is operating in an island, the governor must be switched to isochronous mode to regulate frequency.

The original system used nontime-aligned frequency data to detect synchronism. This method is susceptible to false declaration of synchronism when the two systems operate at nearly the same frequency but are not connected. Using angle information in addition to frequency to determine if an island condition has occurred is a more reliable method. However, typical systems are not capable of determining angle differences between points in a power system due to the lack of a common time reference for the analog data. Synchrophasors provide time-stamped vector data to determine absolute angles across a power system.

For the upgrade, Abbott Pharmaceuticals is using a previously installed substation relay with PMU capability to communicate time-aligned frequency and angle measurements of the utility system to another relay capable of processing synchrophasor data at the cogeneration control room. See Fig. 6. By communicating both frequency and angle measurements, the system is able to automatically switch the governor control mode when it detects separation.

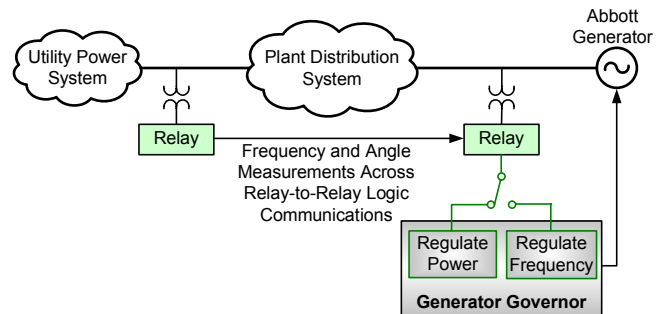

Fig. 6. Frequency and Angle Measurements Across Relay-to-Relay Logic Communications Link

Dedicated fiber, already in use for relay-to-relay logic communications, was used to communicate time-aligned synchrophasor data between the IEDs. This upgrade not only improved system reliability but was very economical because the synchrophasor processing capability was built into the existing relays. The only additional equipment required was a GPS time clock at the remote relay.

Fig. 7 shows the relay logic used for calculating slip frequency and angle difference. The relay uses the absolute values of slip and angle difference to detect synchronism, as shown in Fig. 8. The logic input, Remote Voltage Valid, asserts when the utility voltage is present. If the voltage is not present, then the generator is islanded. The GPS Valid input asserts when the GPS signal is valid for synchrophasor use. If the GPS signal is valid and voltage is present at the utility site, then Abbott uses both the slip and the angle difference between the utility and their facility to determine if an island condition exists. In the event that the GPS signal is not valid, the logic bypasses the angle check and operates based only on nontime-aligned slip measurements, as it did prior to the reliability system upgrade.

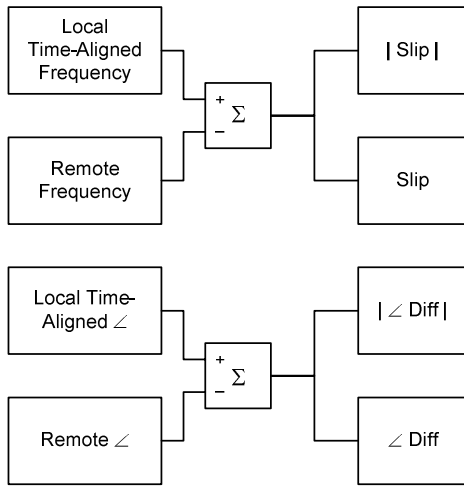

Fig. 7. Slip Frequency and Angle Differences Processed by Relays

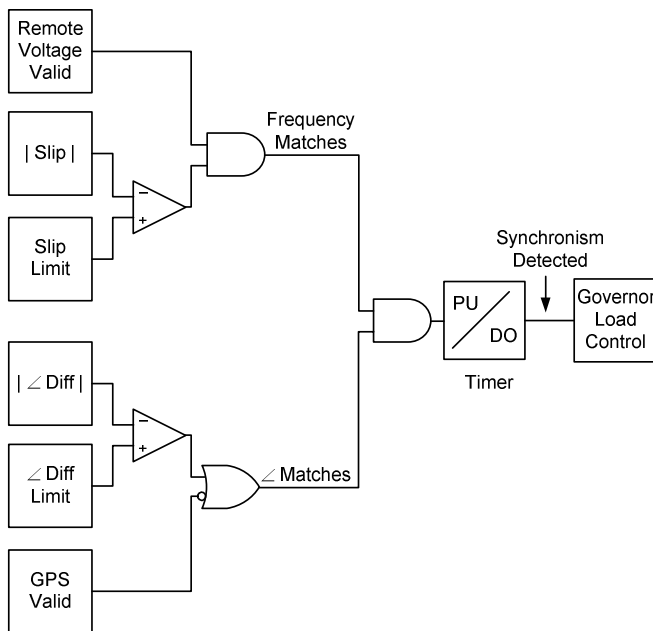

Fig. 8. Synchronism Detection Logic

### C. Distributed Generation Control

Photovoltaic (PV) systems are generating interest due to government investment and a desire to develop alternative energy sources. For PV sources to be widely accepted, there must be reliable means to interconnect them to the bulk power grid. PV Powered, a manufacturer of grid-tied solar inverters, has assembled a team (Sensus, Northern Plains Power Technologies, Portland General Electric, and SEL) to address the challenges associated with the integration of solar distributed generation onto the bulk power grid. The effort is funded by the US Department of Energy under the Solar Energy Grid Integration System program.

One issue the team is addressing is islanding. When a source is islanded from the bulk transmission system, the source must also disconnect from the islanded portion of the electric network. Failure to trip the source could risk personnel safety, power quality, and out-of-phase reclosing.

IEEE 1547 Standard for Interconnecting Distributed Resources With Electric Power Systems [5] defines the require-

ments for integrating distributed sources to a bulk power grid. IEEE 1547 specifies that a source must disconnect from the islanded system within two seconds. Traditional methods that use only local measurements for island detection may not detect islanding soon enough for all load/generation conditions. Synchrophasors enable precise wide-area measurements and therefore provide a means for detecting islanding under nearly all load/generation conditions.

The traditional approach to detecting islanding uses local voltage and frequency information to check if the frequency or voltage magnitude is outside predetermined thresholds. However, local detection schemes cannot detect islanding in a timely manner if the power (real and reactive) mismatch between the source and the local load is small. Other traditional schemes rely on breaker status communication, open phase detectors, and trip commands to detect islanding and isolate the source. Such schemes are simple in concept, but they must adapt to topology changes in the power system. These adaptation requirements can result in a system with many communications links and poor reliability.

Another limitation to traditional approaches is their inability to scale with future requirements. For example, IEEE 1547 requires disconnection for sagging voltage under high demand. With a small amount of generation, such a requirement is reasonable, but disconnecting a high-density solar generation source will further aggravate the low-voltage level. The wide-area view provided by synchrophasors provides a platform for solutions that keep the generation online during transient conditions.

A synchrophasor-based detection method overcomes the limitations of traditional approaches. Fig. 9 shows an anti-islanding scheme for a solar generation facility, which is based on a recent algorithm developed for anti-islanding with synchronous generation [6] and has many features that are applicable to the inverter of a solar generation system. Both bulk power system and distributed generation locations supply data for the algorithm.

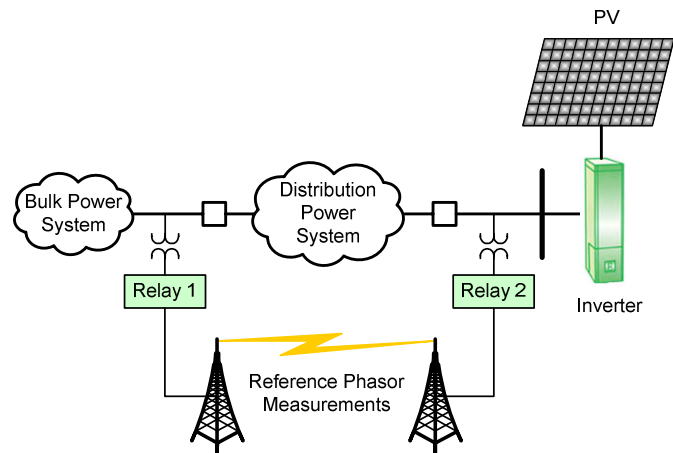

Fig. 9. Anti-Islanding Scheme Using an Inverter

Both relays in Fig. 9 acquire voltage phasor measurements from their corresponding sites. Relay 1 sends the synchrophasor messages to Relay 2 at specific time intervals (60 messages per second). Relay 2 receives the remote synchrophasor data

from Relay 1 and calculates the difference between the local and remote synchrophasor angle value, which is defined as  $\delta_k$ . The change of  $\delta_k$  with respect to time defines the slip frequency,  $S_k$ , and the change of slip frequency with respect to time defines the acceleration between the two terminals,  $A_k$ . These measurements are defined as follows:

$$\delta_k = \angle V_k^{(1)} - \angle V_k^{(2)} \quad (3)$$

$$S_k = (\delta_k - \delta_{k-1})\text{MRATE} \quad (4)$$

$$A_k = (S_k - S_{k-1})\text{MRATE} \quad (5)$$

where:

$\angle V_k^{(1)}$  is the positive-sequence voltage angle of Relay 1 at the  $k$  processing interval,

$\angle V_k^{(2)}$  is the positive-sequence voltage angle of Relay 2 at the  $k$  processing interval,

$S_k$  is the slip frequency at the  $k$  processing interval,

$A_k$  is the acceleration at the  $k$  processing interval, and

MRATE is the synchrophasor message rate.

This wide-area scheme combines two methods for islanding detection, the Angle Difference Method and the Slip-Acceleration Method.

#### 1) Angle Difference Method

In this method, the relay compares the angle difference,  $\delta_k$ , against an angle threshold (20 degrees, for example). If  $\delta_k$  is greater than the threshold and longer than a predefined time, the logic declares an island condition and sends a trip command to the source breaker.

Angle difference can be viewed as an integration of frequency difference. When the frequencies of two disconnected systems are different, then the angle difference between the systems grows. Time-synchronized phasors enable calculating this angle difference using the time stamp recorded at the exact instant of the phase measurement.

Time-synchronized measurements also enable an exact local nominal frequency calculation. Each relay can then compare the local frequency against a numerically calculated reference frequency. This is the concept behind a synchrophasor-based time-error measurement for islanding detection [7]. Equation (6) shows the time-error measurement calculation.

$$\text{TE}_k = \text{TE}_{k-1} + \frac{1}{f_{\text{NOM}}} (f_k - f_{\text{NOM}}) \Delta t \quad (6)$$

Frequency is the derivative of phase and therefore (6) is effectively a phase-error calculation, referenced against an ideal phase angle at frequency  $f_{\text{NOM}}$ . When the time-error measurement is communicated between the relays and subtracted, the result is a quantity proportional to the angle difference. When using angles directly or the time-error measurement, comparing the quantity against a threshold provides an indication of the islanding condition.

This indication works even when the frequency difference between the two systems is small and therefore the slip is small. The slip-acceleration method, described next, gives

another indication for cases when the frequency difference is not small.

#### 2) Slip-Acceleration Method

The second method monitors the rate-of-change of phase. The rate-of-change of phase is defined as the slip ( $S_k$ ), and the rate-of-change of the slip is defined as acceleration ( $A_k$ ) between two points in a power system. Combining slip and acceleration creates the island-detection characteristic shown in Fig. 10. In steady state, the frequency of the connected systems is the same at the two measured points; the slip and acceleration are zero and the operating point is at (0, 0) of the island-detection characteristic. When a source separates from the bulk power system, generally there will be both slip and acceleration. The magnitude of either can push the operating quantity into the operate region of the characteristic.

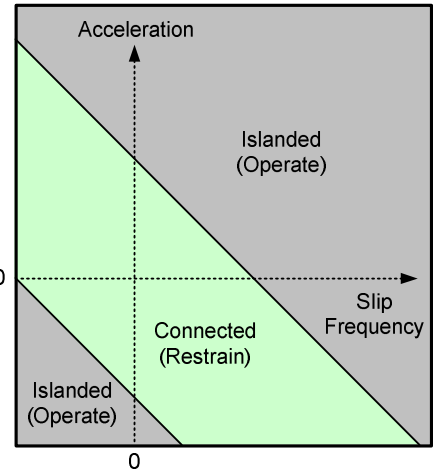

Fig. 10. Operate and Restrain Regions of the Island-Detection Characteristic

Response time is an important feature of any islanding scheme. Fig. 11 shows simulation results comparing an islanding scheme that uses local measurements with an islanding scheme that uses wide-area synchrophasor measurements [6].

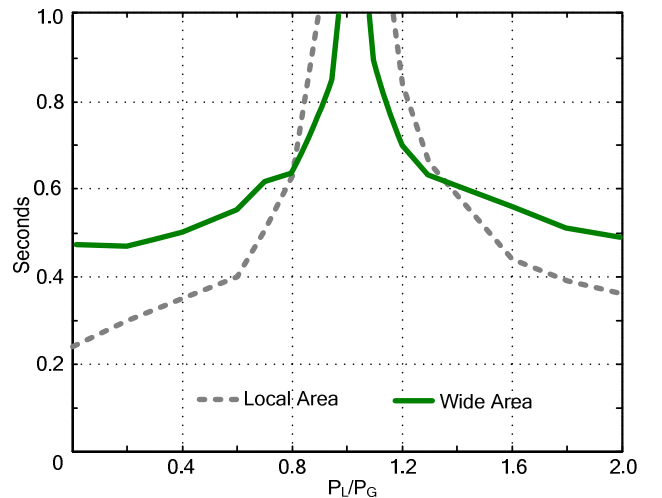

Fig. 11. Wide-Area Scheme Detects Islanding for All Power Exchange Conditions

The response time to detect the island is plotted as a function of the ratio between load and generation during the is-

landed condition. As generation and load become more evenly matched, islanding detection becomes more difficult for all schemes. The local scheme consists of overfrequency, underfrequency, overvoltage, and undervoltage elements. Additionally, a frequency vs. rate-of-change of frequency characteristic defines islanding regions in cases where high or low frequency occurs simultaneously with high or low rate-of-change of frequency [6].

Fig. 12 shows that for a system using wide-area measurements, the response time includes communications latencies.

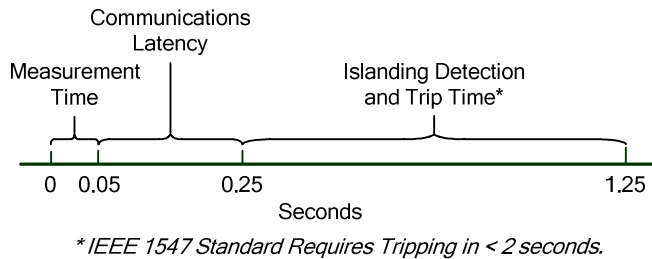

Fig. 12. Total Time to Detect Islanding and Trip Is 1.25 Seconds Using a Synchrophasor Wide-Area Measurement Scheme

In Fig. 12, the measurement time is due to the filtering delays of the relay with PMU capabilities. Filtering delays can be as fast as 16 milliseconds, with 50 milliseconds being selected for the simulation in Fig. 12. The communications latency depends on the communications scheme. For distributed solar generation schemes, the communications latency is impacted by the need to coordinate the reference measurement (Relay 1 in Fig. 9) with multiple generation locations. In Fig. 12, a quarter second is allocated to the communications system. Finally, based on simulation results, one second is allocated to the islanding detection algorithm. This leaves three quarters of a second of margin to achieve a total response time of less than two seconds, the required time in IEEE 1547.

Combining local and wide-area measurements creates a fast islanding detection scheme under normal communications link conditions, and it still performs if a communications link is down.

#### D. System Oscillation Detection

On March 18<sup>th</sup>, 2009, wind generation in Texas exceeded 20 percent of total demand [8]. This significant change in power transfers caused large voltage variations in the system resulting in angle swings. Widely varying power transfers can lead to undamped oscillations and drive the system toward instability. To prevent such system collapse, synchrophasor-based schemes have been developed to detect impending unstable operating conditions and alarm system operators. Time-synchronized phasors are sampled at high rates that enable seeing relatively fast power variation transients caused by renewable generation.

One method of measuring undamped oscillations is modal analysis. Modal analysis is a signal-processing technique that requires uniformly spaced samples. Because of this, the asynchronous nature of traditional data acquisition systems is not suitable. Synchrophasor systems sample uniformly. Off-line modal analysis is possible using prerecorded system samples;

however, unlike with synchrophasors, these are not real-time systems. Synchrophasor systems are real time.

Measuring the modes provides valuable information about the frequency and damping of power system oscillations. This tool is uniquely matched to provide metrics about the inherently dynamic nature of the power system. The University of Texas uses an SVP for performing modal analysis between two locations in Texas. Fig. 13 shows the location of PMUs and the SVP. Location 1 is the wind generation site, and Location 2 is the University of Texas at Austin. The PMUs at both locations send positive-sequence voltage measurements to the SVP at 30 messages per second. The information is received by the SVP and time aligned. Using this time-aligned information, the SVP can compare modes between the two locations. Modal analysis provided by the SVP gives the ability to observe the power transfer behavior for various conditions such as high wind penetration and generation unit trip. Control algorithms are being developed that use these calculated system modes as inputs.

Synchrophasors provide the opportunity to visualize the system response to sudden events (which occur frequently with wind generation) and to determine the types of responses that are typical for a power system, compared to those that could signal an impending problem.

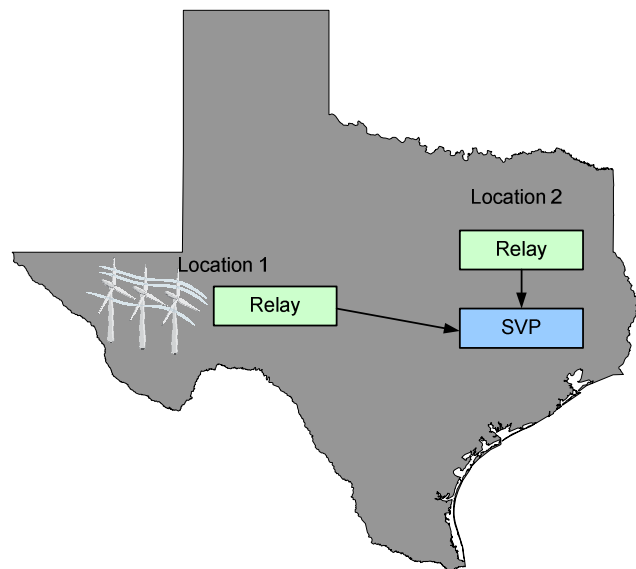

Fig. 13. Texas Synchrophasor-Based Modal-Analysis System

#### IV. FUTURE SYNCHROPHASOR CONTROL

Today, many power system control functions are performed with operator intervention. While this manual method has provided satisfactory results, automating these functions is now possible using RECIPE technology. RECIPE technology uses synchrophasor measurements to synchronously automate and control power system events using a series of predetermined, time-coordinated instructions. These instructions are based on the desired state and actual measured state of the power system.

To illustrate this technology, assume a transmission line must be removed for maintenance. Currently, after all the necessary permissions and approvals are obtained, the switch

order goes out. First the operator opens one breaker, verifies it is open, and then subsequently the second is ordered opened and verified. With the opening of the circuit breakers, the power system balance is disturbed, and it transitions to a new operating point. For example, the voltage at the load may have decreased and, as a result, LTCs may tap, capacitor banks may insert, or other similar voltage control mechanisms may operate to restore balance due to the loss of the transmission line. Using RECIPE technology, IEDs take predetermined control actions to efficiently open the line and minimize power system disturbances. In the transmission line illustration, we can determine what effect the loss of the line will have on the power system and determine what equipment should be preset to minimize these conditions. Further, using synchrophasors and time-deterministic communications, we can precisely coordinate events, such as breaker operation and LTC tapping, to minimize power system disturbance.

A RECIPE requires action from multiple power system devices. The engineer breaks the RECIPE into parts or sub-RECIPES. The automation controller sends the sub-RECIPES to various IEDs as shown in Fig. 14.

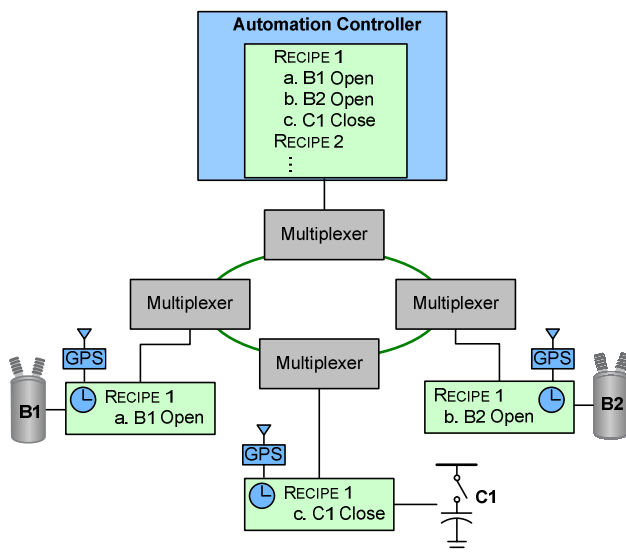

Fig. 14. RECIPE Control System

At predetermined times, the IEDs execute their sub-RECIPE to achieve the desired outcome. Each sub-RECIPE includes local checks to ensure that power system conditions are within acceptable operating parameters, that an override command has not been issued to halt the RECIPE action, and other similar checks to ensure automated actions are not taken at an inappropriate time.

The following is an example of RECIPE executions.

1. The operator selects a RECIPE designed to perform a desired operation and sends it to an automation controller.
2. The automation controller, with the master RECIPE list, sends the sub-RECIPE to each IED required to perform a function in the overall RECIPE scheme.
3. Each IED returns its status to ensure it is ready and that the associated equipment is not faulty. If the IED reports that it is not ready, the RECIPE process is halted.

4. After receiving confirmation from the IEDs that the sub-RECIPE is ready to run, the automation controller indicates to the operator that the RECIPE and associated IEDs are ready and waits for an operator verification to initiate the RECIPE.
5. The operator verifies that this RECIPE is the proper RECIPE to run, sends the time the RECIPE is to run, and arms the system. The verification step provides security against unauthorized power system control operations.

To further illustrate RECIPE technology, let us look again at the transmission line removal example. The one-line diagram of the electric power delivery system in Fig. 15 illustrates some redundancy in the transmission of electric power between bus B1 and bus B2 using transmission lines 1 and 2. The utility operator wants to take transmission line 1 out of service, requiring transmission line 2 to carry all the electric power required for the loads at B2 and B3.

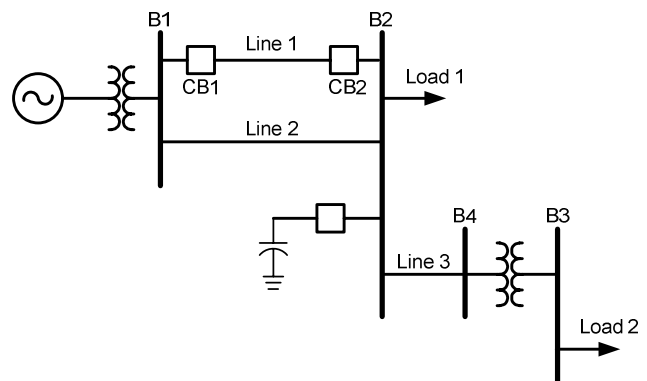

Fig. 15. Power System Model to Analyze RECIPE Technology in Real Time

Increasing the load on a single transmission line has certain foreseeable consequences. For example, removing one transmission line will cause the other line to carry more power to the load. Due to increased current and increased impedance resulting from only one line in service, the voltage at the load will drop. These changes will further affect the real power and reactive power that are delivered over the single transmission line. Because voltage and reactive power need to be kept within certain limits for safe and reliable power delivery, voltage regulators in the delivery system may need to make tap position changes as a result of the change in voltage. Capacitor banks may need to be switched on or off to maintain a proper balance of reactive power delivery.

Thus, removing transmission line 1 from service, while maintaining safe and reliable electric power delivery to the loads, requires more than simply opening circuit breakers CB1 and CB2. Once those circuit breakers are opened, it requires measuring the current on transmission line 2, monitoring voltages, currents, real power, and reactive power on the delivery side to the loads, and controlling voltage regulators and capacitor banks to balance the electric power that is ultimately delivered. Further, the operation of the voltage regulators and capacitor banks may affect the power system conditions, necessitating further tap changes of voltage regulators or switching on or off of capacitor banks. Such shifting and balancing

of the electric power system causes wear and tear on the equipment and sags and swells in power delivery to loads. However, this shifting and balancing of power system conditions is not necessary. The reaction to the removal of the transmission line is predictable, so a power system engineer can predict what actions would need to take place once the line is removed from service in order to minimize or remove the shifting and balancing reactions of the power system.

We modeled the system shown in Fig. 15 using a Real Time Digital Simulator (RTDS) to analyze the effect of line removal from service on the overall power system with and without a RECIPE process. Table 1 shows an events time line for removing transmission line 1 using traditional methods, without RECIPE technology.

Fig. 16 shows the transmission bus and distribution bus responses over a 40-second window for removing transmission line 1 using traditional methods. From the plots in Fig. 16, we can infer that the traditional way of removing transmission line 1 causes unwanted wear and tear in the distribution system and also affects the overall power quality of the system.

TABLE I  
TRANSMISSION LINE REMOVAL TIME LINE USING TRADITIONAL METHOD

| Time (s) | Event  |
|----------|--|
| t = 0    | Operator selects breakers for Line 1 open and sends the SCADA command to trip the breakers.  |
| t = 1.0  | SCADA master sends the trip command and breaker trips.   |
| t = 1.1  | Voltages on the transmission bus and distribution bus decrease; the tap changer associated with the distribution transformer independently increments the tap to accommodate for the lower voltages.           |
| t = 15.0 | Operator identifies the low voltage on the transmission bus and sends a command to switch on the capacitor bank.   |
| t = 16.0 | Capacitor bank switches on, providing the reactive power support, thereby raising the transmission bus voltage to nominal.   |
| t = 16.1 | The additional reactive power causes the distribution bus voltage to go above nominal; the tap changer again reacts by decrementing the tap position to bring back the distribution system voltage to nominal. |
| t = 31.0 | Distribution voltage returns to nominal, and the system is balanced.   |

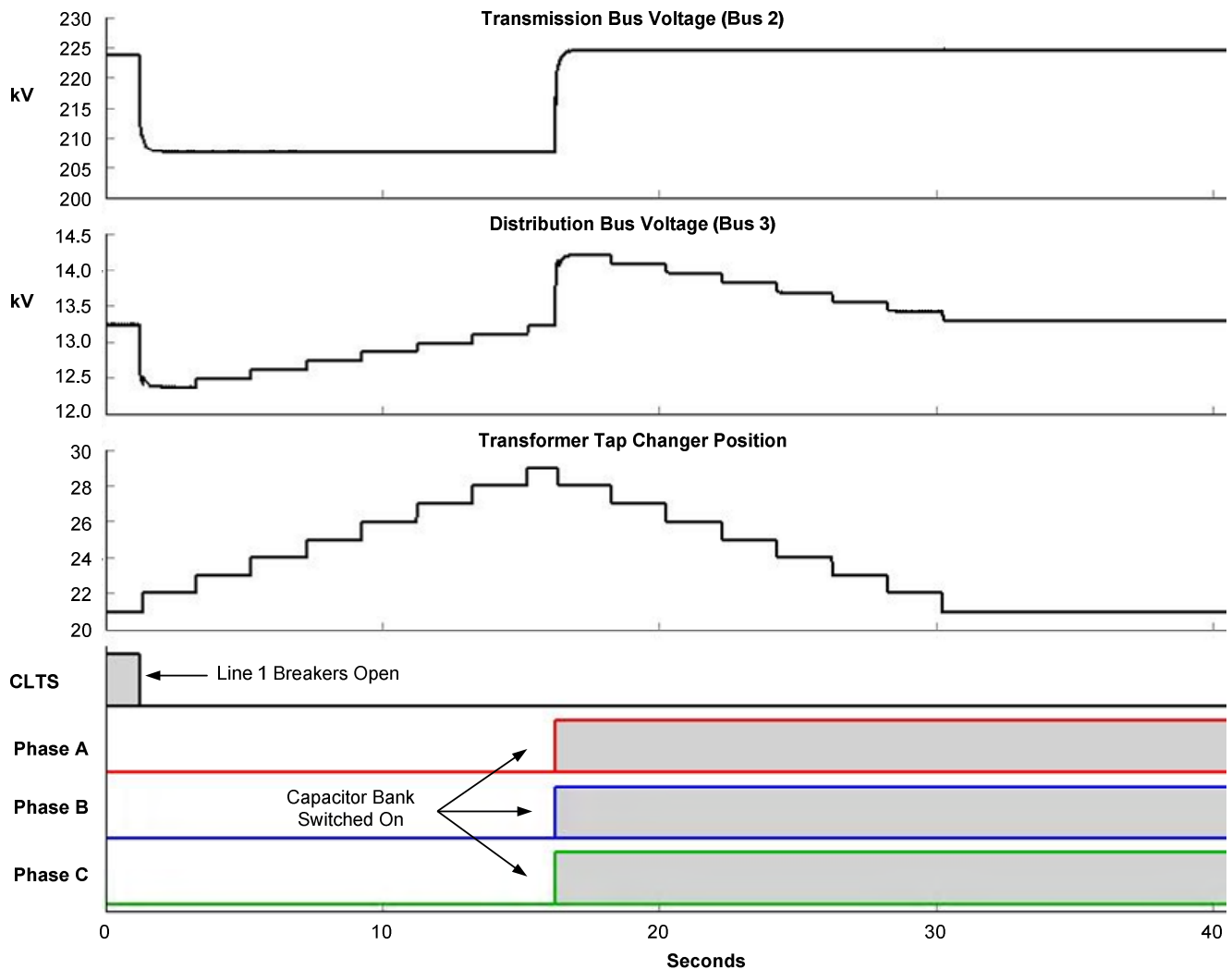

Fig. 16. RTDS Event Capture Showing Bus 2 RMS Voltage, Bus 3 RMS Voltage, Transformer Tap Changer Position, Line 1 Breaker Status, and the Capacitor Bank Breaker Status Without RECIPE Technology



We used the same power system simulation to analyze the effect of removing transmission line 1 using RECIPE technology. Table II shows the events time line for this simulation.

TABLE II  
TRANSMISSION LINE REMOVAL TIME LINE USING RECIPE METHOD

| Time (s) | Event   |
|----------|---|
| t = 0    | Operator selects the RECIPE to execute (RECIPE for line open and capacitor bank switch on).   |
| t = 0.5  | Automation controller confirms that the RECIPE is selected and the IED is ready to run.   |
| t = 0.7  | Operator arms the controller.   |
| t = 0.9  | IEDs execute the sub-RECIPE.  |
| t = 1.0  | Line 1 opens and capacitor bank is switched on. Voltages on the transmission bus and distribution bus do not experience any change in magnitudes, resulting in no tap changer action. |

Fig. 17 shows the transmission bus and distribution bus responses over a 40-second window using RECIPE technology. This clearly shows that with proper predicted actions, unnecessary disturbances and unwanted variations are avoided.

This simulation illustrates two advantages to using RECIPE technology. First, wear and tear on the power system is drastically reduced. Second, consistent power quality is maintained.

Another advantage to using RECIPE technology is improved power system security. Using RECIPE technology, local processing at the substation can be used to question a RECIPE that calls for vital actions such as circuit-breaker tripping, reactive power switching, etc. RECIPIES received at the substation are carefully examined by local logic and also sent to an independent security master or supervisor depending on the system operating conditions. For example, local logic can use contingency analysis results to make sure that opening circuit breakers will not result in voltage drop or voltage collapse. If needed, local logic can alarm the operator to prevent the opening of circuit breakers. Also, RECIPE technology rejects RECIPIES that do not include proper authentication or prior approved status, thus making them secure.

With the wide-spread deployment of IEDs capable of not only processing time-synchronized data but also taking precise control actions based on time, new methods for power system operation and control will emerge. The RECIPE method described above is only one example of how power system operation can be enhanced. RECIPE technology will be a vital part of future power system control, making power systems more efficient, secure, and reliable.

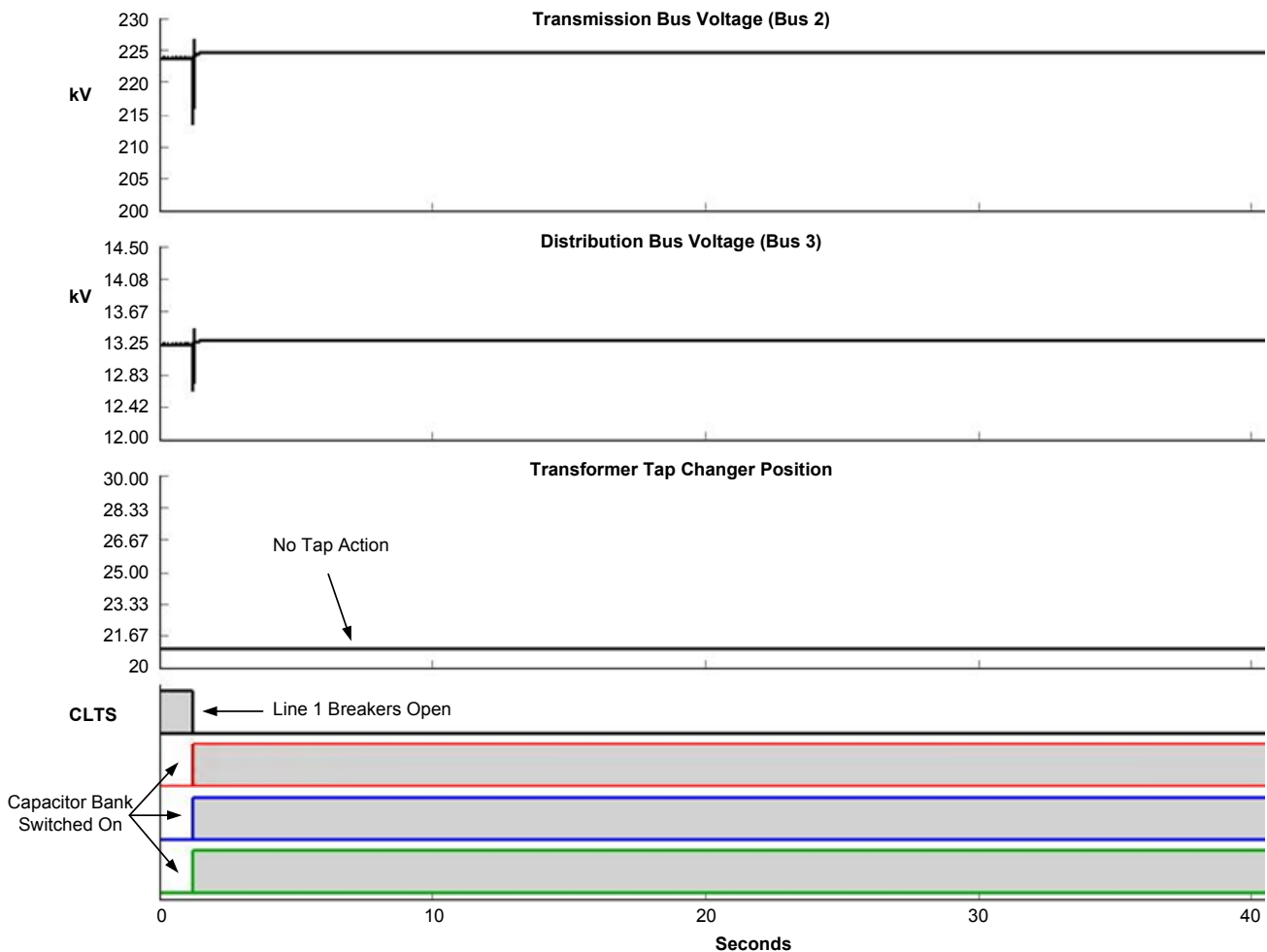

Fig. 17. RTDS Event Capture Showing Bus 2 RMS Voltage, Bus 3 RMS Voltage, Transformer Tap Changer Position, Line 1 Breaker Status, and the Capacitor Bank Breaker Status With RECIPE Technology

## V. CONCLUSIONS

Synchrophasors solve the problem of time incoherency required for wide-area power system control. With the ability to use time-synchronized measured values from across power systems, new protection and control schemes like those described in this paper are being implemented today.

- Synchrophasors provide a way to predict the impending voltage instability and provide high-speed control for mitigation.
- Synchrophasors are being used for high-speed distributed generation islanding.
- Synchrophasors overcome the limitations of traditional islanding detection methods using wide-area schemes such as angle difference and slip-acceleration methods.
- Synchrophasors provide the means to monitor and measure intermittent generation sources and control stability impacts on the overall power system.

We have also introduced time-synchronized RECIPE technology for power system automation and control. Synchrophasors identify, measure, and improve the overall power system efficiency through time-synchronized wide-area control.

## VI. REFERENCES

- [1] R. Sergel, NERC Press Release, Florida Outage, Feb. 26, 2008, Platts.com, "NERC Chief Applauds Florida System Restoration Efforts," Feb. 2008. Available: <http://www.renewablepowersummit.platts.com/Electric%20Power/Resources/News%20Features/fpl/index.xml>.
- [2] E. O. Schweitzer, III and D. E. Whitehead, "Real-World Synchrophasor Solutions," proceedings of the 35th Annual Western Protective Relay Conference, October 2008.
- [3] E. O. Schweitzer, III and D. E. Whitehead, "Real-Time Power System Control Using Synchrophasors," proceedings of the 34th Annual Western Protective Relay Conference, October 2007.
- [4] M. Donolo, M. Venkatasubramanian, A. Guzman, F. de Villiers, "Monitoring and Mitigating the Voltage Collapse Problem in the Natal Network," proceedings of the IEEE PES Conference and Exposition, Seattle, WA, March 2009.
- [5] *IEEE Standard for Interconnecting Distributed Resources With Electric Power Systems*, IEEE Standard 1547-2003, June 2003.
- [6] J. Mulhausen, J. Schaefer, M. Mynam, A. Guzman, M. Donolo, "Anti-Islanding Today, Successful Islanding in the Future," proceedings of the 36th Annual Western Protective Relay Conference, October 2009.
- [7] R. Moxley and M. Wronski, "Using Time Error Differential Measurement in Protection Applications," proceedings of the 33rd Annual Western Protective Relay Conference, October 2006.
- [8] "Texas Synchrophasor Network," by University of Texas at Austin. Available at: [http://users.ece.utexas.edu/~grady/Texas\\_Synchrophasor\\_Network.html](http://users.ece.utexas.edu/~grady/Texas_Synchrophasor_Network.html).

## VII. BIOGRAPHIES

**Dr. Edmund O. Schweitzer, III** is recognized as a pioneer in digital protection and holds the grade of Fellow of the IEEE, a title bestowed on less than one percent of IEEE members. In 2002, he was elected a member of the National Academy of Engineering. He is the recipient of the Graduate Alumni Achievement Award from Washington State University and the Purdue University Outstanding Electrical and Computer Engineer Award. In September 2005, he was awarded an honorary doctorate from Universidad Autónoma de Nuevo León in Monterrey, Mexico, for his contribution to the development of electric power systems worldwide. He has written dozens of technical papers in the areas of digital relay design and reliability and holds more than 30 patents pertaining to electric power system protection, metering, monitoring, and control. Dr. Schweitzer received his Bachelor's and Master's degrees in electrical engineering from Purdue University, and his PhD from Washington

State University. He served on the electrical engineering faculties of Ohio University and Washington State University, and in 1982, he founded Schweitzer Engineering Laboratories, Inc. to develop and manufacture digital protective relays and related products and services. Today, SEL is an employee-owned company, which serves the electric power industry worldwide, and is certified to the international quality standard ISO-9001. SEL equipment is in service at voltages from 5 kV through 500 kV, to protect feeders, motors, transformers, capacitor banks, transmission lines, and other power apparatus.

**David Whitehead, P.E.** is the vice president of Research and Development at Schweitzer Engineering Laboratories, Inc. Prior to joining SEL, he worked for General Dynamics, Electric Boat Division as a combat systems engineer. He received his BSEE from Washington State University in 1989, his MSEE from Rensselaer Polytechnic Institute in 1994, and is pursuing his PhD at the University of Idaho. He is a registered professional engineer in Washington and Maryland and a Senior Member of the IEEE. Mr. Whitehead holds seven patents with several others pending. He has worked at SEL since 1994 as a hardware engineer, research engineer, and chief engineer/assistant director, and has been responsible for the design of advanced hardware, embedded firmware, and PC software.

**Greg Zweigle** received his Master's of Science in Electrical Engineering and Master's of Science in Chemistry degrees from Washington State University. Also, he received a Bachelor's of Science Physics degree from Northwest Nazarene University. He is presently a research and engineering manager at Schweitzer Engineering Laboratories, Inc. Previously he worked as a principle research engineer in the Research group and as a senior software developer at SEL. He has been responsible for PMU signal processing algorithms, embedded system architectures, and synchrophasor-based power system solution designs. Mr. Zweigle holds seven patents and is presently pursuing a PhD focusing on energy systems. He is a member of the IEEE and the ACS.

**Krishnanjan Gubba Ravikumar** received his Master's degree in Electrical Engineering from Mississippi State University in 2009 and his Bachelor's degree in Electrical and Electronics Engineering from Anna University, India in 2007. He focused his Master's on power engineering working as a research assistant in the PERL (Power & Energy Research Lab) of Mississippi State University. He was the recipient of the Mississippi State Research Assistant of the Year Award for 2009. He is presently working as an associate power engineer at Schweitzer Engineering Laboratories, Inc. where he focuses on development and operations of synchrophasor power systems. His research areas of interest include real-time power system modeling and simulation, substation automation, synchrophasors and their applications, power system stability, and SCADA systems. He is a member of the IEEE and Eta Kappa Nu Honor Society.