SUBSTATION RELAY DATA AND COMMUNICATION

**KENNETH C. BEHRENDT
SCHWEITZER ENGINEERING LABORATORIES, INC.
PULLMAN, WASHINGTON**

**MICHAEL J. DOOD
WISCONSIN ELECTRIC POWER COMPANY
MILWAUKEE, WISCONSIN**

Presented before the

**22nd ANNUAL
WESTERN PROTECTIVE RELAY CONFERENCE
SPOKANE, WASHINGTON
OCTOBER 24 - 26, 1995**

SUBSTATION RELAY DATA AND COMMUNICATION

Kenneth C. Behrendt
Schweitzer Engineering Laboratories, Inc.
Pullman, Washington USA

Michael J. Dood
Wisconsin Electric Power Company
Milwaukee, Wisconsin USA

ABSTRACT

Many of today's electric utility substations include digital relays and other intelligent electronic devices (IEDs) that record and store a variety of data about their control interface, internal operation and performance, and about the power system they monitor, control, and protect. These data have short- and long-term value for operating, maintenance, planning, engineering, and customer service personnel. Many utilities are designing and retrofitting substations with communication schemes to integrate data from various microprocessor-based devices and capitalize on the protection, control, metering, fault recording, and communication functions available in digital devices. By doing so, many utilities have shown that a significant reduction can be made in substation capital and operation and maintenance costs.

This paper discusses the importance of digital relay data, the evolution in communication interface development to meet user information needs, and some practical applications for integrated substation relay data using various communication media.

INTRODUCTION

Multifunction digital relays have been available for over ten years and in popular use for nearly that long. Today, digital relays are by far the most popular choice for new protection and control installations, and they are widely applied to replace aging electromechanical and solid-state electronic component-type relays and relay systems.

There are many reasons for the digital relay's popularity: price, reliability, functionality, and flexibility. But the feature that separates the digital relay from previous devices is information. Digital relays offer real-time and historical information about themselves, the power system, the protection and control system, and selected substation equipment. Such information includes:

- Fault location and fault type
- Prefault, fault, and post-fault currents and voltages
- Relay internal element status
- Relay control input and output status
- Instantaneous and demand metering
- Breaker operation data
- Relay self-test status

Traditional substation designs used separate devices to provide some of this information, such as metering and fault data. Other information, such as breaker operation data and relay self-test status, is not available in traditional substation installations.

Multifunction digital relays have opened a whole new world of information never before available and at virtually no additional cost -- in fact, at a reduced cost in many cases. Because of the widespread value of the relay's data, a variety of utility personnel, representing the interests of operating, maintenance, planning, engineering, and customer service, request the information they need in a format convenient for them to work with and in a time frame related to the response requirements of their job responsibilities. Accommodating these needs presents a challenge to the substation design team responsible for balancing functional and informational requirements of the substation design. Communication architecture and interface techniques play an important part in this process. But, the most important ingredient in the process is the imagination of the utility personnel who strive to minimize cost, increase efficiency, and improve power-system operation and reliability using the newfound tools available in today's integrated substations.

THE DIGITAL RELAY COMMUNICATION INTERFACE - AN EVOLUTION

The digital relay communication interface has evolved over time to meet changing user needs. User needs have changed as utility personnel recognize the value of data provided by the digital relay and as new technology provided additional communication options.

Local Target Display

The mechanical flag or target was the first interface developed to communicate that the electro-mechanical relay had performed a function. As relays became more sophisticated, targeting systems evolved as well, to indicate which phase or zone of a particular relay's operating system had functioned. Solid-state relays carried on this tradition through the use of electronic flags and light emitting diodes (LEDs). Some solid-state relay systems included LEDs to indicate the status of basic internal logic systems. It is not surprising that early digital relays incorporated LEDs to indicate, in basic function, what the relay had done. The conventional process of manual relay target collection, recording, resetting, and transcription is well established, so targets remain as a consistent part of even the newest relay designs. However, as communication and information processing techniques progress, the value of local relay targets will diminish and possibly disappear.

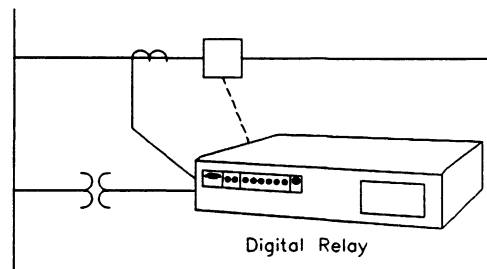

Figure 1: Digital Relay with Target Interface

Local Display for Digital Data

As digital relay data became more sophisticated, the need arose to provide a more sophisticated medium to communicate this information. Fault information, such as current level, fault type, and fault location, required a local alphanumeric display for local interrogation by personnel dispatched to collect relay targets. Since faults occur rather infrequently, the local display was put to more continuous use to display real-time information, such as present voltage and current quantities.

This, in essence, integrated the meter function into the relay. Many other functions followed, including relay element status, fault history, relay settings, line data, relay self-test status, and breaker operation data. With the addition of push-buttons, the display also provides the ability to enter and change relay settings on some relays.

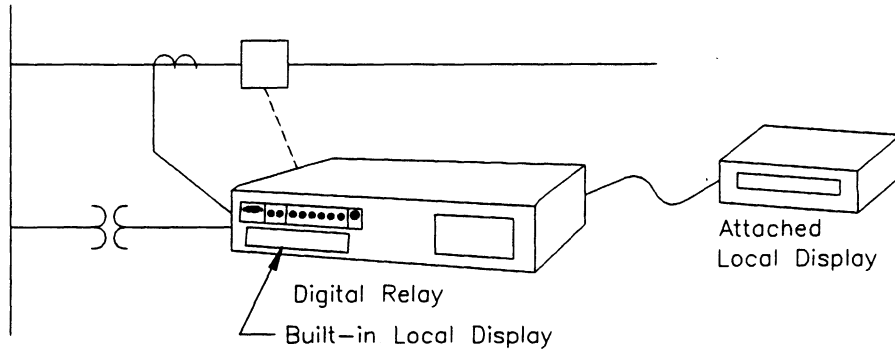

Figure 2: Digital Relay with Target Interface and Built-In or Attached Local Display

Communicate Locally with Terminal or PC

As digital relays progressed in both capability and information, the local targets and display capabilities quickly became inadequate. One or more communication ports became standard on digital relays to permit connection with a terminal or a PC with terminal emulation software. This greatly expanded the digital relay communication interface capability. Virtually all information in the digital relay could be accessed, and relay settings and other functions could be easily entered and changed.

Fortunately, the computer industry had developed some basic hardware interface standards for interconnecting computer equipment. One standard, EIA-232, became the initial defining communication interface that remains today, an almost universal constant among PCs, digital relays, and other IEDs.

Portable terminal and PC technology, and communication software capability, have developed along with the digital relay technology to meet a number of new requirements.

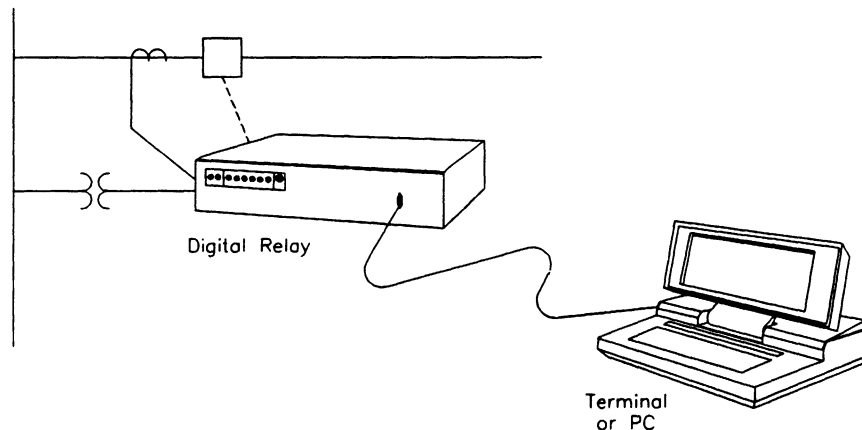

Figure 3: Digital Relay with Local Terminal or PC for Local Communication

Interrogate Relay to Display and Capture Data/Reports

Communication and other support programs developed to permit easy interrogation of relays to display real-time and historical relay information and capture information to files for later analysis and reporting.

Enter Relay Settings

Proper relay settings, critical to the primary protection and control function of all types of relays, are most easily entered in the digital relay through a serial EIA-232 PC-to-relay communication interface. This interface also permits the user to confirm relay settings and capture relay setting information to a PC file for documentation and record-keeping purposes. Techniques have developed to create, store, and modify relay setting files on the PC that are downloaded to the relay, easing the process of entering relay settings. Access to setting functions is typically restricted by passwords or passcodes to provide relay setting security.

Control Breaker

Some digital relays have control command functions that permit the user to open and close the power-system breaker through the existing control wiring between relay and breaker. This permits simple functional testing of the relay's output contacts and breaker control wiring. Access to breaker-control functions is typically restricted by security passwords or passcodes.

Print Relay Messages

Some digital relays include a communication port that can be connected to a printer. Relay messages about faults, relay self-test status, and relay group setting changes are automatically sent to the printer to provide local documentation for operating and testing personnel.

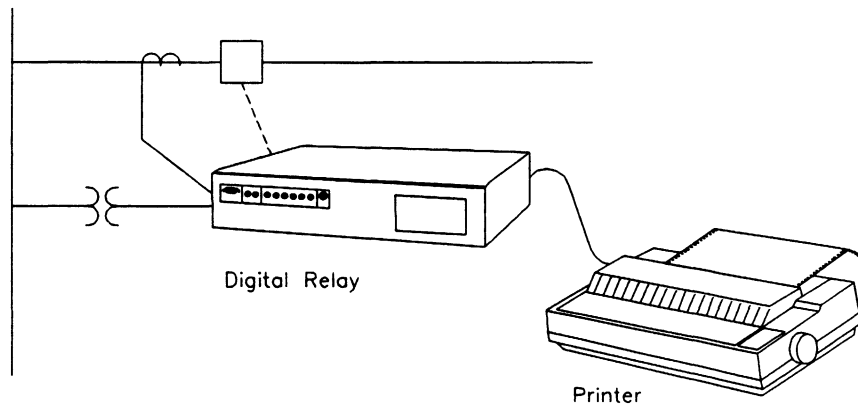

Figure 4: Digital Relay with Attached Printer

Communicate Remotely with PC and Modem (Basic SCADA)

Digital relay interrogation and control functions that are performed locally can also be performed from remote locations with the use of PC, modems, and communication software. Communication media includes dial-up phone circuits, leased phone circuits, and user-owned microwave and/or fiber-optic communication networks. This remote communication capability allows engineering,

operating, testing, maintenance, and planning personnel to directly access real-time and historical relay information that they need to perform their jobs.

Basic SCADA functions are performed by some utilities using these remote interrogation and control capabilities. Access to various setting and control functions is typically restricted by passwords or passcodes, similar to local communication access security.

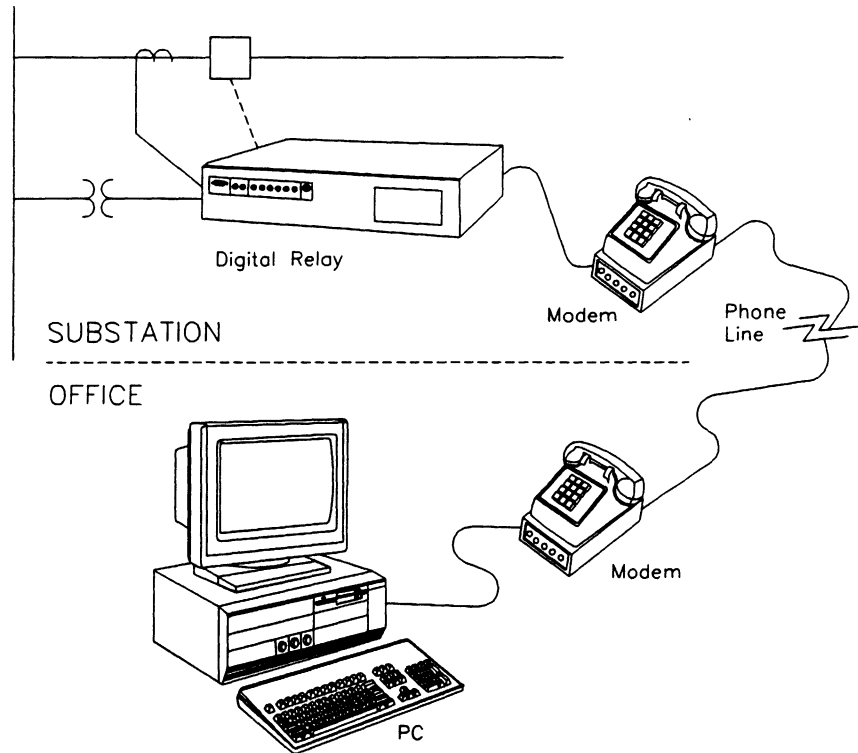

Figure 5: Digital Relay with Dial-Up Modem for Remote Data Communication

Multiple Relay Communication

The proliferation of digital relays and IEDs with local and remote communication capability requires communication concentrators that allow communication with multiple devices through a single communication channel. Two communication configurations, multidrop and point-to-point, are typically used in today's substations to interface with multiple relays and other IEDs. There are advantages and disadvantages to each of these configurations. For the purpose of this paper, the point-to-point configuration will be shown. Point-to-point communication typically uses the almost universal EIA-232 interface standard found on computer equipment and almost all digital relays and other IEDs. A port switch device is commonly used to transfer the communication connection from one IED to another.

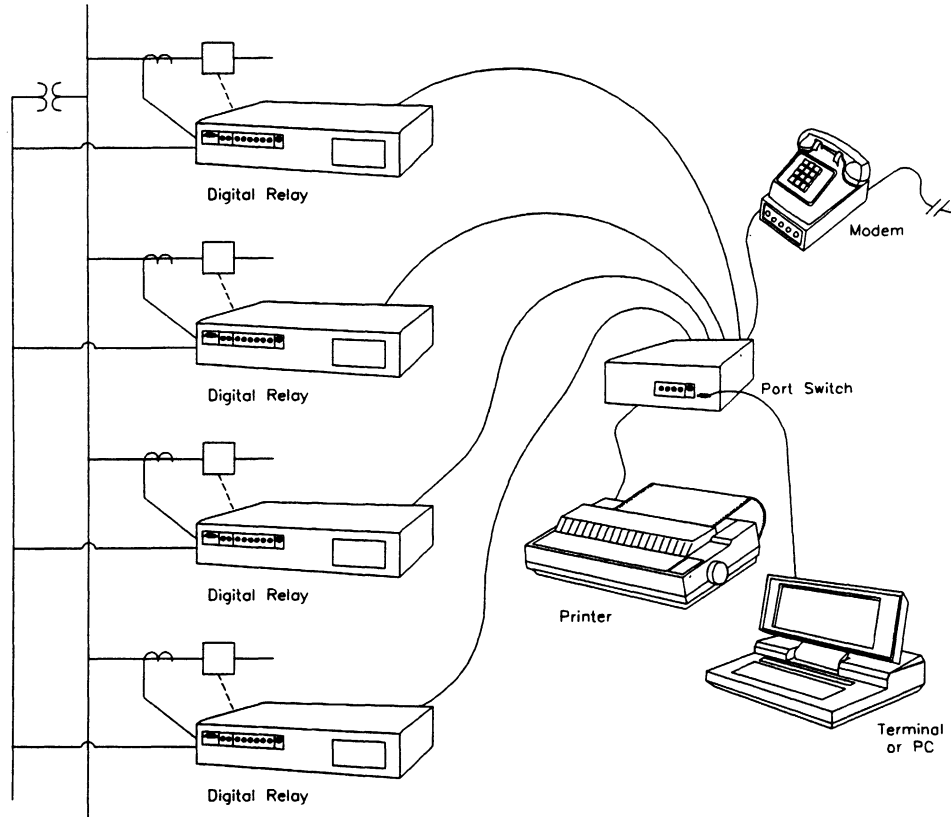

Figure 6: Multiple Digital Relays with Port Switch for Local and Remote Communication

Basic port switches allow communication between a master port and only one slave port at a time. This permits either local or remote communication with a single relay or IED. Some basic port switches buffer messages automatically sent from attached relays. The port switch may also include a printer port to print these messages for the convenience of a local operator.

Time Sync Multiple Relays to Each Other and System Clock

Digital relays and many other IEDs include a built-in clock to time-tag sampled data and events. This time-tagged information adds significant value to each individual device. However, all micro-processor based clocks, whether battery-backed or not, have some drift. Over time, differences develop between the time on each device that cause considerable confusion when comparing sampled data and event information from multiple devices.

The use of multiple digital relays and IEDs with built-in clocks requires a system to synchronize these clocks, either continuously or periodically. Continuous synchronization can be accomplished several ways, but the use of IRIG-B time-code synchronization is quite popular. The demodulated IRIG-B time code consists of a logic level (0 to +5 volts) pulse train encoded to provide day-of-year and time-of-day. Many digital relays and IEDs include a port designed to accept either a 1 kHz modulated or a demodulated IRIG-B signal.

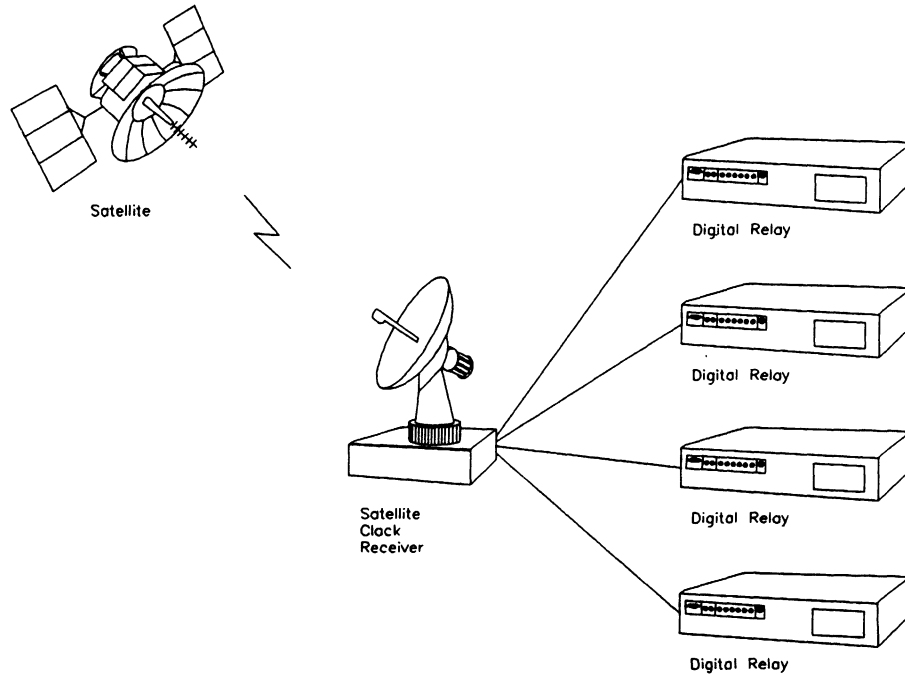

Figure 7: Multiple Digital Relays with Synchronizing IRIG-B Time-Code Input

Some devices that do not accept a synchronizing time-code input will accept a date and time command to update and correct their built-in clock/calendar. While not as accurate as a time-code input, the date and time command method, performed periodically, maintains date and time synchronization that satisfies most application requirements.

SCADA/RTU Interface

Real-time digital relay data is of particular value for system operating personnel. Real-time voltage, current, watt, and VAR data are needed to operate a system. Fault type and fault location, unavailable until the advent of fault locating digital relays, are now required by most operating and dispatch centers to guide system restoration. Economics and efficiency dictate that this information be transmitted to operating personnel through the same SCADA system interface from which they receive all other operating data.

Conventional SCADA RTUs accept only analog inputs (scaled current or voltage) and status inputs (dry or voltage wetted contacts). Digital relay data, therefore, are not directly compatible with these conventional RTUs. Although it seems somewhat inefficient to convert the digital relay data, which are originally analog and contact status, back to analog and contact status output to satisfy system operating personnel, in many cases, conversion is more cost effective than wiring separate devices to provide the same output.

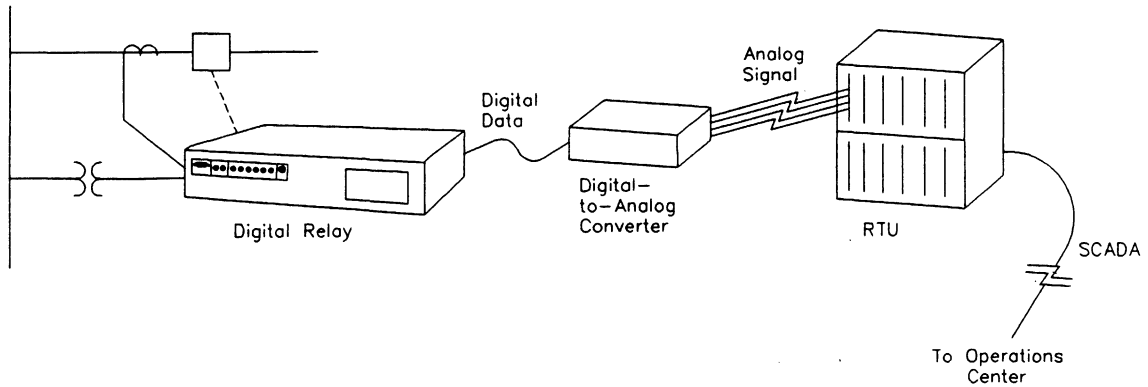

Figure 8: Interface Between Digital Relay and Analog RTU

Modern RTUs operate on digital principles that allow direct acquisition of digital data, permitting a direct interface between the RTU and digital relays or other IEDs. The same type of interface can be established with Programmable Logic Controllers (PLCs). Although communication protocol issues can complicate the use of this interface, many RTU and PLC vendors have developed simple and effective methods to establish this communication interface. Once in the RTU or PLC, these data are polled from the SCADA central processor or passed to other IEDs like any other digital data.

Maintaining the digital relay data in digital format has the obvious advantage of security, maintained accuracy, and data handling efficiencies that produce better results at a lower cost. Other advantages accrue because more data are available from the digital relay than basic meter and fault data, including relay targets, relay elements, breaker interruption data, event history, relay self-test status, and settings.

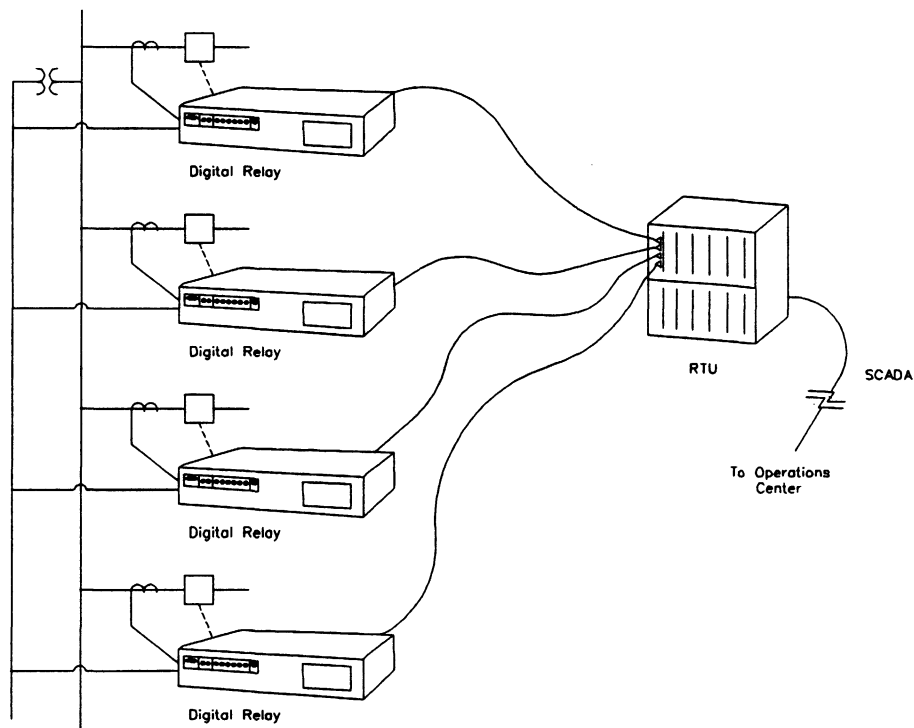

Figure 9: Communication Interface Between Digital Relays and Multipoint Digital RTU

Electromechanical Interface

Although it may not be considered on the same level as ASCII and binary digital relay communication, the digital relay electromechanical interface cannot be disregarded. This interface links the digital relay with the conventional inputs and outputs of the solid-state and electromechanical world. The status of these inputs and outputs is essential to a more complete understanding of operating states and sequence of events. In the solid-state and electromechanical world, the state of these interface points must be monitored by separate, external devices such as sequence of events recorders and oscillographs or fault recorders with status input points.

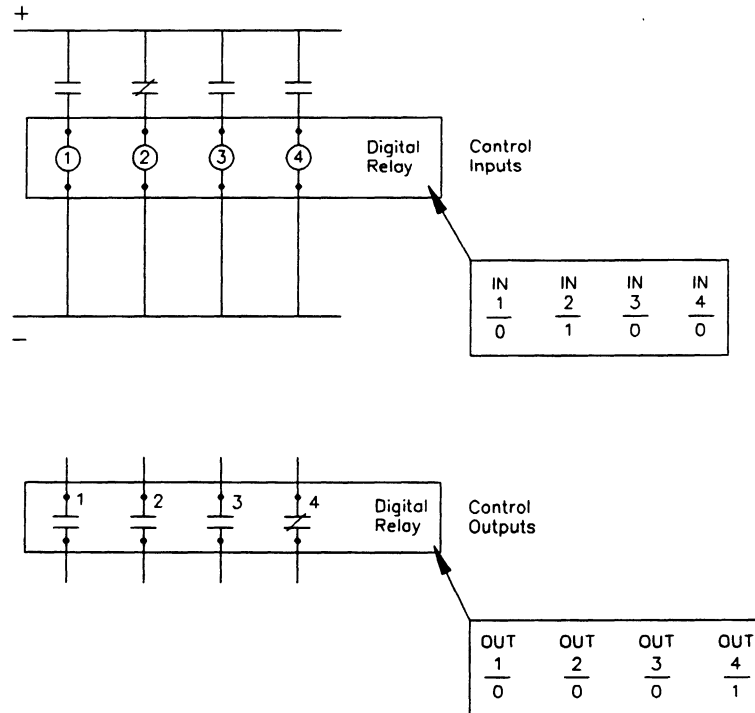

Figure 10: Digital Relay Electromechanical Interface

Most digital relays maintain the status of these points internally in a binary word format where the status of the input, off or on, and the status of the output, open or closed, is easily related to a binary state of 0 or 1. These binary words are updated and maintained in the digital relay and are available to interrogate or transmit through the communication interface.

INTEGRATED DIGITAL RELAY DATA APPLICATIONS

Many utilities are examining their traditional practices in light of industry competition and renewed customer focus. As a result, utilities are focusing on ways to reduce both capital and operation and maintenance expenditures as well as ways to enhance revenue, while retaining or improving customer service reliability. One contribution toward these goals is the use of substation integration techniques.

Substation integration challenges traditional methods and opens the door to new and more effective methods of transforming, distributing, and controlling electric power. To a large extent, this new frontier exists because of the successful development and use of digital protective relays.

The key element in the digital relay is information. The key to successful substation integration is communicating and processing that information in the most efficient and economical method possible. This requires “open” network concepts that provide versatile options to satisfy multiple user needs.

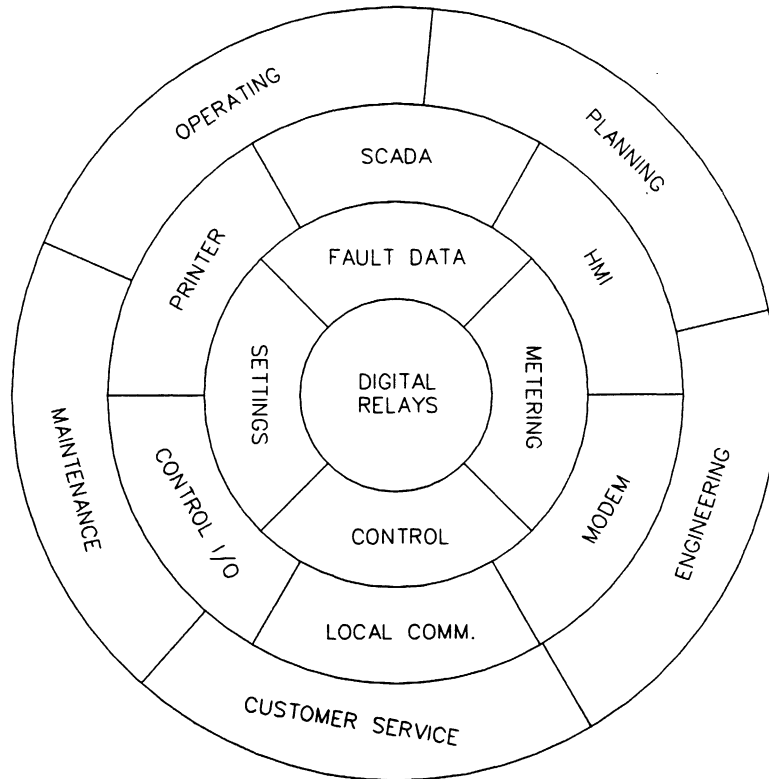

Figure 11: Integrated Substation Digital Relay Data and Communication

Accommodating Traditional Needs

Digital relays have evolved to include multiple interfaces, each designed to meet specific traditional data and control requirements. Integrated substation design offers the opportunity to meet these needs through a single digital interface, as shown in Table 1.

Table 1: Summary of Traditional Relay Data and Control Communication

Function ⇒ Interface ↓	Real-Time Data	Historical Data	Local Control	Remote Control	Relay Set	Time Set/Sync.
Target Display		✓				
Relay HMI	✓	✓	✓		✓	✓
Printer Port		✓				
Local PC Port	✓	✓	✓		✓	✓
Modem Port	✓	✓		✓	✓	✓
Clock Port						✓
SCADA Interface	✓			✓		
Integrated SS Function	✓	✓	✓	✓	✓	✓

While integrated substation design accommodates and serves many traditional utility purposes, utility personnel use substation integration to go beyond traditional applications to achieve further cost efficiencies and system improvements.

New Ways to Use Substation Relay Data and Communication

The demand for digital relay data seems insatiable. The reason for this stems from the innovative and creative applications of these data that digital relay users devise to solve long-standing problems that previously had no practical or economic solution. These new application techniques offer opportunities to improve protection, enhance control, speed outage restoration, improve operations analysis, automate maintenance functions, and improve planning and design data.

The following applications demonstrate improvements made feasible with substation digital relay data and communication.

Improve Protection

Use Digital Clock/Calendar to Change Protection

Some utilities have found that sensitive protection or fuse-saving coordination techniques result in nuisance outages that adversely affect reliability to critical customers. The ability to change protection based on time-of-day and day-of-week provides a compromise solution that avoids or reduces nuisance operations during hours when these critical customers are in operation. This also provides more sensitive protection and special coordination requirements when they are not in operation. This is easily accomplished with digital relays by changing settings and logic through remote or local communication based on time-of-day and day-of-week.

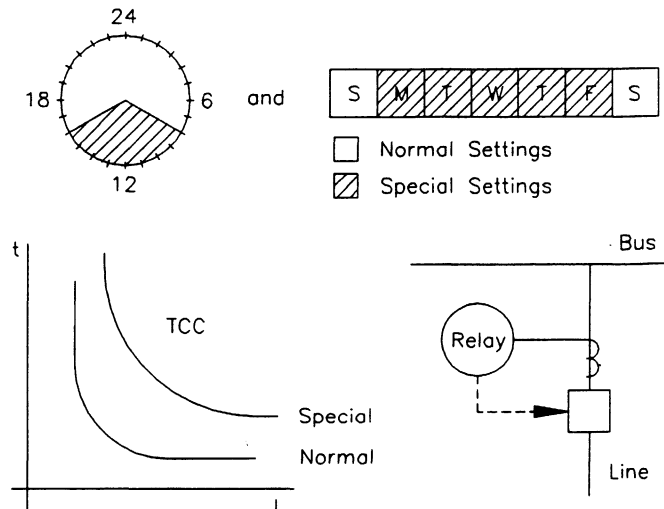

Figure 12: Change Protection Based on Time-of-Day and Day-of-Week

Use Digital Relay Elements and Inputs to Change Protection

Protection requirements can change with system load and configuration. Conventional protection schemes must accommodate the worst-case operating scenario, compromising sensitivity and/or coordination under normal conditions. Optimize digital relay system protection based on the status of control inputs and internal relay elements.

- **Change Protection Based on Load and Breaker Status**

One example using this technique alters distribution protection by changing distribution relay settings on each digital feeder relay when phase current demand or neutral current demand exceed specified levels. The original settings are highly sensitive. The new setting has less sensitive phase and residual overcurrent settings that tolerate higher loading but have reduced, but adequate, sensitivity. Relay settings on all circuits are changed to a third level when any one of the distribution relays trip. The third level settings have a longer time delay to tolerate inrush and surges following the fault on any of the distribution circuits. The current inrush typically occurs on all circuits following a fault on one circuit because of short-term transformer magnetizing inrush and the longer-term effect of restarting air conditioner motors that stalled during the fault. When all conditions return to normal for a prescribed time, the digital relays change back to their original settings.

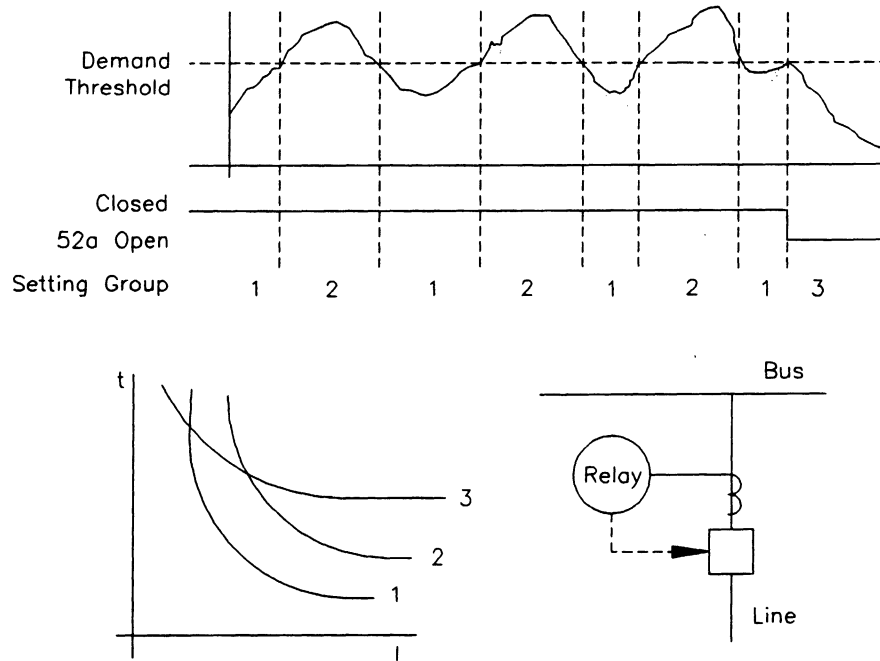

Figure 13: Change Protection Based on Load and Breaker Status

- **Increase Sensitivity of Backup Relaying**

Another example of this type of adaptive protection is shown in Figure 14. Here, the alarm contact from each of the digital feeder relays is connected to permit the backup relay to directly trip the breaker for the alarmed feeder. At the same time, the settings on the backup relay are changed to provide additional sensitivity to permit the backup relay to adequately protect the alarmed feeder.

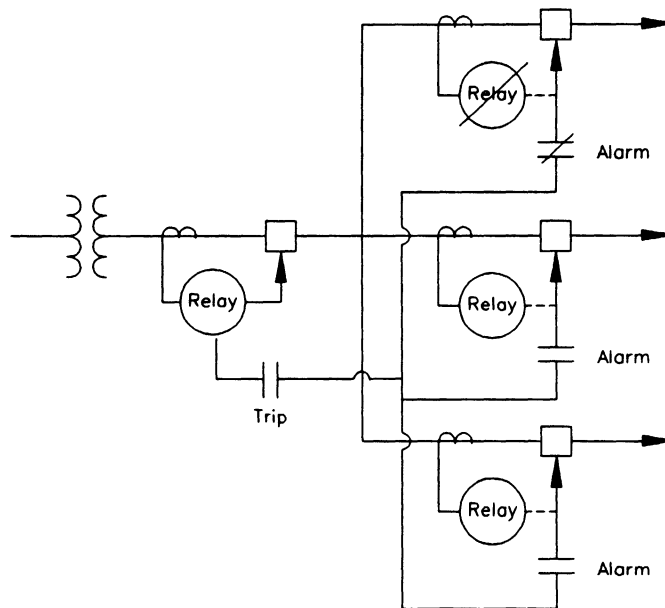

Figure 14: Improve Backup Relaying

- **Change Relay Settings Based on Source Conditions**

Protective relay settings may be adequate during normal source conditions, but alternate relay settings may be required under some contingency source conditions. In the example shown in Figure 15, the normal relay settings use negative-sequence polarizing for ground fault protection. However, when the generator on the far side of the delta-wye transformer is out of service, the negative-sequence source may become too weak to adequately polarize the relay, making zero-sequence current the preferred polarizing input. Automatically change relay settings from negative-sequence polarizing to zero-sequence current polarizing when the generator breaker opens, and change back to negative-sequence polarizing when the generator is in service.

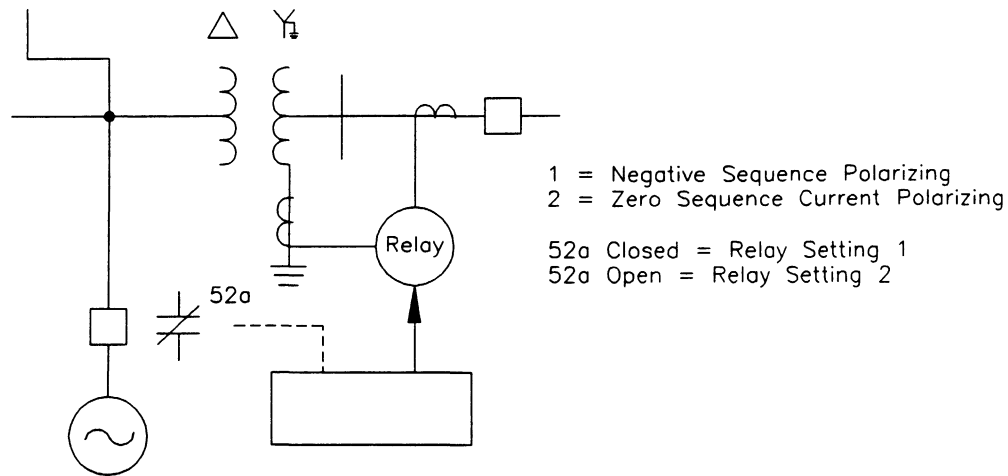

Figure 15: Change Relay Settings Based on Source Conditions

- **Change Remote Relay Settings Based on System Configuration**

Basic zone distance transmission line protection requires Zone 2 time-delayed overreaching relay elements. System configuration changes for equipment maintenance can reduce or even disable protection. As this example shows, use the dial-out and dial-in capability to automatically change the overreaching Zone 2 settings on each remote relay based on breaker and bypass switch status to restore adequate protection.

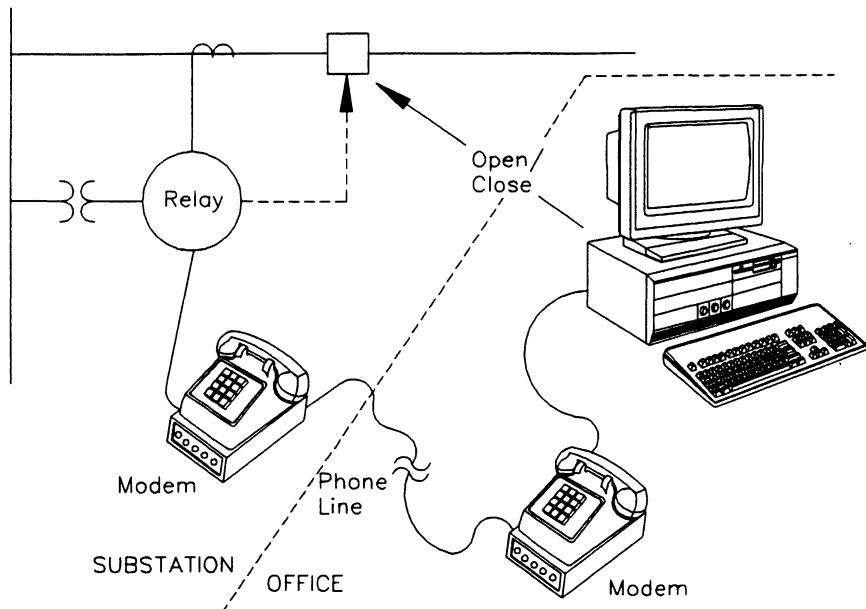

Figure 17: Control the Power-System Breaker Through Relay Commands

Remotely Control Auto Reclosing

A recloser on-off control switch is often included in line and feeder protection schemes to disable auto-reclosing when crews are working on or near energized line conductors. To operate this switch, someone must visit the station to turn auto-reclosing off and return again after the line work is completed to turn auto-reclosing back on. With multifunction digital relays, a control bit or multiple settings can be used to control auto-reclosing through remote communication, saving the cost to travel to the substation twice. As an added bonus, the relay element status indicates the auto-reclosing state, off or on, confirming the control change to the remote operator.

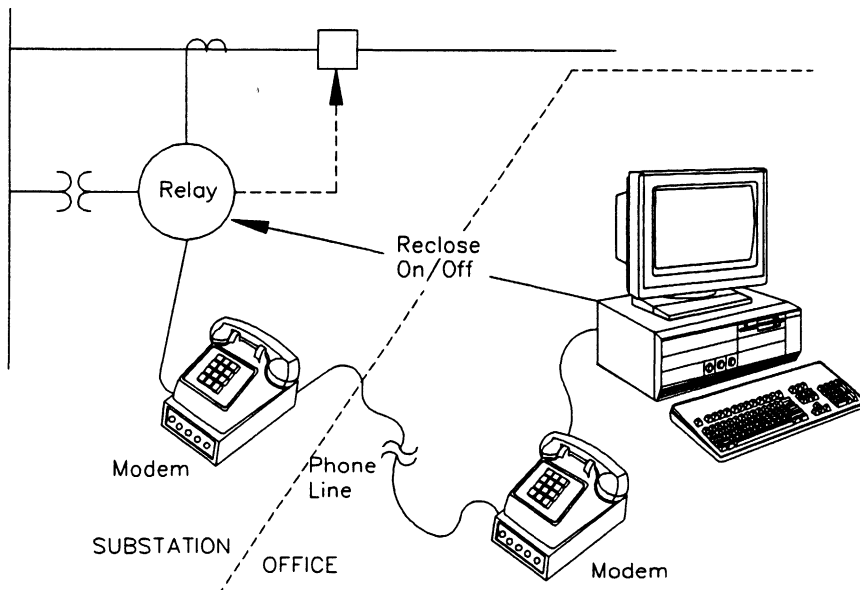

Figure 18: Remotely Control Auto-Reclosing

Some utilities use this communication capability to control reclosing on a wide-area basis. During good weather, when the risk of weather-related faults and outages is low, auto-reclosing is turned off to minimize the risk of reclosing for faults that may have human involvement, such as car accidents and crane contact. During storms, when the risk of weather-related faults and outages increases dramatically, auto-reclosing is enabled to optimize service reliability.

Speed Outage Restoration

The traditional method to find power-system faults usually involves two steps. First, the operator tries to energize the faulted circuit until he/she is convinced the fault is permanent. Most operators will “instinctively” make at least one attempt, even though the circuit may have already gone through one or more automatic reclose operations. Once it is determined that the fault is permanent, the second step is to sectionalize the circuit and try to energize only part of the circuit. Relay targets may be of some help to determine the nature of the fault, but it takes time to collect conventional relay targets because they must be read by an operator at the substation. The sectionalizing process will eventually reduce the fault location to an area or length of circuit between sectionalizing switches. If a customer has not reported the exact location because of the explosive results of the unsuccessful reclose attempts, personnel must be dispatched to patrol the circuit in the suspected fault location area. Needless to say, this approach is time consuming, labor intensive, and potentially hazardous.

Send Fault Type and Fault Location Through SCADA

Digital relays with built-in fault locating algorithms offer a tremendous opportunity to speed outage restoration. The fault location information is used to direct operating personnel to the proximity of the fault in a very timely manner, without the need for numerous reclose attempts. The communication capability of the digital relay offers several ways to retrieve the fault data from the relay in a timely fashion. The quickest method is to transmit the fault information through the SCADA system back to the control and dispatching center, as shown in Figure 19.

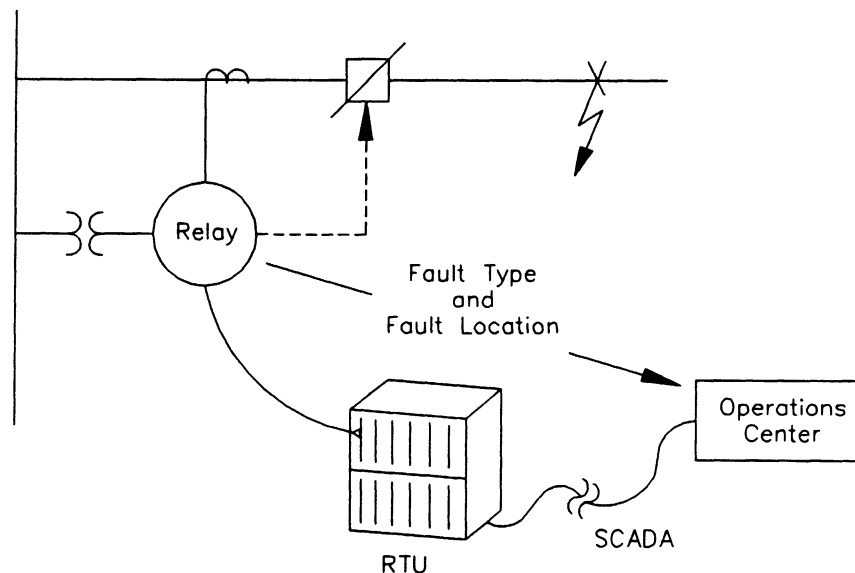

Figure 19: Send Fault Type and Fault Location Through SCADA

Automatically Call Key Utility Personnel

For systems that do not have SCADA, or where locations other than the operations center must be notified about faults and sent fault data, the automatic dial-out process presents some very nice solutions. With this communication capability, a variety of personnel at various locations can be sent notification and fault information, even paged, as shown in Figure 20.

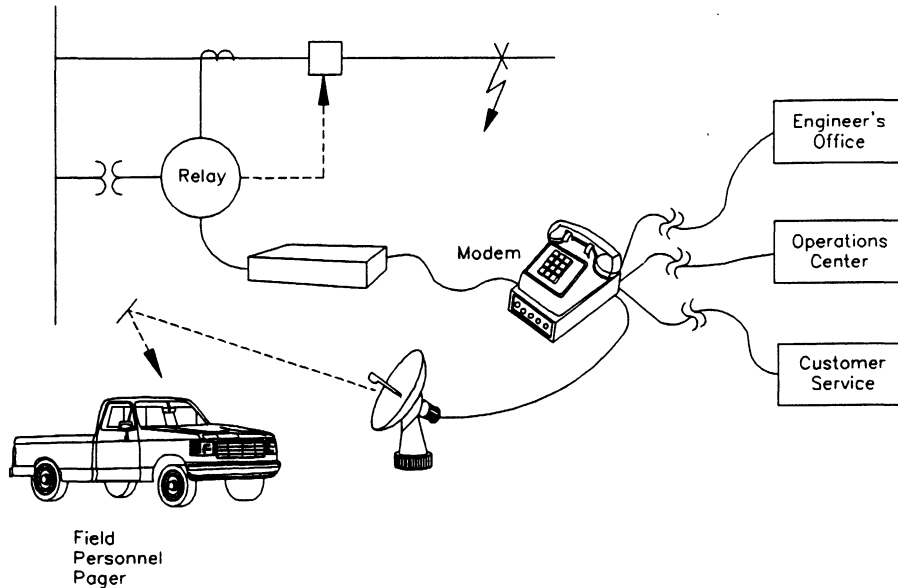

Figure 20: Communicate Fault Data to Speed Outage Restoration

Improve Operations Analysis Efficiency

Digital relays offer considerable information to perform operations analysis better than ever before possible with solid-state and electromechanical relays. The fault data and relay event reports show directly the protective relay's performance for each successive sample of power-system fault data. The power system's response to various faults at known locations is now also available to perform comparison with fault study models. With the proliferation of digital relays at numerous substation locations, the new challenge is how to manage the collection of this information in a timely manner. Data can be made available in printed format and in PC file format. The latter format offers the advantage of further interrogation and analysis through special software programs. The printed report can always be created from the file format at a later date, so the file format tends to be preferred by most utility personnel.

Event report file collection from individual relays can be time consuming. New substation integration techniques offer data concentration and automated data transfer capabilities.

Collect Complete Event Report Data on Demand

Use substation integration to concentrate the event reports from several digital relays at a single location to make data collection more efficient. This avoids the need to establish communication with each individual digital relay to collect event reports.

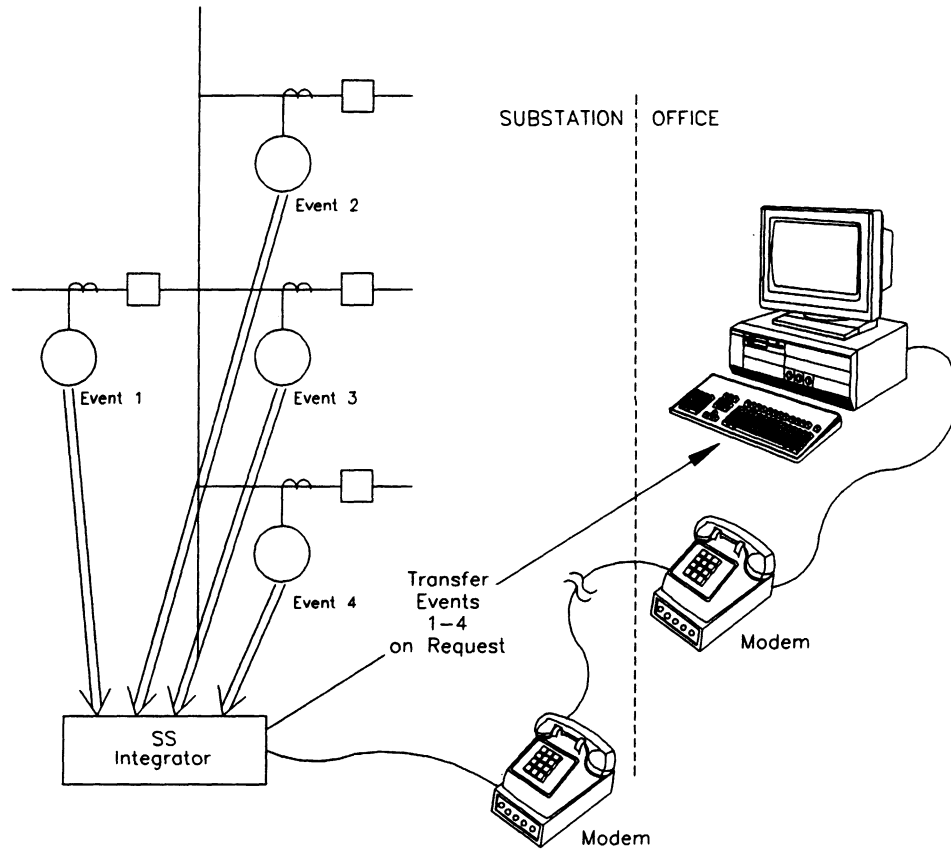

Figure 21: Collect Event Reports from a Single Location

Automatically Send Event Report Data at a Predetermined Time

Another useful capability is having the event report data from the weekend or previous night waiting for you when you arrive at the office in the morning. Use substation integration logic to send the event reports at a specific time each day, on selected days of the week.

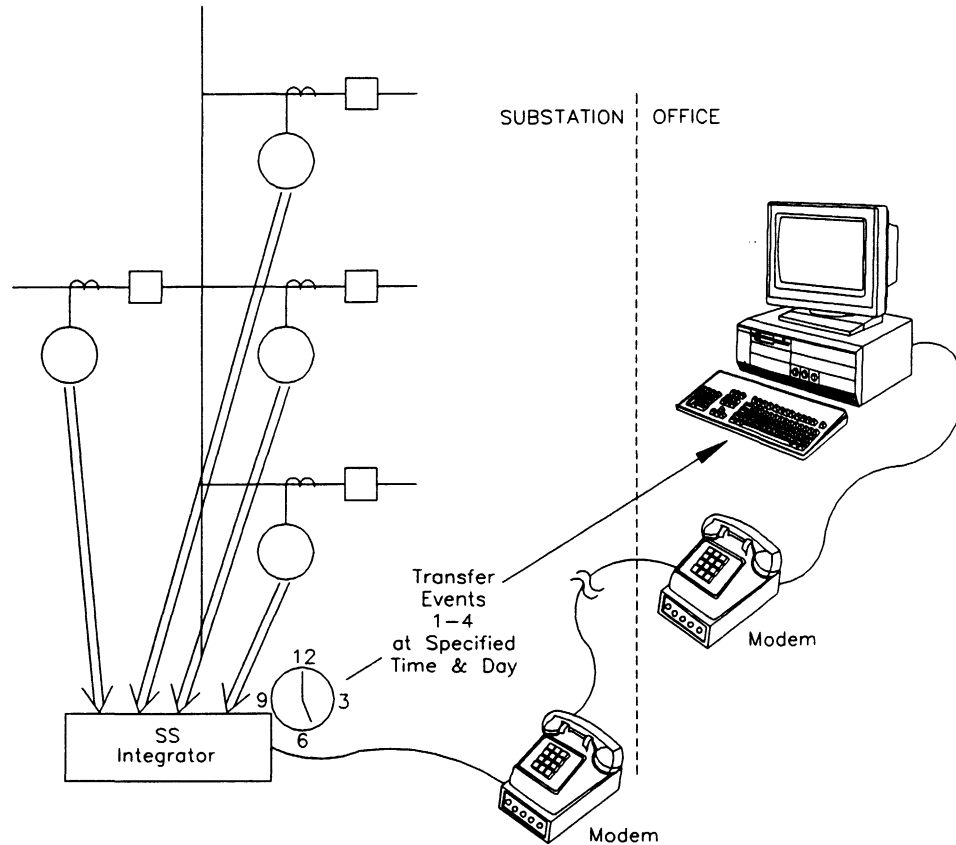

Figure 22: Send Event Report Data at a Specific Time Each or Any Day of the Week

Automatically Send Event Report Data After Each Event

For those who cannot wait to get the latest digital relay event report data from the most recent system disturbances, have the reports sent to your office after each event occurrence. The digital relay's automatic event summary triggers the automatic dial-out process to send the latest event report summary or full event report to a remote computer waiting to capture the event information.

Likewise, use the same trigger condition to send a phone number to your pager so you can call the substation from wherever you are to retrieve the event information.

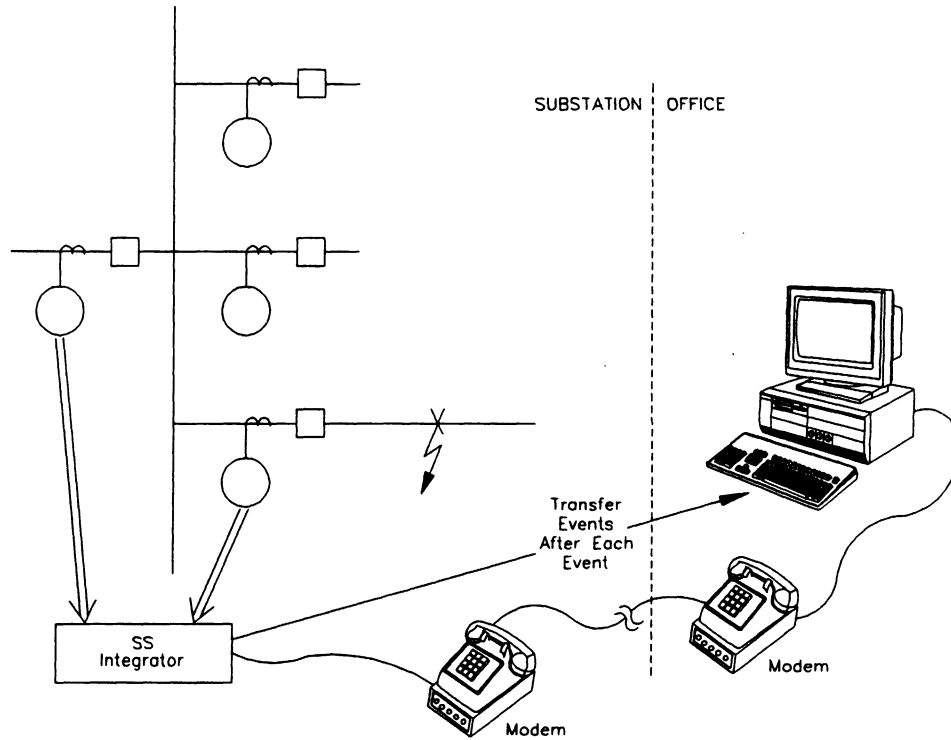

Figure 23: Automatically Send Event Report Data After Each Event

Concentrate and Filter Alarm Data

Concentrate alarm data from several relays and IEDs into a single alarm point for SCADA, but capture the individual alarm on a local substation annunciator or operator interface. Apply filtering to pass only permanent alarms to SCADA, but capture all intermittent alarms on the local substation log, or initiate a call directly to maintenance personnel for specific alarms.

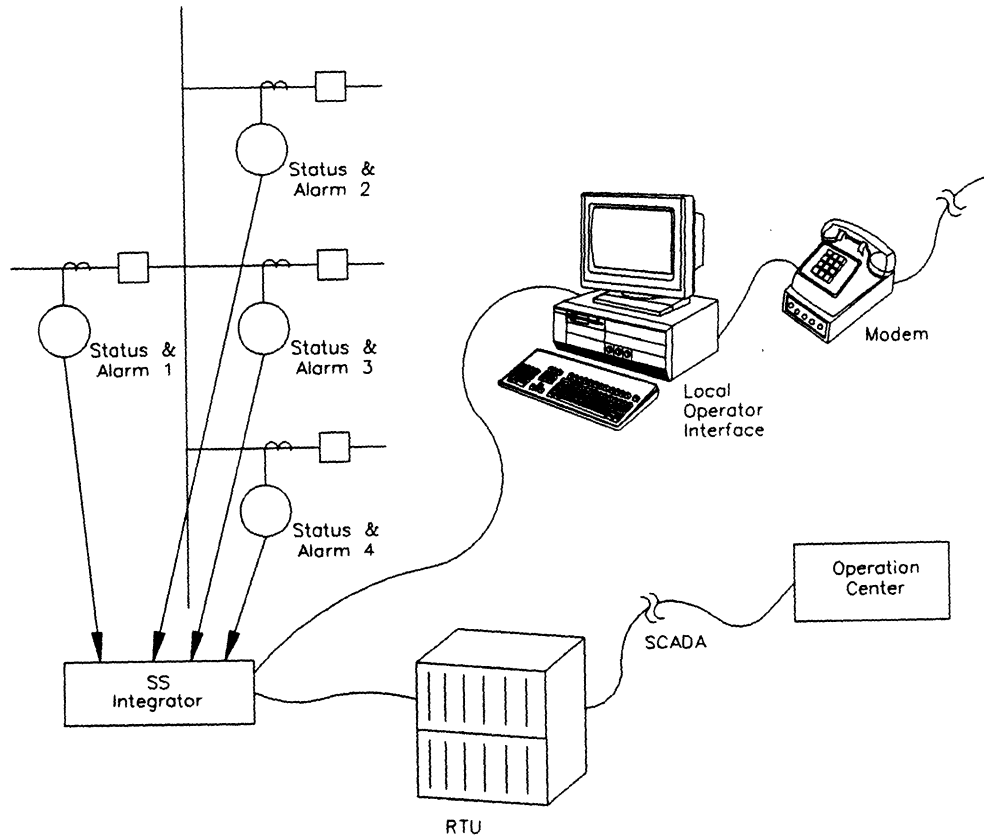

Figure 24: Concentrate and Filter Alarm Data

Automate Maintenance Functions

Several routine maintenance and data collection operations are easily performed by automated means with digital relays and substation integration techniques.

Automatically Check Pilot Scheme Communication

Pilot schemes, especially those using on-off type carrier, need to be checked periodically to determine that the communication equipment and channel are in good operating order. Some digital relays with programmable logic capability can be set to test the communication channel and alarm if there is a problem. Use substation integration techniques to periodically initiate this check process and pass the alarm message back to an operating or maintenance center when a problem is detected.

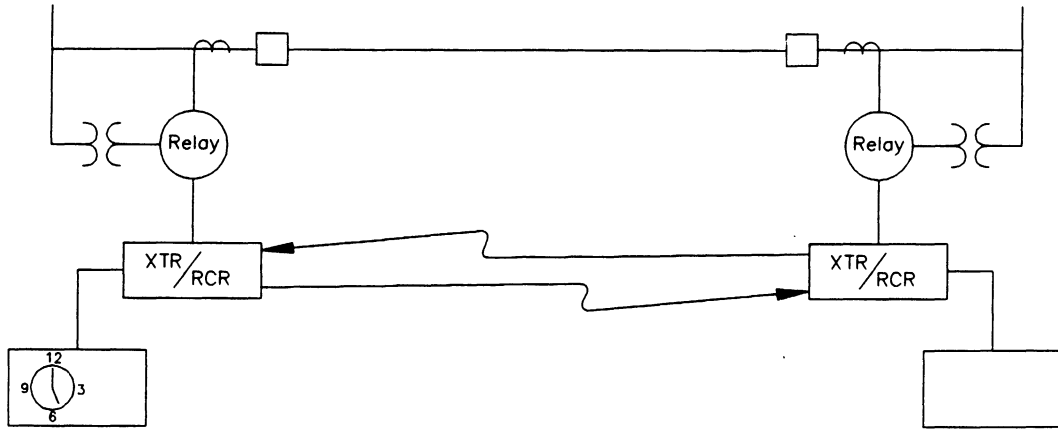

Figure 25: Automatically Check Pilot Scheme Communication

Accumulate Breaker Operation Data

Some digital relays collect breaker operation data, such as the number of operations and current interrupted for each operation. Many utilities are considering “just-in-time” breaker maintenance using breaker operation data to determine the need for breaker maintenance. However, breaker manufacturers are divided about the data that best indicates the need for breaker maintenance. Some say accumulated current, some say current squared, and some itemize the number of operations at several current ranges.

Collect the interrupted current for each operation and store it as a unique record to provide data for any of the breaker maintenance methods. Use substation integration techniques to download these data to a simple analysis program that calculates the need for breaker maintenance based on the manufacturer’s recommended method.

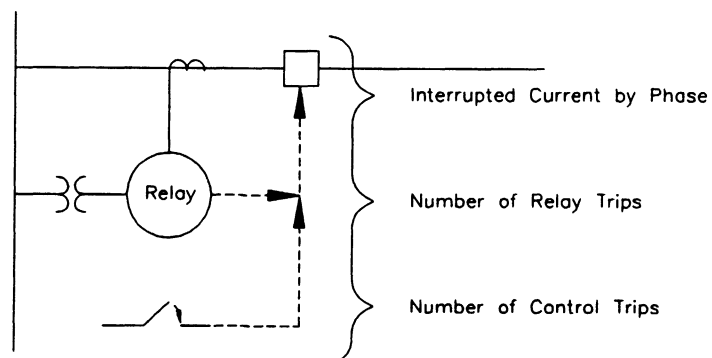

Figure 26: Capture Breaker Operation Data for Breaker Maintenance Personnel

Synchronize Device Clocks

Use substation integration techniques to synchronize device clocks in digital relays and other IEDs. Distribute time code to devices that accept IRIG-B and periodically send date and time commands to those devices that do not accept time code.

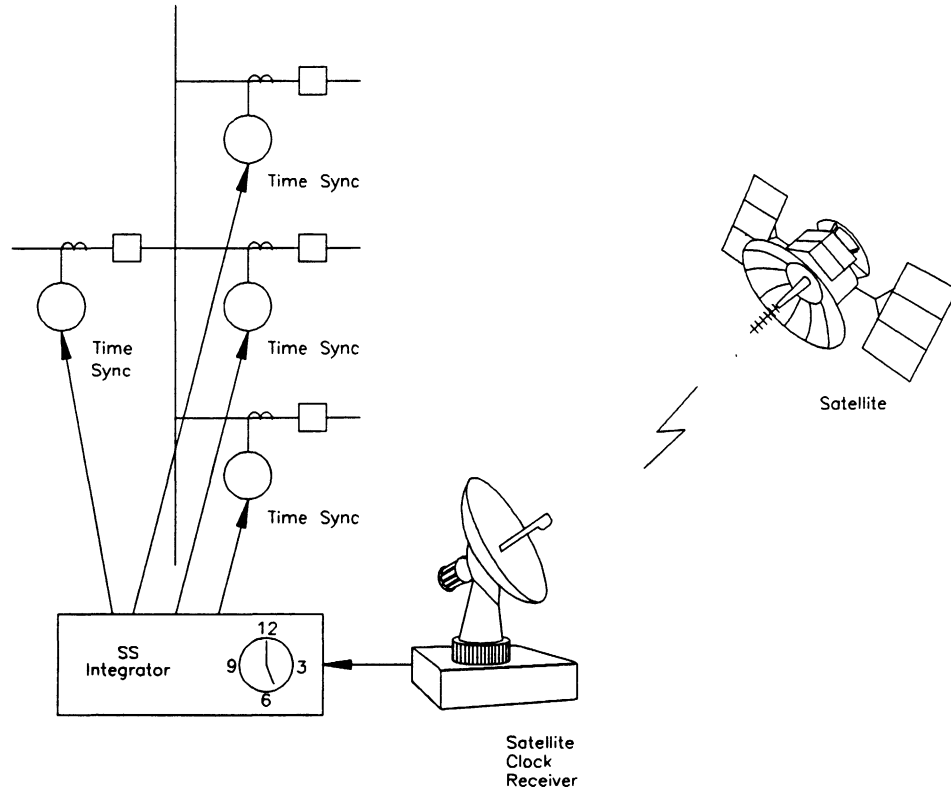

Figure 27: Synchronize Device Clocks

Send Relay Status Alarm Message to Relay Personnel

Filter relay status alarm messages from other equipment alarms, and either send the message to a maintenance office computer, or initiate a pager message using the dial-out process.

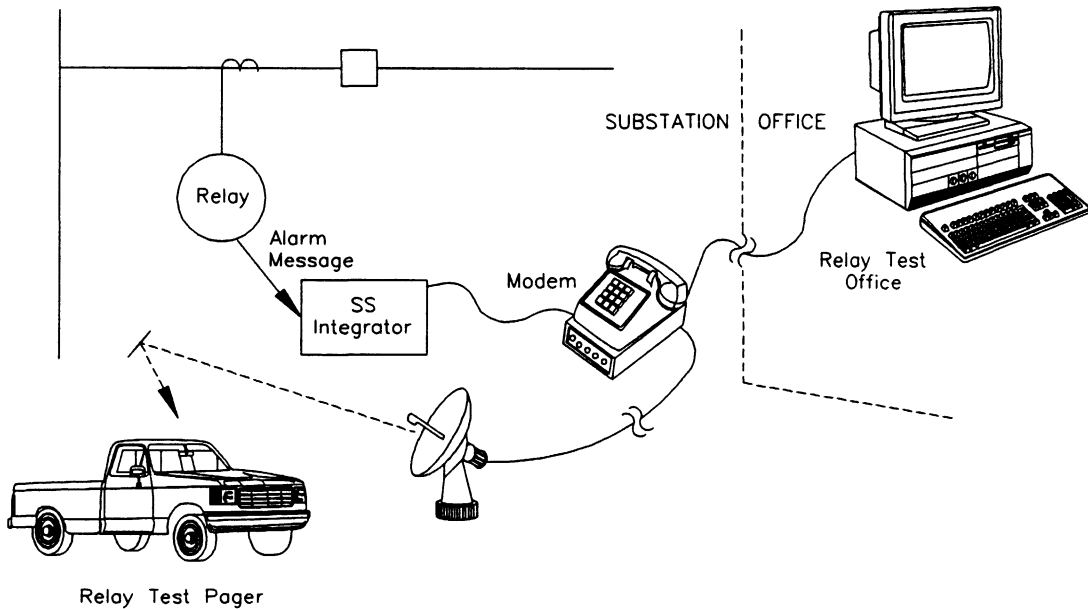

Figure 28: Send Relay Status Alarm Message to Relay Personnel

Improve Planning and Design Data

Most SCADA system's data retrieval is limited by communication or central database constraints. Transmission and subtransmission system data typically does not include per-phase currents and voltages, so system current and voltage unbalance cannot be measured. Many SCADA systems do not include distribution substations, so these utilities are forced to rely on manual meter reading for transformer and feeder load data. Millions of dollars are spent each year for system expansion and modification based on these data.

Utilities have found that there are tremendous economies in better managed distribution systems, but better system management requires more complete metering. Many of these utilities have also found that adding distribution substation data and collecting per-phase currents, voltages, watts, and VARs create expense and problems. The addition or expansion of substation RTUs, addition of transducers and RTU analog input points, and added wiring are a tremendous expense. The additional data creates a tremendous burden on the SCADA system that slows response time and overloads central processing and database capability. Operating personnel and planning personnel become adversaries in the attempt to control SCADA system design and operation.

Data integration at the substation level offers a solution that satisfies both concerns. The minimum real-time data essential for system operation are passed to the SCADA system; more complete real-time and historical data are archived in substation files for periodic bulk transfer. The archived data can be accessed on demand, retrieved, or automatically offloaded at a convenient time, locally to a floppy disk or PC, or via modem to a remote site.

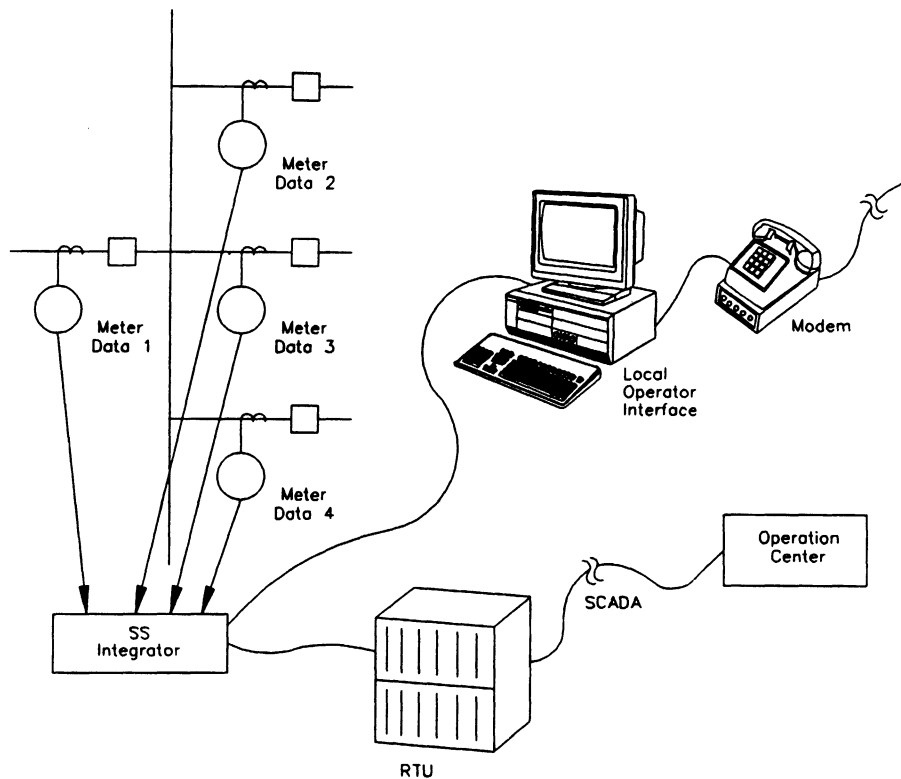

Figure 29: Concentrate, Integrate, and Filter Meter Data

The substation database is a prime candidate to include in a Wide Area Network communication system that can share data and provide access from virtually any communication point within the system.

Track System Currents, Voltages, Watts, and VARs

Complete data, including individual phase currents, voltages, watts, and VARs, and sequence currents and voltages are required to better understand the condition of a power system. A better understanding is the first step toward better management and efficient operation.

- **Monitor System Unbalance**

Use relay instantaneous phase, negative-sequence, and zero-sequence current and voltage quantities to monitor system unbalance.

Collect multiple data samples over time to monitor unbalance changes due to load and system changes. Check transmission system unbalance due to insufficient line transpositions. Adjust protection and control equipment settings to accommodate worst-case unbalance conditions, or use monitored quantities to adapt relay settings to system conditions.

- **Create Voltage and Load Profiles**

Collect instantaneous and integrated demand data to create load profiles for planning analysis. Chart substation voltage profile versus load to check voltage regulation settings and capacitor bank switching schedules.

- **Capture Substation Equipment Load, Voltage, and Thermal Profiles**

Time-tag integrated demand peak data, and chart high- and low-voltage excursions. Collect and correlate ambient and equipment temperature data from substation digital thermal devices.

Monitor and Improve Equipment Performance

Use substation data to monitor equipment operation and create data logs for reliability-based maintenance. Chart load tap changer positions and number of operations. Collect breaker and switch operation data.

- **Capacitor Banks**

Use individual phase, watt, and VAR data to check feeder capacitor banks for individual phase fuse or switch problems and monitor switching schedules.

- **Tap Changers and Voltage Regulators**

Use individual phase voltages to check tap changer or voltage regulator operation.

- **Breakers and Reclosers**

Use event report data to check breaker operating performance, including closing time, opening and current interrupting time, and restrike occurrence.

CONCLUSION

Substation relay data has many uses and offers considerable value to utility operating, maintenance, planning, engineering, and customer services personnel. New technology offers several alternatives to collect, store, and distribute this information in an efficient and economical manner.

Substation integration combines the data, control, and communication capabilities of modern digital relays and other IEDs to reduce substation cost and improve operating efficiency and system reliability. Substation integration can be incorporated in new substation design and established in existing substations through a retrofit process. The compact design of multifunction digital relay and communication equipment makes retrofit projects both feasible and economical.

Substation integration forms the foundation for future distribution automation system design and operation. The communication between digital relays and IEDs within the substation form a natural starting point for communication with IEDs on feeders and supply lines and at customer locations outside the substation.